

# Industrial Robotics Automation Catalog

## Product Datasheets



# Omron's 5 benefits

The new Omron Robotic Automation enhances the most demanding manufacturing lines providing **5 main benefits**

## Performance

Overall through-put is guaranteed by the synchronization of our Sysmac machine control with the new vision guided robots



## Quick Delivery

5 huge automated warehouses to provide parts in short time.

## Simple

Shortening the startup and maintenance time by the integrated software environment that controls the line.

## Efficient

All the production data coming from robots, controllers, sensors are collected, shared and managed to optimize the productivity.

## Flexible

Software assisted system generates automatically the new programming code.

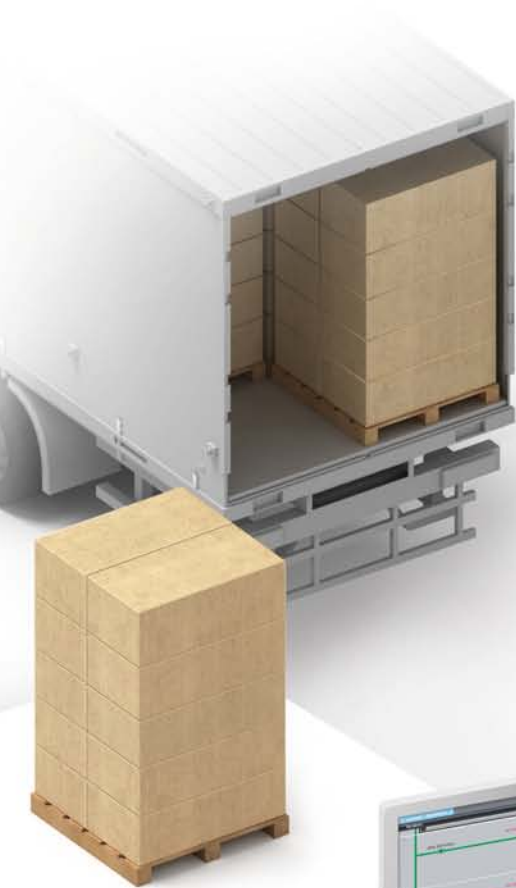

# Industrial robots - Three robot families with over 100+ models

## Manufacturing site innovation by using robots for various applications

Omron offers robotic automation solutions for applications from cutting-edge production facilities to manual operation processes by using our wide variety of control devices and integrating robotics into automation.

### Parallel robots

Hornet and Quattro are high-speed parallel robots ideal for use in food and beverage, pharmaceutical, and packaging industries. Quattro is a four axis robot with high payload capacity that excels in high speed precision.



Hornet 565  
Quattro 650/800



Articulated robots

Omron's 6-axis robot family is ideal for complex mechanical assemblies, material handling, inspection, and packaging.



Viper 650/850



Cobra 450/500/650  
eCobra 600/800

SCARA robots

The high-performance four-axis SCARA product family is ideal for precise mechanical assembly, material handling, packaging, and screw driving.

# Advanced Robotics Integrated Solution

The advanced robotics integrated solution is the world's first truly combined robotics and automation ecosystem designed to optimize the entire design and manufacturing cycle.

It provides a unified environment for Omron's strong robotics portfolio with the state of the art Omron NJ501-R machine controller and Sysmac Studio software.

## Benefits

### Control Integration

Simplify integration with unified control of robots and machines - traditionally performed by separate controllers - enabling intimate coordination between peripheral devices and robots to deliver automation systems that can achieve unprecedented levels of intricacy and dexterity.

### Integration of building process

Seamlessly integrate the entire process flow - throughout design, commissioning, operation and its maintenance - to resolve labor shortage in both production line development and implementation, reduce time to market.

## Components

### OMRON ROBOTS

Our line of integrated eCobra SCARA robots now come with real-time EtherCAT connectivity to an Omron NJ501-R.

### OMRON NJ501-R

Integrated machine and robotics controller that offers top performance and scalability, by seamlessly combining motion, robotics, logic, IO, and safety.

### SYSMAC Studio

Unified software platform to simulate, deploy, control, and monitor robotics alongside the Omron automation ecosystem.

### Application Manager

Application-level runtime environment for vision, recipe management and robot application modules like PackManager.



SCARA EtherCAT slave robot



Machine Automation Controller and robot EtherCAT master



Sysmac Studio software to simulate and program applications

# Standalone Robotics

Our full portfolio of high performing, reliable, and industry-proven robots can optimally address the most demanding robotics applications.

By programing our robots with the simple and easy to use software, robot applications can be developed effortlessly and commissioned fast.

## Benefits

### Top Value

High performing robotics and flexible platform to integrate diverse robotics applications in auto, digital, pharma, and F&B industries.

### Ease of Integration

Simplify integration with a powerful yet easy-to-use development environment for robotics, vision, feeding, and packaging applications.

### Reliability

Long-lasting and proven hardware and software with thousands of robots deployed worldwide, backed-up by Omron's industry leading support network.

## Components

### OMRON Robotics

Our full line of SCARA, parallel, and articulated robots support traditional standalone deployments as well as connectivity to controllers.

### Automated Control Environment (ACE)

PC-based development software to easily program Omron's portfolio of robots, vision and feeding systems.

### Application Manager

Application-level runtime environment for vision, recipe management and robot application modules like PackManager.

### ePLC

Software option to enable robot communication with Omron NX/NJ/NY or third party PLCs via Ethernet.



Full suite of robots with Ethernet connectivity

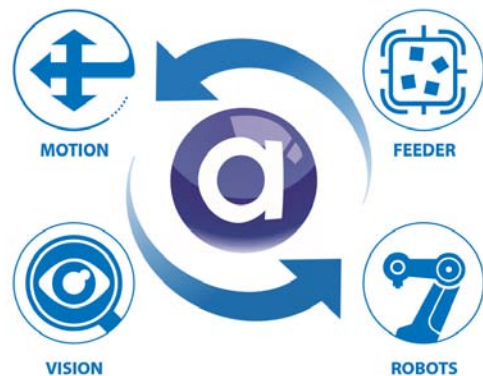

ACE software for application development

# Robot Use Cases

Parallel Robot



**Recommended Process & Application**

		Hornet 565	Quattro 650/800
Food & Beverage	Primary Packing		◆
	Secondary Packing	◆	◆
	Aligning Packing	◆	◆
	Shipping and receiving (palletizing)		
Digital	Tightening units		
	General assembling		
	Deburring and polishing		
	Sealing		
	Measuring, inspection, testing		◆
Automotive	Resin molding		
	Press operation handling		
	Machine loading		
	Sealing		
	Measuring, inspection, testing		
	Material handling		
SPECS	Mounting		Inverted
	Payload capacity	3 kg (8 kg *1)	650: 6 kg (15 kg *2) 800: 4 kg ( kg *2)
	Radius	565 mm	650 to 800 mm
	Reach	---	---
	Position repeatability	±0.10 mm	±0.10 mm

\*1. Without rotation axis  
\*2. Quattro using P30



SCARA Robot

Articulated Robot



Cobra  
450/500/650

eCobra  
600/800

Viper  
650/850/Inverted

	◆	
	◆	◆
	◆	◆
◆	◆	◆
◆	◆	◆
◆	◆	◆
◆	◆	◆
◆	◆	◆
		◆
◆	◆	◆
◆	◆	◆
◆	◆	◆
◆	◆	◆
		◆
	Table / Floor	Table / Floor / Inverted
5 kg	5.5 kg	5 kg
---	---	---
450 to 650 mm	600 to 800 mm	653 to 855 mm
±0.02 mm	±0.017 mm	±0.02 to 0.03 mm

# Advanced Robotics Integrated Solution



iX3



iX4



Viper 650/850



eCobra 600/800

# Parallel Robots iX3-565

EtherCAT (NJ501-R) version

## Parallel robot ideal for use in the food and beverage, pharmaceutical, and healthcare industries

- EtherCAT connectivity to the Omron NJ501-R controller and programming through the familiar IEC 61131-3 programming language or scripting (eV+).
- Tracks up to a conveyor speed of 1.4 m/s
- Designed with a high payload to support multi-hand (multi-picking)
- Supports fast Pick & Place on a fast conveyor
- Helps reduce mounting cost and robot vibration
- Maximum working diameter 1,130 mm
- Working height 425 mm
- Maximum payload 8 kg
- Weight 52 kg



## Specifications

Product name		iX3				
Size		565				
Number of axes		3 Axis		4 Axis		
IP		Standard	IP65/67	Standard	IP65/67	
Part Number		RX3-2065600	RX3-2065610	RX3-2065604	RX3-2065614	
Mounting		inverted				
Working volume	X,Y axis (stroke)	1130 mm				
	Z axis (stroke)	425 mm				
	theta axis (rotation angle)	-		±360°		
Maximum Payload		8 kg		3 kg		
Repeatability		±0.10 mm				
Cycle times, sustained, 20°C ambient *1	Payload 0.1 kg	0.32 s		0.35 s		
	Payload 1.0 kg	0.34 s		0.37 s		
	Payload 3.0 kg	0.38 s		0.42 s		
Power Requirements		24 VDC: 6 A 200 to 240 VAC: 10 A, single-phase				
Protection	Base	Topside of robot	IP20	IP65	IP20	IP65
		Underside of robot	IP65			
	Platform, Arms		IP67			
Environment Requirements	Ambient Temperature		1 to 40°C			
	Humidity Range		5 to 90% (non-condensing)			
Weight		52 kg				
Basic configuration	Controller		iCS-ECAT			
	On-board I/O (Input/Output)		12/8			
	Conveyor tracking input		2			
	RS-232C serial communications port		1			
	Programming environment		Sysmac Studio 64-bit			
	ACE Sight		Yes			
	ePLC Connect		No			
ePLC I/O		No				
Connectable controller		NJ501-R Series				

\*1. Adept cycle, in mm (25/305/25)

# Dimensions

(Unit: mm)

## iX3

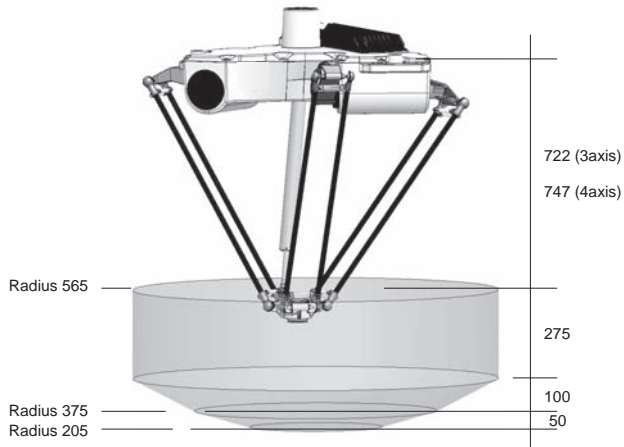

## Flange

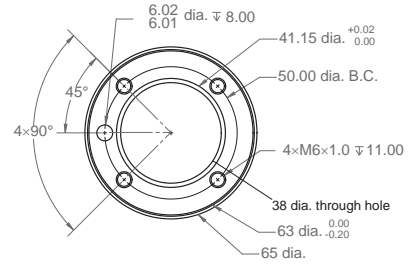

## Footprint

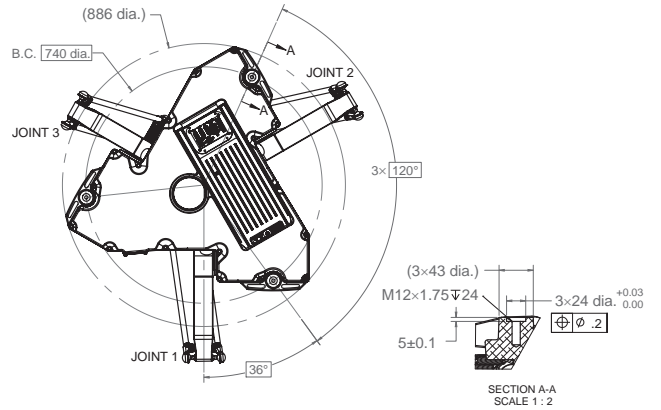

## Front panel



# Robot Parts Code and Bundled Accessories

Type	iX3	
IP	Standard	IP65/67
iX3 3 Axis	RX3-2065600	RX3-2065610
iX3 4 Axis	RX3-2065604	RX3-2065614
Overview	To be used in conjunction with NJ501-R Series controller, which can connect up to 8 robots via EtherCAT	
Bundled Accessories	<ul style="list-style-type: none"> <li>XSYSTEM cable with jumpers and Ethernet Management port, 1.8 m/6 ft (13323-100)</li> <li>Front panel kit (92546-10358)</li> </ul>	

## Four-axis parallel robot achieves high speed and high precision

- EtherCAT connectivity to the Omron NJ501-R controller and programming through the familiar IEC 61131-3 programming language or scripting (eV+).
- Four-axis arm evenly distributes the load on the robot
- Fast and high-precision conveyance and assembly
- Designed with a high payload to support multi-hand (multi-picking)
- Supports fast Pick & Place on a fast conveyor
- Meets the sanitary standards of the United States Department of Agriculture for prevention of product contamination
- Maximum working diameter 1,300 mm
- Working height 500 mm
- Maximum payload 15 kg
- Weight 117 kg

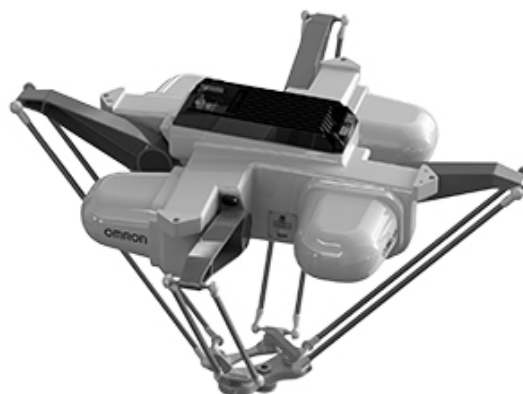

## Specifications

Product name		iX4			
Size		650			
Type		H		HS	
IP		Standard	IP65/67	Standard	
Part Number		RX4-216600[]	RX4-216602[]	RX4-216601[]	
Number of axes		4			
Mounting		inverted			
Working volume	X,Y axis (stroke)	1300 mm			
	Z axis (stroke)	500 mm			
	theta axis (rotation angle)	0° (fixed) (P30)			
		±46.25° (P31)			
±92.5° (P32)					
Maximum Payload		6 kg (P30: 15 kg)		3 kg (P30: 12 kg)	
Repeatability		±0.10 mm			
Cycle times, sustained, at 20°C ambient	Payload 0.1 kg	0.30 s *1, 0.46 s *2		0.39 s *1, 0.55 s *2	
	Payload 1.0 kg	0.36 s *1, 0.47 s *2		0.41 s *1, 0.58 s *2	
	Payload 2.0 kg	0.37 s *1, 0.52 s *2		0.42 s *1, 0.59 s *2	
	Payload 4.0 kg	0.41 s *1, 0.58 s *2		-	
	Payload 6.0 kg	0.43 s *1, 0.61 s *2		-	
Power Requirements		24 VDC: 6 A 200 to 240 VAC: 10 A, single-phase			
Protection	Base	Topside of robot	IP20	IP65	IP66
		Underside of robot	IP65	IP65	IP66
	Platform, Arms	IP67			
Environment Requirements	Ambient Temperature	1 to 40°C			
	Humidity Range	5 to 90% (non-condensing)			
Weight		117 kg			
USDA-Accepted for meat and poultry processing		---	---	Yes	
Basic configuration	Controller	iCS-ECAT			
	On-board I/O (Input/Output)	12/8			
	Conveyor tracking input	4			
	RS-232C serial communications port	1			
	Programming environment	Sysmac Studio 64-bit			
	ACE Sight	Yes			
	ePLC Connect	No			
Connectable controller		Omron NJ501-R Series			

\*1. Adept cycle, in mm (25/305/25)

\*2. Extended cycle, in mm (25/700/25)

# Dimensions

(Unit: mm)



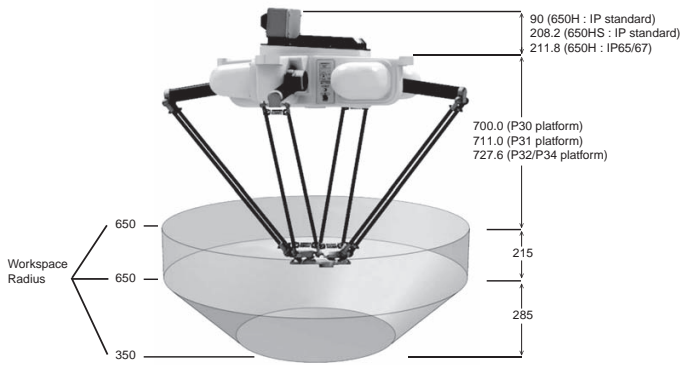

## iX4-650H/HS

Note: The figure shows the HS type.

### Front panel



Four choices of platform offer different ranges of rotation.

Appearance				
Type	P30	P31	P32	P34
Rotation angle	No rotation	$\pm 46.25^\circ$	$\pm 92.5^\circ$	$\pm 185^\circ$
Maximum Payload	H: 15 kg, HS: 12 kg	H: 6 kg, HS: 3 kg	H: 6 kg, HS: 3 kg	H: 6 kg, HS: 3 kg

Note: The platform appearances of the H type are shown above. The platform of the HS type is made of stainless steel.

## Robot Parts Code and Bundled Accessories

Type	iX4			
	IP	Standard (H)	Standard (HS)	IP65/67
iX4 P30		RX4-2166000	RX4-2166010	RX4-2166020
iX4 P31		RX4-2166001	RX4-2166011	RX4-2166021
iX4 P32		RX4-2166002	RX4-2166012	RX4-2166022
iX4 P34		RX4-2166004	RX4-2166014	RX4-2166024
Overview	To be used in conjunction with NJ501-R Series controller, which can connect up to 8 robots via EtherCAT			
Bundled Accessories	<ul style="list-style-type: none"> <li>XSYSTEM cable with jumpers and Ethernet Management port, 1.8 m/6 ft (13323-100)</li> <li>Front panel kit (92546-10358)</li> </ul>			

## Four-axis parallel robot achieves high speed and high precision

- EtherCAT connectivity to the Omron NJ501-R controller and programming through the familiar IEC 61131-3 programming language or scripting (eV+).
- Four-axis arm evenly distributes the load on the robot
- Fast and high-precision conveyance and assembly
- Designed with a high payload to support multi-hand (multi-picking)
- Supports fast Pick & Place on a fast conveyor
- Meets the sanitary standards of the United States Department of Agriculture for prevention of product contamination
- Maximum working diameter 1,600 mm
- Working height 500 mm
- Maximum payload 10 kg
- Weight 117 kg



## Specifications

Product name		iX4			
Size		800			
Type		H		HS	
IP		Standard	IP65/67	Standard	
Part Number		RX4-216630[]	RX4-216632[]	RX4-216631[]	
Number of axes		4			
Mounting		inverted			
Working volume	X,Y axis (stroke)	1600 mm			
	Z axis (stroke)	500 mm			
	theta axis (rotation angle)	0° (fixed) (P30)			
		±46.25° (P31)			
±92.5° (P32)					
Maximum Payload		4 kg (P30:10 kg)	1 kg (P30: 7 kg)		
Repeatability		±0.10 mm			
Cycle times, sustained (at 20°C ambient)	Payload 0.1 kg	0.33 s *1, 0.48 s *2		-	
	Payload 1.0 kg	0.38 s *1, 0.50 s *2		0.45 s *1, 0.62 s *2	
	Payload 2.0 kg	0.40 s *1, 0.55 s *2		-	
	Payload 4.0 kg	0.45 s *1, 0.62 s *2		-	
Power Requirements		24 VDC: 6 A 200 to 240 VAC: 10 A, single-phase			
Protection	Base	Topside of robot	IP20	IP65	IP66
		Underside of robot	IP65	IP65	IP66
	Platform, Arms		IP67		
Environment Requirements	Ambient Temperature		1 to 40°C		
	Humidity Range		5 to 90% (non-condensing)		
USDA-Accepted for meat and poultry processing		---	---	Yes	
Weight		117 kg			
Basic configuration	Controller		iCS-ECAT		
	On-board I/O (Input/Output)		12/8		
	Conveyor tracking input		4		
	RS-232C serial communications port		1		
	Programming environment		Sysmac Studio 64-bit		
	ACE Sight		Yes		
	ePLC Connect		No		
ePLC I/O		No			
Connectable controller		Omron NJ501-R Series			

\*1. Adept cycle, in mm (25/305/25)

\*2. Extended cycle, in mm (25/700/25)



# Dimensions

(Unit: mm)



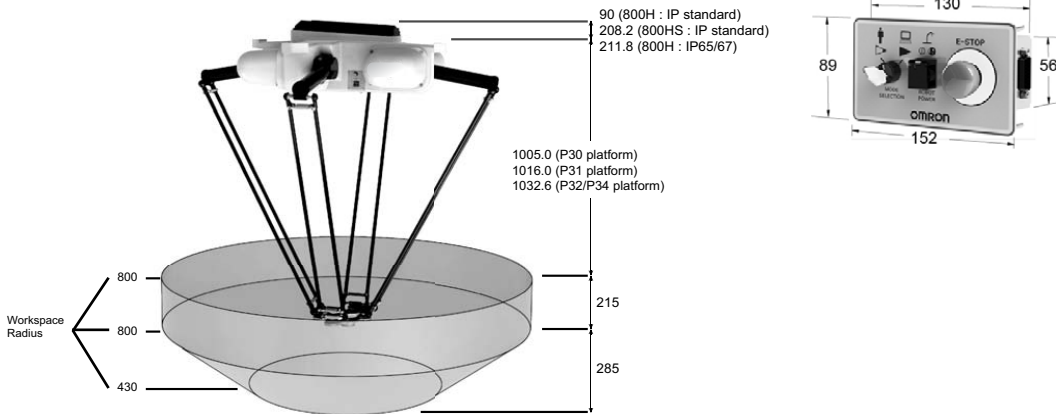

## iX4-800H/HS

Note: The figure shows the H type.

### Front panel



Four choices of platform offer different ranges of rotation.

Appearance				
Type	P30	P31	P32	P34
Rotation angle	No rotation	$\pm 46.25^\circ$	$\pm 92.5^\circ$	$\pm 185^\circ$
Maximum Payload	H: 10 kg, HS: 7 kg	H: 4 kg, HS: 1 kg	H: 4 kg, HS: 1 kg	H: 4 kg, HS: 1 kg

Note: The platform appearances of the H type are shown above. The platform of the HS type is made of stainless steel.

## Robot Parts Code and Bundled Accessories

Type	ix4		
	Standard (H)	Standard (HS)	IP65/67
iX4 P30	RX4-2166300	RX4-2166310	RX4-2166320
iX4 P31	RX4-2166301	RX4-2166311	RX4-2166321
iX4 P32	RX4-2166302	RX4-2166312	RX4-2166322
iX4 P34	RX4-2166304	RX4-2166314	RX4-2166324
Overview	To be used in conjunction with NJ501-R Series controller, which can connect up to 8 robots via EtherCAT		
Bundled Accessories	<ul style="list-style-type: none"> <li>XSYSTEM cable with jumpers and Ethernet Management port, 1.8 m/6 ft (13323-100)</li> <li>Front panel kit (92546-10358)</li> </ul>		

# i4-650H/750H/850H EtherCAT (NJ501-R) version

## New i4H robot for precision machining, assembly, and material handling

- EtherCAT connectivity to the Omron NJ501-R controller and programming through the familiar IEC 61131-3 programming language or scripting (eV+).
- Simple integration with EtherCAT controller integrated into the robot base.
- Easy to service with high visibility, multi-colored light ring and display to show the robot status
- Reach Options: 650 mm, 750 mm, 850 mm
- Weight 650: 50.4 kg ; 750: 50.9 kg ; 850: 51.6 kg



## Specifications

Product		i4-650H		i4-750H		i4-850H	
Type		Standard		Standard		Standard	
Quill Length (mm)		210 mm	410 mm	210 mm	410 mm	210 mm	410 mm
Part Number		RS4-2066502	RS4-2066504	RS4-2067502	RS4-2067504	RS4-2068502	RS4-2068504
Number of axes		4					
Mounting		Table					
Reach (mm)		650		750		850	
Maximum Payload (kg)		15					
Repeatability	XY (mm)	±0.015					
	Z (mm)	±0.01					
	Theta (deg)	±0.005					
Joint Range	Joint 1 (deg)	±152					
	Joint 2 (deg)	±140					
	Joint 3 (mm)	210 mm (Standard Quill), 410 mm (Long Quill)					
	Joint 4 (deg)	±360					
Inertia Moment (Max.)	Joint 4 (kg m <sup>2</sup> )	0.5					
Maximum push force - vertical	Joint 3 (N)	588, 3 s on, 2 s off					
Joint Speeds	Joint 1 (deg/s)	450					
	Joint 2 (deg/s)	720					
	Joint 3 (mm/s)	1583					
	Joint 4 (deg/s)	2400					
Cycle times *1	Burst (s)	0.41		0.39		0.39	
	Sustained (s)	0.45		0.46		0.50	
	Blended Burst (s) *2	0.32		0.31		0.31	
Power Requirements		24 VDC: 8 A (max) 200 to 240 VAC: 12.0 A (max)					
Protection		IP20 / NEMA Type 1					
Environment Requirements	Ambient Temperature	5 to 40°C					
	Humidity Range	5 to 90% non-condensing					
Weight (kg)		50.4		50.9		51.6	
Basic Configuration	Controller	iCS-ECAT					
	On-board I/O	12 inputs / 8 outputs					
	End of Arm EtherCAT Connection	1					
	Pneumatic connections	4x 6 mm pneumatic connectors					
	Conveyor tracking input	2					
	RS-232C serial comm port	1					
	Programming	Sysmac Studio 64-bit					
	Vision Manager	Yes					
Pack Manager	Yes						
Connectable Controller		Omron NJ501-R Series					

\*1. Adept cycle, in mm 25/305/25 (seconds, at 20°C ambient) with 2.0 kg payload

\*2. Fast cycle, in mm (25/305/25) (seconds, at 20°C ambient) with 2.0 kg payload but with arc motion

# Dimensions

(Unit: mm)

## i4 650 H Dimensions

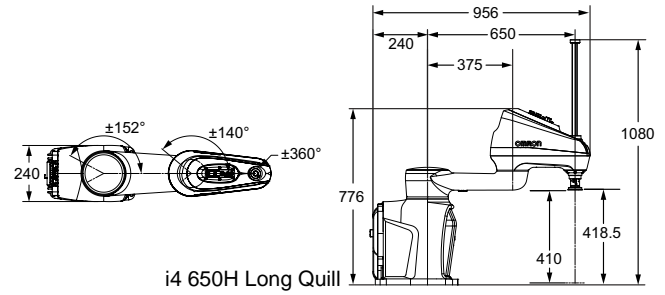
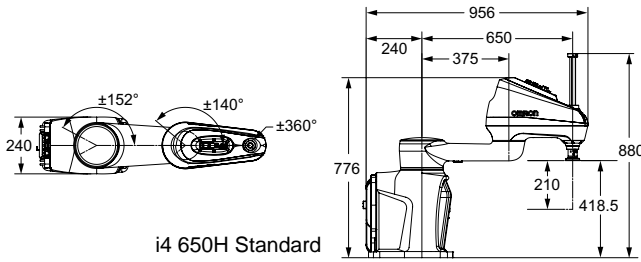

## i4 750H Dimensions

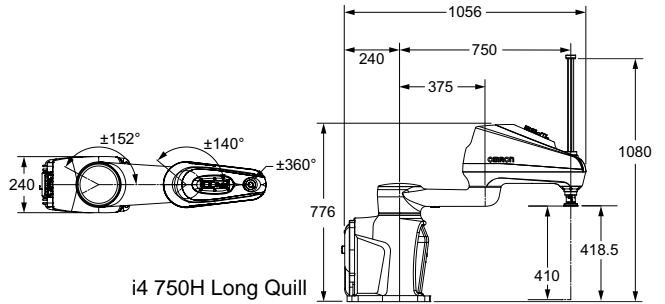
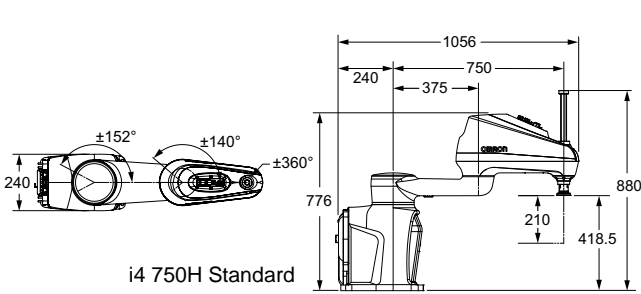

## i4 850H Dimensions

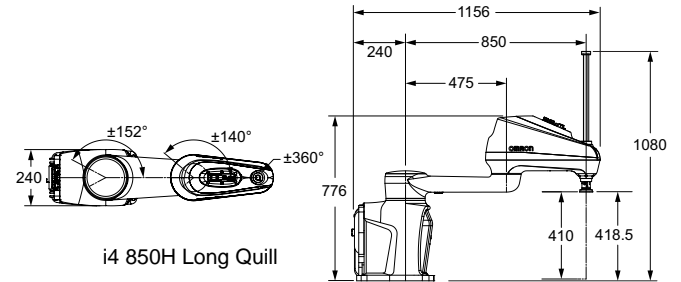
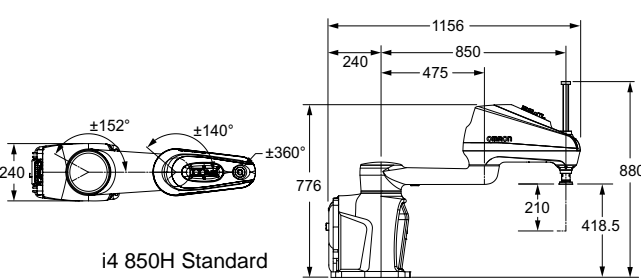

## Front Panel



## Tool Flange

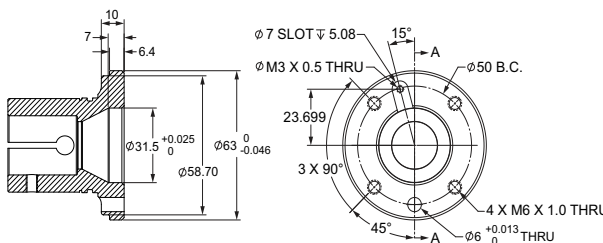

## Mounting Flange

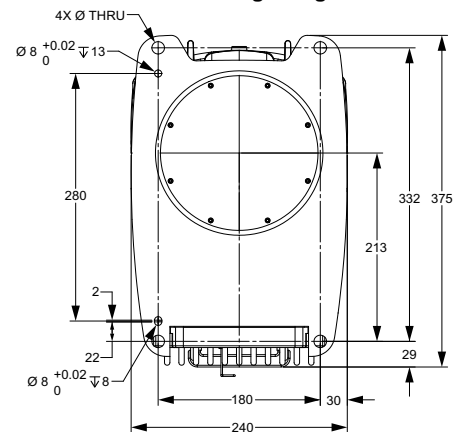

## Robot Parts Code and Bundled Accessories

Product	i4-650H		i4-750H		i4-850H	
Type	Standard		Standard		Standard	
Quill Length	210 mm	410 mm	210 mm	410 mm	210 mm	410 mm
Overview	SCARA Robot Arm + Integrated iCS ECAT Controller					
Bundled Accessories	XSYSTEM cable with jumpers, and Ethernet Management port, 1.8 m/6 ft (13323-100) Front Panel Kit (92546-10358)					
Optional Accessories	Plate, eCobra Adapter (Allows i4H to be mounting with eCobra mount hole pattern) (21636-000) Camera Bracket Mount (18908-000)					

# i4-650H/750H/850H Inverted

EtherCAT (NJ501-R) version

## New i4H robot for precision machining, assembly, and material handling

- EtherCAT connectivity to the Omron NJ501-R controller and programming through the familiar IEC 61131-3 programming language or scripting (eV+).
- Easy to service with high visibility, multi-colored light ring and display to show the robot status
- Reach Options: 650 mm, 750 mm, 850 mm
- Weight 650: 50.4 kg ; 750: 50.9 kg ; 850: 51.6 kg



## Specifications

Product		i4-650H		i4-750H		i4-850H	
Type		Inverted		Inverted		Inverted	
Quill Length (mm)		210 mm	410 mm	210 mm	410 mm	210 mm	410 mm
Part Number		RS4-2066702	RS4-2066704	RS4-2067702	RS4-2067704	RS4-2068702	RS4-2068704
Number of axes		4					
Mounting		Ceiling					
Reach (mm)		650		750		850	
Maximum Payload (kg)		15					
Repeatability	XY (mm)	±0.015					
	Z (mm)	±0.01					
	Theta (deg)	±0.005					
Joint Range	Joint 1 (deg)	±152					
	Joint 2 (deg)	±140					
	Joint 3 (mm)	210 mm (Standard Quill), 410 mm (Long Quill)					
	Joint 4 (deg)	±360					
Inertia Moment (Max.)	Joint 4 (kg m <sup>2</sup> )		0.5				
Maximum push force - vertical	Joint 3 (N)		588, 3 s on, 2 s off				
	Joint 1 (deg/s)		450				
Joint Speeds	Joint 2 (deg/s)		720				
	Joint 3 (mm/s)		1583				
	Joint 4 (deg/s)		2400				
Cycle times *1	Burst (s)		0.41	0.39	0.39		
	Sustained (s)		0.45	0.46	0.50		
	Blended Burst (s) *2		0.32	0.31	0.31		
Power Requirements		24 VDC: 8 A (max) 200 to 240 VAC: 12 A (max)					
Protection		IP20 / NEMA Type 1					
Environment Requirements	Ambient Temperature		5 to 40°C				
	Humidity Range		5 to 90% non-condensing				
Weight (kg)		50.4	50.9	51.6			
Basic Configuration	Controller		iCS-ECAT				
	On-board I/O		12 inputs / 8 outputs				
	End of Arm EtherCAT Connection		1				
	Pneumatic pass-through connections		4x 6 mm pneumatic connectors				
	Conveyor tracking input		2				
	RS-232C serial comm port		1				
	Programming Environment		Sysmac Studio 64-bit				
Vision Manager		Yes					
Pack Manager		Yes					
Connectable Controller		Omron NJ501-R Series					

\*1. Adept cycle, in mm 25/305/25 (seconds, at 20°C ambient) with 2.0 kg payload

\*2. Fast cycle, in mm (25/305/25) (seconds, at 20°C ambient) with 2.0 kg payload but with arc motion

# Dimensions

(Unit: mm)

## i4 650 H Dimensions

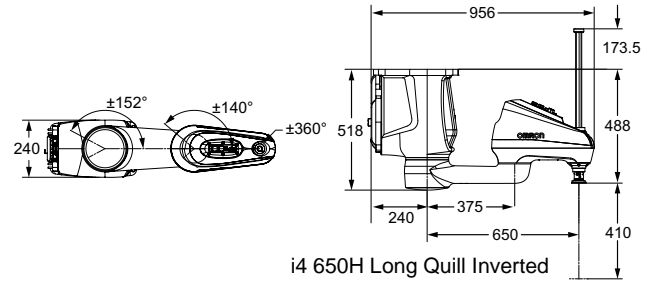
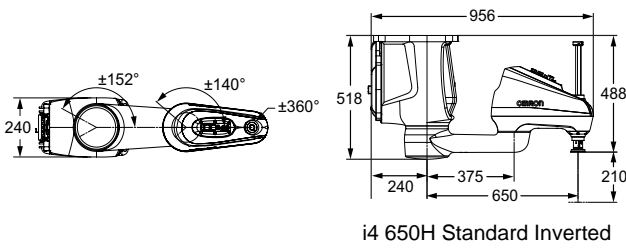

## i4 750H Dimensions

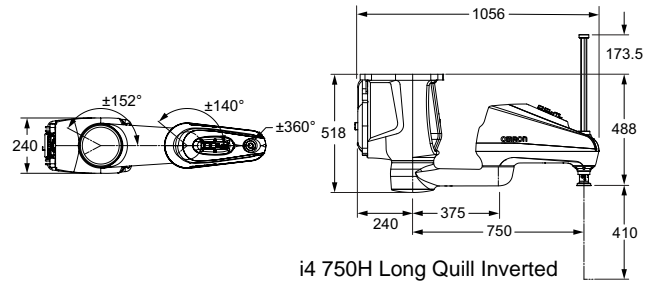
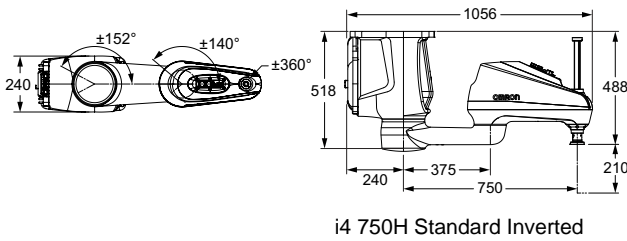

## i4 850H Dimensions

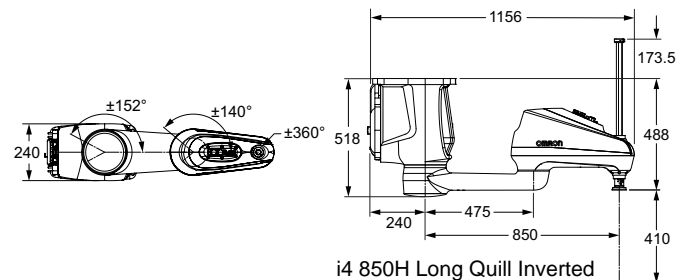
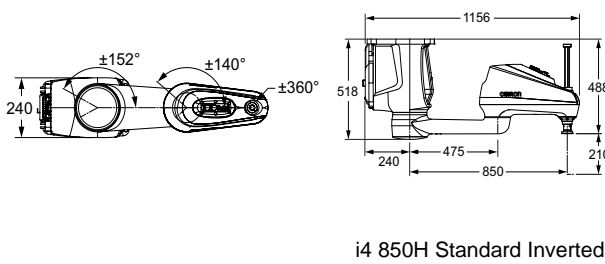

## Front Panel



## Tool Flange

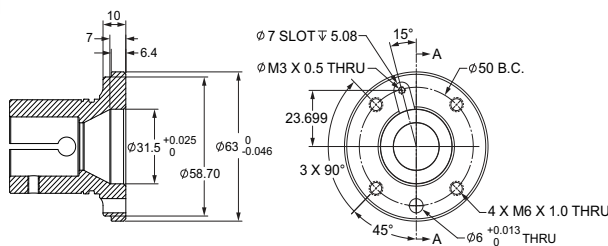

## Mounting Flange

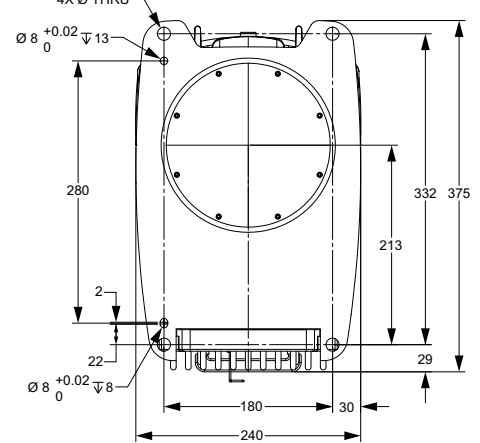

# Robot Parts Code and Bundled Accessories

Product	i4-650H		i4-750H		i4-850H	
Type	Inverted		Inverted		Inverted	
Quill Length	210 mm	410 mm	210 mm	410 mm	210 mm	410 mm
Interface Panel Orientation	Rear Panel	Bottom Panel	Rear Panel	Bottom Panel	Rear Panel	Bottom Panel
Part Number	RS4-2066702	RS4-2066704	RS4-2067702	RS4-2067704	RS4-2068702	RS4-2068704
Overview	SCARA Robot Arm + Integrated iCS ECAT Controller					
Bundled Accessories	XSYSTEM cable with jumpers, and Ethernet Management port, 1.8 m/6 ft (13323-100) Front Panel Kit (92546-10358)					
Optional Accessories	Plate, eCobra Adapter (Allows i4H to be mounting with eCobra mount hole pattern) (21636-000) Camera Bracket Mount (18908-000)					

## Mid-size SCARA robot for precision machining, assembly, and material handling

- EtherCAT connectivity to the Omron NJ501-R controller and programming through the familiar IEC 61131-3 programming language or scripting (eV+)
- High repeatability suitable for material handling and precision assembly
- High payload for screw-driving tools
- Amplifier and controller built into the robot simplifies integration
- Choose the right robot for you application from two different types
- Reach 600 mm
- Maximum payload 5.5 kg
- Weight 41 kg



## Specifications

Product name		eCobra			
		600 Standard		600 Pro	
		Standard	Cleanroom	Standard	Cleanroom
Part Number		RL4-1166000	RL4-1166010	RL4-2166000	RL4-2166010
Number of axes		4			
Mounting		table/floor			
Reach		600 mm			
Maximum Payload		5.5 kg			
Repeatability	XY	±0.017 mm			
	Z	±0.003 mm			
	Theta	±0.019°			
Joint Range	Joint 1	±105°			
	Joint 2	±157.5°			
	Joint 3	210 mm			
	Joint 4	±360°			
Inertia Moment (Max.)	Joint 4	450 kg-cm <sup>2</sup>			
Joint Speeds	Joint 1	386°/s			
	Joint 2	720°/s			
	Joint 3	1100 mm/s			
	Joint 4	1200°/s			
Power Requirements		24 VDC: 6 A 200 to 240 VAC: 10 A, single-phase			
Protection		IP20			
Clean Class		---	Class 10	---	Class 10
Environment Requirements	Ambient Temperature	5 to 40°C			
	Humidity Range	5 to 90% (non-condensing)			
Weight		41 kg			
Basic configuration	Controller	iCS-ECAT			
	On-board I/O (Input/Output)	12/8, 4 Solenoid Output			
	Conveyor tracking input	No			2
	RS-232C serial communications port	1			
	Programming environment	Sysmac Studio 64-bit			
	ACE Sight	Yes			
	ePLC Connect	No			
ePLC I/O	No			No	
Connectable controller		Omron NJ501-R Series			

# Dimensions

(Unit: mm)

## eCobra 600

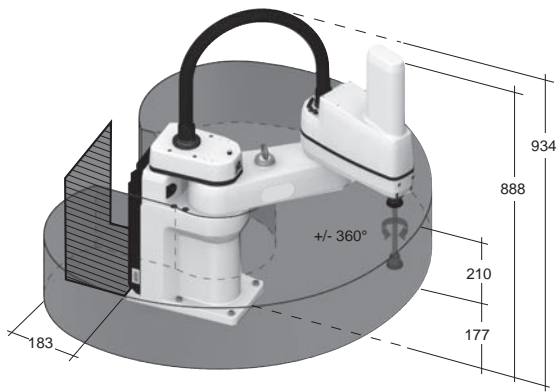

- Work Envelope: Radius 600 mm  
Inner Limit: Radius 163 mm  
Height: 210 mm
- ▨ Required clearance to open eAIB Chassis

### Flange

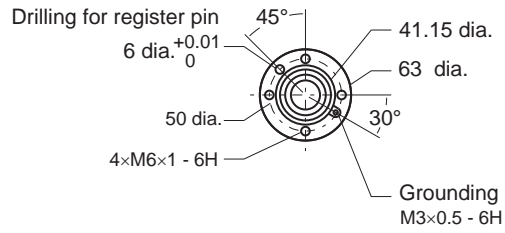

### Footprint

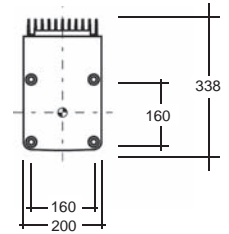

### Front panel



## Robot Parts Code and Bundled Accessories

Type	eCobra	
	Standard	Cleanroom
<b>Cleanroom</b>		
<b>eCobra 600 Standard</b>	RL4-1166000	RL4-1166010
<b>eCobra 600 Pro</b>	RL4-2166000	RL4-2166010
<b>Overview</b>	Robot + iCS-ECAT	
<b>Purpose</b>	To be used in conjunction with NJ501-R controller, which can connect up to 8 robots via EtherCAT	
<b>Bundled Accessories</b>	<ul style="list-style-type: none"> <li>• XSYSTEM cable with jumpers, and Ethernet Management port, 1,8 m/6 ft (13323-100)</li> <li>• Front panel kit (92546-10358)</li> </ul>	

## Large SCARA robot for precision machining, assembly, and material handling

- EtherCAT connectivity to the Omron NJ501-R controller and programming through the familiar IEC 61131-3 programming language or scripting (eV+).
- Reach is extended to 800 mm without compromising repeatability
- High payload for screw-driving tools
- The amplifier and controller built into the robot reduces simplifies integration
- Choose the right robot for you application from two different types
- Reach 800 mm
- Maximum payload 5.5 kg
- Weight 43 kg

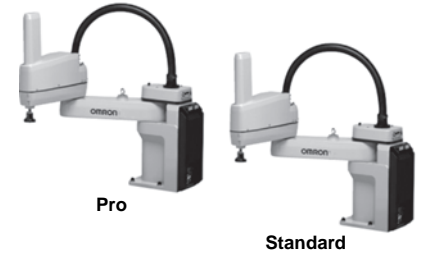

## Specifications

Product name		eCobra					
		800					
		800 Standard			800 Pro		
Size		Standard	Cleanroom	IP65	Standard	Cleanroom	IP65
Type		RL4-1168000	RL4-1168010	RL4-1168030	RL4-2168000	RL4-2168010	RL4-2168030
Cleanroom/IP							
Part Number		RL4-1168000	RL4-1168010	RL4-1168030	RL4-2168000	RL4-2168010	RL4-2168030
Number of axes		4					
Mounting		table/floor					
Reach		800 mm					
Maximum Payload		5.5 kg					
Repeatability	XY	±0.017 mm					
	Z	±0.003 mm					
	Theta	±0.019°					
Joint Range	Joint 1	±105°					
	Joint 2	±157.5°					
	Joint 3	210 mm					
	Joint 4	±360°					
Inertia Moment (Max.)	Joint 4	450 kg-cm <sup>2</sup>					
Joint Speeds	Joint 1	386°/s					
	Joint 2	720°/s					
	Joint 3	1100 mm/s					
	Joint 4	1200°/s					
Power Requirements		24 VDC: 6 A 200 to 240 VAC: 10 A, single-phase					
Protection		IP20	IP20	IP65	IP20	IP20	IP65
Clean Class		---	Class 10	---	---	Class 10	---
Environment Requirements	Ambient Temperature	5 to 40°C					
	Humidity Range	5 to 90% (non-condensing)					
Weight		43 kg					
Basic configuration	Controller	ICS-ECAT					
	On-board I/O (Input/Output)	12/8, 4 Solenoid Output					
	Conveyor tracking input	No			2		
	RS-232C serial communications port	1					
	Programming environment	Sysmac Studio 64-bit					
	ACE Sight	Yes					
	ePLC Connect	No					
	ePLC I/O	No					
Connectable controller		Omron NJ501-R Series					



# Dimensions

(Unit: mm)

## eCobra 800

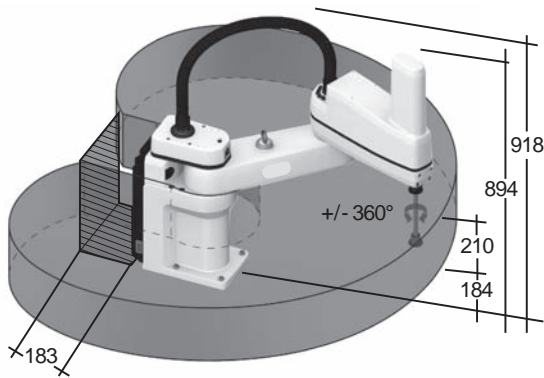

- Work Envelope: Radius 800 mm  
Inner Limit: Radius 164 mm  
Height: 210 mm
- ▨ Required clearance to open iCS-ECAT Chassis

### Tool Flange

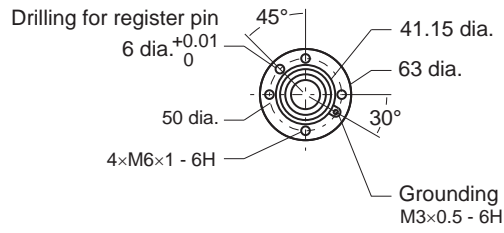

### Footprint

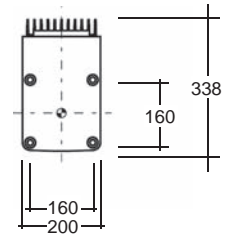

### Front panel



## Robot Parts Code and Bundled Accessories

Type	eCobra		
	Cleanroom/IP	Standard	Cleanroom
eCobra 800 Standard	RL4-1168000	RL4-1168010	RL4-1168030
eCobra 800 Pro	RL4-2168000	RL4-2168010	RL4-2168030
Overview	Robot + iCS-ECAT		
Purpose	To be used in conjunction with NJ501-R controller, which can connect up to 8 robots via EtherCAT		
Bundled Accessories	<ul style="list-style-type: none"> <li>• XSYSTEM cable with jumpers and Ethernet Management port, 1,8 m/6 ft (13323-100)</li> <li>• Front panel kit (92546-10358)</li> </ul>		

# Articulated Robots

# Viper 650

EtherCAT (NJ501-R) version

## Articulated robot for machining, assembly, and material handling

- EtherCAT connectivity to the Omron NJ501-R controller and programming through the familiar IEC 61131-3 programming language or scripting (eV+).
- High-resolution, absolute encoders to provide high accuracy, superior slow-speed following, and easy calibration
- High-efficiency, low-inertia Harmonic Drives and a lightweight arm to deliver maximum acceleration
- Reach 653 mm
- Maximum payload 5 kg
- Weight 34 kg



## Specifications

Product name		Viper		
		650		
Size		Standard	Cleanroom	IP54/65
Cleanroom/IP				
Part Number		RL6-2066000	RL6-2066020	RL6-2066010
Mounting		Table/Floor/Inverted		
Number of axes		6		
Reach		653 mm		
Maximum Payload		5 kg		
Repeatability	XYZ	±0.02 mm		
Joint Range	Joint 1	±170°		
	Joint 2	-190°, +45°		
	Joint 3	-29°, +256°		
	Joint 4	±190°		
	Joint 5	±120°		
	Joint 6	±360°		
Inertia Moment (Max.)	Joint 4	0.295 kgm <sup>2</sup>		
	Joint 5	0.295 kgm <sup>2</sup>		
	Joint 6	0.045 kgm <sup>2</sup>		
Joint Speeds	Joint 1	328°/s		
	Joint 2	300°/s		
	Joint 3	375°/s		
	Joint 4	375°/s		
	Joint 5	375°/s		
	Joint 6	600°/s		

Product name		Viper		
		650		
Size		Standard	Cleanroom	IP54/65
Cleanroom/IP				
Power Requirements		24 VDC: 6 A 200 to 240 VAC: 10 A, single-phase		
Protection	Base	IP40	IP40	IP54
	Robot Joints (J4, J5, J6)	IP40	IP40	IP65
Clean Class		---	Class10	---
Environment Requirements	Ambient Temperature	5 to 40°C		
	Humidity Range	5 to 90% (non-condensing)		
Weight		34 kg		
Basic configuration	Controller	eCS-ECAT		
	On-board I/O (Input/Output)	12/8		
	Conveyor tracking input	2		
	RS-232C serial communications port	1		
	Programming environment	Sysmac Studio 64-bit		
	ACE Sight	Yes		
	ePLC Connect	No		
	ePLC I/O	No		
Connectable controller		Omron NJ501-R Series		

# Dimensions

(Unit: mm)

## Viper 650

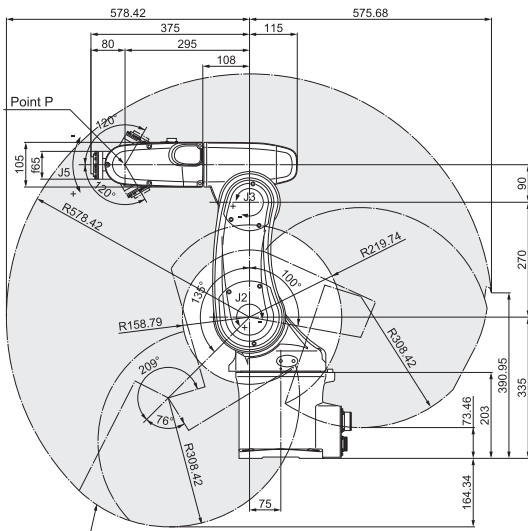

Workable space defined by point P

## Footprint

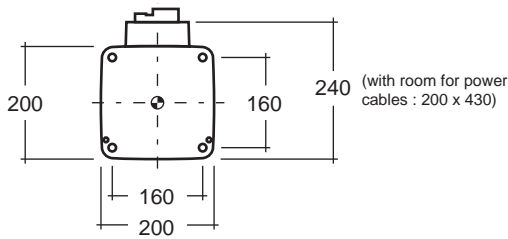

## eCS-ECAT

Weight : 8.68 kg

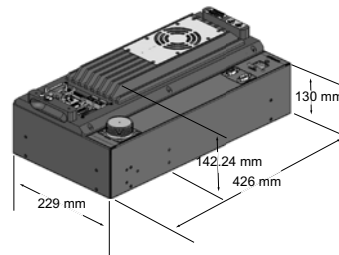

## Front panel



## Flange

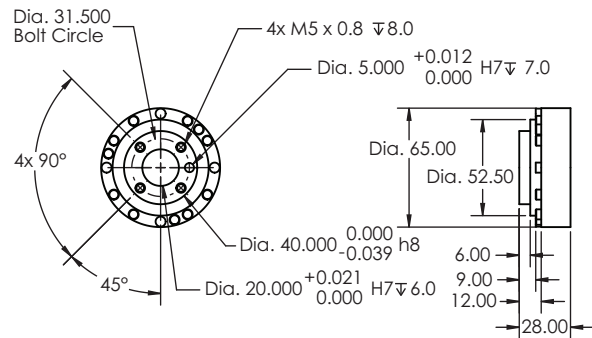

# Robot Parts Code and Bundled Accessories

Type	Viper		
	Cleanroom/IP	Standard	IP54/65
Viper 650	RL6-2066000	RL6-2066020	RL6-2066010
Overview	Robot + eCS-ECAT Robot Controller		
Purpose	To be used in conjunction with NJ501-R Series controller, which can connect up to 8 robots via EtherCAT		
Bundled Accessories	<ul style="list-style-type: none"> <li>XSYSTEM cable with jumpers and Ethernet Management port, 1.8 m/6 ft (13323-100)</li> <li>Front Panel kit (92546-10358)</li> <li>Arm power/signal cable, 4 m/13 ft                             <ul style="list-style-type: none"> <li>-Standard Model: 05020-000</li> <li>-Cleanroom &amp; IP54/65 Models: 05463-000</li> </ul> </li> </ul>		

# Articulated Robots

# Viper 850

EtherCAT (NJ501-R) version

## Articulated robot for machining, assembly, and material handling

- EtherCAT connectivity to the Omron NJ501-R controller and programming through the familiar IEC 61131-3 programming language or scripting (eV+).
- High-resolution, absolute encoders to provide high accuracy, superior slow-speed following and easy calibration.
- High-efficiency, low-inertia Harmonic Drives and a lightweight arm to deliver maximum acceleration.
- Max Reach: 855 mm
- Max Payload: 5 kg
- Weight: 36 kg



## Specifications

Product name		Viper		
		850		
		Standard	Cleanroom	IP54/65
Part Number		RL6-2068000	RL6-2068020	RL6-2068010
Mounting		Table/Floor/Inverted		
Number of axes		6		
Reach		855 mm		
Maximum Payload		5 kg		
Repeatability	XYZ	±0.03 mm		
Joint Range	Joint 1	±170°		
	Joint 2	-190°, +45°		
	Joint 3	-29°, +256°		
	Joint 4	±190°		
	Joint 5	±120°		
	Joint 6	±360°		
Inertia Moment (Max.)	Joint 4	0.295 kgm <sup>2</sup>		
	Joint 5	0.295 kgm <sup>2</sup>		
	Joint 6	0.045 kgm <sup>2</sup>		
Joint Speeds	Joint 1	250°/s		
	Joint 2	250°/s		
	Joint 3	250°/s		
	Joint 4	375°/s		
	Joint 5	375°/s		
	Joint 6	600°/s		

Product name		Viper		
		850		
		Standard	Cleanroom	IP54/65
Power Requirements		24 VDC: 6 A 200 to 240 VAC: 10 A, single-phase		
Protection	Base	IP40	IP40	IP54
	Robot Joints (J4, J5, J6)	IP40	IP40	IP65
Clean Class		---	Class10	---
Environment Requirements	Ambient Temperature	5 to 40°C		
	Humidity Range	5 to 90% (non-condensing)		
Weight		36 kg		
Basic configuration	Controller	eCS-ECAT		
	On-board I/O (Input/Output)	12/8		
	Conveyor tracking input	2		
	RS-232C serial communications port	1		
	Programming environment	Sysmac Studio 64-bit		
	ACE Sight	Yes		
	ePLC Connect	No		
	ePLC I/O	No		
Connectable controller		Omron NJ501-R Series		

# Dimensions

(Unit: mm)

## Viper 850

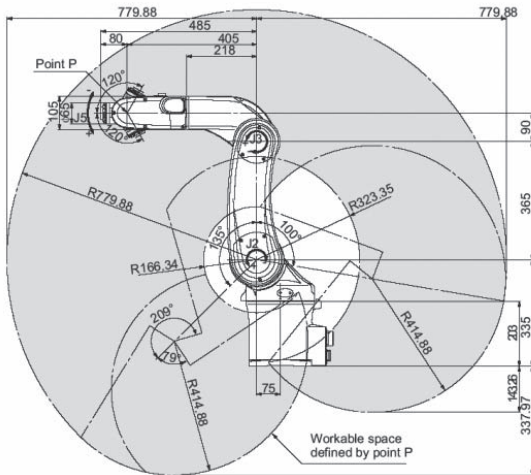

## eCS-ECAT

Weight: 8.68 kg

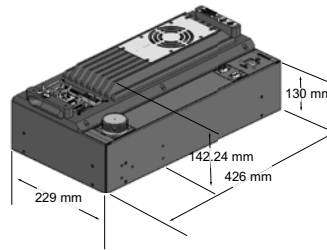

## Front panel



## Footprint

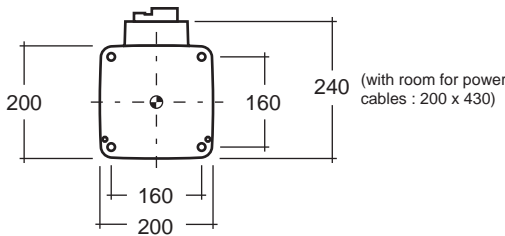

## Flange

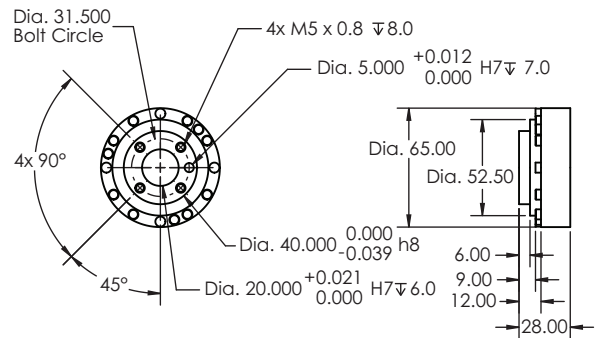

# Robot Parts Code and Bundled Accessories

Type	Viper		
	Cleanroom/IP	Standard	IP54/65
Viper 850	RL6-2068000	RL6-2068020	RL6-2068010
Overview	Robot + eCS-ECAT Robot Controller		
Purpose	To be used in conjunction with NJ501-R Series controller, which can connect up to 8 robots via EtherCAT		
Bundled Accessories	<ul style="list-style-type: none"> <li>XSYSTEM cable with jumpers and Ethernet Management port, 1.8 m/6 ft (13323-100)</li> <li>Front panel kit (92546-10358)</li> <li>Arm power/signal cable, 4 m/13 ft                             <ul style="list-style-type: none"> <li>-Standard Model: 05020-000</li> <li>-Cleanroom &amp; IP54/65 Models: 05463-000</li> </ul> </li> </ul>		

# Machine Automation Controller

# NJ501-R Series

**Controller that covers functions and high-speed processing required for machine control and safety, reliability and maintainability.**

- Integration of Robotics, Logic, and Motion in one CPU
- Conforms to IEC 61131-3 (JIS B 3503) standard programming and PLCopen function blocks for Motion Control
- Conforms to IEC 61131-3 (JIS B 3503) standard programming and traditional V+ scripting for robot and motion control
- Programming with variables allows users to create complex programs efficiently.
- Offers speed without compromising on reliability and robustness expected from PLCs.
- Complete RAS Functions: Transmission frame error check, timeout, bus diagnosis, Watchdog (WDT), memory check, and topology check, etc.
- Offers speed without compromising on reliability and robustness expected from PLCs.
- Linear and circular interpolation.
- Electronic gear and cam synchronization
- Fast and accurate control by synchronizing all EtherCAT devices, such as vision, servos, robots, and IO with the controller.
- Offers speed without compromising on reliability.



## Specifications

Item	Product Description	
Product Name	NJ501-R[ ][ ]	
Description	Machine controller with sequence, motion, and robotics functionality	
Software	Sysmac Studio	
Programming	IEC 61131-3 (Ladder, Structured Text, Function Blocks) eV+ Scripting	
Program Capacity	20 MB	
Memory Card	SD/SDHC memory card	
Variable Capacity	No retain attribute	4 MB
	Retain attribute	2 MB
Built-in Ports	EtherCAT, Ethernet/IP, USB 2.0	
Number of EtherCAT slaves	192	
Max Number of robots	8	
Max Number of Axes	64, 32, 16	
Ordering Information	P072 Sysmac Catalog	

## Sysmac studio for machine creators

Sysmac Studio provides an integrated development environment to CPU Units, NY-Series, Industrial PC, and other Machine Automation Controllers, as well as EtherCAT slaves

- One software for motion, logic sequencing, robots, safety, drives, vision and HMI.
- Fully compliant with open standard IEC 61131-3.
- Supports Ladder, Structured Text and Function Block programming with a rich instruction set and eV+ programming language for robotics.
- CAM editor for easy programming of complex motion profiles.
- Machine and Robot integrated simulation in a 3D environment.
- Advanced security function with 32 digit security password
- Capable of configuration robotics Application modules (Pack Manager, Robot Vision Manager).



## System Requirements

Item	Product Description
Ordering Information	Sysmac Studio Ver.1.[ ] [ ] Datasheet
Item	Requirement
<b>Operating system (OS)</b> *1 *2	Windows 10 (64-bit)
<b>CPU</b> *2	DOS/V (IBM AT compatible machines) personal computers equipped with Intel® Core™ i5-3xxx (3rd generation: Ivy Bridge) or equivalent/later processors are required.
<b>Main memory</b> *2	4 GB min. 8 GB min. recommended.
<b>Hard disk</b>	Minimum 8 GB of Hard disk space is required to install.
<b>Display</b>	XGA 1024 × 768, 16 million colors. WXGA 1280 × 800 min. recommended
<b>Communications ports</b>	USB port corresponded to USB 2.0, or Ethernet port *3
<b>Supported languages</b>	Japanese, English, German, French, Italian, Spanish, simplified Chinese, traditional Chinese, Korean

\*1. Sysmac Studio Operating System Precaution: System requirements and hard disk space may vary with the system environment.

\*2. If you create a user program with a memory size over 20 MB, the personal computer equipped with Intel® Core™ i7 or an equal/faster processor and the RAM of 8 GB or more is recommended.

\*3. For hardware (e.g. PC and CPU unit) connection methods and cables, refer to each hardware manuals.

**Note:** System environment for 3D simulation Option is as follows.

- DOS/V (IBM AT compatible machines) personal computers equipped with Intel® Core™ i5 8250U (1.60-3.40 GHz) or equivalent/faster processors Intel® Core™ i7 9750H min. recommended.
- 8 GB RAM min.
- 16 GB RAM min. recommended
- 1920 x 1080, 16 million colors full HD display min.

Video card: NVIDIA® GeForce® GTX1650 Ti min. recommended

## Sysmac Studio 3D Simulation

Sysmac Studio 3D Simulation simplifies operational simulations of manufacturing facilities by simply adding optional licenses for simulation functions to the Sysmac Studio programming software. Operational simulation of robots and peripheral equipment can be performed with high accuracy and real-time. In addition, this product enables visualization and preliminary verification of machine behavior before it is actually started up, thus the time required to confirm the production capacity of the equipment, start-up, and modification is shortened.

### Main Features:

- Use only the Sysmac Studio with loaded 3D CAD data\*1 for 3D simulations. Operation of a control program created during machine development can be verified in a virtual environment. This improves program accuracy during design, reducing rework at verification using physical devices and saving development time.
- Simulations can be used to test feasibility during process design or to share the same understanding between mechanical and electrical designers during operation design, improving design quality and engineering efficiency.

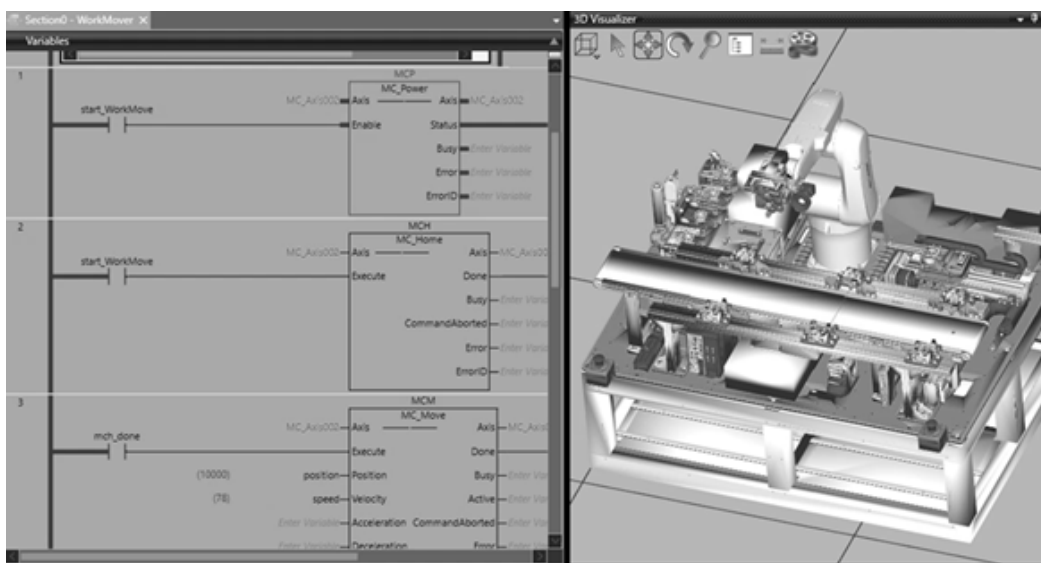

Item	Product Description
Ordering Information	Sysmac Studio Ver.1.[ ] [ ] Datasheet

\*1. 3D CAD data supports STEP/IGES



# Application Manager

Sysmac Studio provides another layer of simplification for Application development, by means of the Application Manager modules. These modules enable advanced programming capabilities for Packaging (PackManager) and Vision (Robot Vision Manager) applications.

**PackManager** can manage scalable packaging lines from integration to deployment and step-by-step guidance without scripting. The software walks you through the configuration of packaging application by setting up process-specific items, such as controllers, robots, and conveyor belts.

### Main Features:

- Process Manager optimizes the resources, decreasing idle time and maximizing the amount of parts processed per robot.
- Fully customizable for any line configuration and advanced load balancing.

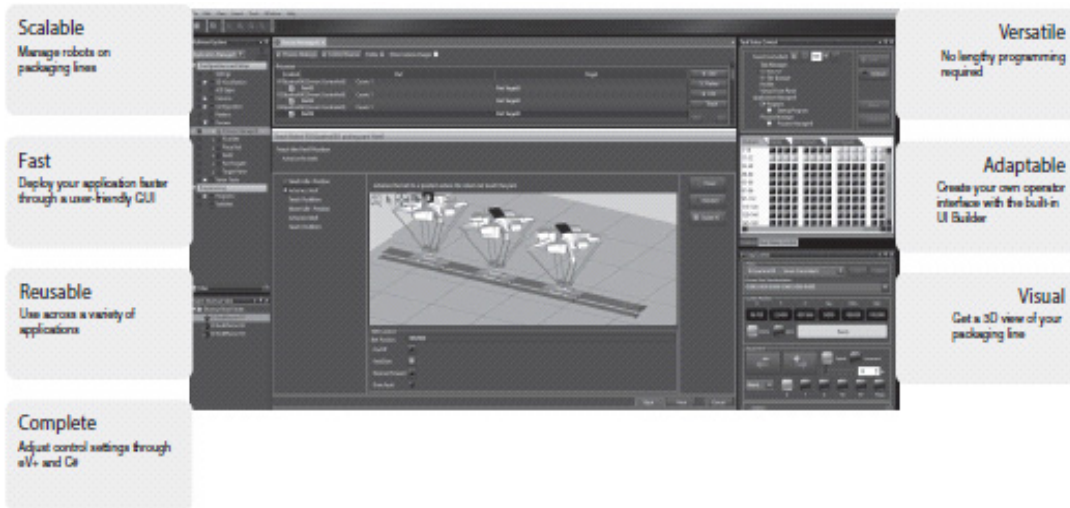

**Robot Vision Manager** provides algorithms and tools for easily integrated vision systems into robotic applications. Camera calibration, part identification, and image processing tools are supported as part of this Manager.

Application Manager modules are configured through Sysmac Studio and executed on Omron’s IPC Application Controller.

## Application Manager License Configuration

License	Part Number	Item
PackManager	20409-000	Enables full functionality of the PackManager software
Robot Vision Manager	20410-000	Enables the Robot Vision Manager functionality and inspection tools library
Dual (PackManager plus Vision)	20433-000	Enables functionality of both PackManager and Robot Vision Manager

## System Requirements

Item	Requirement
Operating system (OS)	Windows 7 (64-bit version) / (Windows 10 (64-bit version)
CPU	Intel® Core™ i5 or equivalent or faster recommended.
Main memory	2 GB min.(8 GB recommended)
Video memory	512 MB min.
Hard disk	At least 1 GB of available space
Display	XGA 1024 x 768, 16 million colors. WXGA 1280 x 800 min. recommended
Communications ports	USB port (for hardware key), Ethernet port
Supported languages	English, French, German, Japanese, Spanish, Italian, Korean, Simplified Chinese, Traditional Chinese

# Standalone Robotics & Software





# Hornet 565

**Parallel robot ideal for use in the food and beverage, pharmaceutical, and healthcare industries**



- Programmable through ACE software and eV+ language, or through the familiar IEC 61131-3 when using ePLC Connect
- The amplifier and controller built into the robot reduces the number of cables
- Tracks up to a conveyor speed of 1.4 m/s
- Designed with a high payload to support multi-hand (multi-picking)
- Supports fast Pick & Place on a fast conveyor
- Helps reduce mounting cost and robot vibration
- Maximum working diameter 1,130 mm
- Working height 425 mm
- Maximum payload 8 kg
- Weight 52 kg

## Specifications

Product name		Hornet				
Size		565				
Number of axes		3 Axis		4 Axis		
IP		Standard	IP65/67	Standard	IP65/67	
Part Number		1720[ ]-45600	1720[ ]-45610	1720[ ]-45604	1720[ ]-45614	
Mounting		inverted				
Working volume	X,Y axis (stroke)	1130 mm				
	Z axis (stroke)	425 mm				
	theta axis (rotation angle)	-		±360°		
Maximum Payload		8 kg		3 kg		
Repeatability		±0.10 mm				
Cycle times, sustained, 20°C ambient *1	Payload 0.1 kg	0.32 s		0.35 s		
	Payload 1.0 kg	0.34 s		0.37 s		
	Payload 3.0 kg	0.38 s		0.42 s		
Power Requirements		24 VDC: 6 A 200 to 240 VAC: 10 A, single-phase				
Protection	Base	Topside of robot	IP20	IP65	IP20	IP65
		Underside of robot	IP65			
	Platform, Arms		IP67			
Environment Requirements	Ambient Temperature		1 to 40°C			
	Humidity Range		5 to 90% (non-condensing)			
Weight		52 kg				
Basic configuration	Controller		eAIB			
	On-board I/O (Input/Output)		12/8			
	Conveyor tracking input		2			
	RS-232C serial communications port		1			
	Programming environment		ACE, ePLC			
	ACE Sight		Yes			
	ePLC Connect		Yes			
ePLC I/O		Yes				
Connectable controller *2		SmartController EX, NJ/NX/NY Series *3				

\*1. Adept cycle, in mm (25/305/25)

\*2. Choose a controller to suit your application.

\*3. The robot version 2.3.C or later is required to connect with the NJ/NX/NY Series.

# Dimensions

(Unit: mm)

## Hornet 565

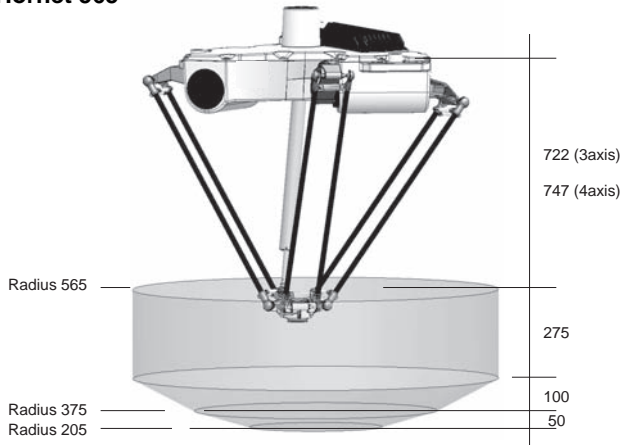

## Front panel



## Flange

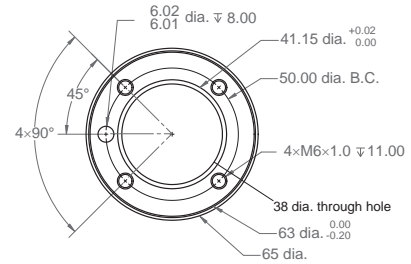

## Footprint

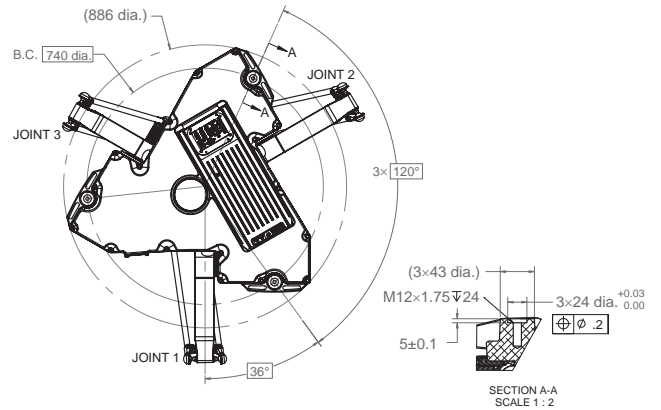

# Robot Parts Code and Bundled Accessories

Type	Hornet		Hornet Add-On	
	Standard	IP65/67	Standard	IP65/67
<b>Hornet 565 3 Axis</b>	17201-45600	17201-45610	17203-45600	17203-45610
<b>Hornet 565 4 Axis</b>	17201-45604	17201-45614	17203-45604	17203-45614
<b>Overview</b>	Robot + eAIB with fully integrated controller		Robot + eAIB required connection cables	
<b>Purpose</b>	Typical for use in single robot system		Typically added to systems with an existing SmartController EX to create multi-robot systems	
<b>Bundled Accessories</b>	<ul style="list-style-type: none"> <li>XSYSTEM cable with jumpers, 1.8 m/6 ft (13323-000)</li> <li>Front panel kit (92546-10358)</li> </ul>	<ul style="list-style-type: none"> <li>XSYSTEM cable with jumpers, 1.8 m/6 ft (13323-000)</li> <li>Front panel kit (92546-10358)</li> <li>Cable Seal Kit (08765-000)</li> </ul>	<ul style="list-style-type: none"> <li>XSYSTEM cable with jumpers, 1.8 m/6 ft (13323-000)</li> <li>XSYS cable, 4.5 m/15 ft (11585-000)</li> <li>DB9 splitter (00411-000)</li> <li>1394 latch cable, 4.5 m/15 ft (13632-045)</li> <li>eV+ license to connect to controller (14529-103)</li> </ul>	<ul style="list-style-type: none"> <li>XSYSTEM cable with jumpers, 1.8 m/6 ft (13323-000)</li> <li>XSYS cable, 4.5 m/15 ft (11585-000)</li> <li>DB9 splitter (00411-000)</li> <li>1394 latch cable, 4.5 m/15 ft (13632-045)</li> <li>eV+ license to connect to controller (14529-103)</li> <li>Cable Seal Kit (08765-000)</li> </ul>

# Quattro 650H/HS

## Four-axis parallel robot achieves high speed and high precision

- Programmable through ACE software and eV+ language, or through the familiar IEC 61131-3 when using ePLC Connect.
- Four-axis arm evenly distributes the load on the robot
- Fast and high-precision conveyance and assembly
- Designed with a high payload to support multi-hand (multi-picking)
- Supports fast Pick & Place on a fast conveyor
- Meets the sanitary standards of the United States Department of Agriculture for prevention of product contamination
- Maximum working diameter 1,300 mm
- Working height 500 mm
- Maximum payload 15 kg
- Weight 117 kg



## Specifications

Product name		Quattro			
Size		650			
Type		H		HS	
IP		Standard	IP65/67	Standard	
Part Number		1721-2600[ ]	1721[ ]-2602[ ]	1721[ ]-2601[ ]	
Number of axes		4			
Mounting		inverted			
Working volume	X,Y axis (stroke)	1300 mm			
	Z axis (stroke)	500 mm			
	theta axis (rotation angle)	0° (fixed) (P30)			
		±46.25° (P31)			
±92.5° (P32)					
±185° (P34)					
Maximum Payload		6 kg (P30: 15 kg)		3 kg (P30: 12 kg)	
Repeatability		±0.10 mm			
Cycle times, sustained, at 20°C ambient	Payload 0.1 kg	0.30 s *1, 0.46 s *2		0.39 s *1, 0.55 s *2	
	Payload 1.0 kg	0.36 s *1, 0.47 s *2		0.41 s *1, 0.58 s *2	
	Payload 2.0 kg	0.37 s *1, 0.52 s *2		0.42 s *1, 0.59 s *2	
	Payload 4.0 kg	0.41 s *1, 0.58 s *2		-	
	Payload 6.0 kg	0.43 s *1, 0.61 s *2		-	
Power Requirements		24 VDC: 11 A (eAIB, SmartController) 200 to 240 VAC: 10 A, single-phase			
Protection	Base	Topside of robot	IP20	IP65	IP66
		Underside of robot	IP65	IP65	IP66
	Platform, Arms		IP67		
Environment Requirements	Ambient Temperature		1 to 40°C		
	Humidity Range		5 to 90% (non-condensing)		
Weight		117 kg			
USDA-Accepted for meat and poultry processing		---	---	Yes	
Basic configuration	Controller		SmartController EX		
	On-board I/O (Input/Output)		12/8		
	Conveyor tracking input		4		
	RS-232C serial communications port		1		
	Programming environment		ACE, ePLC		
	ACE Sight		Yes		
	ePLC Connect		Yes		
ePLC I/O		Yes			
Connectable controller *3		SmartController EX, NJ/NX/NY Series *4			

\*1. Adept cycle, in mm (25/305/25)

\*2. Extended cycle, in mm (25/700/25)

\*3. Choose a controller to suit your application.

\*4. The robot version 2.3.C or later is required to connect with the NJ/NX/NY Series.

# Dimensions

(Unit: mm)

## Quattro 650H/HS

Note: The figure shows the HS type.

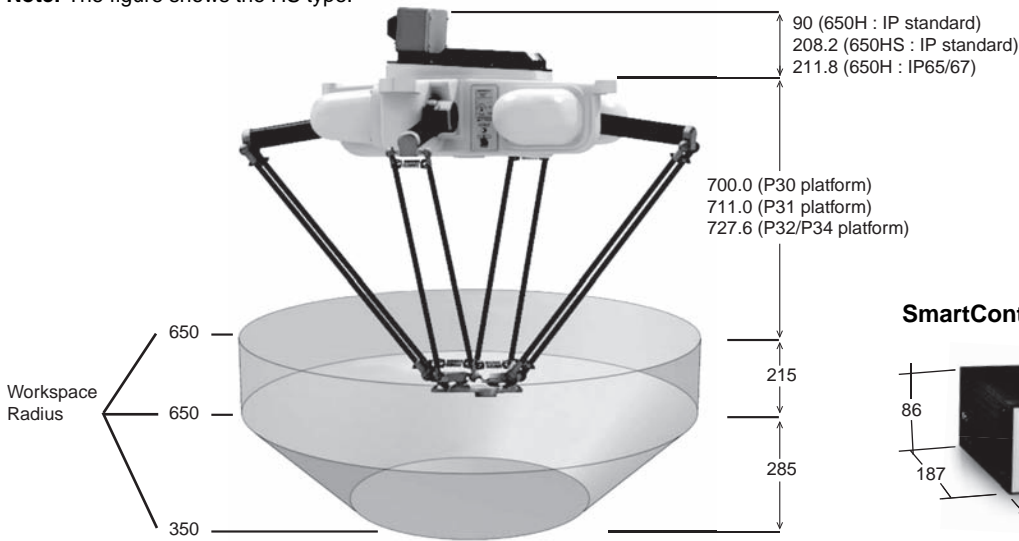





## Front panel



## SmartController EX



Four choices of platform offer different ranges of rotation.

Appearance				
Type	P30	P31	P32	P34
Rotation angle	No rotation	±46.25°	±92.5°	±185°
Maximum Payload	H: 15 kg, HS: 12 kg	H: 6 kg, HS: 3 kg	H: 6 kg, HS: 3 kg	H: 6 kg, HS: 3 kg

Note: The platform appearances of the H type are shown above. The platform of the HS type is made of stainless steel.

# Robot Parts Code and Bundled Accessories

Type	Quattro with EX Controller			Quattro Add-On		
IP	Standard (H)	Standard (HS)	IP65/67	Standard (H)	Standard (HS)	IP65/67
Quattro P30	17214-26000	17214-26010	17214-26020	17213-26000	17213-26010	17213-26020
Quattro P31	17214-26001	17214-26011	17214-26021	17213-26001	17213-26011	17213-26021
Quattro P32	17214-26002	17214-26012	17214-26022	17213-26002	17213-26012	17213-26022
Quattro P34	17214-26004	17214-26014	17214-26024	17213-26004	17213-26014	17213-26024
Overview	Robot + eAIB+ SmartController EX + required connection cables			Robot + eAIB + required connection cables		
Purpose	Typical for use in single robot system and multi-robot systems.			Typically added to systems with an existing SmartController EX to create multi-robot systems		
Bundled Accessories	<ul style="list-style-type: none"> <li>SmartController EX (09200-000)</li> <li>XSYS cable, 4.5 m/15 ft (11585-000)</li> <li>1394 latch cable, 4.5 m/15 ft (13632-045)</li> <li>Front panel kit (92546-10358)</li> <li>eV+ license to connect to controller (14529-103)</li> </ul>	<ul style="list-style-type: none"> <li>SmartController EX (09200-000)</li> <li>XSYS cable, 4.5 m/15 ft (11585-000)</li> <li>1394 latch cable, 4.5 m/15 ft (13632-045)</li> <li>Front panel kit (92546-10358)</li> <li>eV+ license to connect to controller (14529-103)</li> <li>Cable Seal Kit (09564-000)</li> </ul>	<ul style="list-style-type: none"> <li>SmartController EX (09200-000)</li> <li>XSYS cable, 4.5 m/15 ft (11585-000)</li> <li>1394 latch cable, 4.5 m/15 ft (13632-045)</li> <li>Front panel kit (92546-10358)</li> <li>eV+ license to connect to controller (14529-103)</li> <li>Cable Seal Kit (08765-000)</li> </ul>	<ul style="list-style-type: none"> <li>XSYS cable, 4.5 m/15 ft (11585-000)</li> <li>DB9 splitter (00411-000)</li> <li>1394 latch cable, 4.5 m/15 ft (13632-045)</li> <li>eV+ license to connect to controller (14529-103)</li> </ul>	<ul style="list-style-type: none"> <li>XSYS cable, 4.5 m/15 ft (11585-000)</li> <li>DB9 splitter (00411-000)</li> <li>1394 latch cable, 4.5 m/15 ft (13632-045)</li> <li>eV+ license to connect to controller (14529-103)</li> <li>Cable Seal Kit (09564-000)</li> </ul>	<ul style="list-style-type: none"> <li>XSYS cable, 4.5 m/15 ft (11585-000)</li> <li>DB9 splitter (00411-000)</li> <li>1394 latch cable, 4.5 m/15 ft (13632-045)</li> <li>eV+ license to connect to controller (14529-103)</li> <li>Cable Seal Kit (08765-000)</li> </ul>

# Quattro 800H/HS

## Four-axis parallel robot achieves high speed and high precision

- Programmable through ACE software and eV+ language, or through the familiar IEC 61131-3 when using ePLC Connect
- Four-axis arm evenly distributes the load on the robot
- Fast and high-precision conveyance and assembly
- Designed with a high payload to support multi-hand (multi-picking)
- Supports fast Pick & Place on a fast conveyor
- Meets the sanitary standards of the United States Department of Agriculture for prevention of product contamination
- Maximum working diameter 1,600 mm
- Working height 500 mm
- Maximum payload 10 kg
- Weight 117 kg



## Specifications

Product name		Quattro		
		800		HS
Size		H		
Type		Standard	IP65/67	Standard
IP				
Part Number		1721[ ]-2630[ ]	1720[ ]-2632[ ]	1721[ ]-2631[ ]
Number of axes		4		
Mounting		inverted		
Working volume		X,Y axis (stroke)		
		1600 mm		
		Z axis (stroke)		
		500 mm		
theta axis (rotation angle)		0° (fixed) (P30)		
		±46.25° (P31)		
		±92.5° (P32)		
		±185° (P34)		
Maximum Payload		4 kg (P30:10 kg)		1 kg (P30: 7 kg)
Repeatability		±0.10 mm		
Cycle times, sustained (at 20°C ambient)		Payload 0.1 kg		-
		Payload 1.0 kg		0.33 s *1, 0.48 s *2
		Payload 2.0 kg		0.38 s *1, 0.50 s *2
		Payload 4.0 kg		0.40 s *1, 0.55 s *2
Power Requirements		24 VDC: 11 A (eAIB, SmartController) 200 to 240 VAC: 10 A, single-phase		
Protection		Base		
		Platform, Arms		IP67
Environment Requirements		Topside of robot		IP66
		Underside of robot		IP66
Ambient Temperature		1 to 40°C		
Humidity Range		5 to 90% (non-condensing)		
USDA-Accepted for meat and poultry processing		---		Yes
Weight		117 kg		
Basic configuration		Controller		
		SmartController EX		
		On-board I/O (Input/Output)		
		12/8		
		Conveyor tracking input		
		4		
		RS-232C serial communications port		
3				
Programming environment		ACE, ePLC		
ACE Sight		Yes		
ePLC Connect		Yes		
ePLC I/O		Yes		
Connectable controller *3		SmartController EX, NJ/NX/NY Series *4		

\*1. Adept cycle, in mm (25/305/25)

\*2. Extended cycle, in mm (25/700/25)

\*3. Choose a controller to suit your application.

\*4. The robot version 2.3.C or later is required to connect with the NJ/NX/NY Series.



# Dimensions

(Unit: mm)

## Quattro 800H/HS



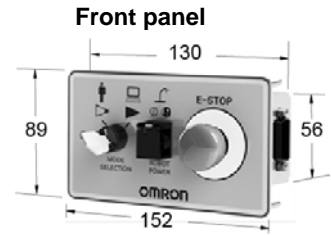
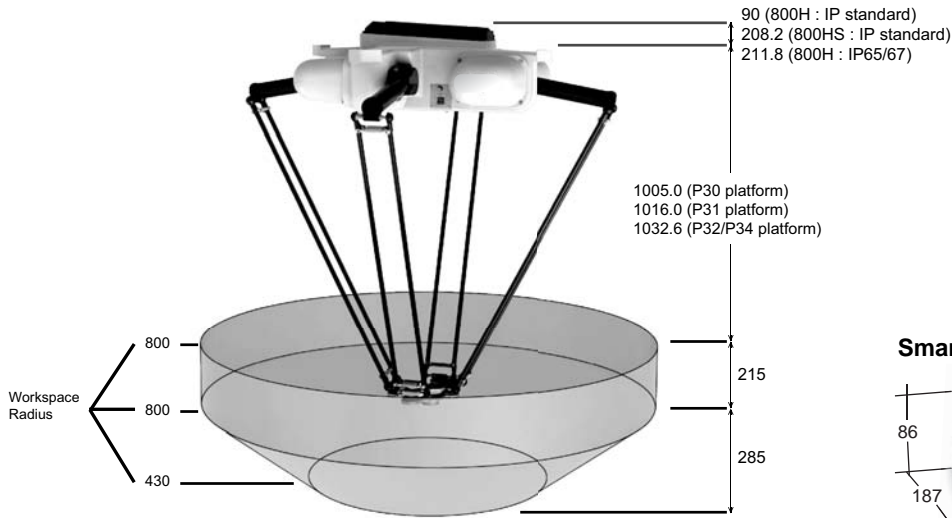

Note: The figure shows the H type.



## SmartController EX



Four choices of platform offer different ranges of rotation.

Appearance				
Type	P30	P31	P32	P34
Rotation angle	No rotation	±46.25°	± 92.5°	±185°
Maximum Payload	H: 10 kg, HS: 7 kg	H: 4 kg, HS: 1 kg	H: 4 kg, HS: 1 kg	H: 4 kg, HS: 1 kg

Note: The platform appearances of the H type are shown above. The platform of the HS type is made of stainless steel.

## Robot Parts Code and Bundled Accessories

Type	Quattro with EX Controller			Quattro Add-On		
	Standard (H)	Standard (HS)	IP65/67	Standard (H)	Standard (HS)	IP65/67
Quattro P30	17214-26300	17214-26310	17214-26320	17213-26300	17213-26310	17213-26320
Quattro P31	17214-26301	17214-26311	17214-26321	17213-26301	17213-26311	17213-26321
Quattro P32	17214-26302	17214-26312	17214-26322	17213-26302	17213-26312	17213-26322
Quattro P34	17214-26304	17214-26314	17214-26324	17213-26304	17213-26314	17213-26324
Overview	Robot + eAIB+ SmartController EX + required connection cables			Robot + eAIB + required connection cables		
Purpose	Typical for use in single robot system and multi-robot systems.			Typically added to systems with an existing SmartController EX to create multi-robot systems		
Bundled Accessories	<ul style="list-style-type: none"> <li>SmartController EX (09200-000)</li> <li>XSYS cable, 4.5 m/15 ft (11585-000)</li> <li>1394 latch cable, 4.5 m/15 ft (13632-045)</li> <li>Front panel kit (92546-10358)</li> <li>eV+ license to connect to controller (14529-103)</li> </ul>	<ul style="list-style-type: none"> <li>SmartController EX (09200-000)</li> <li>XSYS cable, 4.5 m/15 ft (11585-000)</li> <li>1394 latch cable, 4.5 m/15 ft (13632-045)</li> <li>Front panel kit (92546-10358)</li> <li>eV+ license to connect to controller (14529-103)</li> <li>Cable Seal Kit (09564-000)</li> </ul>	<ul style="list-style-type: none"> <li>SmartController EX (09200-000)</li> <li>XSYS cable, 4.5 m/15 ft (11585-000)</li> <li>1394 latch cable, 4.5 m/15 ft (13632-045)</li> <li>Front panel kit (92546-10358)</li> <li>eV+ license to connect to controller (14529-103)</li> <li>Cable Seal Kit (08765-000)</li> </ul>	<ul style="list-style-type: none"> <li>XSYS cable, 4.5 m/15 ft (11585-000)</li> <li>DB9 splitter (00411-000)</li> <li>1394 latch cable, 4.5 m/15 ft (13632-045)</li> <li>eV+ license to connect to controller (14529-103)</li> <li>Cable Seal Kit (09564-000)</li> </ul>	<ul style="list-style-type: none"> <li>XSYS cable, 4.5 m/15 ft (11585-000)</li> <li>DB9 splitter (00411-000)</li> <li>1394 latch cable, 4.5 m/15 ft (13632-045)</li> <li>eV+ license to connect to controller (14529-103)</li> <li>Cable Seal Kit (08765-000)</li> </ul>	<ul style="list-style-type: none"> <li>XSYS cable, 4.5 m/15 ft (11585-000)</li> <li>DB9 splitter (00411-000)</li> <li>1394 latch cable, 4.5 m/15 ft (13632-045)</li> <li>eV+ license to connect to controller (14529-103)</li> <li>Cable Seal Kit (08765-000)</li> </ul>

# i4-350L/450L/550L

## New i4L robot for precision machining, assembly, and material handling

- High payload, inertia, and repeatability in a compact size for use in digital assembly applications.
- Compact, easy to install design. Mountable on table or wall without additional HW. Available with bottom or rear interface panel orientations.
- Easy to service with high visibility, multi-colored LED light dome provides convenient indication of the robot status.
- Reach Options: 350 mm, 450 mm, 550 mm
- Maximum payload: 5 kg
- Weight 350: 15.1 kg; 450: 15.9 kg; 550 (180 mm): 16.4 kg; 550 (350 mm): 16.5 kg



## Specifications

Product		i4-350L		i4-450L		i4-550L			
Type		Standard		Standard		Standard		Long-Quill	
Interface Panel Orientation		Rear Panel	Bottom Panel	Rear Panel	Bottom Panel	Rear Panel	Bottom Panel	Rear Panel	Bottom Panel
Part Number		RS4-2053002	RS4-2053102	RS4-2054002	RS4-2054102	RS4-2055002	RS4-2055102	RS4-2055004	RS4-2055104
Number of axes		4							
Reach (mm)		350		450		550			
Maximum Payload (kg)		5							
Quill Length (mm)		180				350			
Repeatability	XY (mm)	±0.01							
	Z (mm)	±0.01							
	Theta (deg)	±0.01							
Joint Range	Joint 1 (deg)	±135							
	Joint 2 (deg)	±135		±148					
	Joint 3 (mm)	180				350			
	Joint 4 (deg)	±360							
Inertia Moment (Max.)	Joint 4 (kg m <sup>2</sup> )		0.05						
Maximum push force - vertical	Joint 3 (N)		150						
Joint Speeds	Joint 1 (deg/s)	456							
	Joint 2 (deg/s)	456							
	Joint 3 (mm/s)	800							
	Joint 4 (deg/s)	6000							
Cycle times*1	Burst (s)	0.54		0.48					
	Sustained (s)	0.57		0.57		0.54			
	Blended Burst (s) *2	0.45		0.42		0.38			
Power Requirements		24 VDC: 5 A 48 VDC:20 A							
Protection		IP20 / NEMA Type 1							
Environment Requirements	Ambient Temperature	5 to 40°C							
	Humidity Range	5 to 90% non-condensing							
Weight (kg)		15.1		15.9		16.4		16.5	
Basic Configuration	Controller	iCS-ENET							
	On-board I/O	8 outputs / 12 inputs (Primary Interface Panel) 4 outputs / 5 inputs (Secondary Interface Panel)							
	Pneumatic pass-through connections	3							
	Conveyor tracking input	2							
	RS-232C serial comm port	1							
	Programming Environment	ACE							
	Vision Manager	Yes							
Pack Manager	Yes								
Connectable Controller		IPC Application Controller							

\*1. Adept cycle, in mm 25/305/25 (seconds, at 20°C ambient) with 2.0 kg payload

\*2. Fast cycle, in mm (25/305/25) (seconds, at 20°C ambient) with 2.0 kg payload but with arc motion

# Dimensions

(Unit: mm)

## i4-350L Dimensions

### i4 350L Work Envelope

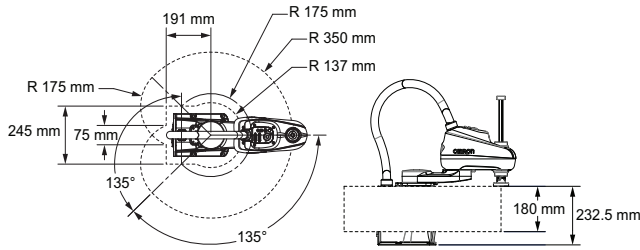

## i4 450L Dimensions

### i4 450L Work Envelope

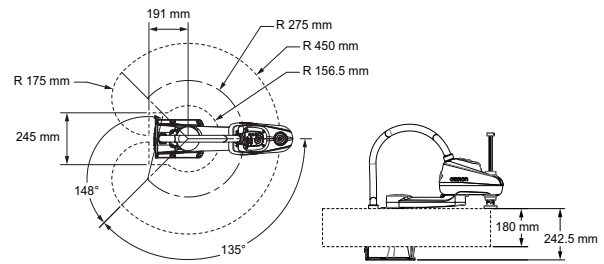

## i4-550L Dimensions

### i4 550L Work Envelope

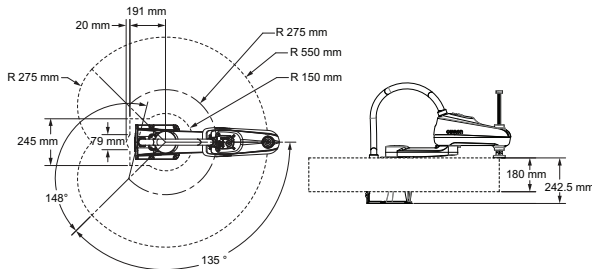

## i4-550L Long Quill Dimensions

### i4 550L Long Quill Work Envelope

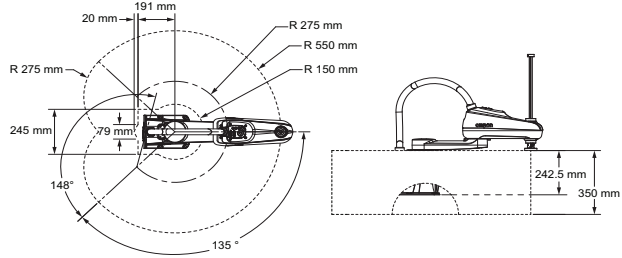

## Mounting Options

### Table Cable Exit Cut-Out Dimensions

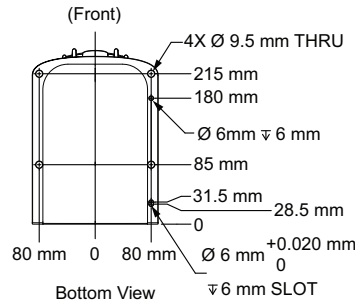
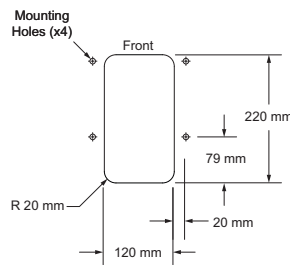
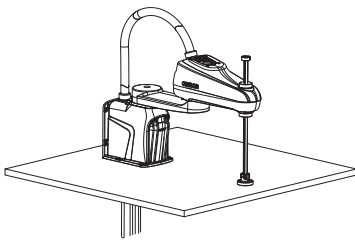

### Wall Cable Exit Cut-Out Dimensions

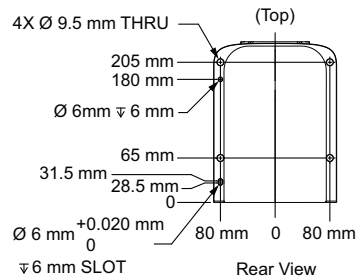
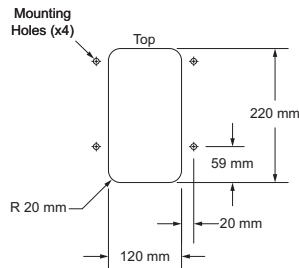
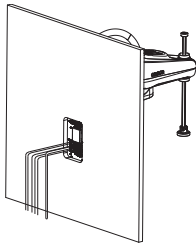

## Flange

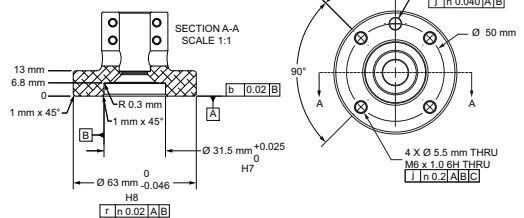

## Front Panel



# Robot Parts Code and Bundled Accessories

Product	i4-350L		i4-450L		i4-550L			
	Standard		Standard		Standard		Long-Quill	
Interface Panel Orientation	Rear Panel	Bottom Panel	Rear Panel	Bottom Panel	Rear Panel	Bottom Panel	Rear Panel	Bottom Panel
Part Number	RS4-2053002	RS4-2053102	RS4-2054002	RS4-2054102	RS4-2055002	RS4-2055102	RS4-2055004	RS4-2055104
Overview	SCARA Robot Arm + Integrated iCS ENET Controller							
Bundled Accessories	XSYSTEM cable with jumpers, and Ethernet Management port, 1.8 m/6 ft (13323-100) Front Panel Kit (92546-10358)							

# Cobra 450

## Mid-size SCARA robot for material handling, assembly, precision machining and adhesive application

- Programmable through ACE software and eV+ language, or through the familiar IEC 61131-3 when using ePLC Connect.
- Good repeatability for precision assembly
- High Payload for using tools for screw-driving and adhesive application
- Minimum footprint with separate controller
- Robot with integral power and signal cables
- Reach 450 mm
- Maximum Payload 5 kg
- Weight 29 kg



## Specifications

Product name		<b>Cobra</b>
	Size	<b>450</b>
Part Number		1720[ ]-14500
Number of axes		4
Mounting		table/floor
Reach		450 mm
Maximum Payload		5 kg
Repeatability	XY	±0.02 mm
	Z	±0.01 mm
	Theta	±0.005°
Joint Range	Joint 1	±125°
	Joint 2	±145°
	Joint 3	200 mm
	Joint 4	±360°
Inertia Moment (Max.)	Joint 4	450 kg-cm <sup>2</sup>
Joint Speeds	Joint 1	450°/s
	Joint 2	720°/s
	Joint 3	1100 mm/s
	Joint 4	1940°/s
Cycle times, *1 with 2.0 kg Payload	Burst	0.49 s
	Sustained	0.64 s
Power Requirements		24 VDC: 6 A 200 to 240 VAC: 10 A, single-phase
Protection		IP20
Clean Class		---
Environment Requirements	Ambient Temperature	5 to 40°C
	Humidity Range	35 to 90% (non-condensing)
Weight		29 kg
Basic configuration	Controller	eMotionBlox-40
	On-board I/O (Input/Output)	12/8
	Conveyor tracking input	2
	RS-232C serial communications port	1
	Programming environment	ACE, ePLC
	ACE Sight	Yes
	ePLC Connect	Yes
ePLC I/O	Yes	
Connectable controller *2		eMotionBlox-40M, SmartController EX, NJ/NX/NY Series

\*1. Adept cycle, in mm 25/305/25 (seconds, at 20°C ambient)

\*2. Choose a controller to suit your application.

# Dimensions

(Unit: mm)

## Cobra 450

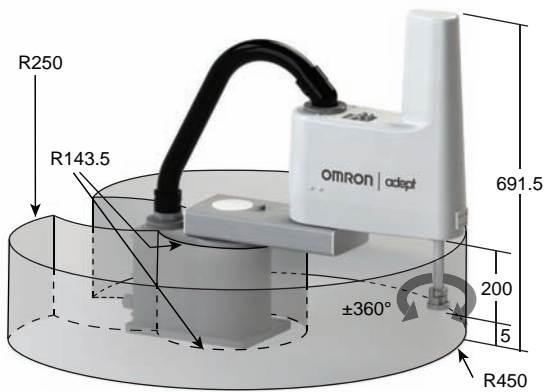

## eMotionBlox-40M



Weight : 9.3 kg

## Flange

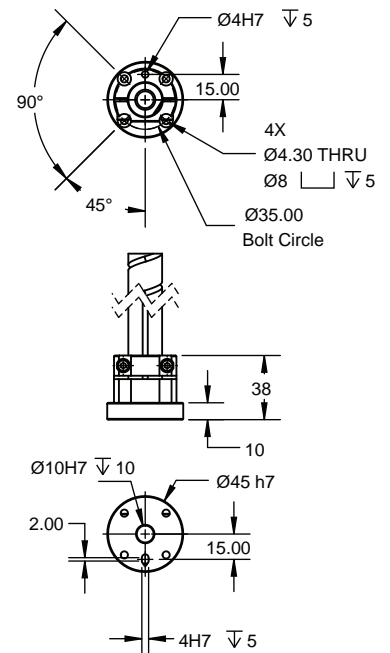

## Footprint

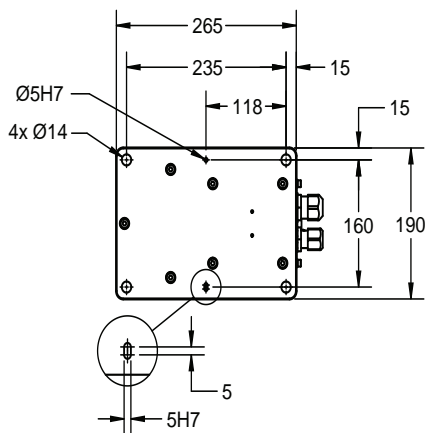

## Front panel (option)



# Robot Parts Code and Bundled Accessories

Type	Cobra 450	Cobra 450 Add-On
Cobra 450	17201-14500	17203-14500
Overview	Robot + Integral Power and Signal Cables + eMotionBlox-40M amplifier with fully-integrated controls	Robot + Integral Power and Signal Cables + eMotionBlox-40M amplifier + required connection cables
Purpose	Typical for use in single-robot system	Typically added to systems with an existing SmartController EX to create multi-robot systems
Bundled Cable/Accessories	XSYSTEM cable with jumpers, 1.8 m/6 ft (13323-000)	<ul style="list-style-type: none"> <li>XSYSTEM cable with jumpers, 1.8 m/6 ft (13323-000)</li> <li>XSYS cable, 4.5 m/15 ft (11585-000)</li> <li>DB9 splitter (00411-000)</li> <li>1394 latch cable, 4.5 m/15 ft (13632-045)</li> <li>eV+ license to connect to controller (14529-103)</li> </ul>

# Cobra 500

## Mid-size SCARA robot for material handling, assembly, precision machining and adhesive application

- Programmable through ACE software and eV+ language, or through the familiar IEC 61131-3 when using ePLC Connect.
- Good repeatability for precision assembly
- High Payload for using tools for screw-driving and adhesive application
- Minimum footprint with separate controller
- Robot with integral power and signal cables
- Reach 500 mm
- Maximum Payload 5 kg
- Weight 29 kg



## Specifications

Product name		<b>Cobra</b>
	Size	<b>500</b>
Part Number		1720[ ]-15000
Number of axes		4
Mounting		table/floor
Reach		500 mm
Maximum Payload		5 kg
Repeatability	XY	±0.02 mm
	Z	±0.01 mm
	Theta	±0.005°
Joint Range	Joint 1	±125°
	Joint 2	±145°
	Joint 3	200 mm
	Joint 4	±360°
Inertia Moment (Max.)	Joint 4	450 kg-cm <sup>2</sup>
Joint Speeds	Joint 1	450°/s
	Joint 2	720°/s
	Joint 3	1120 mm/s
	Joint 4	1940°/s
Cycle times, *1 with 2.0 kg Payload	Burst	0.51 s
	Sustained	0.60 s
Power Requirements		24 VDC: 6 A 200 to 240 VAC: 10 A, single-phase
Protection		IP20
Clean Class		---
Environment Requirements	Ambient Temperature	5 to 40°C
	Humidity Range	35 to 90% (non-condensing)
Weight		29 kg
Basic configuration	Controller	eMotionBlox-40
	On-board I/O (Input/Output)	12/8
	Conveyor tracking input	2
	RS-232C serial communications port	1
	Programming environment	ACE, PackXpert, ePLC
	ACE Sight	Yes
	ePLC Connect	Yes
ePLC I/O	Yes	
Connectable controller *2		eMotionBlox-40M, SmartController EX, NJ/NX/NY Series

\*1. Adept cycle, in mm 25/305/25 (seconds, at 20°C ambient)

\*2. Choose a controller to suit your application.

# Dimensions

(Unit: mm)

## Cobra 500

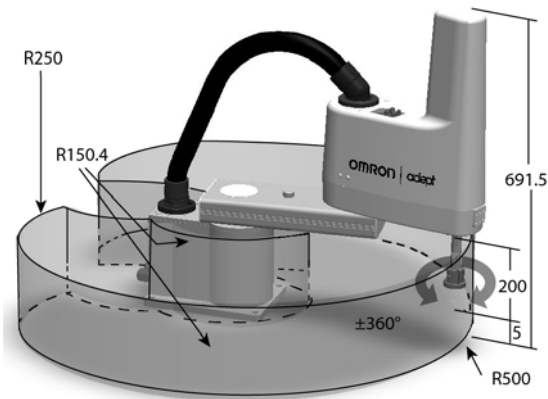

## eMotionBlox-40M



## Flange

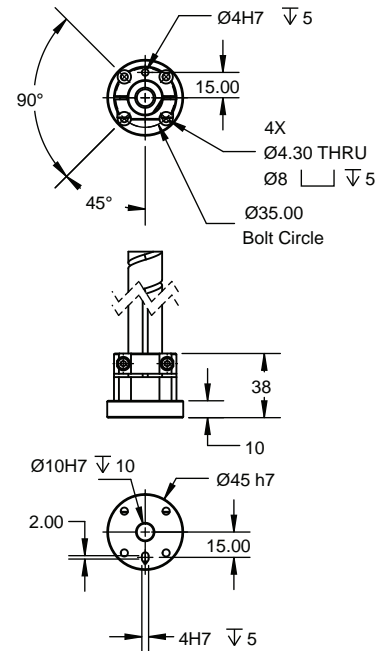

## Footprint

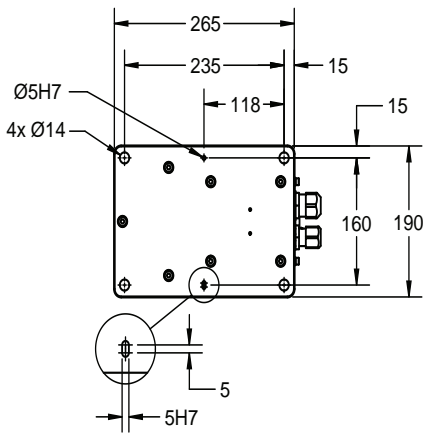

## Front panel (option)



# Robot Parts Code and Bundled Accessories

Type	Cobra 500	Cobra 500 Add-On
<b>Cobra 500</b>	17201-15000	17203-15000
<b>Overview</b>	Robot + Integral Power and Signal Cables + eMotionBlox-40M amplifier with fully-integrated controls	Robot + Integral Power and Signal Cables + eMotionBlox-40M amplifier + required connection cables
<b>Purpose</b>	Typical for use in single-robot system	Typically added to systems with an existing SmartController EX to create multi-robot systems
<b>Bundled Cable/Accessories</b>	XSYSTEM cable with jumpers, 1.8 m/6 ft (13323-000)	<ul style="list-style-type: none"> <li>XSYSTEM cable with jumpers, 1.8 m/6 ft (13323-000)</li> <li>XSYS cable, 4.5 m/15 ft (11585-000)</li> <li>DB9 splitter (00411-000)</li> <li>1394 latch cable, 4.5 m/15 ft (13632-045)</li> <li>eV+ license to connect to controller (14529-103)</li> </ul>

# Cobra 650

## Mid-size SCARA robot for material handling, assembly, precision machining and adhesive application

- Programmable through ACE software and eV+ language, or through the familiar IEC 61131-3 when using ePLC Connect
- Good repeatability for precision assembly
- High Payload for using tools for screw-driving and adhesive application
- Minimum footprint with separate controller
- Robot with integral power and signal cables
- Reach 650 mm
- Maximum Payload 5 kg
- Weight 31 kg



## Specifications

Product name		<b>Cobra</b>
	Size	<b>650</b>
Part Number		1720[ ]-16500
Number of axes		4
Mounting		table/floor
Reach		650 mm
Maximum Payload		5 kg
Repeatability	XY	±0.02 mm
	Z	±0.01 mm
	Theta	±0.005°
Joint Range	Joint 1	±125°
	Joint 2	±145°
	Joint 3	200 mm
	Joint 4	±360°
Inertia Moment (Max.)	Joint 4	450 kg·cm <sup>2</sup>
Joint Speeds	Joint 1	450°/s
	Joint 2	720°/s
	Joint 3	1120 mm/s
	Joint 4	1940°/s
Cycle times, *1 with 2.0 kg Payload	Burst	0.43 s
	Sustained	0.60 s
Power Requirements		24 VDC: 6 A 200 to 240 VAC: 10 A, single-phase
Protection		IP20
Clean Class		---
Environment Requirements	Ambient Temperature	5 to 40°C
	Humidity Range	35 to 90% (non-condensing)
Weight		31 kg
Basic configuration	Controller	eMotionBlox-40
	On-board I/O (Input/Output)	12/8
	Conveyor tracking input	2
	RS-232C serial communications port	1
	Programming environment	ACE, ePLC
	ACE Sight	Yes
	ePLC Connect	Yes
ePLC I/O	Yes	
Connectable controller *2		eMotionBlox-40M, SmartController EX, NJ/NX/NY Series

\*1. Adept cycle, in mm 25/305/25 (seconds, at 20°C ambient)

\*2. Choose a controller to suit your application.



# Dimensions

(Unit: mm)

## Cobra 650

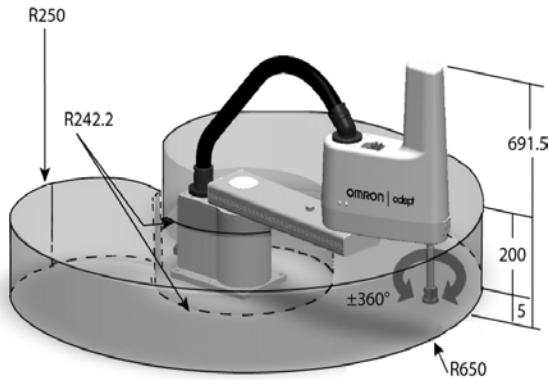

## eMotionBlox-40M



## Flange

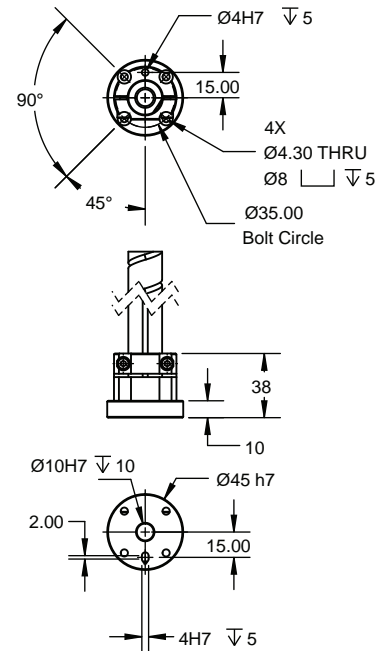

## Footprint

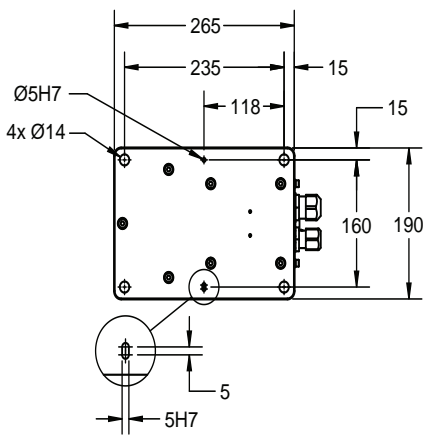

## Front panel (option)



# Robot Parts Code and Bundled Accessories

Type	Cobra 650	Cobra 650 Add-On
<b>Cobra 650</b>	17201-16500	17203-16500
<b>Overview</b>	Robot + Integral Power and Signal Cables + eMotionBlox-40M amplifier with fully-integrated controls	Robot + Integral Power and Signal Cables + eMotionBlox-40M amplifier + required connection cables
<b>Purpose</b>	Typical for use in single-robot system	Typically added to systems with an existing SmartController EX to create multi-robot systems
<b>Bundled Cable/Accessories</b>	XSYSTEM cable with jumpers, 1.8 m/6 ft (13323-000)	<ul style="list-style-type: none"> <li>XSYSTEM cable with jumpers, 1.8 m/6 ft (13323-000)</li> <li>XSYS cable, 4.5 m/15 ft (11585-000)</li> <li>DB9 splitter (00411-000)</li> <li>1394 latch cable, 4.5 m/15 ft (13632-045)</li> <li>eV+ license to connect to controller (14529-103)</li> </ul>

# eCobra 600 Lite/Standard/Pro

## Mid-size SCARA robot for precision machining, assembly, and material handling

- Ethernet capability to control the robot through the familiar programming language (IEC 61131-3) of Machine Automation Controller NJ/NX/NY Series
- High repeatability suitable for material handling and precision assembly
- High payload for screw-driving tools
- Amplifier and controller built into the robot reduces the number of cables
- Choose the right robot for you application from three different types
- Reach 600 mm
- Maximum payload 5.5 kg
- Weight 41 kg

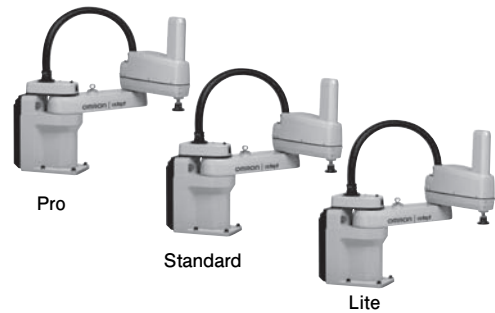

## Specifications

Product name		eCobra					
		600					
		600 Lite		600 Standard		600 Pro	
Type		Standard	Cleanroom	Standard	Cleanroom	Standard	Cleanroom
Cleanroom							
Part Number		17010-16000	17010-16010	1711[ ]-16000	1711[ ]-16010	1721[ ]-16000	1721[ ]-16010
Number of axes		4					
Mounting		table/floor					
Reach		600 mm					
Maximum Payload		5.5 kg					
Repeatability	XY	±0.017 mm					
	Z	±0.003 mm					
	Theta	±0.019°					
Joint Range	Joint 1	±105°					
	Joint 2	±157.5°					
	Joint 3	210 mm					
	Joint 4	±360°					
Inertia Moment (Max.)	Joint 4	450 kg·cm <sup>2</sup>					
Joint Speeds	Joint 1	386°/s					
	Joint 2	720°/s					
	Joint 3	1100 mm/s					
	Joint 4	1200°/s					
Cycle times *1 (Payload 2.0 kg)	Burst	0.66 s		0.55 s		0.39 s	
	Sustained	0.66 s		0.55 s		0.45 s	
Power Requirements		24 VDC: 6 A 200 to 240 VAC: 10 A, single-phase					
Protection		IP20					
Clean Class		---	Class 10	---	Class 10	---	Class 10
Environment Requirements	Ambient Temperature	5 to 40°C					
	Humidity Range	5 to 90% (non-condensing)					
Weight		41 kg					
Basic configuration	Controller	eAIB					
	On-board I/O (Input/Output)	12/8, 4 Solenoid Output					
	Conveyor tracking input	No				2	
	RS-232C serial communications port	No	1				
	Programming environment	ACE	ACE, PackXpert, ePLC				
	ACE Sight	No *2	Yes				
	ePLC Connect	No	Yes				
	ePLC I/O	No				Yes	
Connectable controller *3		No	SmartController EX, NJ/NX/NY Series *4				

\*1. Adept cycle, in mm 25/305/25 (seconds, at 20°C ambient)

\*2. The SmartVision MX cannot be used with the Lite type.

\*3. Choose a controller to suit your application.

\*4. The robot version 2.3.C or later is required to connect with the NJ/NX/NY Series.

# Dimensions

(Unit: mm)

## eCobra 600

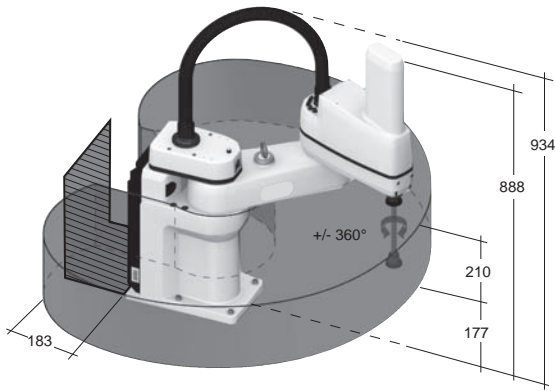

- Work Envelope: Radius 600 mm  
Inner Limit: Radius 163 mm  
Height: 210 mm
- Required clearance to open eAIB Chassis

### Flange

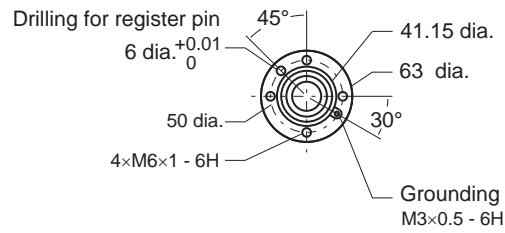

### Footprint

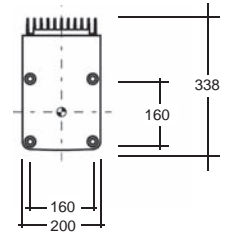

### Front panel



## Robot Parts Code and Bundled Accessories

Type	eCobra		eCobra Add-On	
	Cleanroom	Standard	Cleanroom	Standard
eCobra 600 Lite	17010-16000	17010-16010	---	---
eCobra 600 Standard	17111-16000	17111-16010	17113-16000	17113-16010
eCobra 600 Pro	17211-16000	17211-16010	17213-16000	17213-16010
Overview	Robot + eAIB with fully integrated controls		Robot + eAIB with required connection cables	
Purpose	Typical for use in single robot system		Typically added to systems with an existing SmartController EX to create multi-robot systems	
Bundled Accessories	<ul style="list-style-type: none"> <li>XSYSTEM cable with jumpers, 1.8 m/6 ft (13323-000)</li> <li>Front panel kit (92546-10358)</li> </ul>		<ul style="list-style-type: none"> <li>XSYSTEM cable with jumpers, 1.8 m/6 ft (13323-000)</li> <li>XSYS cable, 4.5 m/15 ft (11585-000)</li> <li>DB9 splitter (00411-000)</li> <li>1394 latch cable, 4.5 m/15 ft (13632-045)</li> <li>eV+ license to connect to controller (14529-103)</li> </ul>	

# eCobra 800 Lite/Standard/Pro

## Large SCARA robot for precision machining, assembly, and material handling

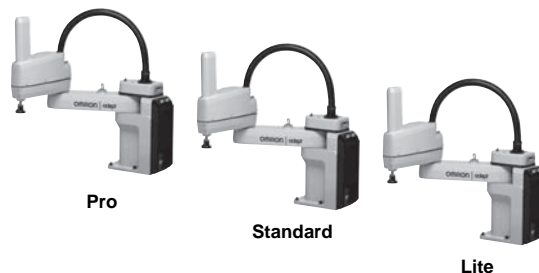

- Ethernet capability to control the robot through the familiar programming language (IEC 61131-3) of Machine Automation Controller NJ/NX/NY Series
- Reach is extended to 800 mm without compromising repeatability
- High payload for screw-driving tools
- The amplifier and controller built into the robot reduces the number of cables
- Choose the right robot for you application from three different types
- Reach 800 mm
- Maximum payload 5.5 kg
- Weight 43 kg

## Specifications

Product name		eCobra								
		800								
		800 Lite			800 Standard			800 Pro		
Size		Standard	Cleanroom	IP65	Standard	Cleanroom	IP65	Standard	Cleanroom	IP65
Type										
Cleanroom/IP										
Part Number		17010-18000	17010-18010	17010-18030	1711[ ]-18000	1711[ ]-18010	1711[ ]-18030	1721[ ]-18000	1721[ ]-18010	1721[ ]-18030
Number of axes		4								
Mounting		table/floor								
Reach		800 mm								
Maximum Payload		5.5 kg								
Repeatability	XY	±0.017 mm								
	Z	±0.003 mm								
	Theta	±0.019°								
Joint Range	Joint 1	±105°								
	Joint 2	±157.5°								
	Joint 3	210 mm								
	Joint 4	±360°								
Inertia Moment (Max.)	Joint 4	450 kg-cm <sup>2</sup>								
Joint Speeds	Joint 1	386°/s								
	Joint 2	720°/s								
	Joint 3	1100 mm/s								
	Joint 4	1200°/s								
Cycle times (Payload 2.0 kg)	Burst *1	0.73 s			0.62 s			0.44 s		
	Sustained *1	0.73 s			0.62 s			0.54 s		
Power Requirements		24 VDC: 6 A 200 to 240 VAC: 10 A, single-phase								
Protection		IP20	IP20	IP65	IP20	IP20	IP65	IP20	IP20	IP65
Clean Class		---	Class 10	---	---	Class 10	---	---	Class 10	---
Environment Requirements	Ambient Temperature	5 to 40°C								
	Humidity Range	5 to 90% (non-condensing)								
Weight		43 kg								
Basic configuration	Controller	eAIB								
	On-board I/O (Input/Output)	12/8, 4 Solenoid Output								
	Conveyor tracking input	No						2		
	RS-232C serial communications port	No			1					
	Programming environment	ACE			ACE, PackXpert, ePLC					
	ACE Sight	No *2			Yes					
	ePLC Connect	No			Yes					
ePLC I/O	No						Yes			
Connectable controller *3		No			SmartController EX, NJ/NX/NY Series *4					

\*1. Adept cycle, in mm 25/305/25 (seconds, at 20°C ambient)

\*2. The SmartVision MX cannot be used with the Lite type.

\*3. Choose a controller to suit your application.

\*4. The robot version 2.3.C or later is required to connect with the NJ/NX/NY Series.

# Dimensions

(Unit: mm)

## eCobra 800

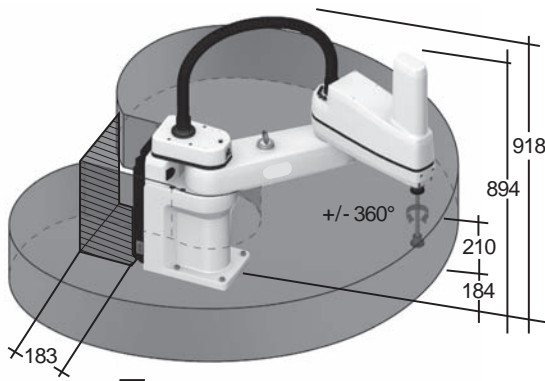

- Work Envelope: Radius 800 mm  
Inner Limit: Radius 164 mm  
Height: 210 mm
- Required clearance to open iCS-ECAT Chassis

### Flange

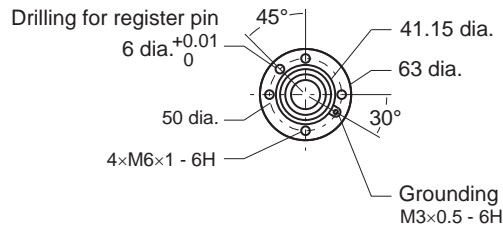

### Footprint

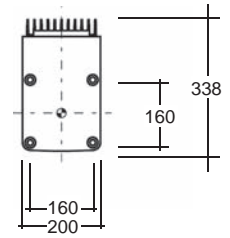

### Front panel



## Robot Parts Code and Bundled Accessories

Type	eCobra			eCobra Add-On			
	Cleanroom/IP	Standard	Cleanroom	IP65	Standard	Cleanroom	IP65
eCobra 800 Lite	17010-18000	17010-18010	17010-18030	---	---	---	---
eCobra 800 Standard	17111-18000	17111-18010	17111-18030	17113-18000	17113-18010	17113-18030	17113-18030
eCobra 800 Pro	17211-18000	17211-18010	17211-18030	17213-18000	17213-18010	17213-18030	17213-18030
Overview	Robot + eAIB with fully integrated controls			Robot + eAIB with required connection cables			
Purpose	Typical for use in single robot system			Typically added to systems with an existing SmartController EX to create multi-robot systems			
Bundled Accessories	<ul style="list-style-type: none"> <li>XSYSTEM cable with jumpers, 1.8 m/6 ft (13323-000)</li> <li>Front panel kit (92546-10358)</li> </ul>		<ul style="list-style-type: none"> <li>XSYSTEM cable with jumpers, 1.8 m/6 ft (13323-000)</li> <li>Front panel kit (92546-10358)</li> <li>Cable Seal Kit (04813-000)</li> </ul>	<ul style="list-style-type: none"> <li>XSYSTEM cable with jumpers, 1.8 m/6 ft (13323-000)</li> <li>XSYS cable, 4.5 m/15 ft (11585-000)</li> <li>DB9 splitter (00411-000)</li> <li>1394 latch cable, 4.5 m/15 ft (13632-045)</li> <li>eV+ license to connect to controller (14529-103)</li> </ul>	<ul style="list-style-type: none"> <li>XSYSTEM cable with jumpers, 1.8 m/6 ft (13323-000)</li> <li>XSYS cable, 4.5 m/15 ft (11585-000)</li> <li>DB9 splitter (00411-000)</li> <li>1394 latch cable, 4.5 m/15 ft (13632-045)</li> <li>eV+ license to connect to controller (14529-103)</li> <li>Cable Seal Kit (04813-000)</li> </ul>		

# eCobra 800 Inverted Lite/Standard/Pro

## Overhead-mount large SCARA robot for precision machining, assembly, and material handling

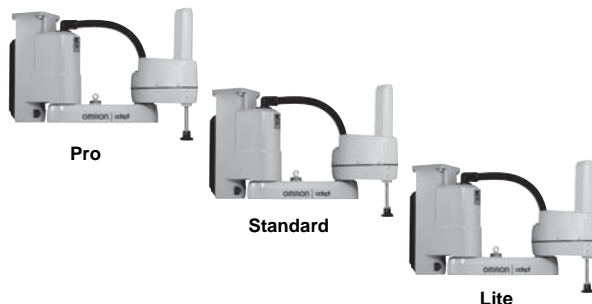

- Ethernet capability to control the robot through the familiar programming language (IEC 61131-3) of Machine Automation Controller NJ/NX/NY Series
- Overhead-mounting configuration for efficient use of space
- High payload for screw-driving tools
- The amplifier and controller built into the robot reduces the number of cables
- Choose the right robot for you application from three different types
- Reach 800 mm
- Maximum payload 5.5 kg
- Weight 51 kg

## Specifications

Product name		eCobra Inverted								
Size		800								
Type		800 Lite			800 Standard			800 Pro		
Cleanroom/IP		Standard	Cleanroom	IP65	Standard	Cleanroom	IP65	Standard	Cleanroom	IP65
Part Number		17010-18400	17010-18410	17010-18430	1711[ ]-18400	1711[ ]-18410	1711[ ]-18430	1721[ ]-18400	1721[ ]-18410	1721[ ]-18430
Number of axes		4								
Mounting		inverted								
Reach		800 mm								
Maximum Payload		5.5 kg								
Repeatability	XY	±0.017 mm								
	Z	±0.003 mm								
	Theta	±0.019°								
Joint Range	Joint 1	±123.5°								
	Joint 2	±156.5°								
	Joint 3	210 mm								
	Joint 4	±360°								
Inertia Moment (Max.)	Joint 4	450 kg·cm <sup>2</sup>								
Joint Speeds	Joint 1	386°/s								
	Joint 2	720°/s								
	Joint 3	1100 mm/s								
	Joint 4	1200°/s								
Power Requirements		24 VDC: 6 A 200 to 240 VAC: 10 A								
Protection		IP20	IP20	IP65	IP20	IP20	IP65	IP20	IP20	IP65
Clean Class		---	Class 10	---	---	Class 10	---	---	Class 10	---
Environment Requirements	Ambient Temperature	5 to 40°C								
	Humidity Range	5 to 90% (non-condensing)								
Weight		51 kg								
Basic configuration	Controller	eAIB								
	On-board I/O (Input/Output)	12/8, 4 Solenoid Output								
	Conveyor tracking input	No						2		
	RS-232C serial communications port	No			1					
	Programming environment	ACE			ACE, PackXpert, ePLC					
	ACE Sight	No *1			Yes					
	ePLC Connect	No			Yes					
ePLC I/O	No						Yes			
Connectable controller *2		No			SmartController EX, NJ/NX/NY Series *3					

\*1. The SmartVision MX cannot be used with the Lite type.  
 \*2. Choose a controller to suit your application.  
 \*3. The robot version 2.3.C or later is required to connect with the NJ/NX/NY Series.

# Dimensions

(Unit: mm)

## eCobra Inverted 800

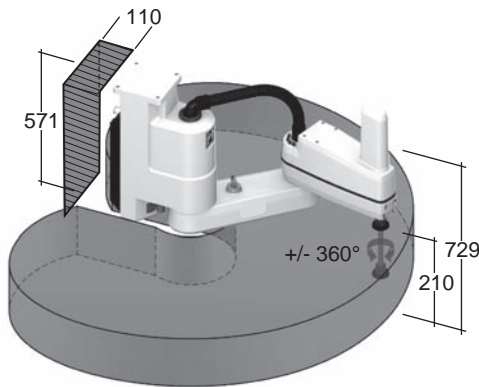

- Work Envelope: Radius 800 mm  
Inner Limit: Radius 167 mm  
Height: 210 mm
- Required clearance to open eAIB Chassis

## Flange

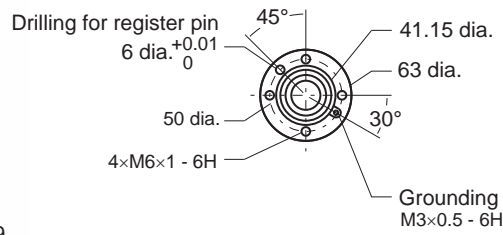

## Footprint

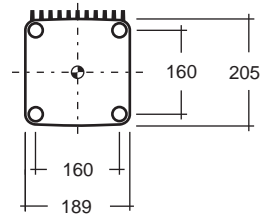

## Front panel



# Robot Parts Code and Bundled Accessories

Type	eCobra			eCobra Add-On			
	Cleanroom/IP	Standard	Cleanroom	IP65	Standard	Cleanroom	IP65
eCobra 800 Inverted Lite	17010-18400	17010-18410	17010-18430	---	---	---	---
eCobra 800 Inverted Standard	17111-18400	17111-18410	17111-18430	17113-18400	17113-18410	17113-18430	17113-18430
eCobra 800 Inverted Pro	17211-18400	17211-18410	17211-18430	17213-18400	17213-18410	17213-18430	17213-18430
Overview	Robot + eAIB with fully integrated controls			Robot + eAIB with required connection cables			
Purpose	Typical for use in single robot system			Typically added to systems with an existing SmartController EX to create multi-robot systems			
Bundled Accessories	<ul style="list-style-type: none"> <li>• XSYSTEM cable with jumpers, 1.8 m/6 ft (13323-000)</li> <li>• Front panel kit (92546-10358)</li> </ul>		<ul style="list-style-type: none"> <li>• XSYSTEM cable with jumpers, 1.8 m/6 ft (13323-000)</li> <li>• Front panel kit (92546-10358)</li> <li>• Cable Seal Kit (09073-000)</li> </ul>	<ul style="list-style-type: none"> <li>• XSYSTEM cable with jumpers, 1.8 m/6 ft (13323-000)</li> <li>• XSYS cable, 4.5 m/15 ft (11585-000)</li> <li>• DB9 splitter (00411-000)</li> <li>• 1394 latch cable, 4.5 m/15 ft (13632-045)</li> <li>• eV+ license to connect to controller (14529-103)</li> </ul>			

# Articulated Robots

# Viper 650

## Articulated robot for machining, assembly, and material handling

- Programmable through ACE software and eV+ language, or through the familiar IEC 61131-3 when using ePLC Connect.
- Diagnostics display enables faster trouble shooting
- High-resolution, absolute encoders to provide high accuracy, superior slow-speed following, and easy calibration
- High-efficiency, low-inertia Harmonic Drives and a lightweight arm to deliver maximum acceleration
- Reach 653 mm
- Maximum payload 5 kg
- Weight 34 kg



## Specifications

Product name		Viper		
		650		
Size		Standard	Cleanroom	IP54/65
Cleanroom/IP				
Part Number		1720[ ]-36000	1720[ ]-36020	1720[ ]-36010
Mounting		Table/Floor/Inverted		
Number of axes		6		
Reach		653 mm		
Maximum Payload		5 kg		
Repeatability	XYZ	±0.02 mm		
Joint Range	Joint 1	±170°		
	Joint 2	-190°, +45°		
	Joint 3	-29°, +256°		
	Joint 4	±190°		
	Joint 5	±120°		
	Joint 6	±360°		
Inertia Moment (Max.)	Joint 4	0.295 kgm <sup>2</sup>		
	Joint 5	0.295 kgm <sup>2</sup>		
	Joint 6	0.045 kgm <sup>2</sup>		
Joint Speeds	Joint 1	328°/s		
	Joint 2	300°/s		
	Joint 3	375°/s		
	Joint 4	375°/s		
	Joint 5	375°/s		
	Joint 6	600°/s		

Product name		Viper		
		650		
Size		Standard	Cleanroom	IP54/65
Cleanroom/IP				
Power Requirements		24 VDC: 6 A 200 to 240 VAC: 10 A, single-phase		
Protection	Base	IP40	IP40	IP54
	Robot Joints (J4, J5, J6)	IP40	IP40	IP65
Clean Class		---	Class10	---
Environment Requirements	Ambient Temperature	5 to 40°C		
	Humidity Range	5 to 90% (non-condensing)		
Weight		34 kg		
cULus Compliant		(Yes) *1		
Basic configuration	Controller	eMotionBlox-60R		
	On-board I/O (Input/Output)	12/8		
	Conveyor tracking input	2		
	RS-232C serial communications port	1		
	Programming environment	ACE, ePLC		
	ACE Sight	Yes		
	ePLC Connect	Yes		
	ePLC I/O	Yes		
Connectable controller *2		eMotionBlox-60R, SmartController EX, NJ/NX/NY Series *3		

\*1. cULus option

\*2. Choose a controller to suit your application.

\*3. The robot version 2.3.C or later is required to connect with the NJ/NX/NY Series.



# Dimensions

(Unit: mm)

## Viper 650

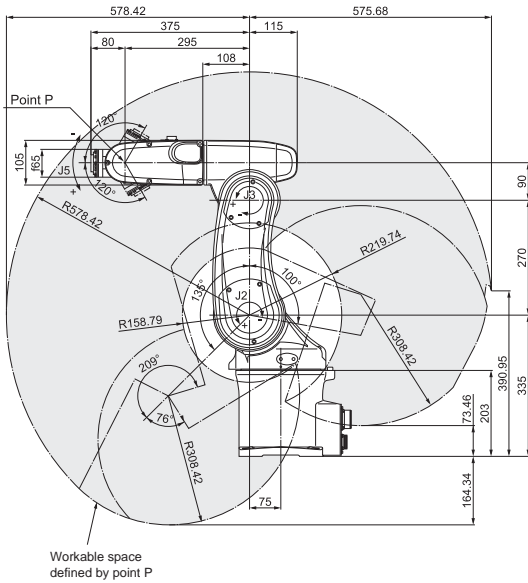

## eMotionBlox-60R

Weight : 9.3 kg

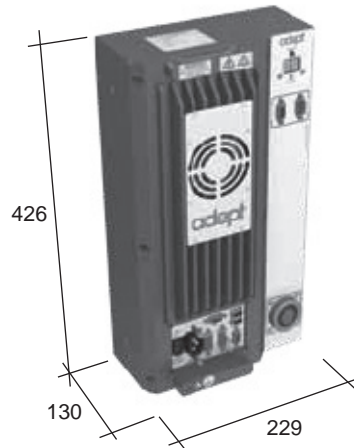

## Front panel



## Footprint

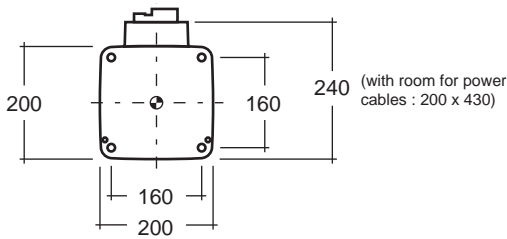

## Flange

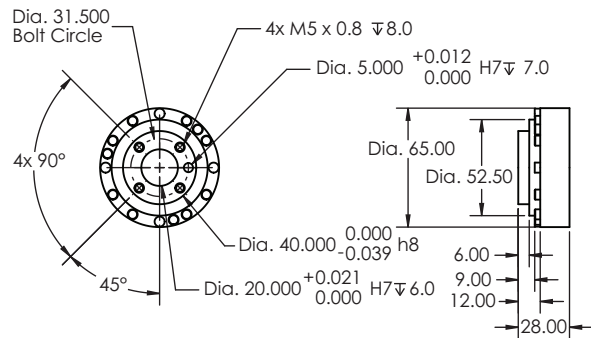

# Robot Parts Code and Bundled Accessories

Type	Viper			Viper Add-On			
	Cleanroom/IP	Standard	Cleanroom	IP54/65	Standard	Cleanroom	IP54/65
<b>Viper 650</b>		17201-36000	17201-36020	17201-36010	17203-36000	17203-36020	17203-36010
<b>Overview</b>	Robot + eMotionBlox-60R amplifier with fully integrated controls			Robot + eMotionBlox-60R + required connection cables			
<b>Purpose</b>	Typical for use in single robot system			Typically added to systems with an existing SmartController EX to create multi-robot systems			
<b>Bundled Accessories</b>	<ul style="list-style-type: none"> <li>XSYSTEM cable with jumpers, 1.8 m/6 ft (13323-000)</li> <li>Front panel kit (92546-10358)</li> <li>Arm power/signal cable, 4 m/13 ft                             <ul style="list-style-type: none"> <li>Standard Model: 05020-000</li> <li>Cleanroom &amp; IP54/65 Models: 05463-000</li> </ul> </li> </ul>			<ul style="list-style-type: none"> <li>XSYSTEM cable with jumpers, 1.8 m/6 ft (13323-000)</li> <li>XSYS cable, 4.5 m/15 ft (11585-000)</li> <li>DB9 splitter (00411-000)</li> <li>1394 latch cable, 4.5 m/15 ft (13632-045)</li> <li>eV+ license to connect to controller (14529-103)</li> </ul>			

# Articulated Robots

# Viper 850

## Articulated robot for machining, assembly, and material handling

- Programmable through ACE software and eV+ language, or through the familiar IEC 61131-3 when using ePLC Connect.
- Diagnostics display enables faster trouble shooting
- High-resolution, absolute encoders to provide high accuracy, superior slow-speed following, and easy calibration
- High-efficiency, low-inertia Harmonic Drives and a lightweight arm to deliver maximum acceleration
- Reach 855 mm
- Maximum payload 5 kg
- Weight 36 kg



## Specifications

Product name		Viper		
		850		
		Standard	Cleanroom	IP54/65
Part Number		1720[ ]-38000	1720[ ]-38020	1720[ ]-38010
Mounting		Table/Floor/Inverted		
Number of axes		6		
Reach		855 mm		
Maximum Payload		5 kg		
Repeatability	XYZ	±0.03 mm		
Joint Range	Joint 1	±170°		
	Joint 2	-190°, +45°		
	Joint 3	-29°, +256°		
	Joint 4	±190°		
	Joint 5	±120°		
	Joint 6	±360°		
Inertia Moment (Max.)	Joint 4	0.295 kgm <sup>2</sup>		
	Joint 5	0.295 kgm <sup>2</sup>		
	Joint 6	0.045 kgm <sup>2</sup>		
Joint Speeds	Joint 1	250°/s		
	Joint 2	250°/s		
	Joint 3	250°/s		
	Joint 4	375°/s		
	Joint 5	375°/s		
	Joint 6	600°/s		

Product name		Viper		
		850		
		Standard	Cleanroom	IP54/65
Power Requirements		24 VDC: 6 A 200 to 240 VAC: 10 A, single-phase		
Protection	Base	IP40	IP40	IP54
	Robot Joints (J4, J5, J6)	IP40	IP40	IP65
Clean Class		---	Class10	---
Environment Requirements	Ambient Temperature	5 to 40°C		
	Humidity Range	5 to 90% (non-condensing)		
Weight		36 kg		
cULus Compliant		---		
Basic configuration	Controller	eMotionBlox-60R		
	On-board I/O (Input/Output)	12/8		
	Conveyor tracking input	2		
	RS-232C serial communications port	1		
	Programming environment	ACE, ePLC		
	ACE Sight	Yes		
	ePLC Connect	Yes		
	ePLC I/O	Yes		
Connectable controller *1		eMotionBlox-60R, SmartController EX, NJ/NX/NY Series *2		

\*1. Choose a controller to suit your application.

\*2. The robot version 2.3.C or later is required to connect with the NJ/NX/NY Series.

# Dimensions

(Unit: mm)

## Viper 850

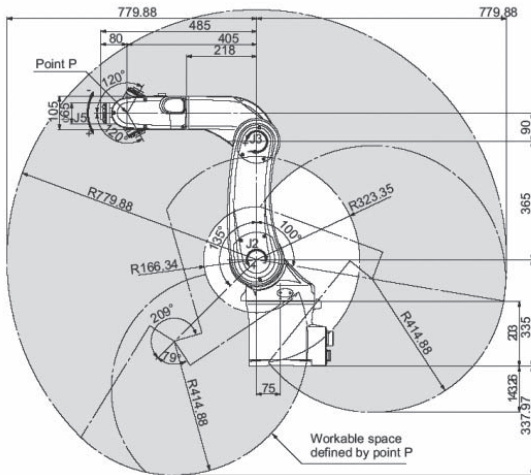

## eMotionBlox-60R

Weight : 9.3 kg

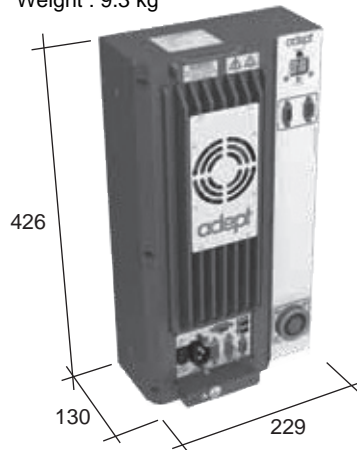

## Front panel



## Footprint

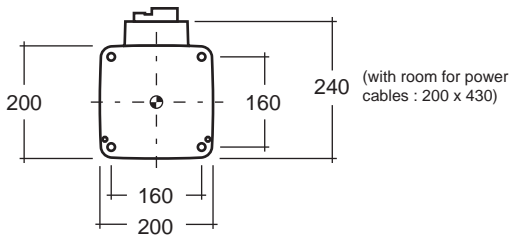

## Flange

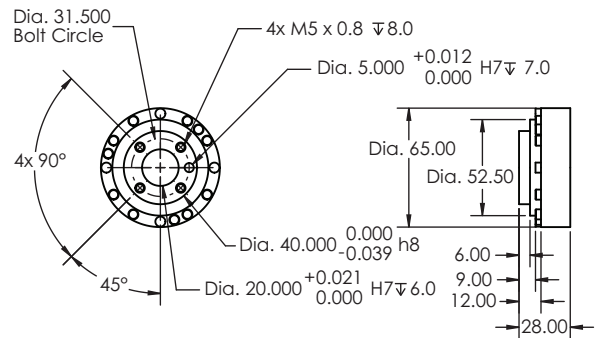

# Robot Parts Code and Bundled Accessories

Type	Viper			Viper Add-On			
	Cleanroom/IP	Standard	Cleanroom	IP54/65	Standard	Cleanroom	IP54/65
<b>Viper 850</b>		17201-38000	17201-38020	17201-38010	17203-38000	17203-38020	17203-38010
<b>Overview</b>	Robot + eMotionBlox-60R amplifier with fully integrated controls			Robot + eMotionBlox-60R + required connection cables			
<b>Purpose</b>	Typical for use in single robot system			Typically added to systems with an existing SmartController EX to create multi-robot systems			
<b>Bundled Accessories</b>	<ul style="list-style-type: none"> <li>XSYSTEM cable with jumpers, 1.8 m/6 ft (13323-000)</li> <li>Front panel kit (92546-10358)</li> <li>Arm power/signal cable, 4 m/13 ft                             <ul style="list-style-type: none"> <li>Standard Model: 05020-000</li> <li>Cleanroom &amp; IP54/65 Models: 05463-000</li> </ul> </li> </ul>			<ul style="list-style-type: none"> <li>XSYSTEM cable with jumpers, 1.8 m/6 ft (13323-000)</li> <li>XSYS cable, 4.5 m/15 ft (11585-000)</li> <li>DB9 splitter (00411-000)</li> <li>1394 latch cable, 4.5 m/15 ft (13632-045)</li> <li>eV+ license to connect to controller (14529-103)</li> </ul>			

# SmartController EX

## High-performance robot motion controller capable of high-speed processing

- Controls up to four robots
- Gigabit Ethernet
- 12 inputs/8 outputs
- Ultra-compact form factor for high footprint efficiency
- Integration with configuration software ACE to control complex mechanisms through user-friendly interface



## Specifications

Item	Specifications	
Part Number	19300-000	
Grounding Method	Ground to less than 10 Ω	
Dimensions (Height × Depth × Width)	86 × 187 × 329 mm	
Weight	2.6 kg	
Power Supply	24 VDC±10%	
Current Consumption	5 A	
Power Consumption	120 W	
Operation Environment	Ambient Temperature	5 to 40°C
	Humidity Range	5 to 90% (non-condensing)
Mounting	Panel mount, rack mount, stack mount, desktop	
Communications Port	RS-232 (115 kbps), RS422/485, Gigabit Ethernet, DeviceNet	
On-board I/O (Input/Output)	12/8	
Conveyor tracking input	4	

## Dimensions

(Unit: mm)

SmartController EX

Front panel



**Note:** Front Panel is provided with the SmartControllerEX.

## Additional I/O Options

---

### Input Specifications

Item	Specifications
Part Number	90356-30200/-30100/-40100
Rated Output Current	700 mA/point
Maximum Output Current	2.5 A at 50°C ambient 3.7 mA at 25°C ambient
ON Delay Time	100 $\mu$ s max.
OFF Delay Time	150 $\mu$ s max.

### Output Specifications

Item	Specifications
Part Number	90356-30200/-30100/-40100
ON Voltage	10 V min.
OFF Voltage	3 V max.
OFF Current	0.5 mA
Input Current	2.5 mA min. 7.5 mA max.
ON Delay Time	5 $\mu$ s max.
OFF Delay Time	5 $\mu$ s max.
Isolation Method	Photocoupler isolation
Current Consumption from I/O Power Supply	6 mA max. (at power supply voltage of 24 VDC)

# Automation Control Environment (ACE)

**ACE is a PC-based software package that easily manages Omron's entire portfolio of robots, controls, vision, and feeding systems**

ACE software provides an easy-to-use environment to program and deploy applications ranging from simple pick & place to multi-robot belt-tracking lines. It allows you to increase productivity while streamlining configuration setup. ACE 4.0 shifts to an even more intuitive interface and provides superior data visualization.



- Fast emulation and 3D visualization for quick proof of concept
- Wizard-based user-friendly interface to calibrate and teach the robots
- Recipe Manager simplifies management of manufacturing process and handles a range of product variations, ideal for flexible automation to reduce changeover time
- Robot Vision Manager enables vision guided conveyor-tracking and AnyFeeder integration via wizards
- Robot Vision Manager 4.0 also includes vision inspection tools to improve quality assurance and traceability

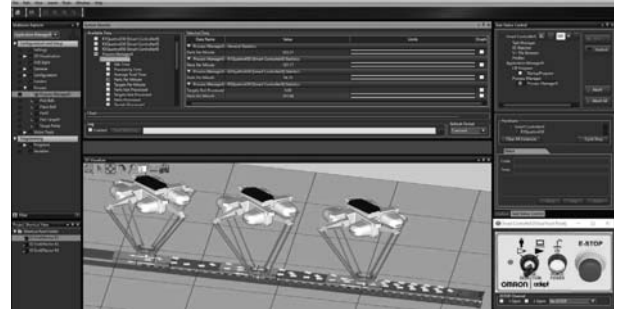

## Application Manager

ACE provides another layer of simplification for Application development, by means of the Application Manager modules. These modules enable advanced programming capabilities for Packaging (PackManager) and Vision (Robot Vision Manager) applications.

**PackManager** can manage scalable packaging lines from integration to deployment and step-by-step guidance without scripting. The software walks you through the configuration of packaging applications by setting up process-specific items, such as controllers, robots, and conveyor belts.

### Main Features:

- Process Manager optimizes the resources, decreasing idle time and maximizing the amount of parts processed per robot.
- Fully customizable for any line configuration and advanced load balancing.

**Scalable**  
Manage robots on packaging lines

**Versatile**  
No lengthy programming required

**Fast**  
Deploy your application faster through a user-friendly GUI

**Adaptable**  
Create your own operator interface with the built-in UI Builder

**Reusable**  
Use across a variety of applications

**Visual**  
Get a 3D view of your packaging line

**Complete**  
Adjust control settings through eV+ and C#

**Note:** When ACE PackManager is used to configure an application, robot cycle time may vary between the SmartController EX and eAIB/eMotionBox.

**Robot Vision Manager** provides algorithms and tools for easily integrated vision systems into robotic applications. Camera calibration, part identification, and image processing tools are supported as part of this manager.

Application Manager modules run as part of ACE and are executed on Omron's IPC Application Controller.

## ACE License Configuration

License	Part Number	Explanation
ACE PackManager (for ACE 4.x)	20409-000	Enables full functionality of the ACE PackManager software.
Robot Vision Manager (for ACE 4.x)	20410-000	Enables the Robot Vision Manager functionality and inspection tools library.
Dual (PackManager plus Vision)	20433-000	Enables functionality of both PackManager and Robot Vision Manager

**Note:** When you create robot programs without using PackManager wizards and vision system, the ACE license is not required.

## System Requirements

Item	Requirement
<b>Operating system (OS)</b>	Windows 7 (64-bit version) / Windows 10 (64-bit version)
<b>CPU</b>	Intel® Core™ i5 or equivalent or faster recommended.
<b>Main memory</b>	2 GB min. (8 GB recommended.)
<b>Video memory</b>	512 MB min.
<b>Hard disk</b>	At least 1 GB of available space
<b>Display</b>	XGA 1,024 × 768, 16 million colors. WXGA 1,280 × 800 min. recommended
<b>Communications ports</b>	USB port (for hardware key), Ethernet port
<b>Supported languages</b>	English, French, German, Japanese, Spanish, Italian, Korean, Simplified Chinese, Traditional Chinese

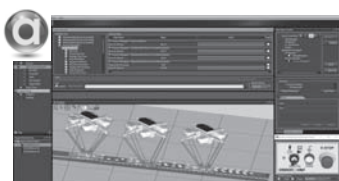

### Automation Control Environment (ACE)

ACE is a PC-based software package that helps you quickly and easily set up your robot system. ACE is available to download from the Omron website:  
<http://www.ia.omron.com/>

# ePLC Robot Control Library

## No need to learn a new robot programming language Control robots directly from the NJ/NX/NY Controller

- The same instructions and programming method can be used to control any type of robot: parallel, SCARA, or articulated robot
- Robots can be controlled by using Function Blocks in Ladder or ST language
- Data on robots, controller, and other devices can be integrated and visualized
- Robots are connected to the NJ/NX/NY Controller via EtherNet/IP. \*

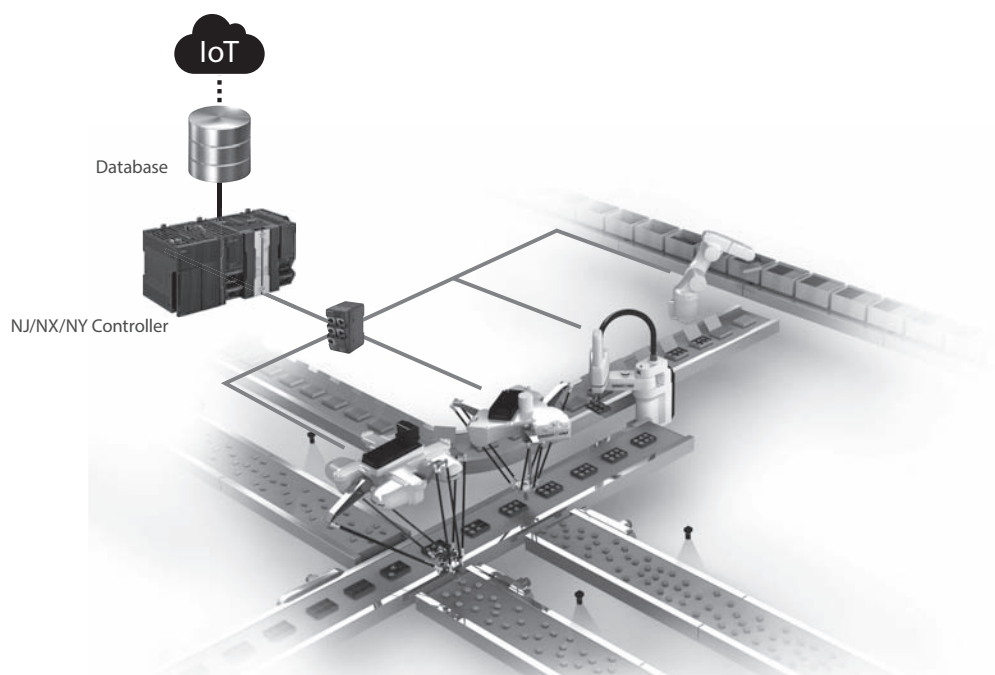

\* The communication cycle time between the robot and NJ/NX/NY Controller depends on the robot controller. When the SmartController EX is used, the communications cycle time is 15 times faster than when the eAIB or eMotionBlox is used.

## Function Block (FB) Specifications

Name	FB name	Description
Set Tool Trans	ARB_SetToolTransform	Sets a tool system transformation to the robot.
Reset Tool Transform	ARB_ResetToolTransform	Resets the robot tool which is set to the robot.
Define Location	ARB_DefineLocation	Defines a position in the robot.
Define Pallet	ARB_DefinePallet	Defines all pallet information in the robot.
Reset Error	ARB_ResetRobotError	Resets any existing error in the robot.
Robot Control	ARB_RobotControl	Controls the main robot settings and monitors the robot status.
Teach Position	ARB_TeachPosition	Teaches the current robot position and configuration.
Input Output Signals	ARB_InputOutputSignals	Communicates with the robot through its digital inputs and outputs.
Teach Pendant Control	ARB_TeachPendantControl	Sends and receives information from the manual control pendant attached to the robot.
Read Latch	ARB_ReadLatch	Outputs the current robot position when an external trigger is input.
Move	ARB_MoveCommand	Moves the robot to a target position using a linear interpolation or PTP operation.
Pick And Place	ARB_PickAndPlaceCommand	Moves the robot to a target position in a three-part motion.
Jog	ARB_Jog	Moves the specified joint or axis of the robot.
Align Tool Command	ARB_AlignToolCommand	Rotates the tool to be aligned with the world coordinate system.
Move Arc Command	ARB_MoveArcCommand	Moves the robot to the specified target position along arc trajectory.
Move Circular Command	ARB_MoveCircularCommand	Moves the robot along a circular trajectory, passing specified two positions.
Define Belt	ARB_DefineBelt	Defines a conveyor belt.
Belt Read Latch	ARB_BeltReadLatch	Outputs the belt encoder value of the conveyor when an external trigger is input.
Track Belt	ARB_TrackBelt	Enables tracking a workpiece.



## Compatible Part Numbers

Name		Part Number	Version
Adept Robot Control Library		SYSMAC-XR009	---
Machine Automation Controller NJ/NX CPU Unit		NX701-[ ][ ][ ][ ]/NJ101-[ ][ ][ ][ ]	Version 1.10 or later
		NJ501-[ ][ ][ ][ ]/NJ301-[ ][ ][ ][ ]	Version 1.01 or later
		NX1P2-[ ][ ][ ][ ][ ] (1)	Version 1.13 or later
Industrial PC Platform NY IPC Machine Controller		NY5[ ][ ]-1	Version 1.12 or later
Automation Software Sysmac Studio		SYSMAC-SE2[ ][ ][ ]	Version 1.15 or later
Parallel Robot	Hornet 565	1720[ ]-4560[ ]	Version 2.3.C or later
	Quattro 650H/HS, 800H/HS	1720[ ]-26[ ][ ][ ]	Version 2.3.C or later
SCARA Robot	eCobra 600/800	17[ ][ ][ ]-1[ ][ ][ ]00	Version 2.3.C or later
	Cobra 450/500/650	1720[ ]-1[ ][ ][ ]00	---
Articulated Robot	Viper 650/850	1720[ ]-36[ ][ ]000	Version 2.3.C or later



### Sysmac Library

The Sysmac Library is a collection of software functional components that can be used in programs for the NJ/NX/NY Controllers.

Please download it from following URL and install to Sysmac Studio Automation Software.

[http://www.ia.omron.com/sysmac\\_library/](http://www.ia.omron.com/sysmac_library/)

The Adept Robot Control Library allows you to control parallel, SCARA, and articulated robots manufactured by Omron Adept Technologies Inc. from the NJ/NX/NY Controllers by using the same instructions and programming methods.

# Robot Accessories



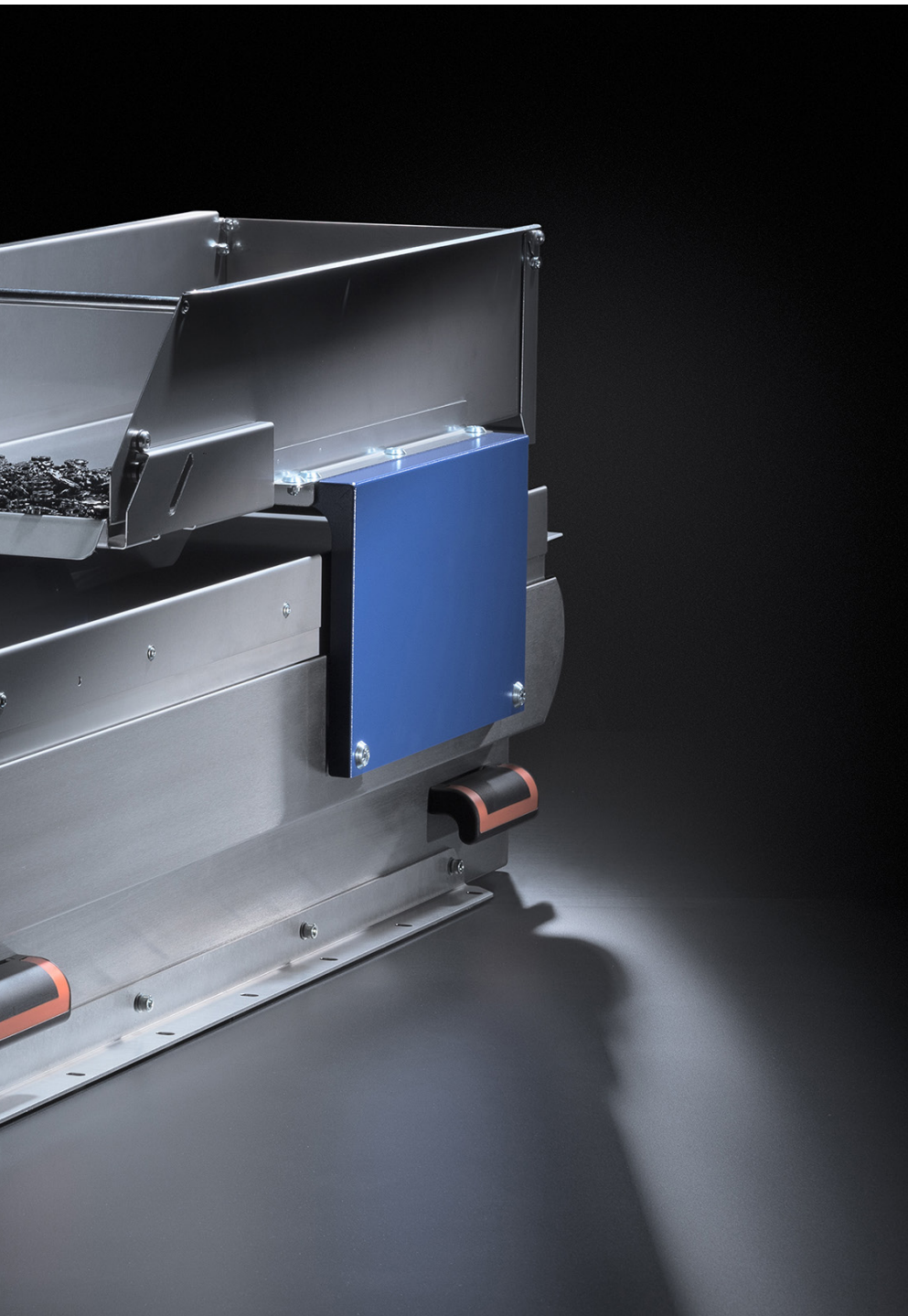

# IPC Application Controller

## State-of-the-art industrial computer optimized for vision guided robotics applications

- Built-in vision processor with 128GB SSD, optimized to process high resolution, high frame rate images, with ACE 4.X
- System configuration by PC, include Sysmac Studio
- Appear feature about Robot Vision Manager, PackManager and Recipe Manager
- Unique simplified thermal design to maximize uptime
- GigE PoE and USB 3.0 ports for increased connectivity and fast data-transmission
- Supports up to 8 cameras simultaneously
- Compatible with Omron UPS S8BA Series
- Compact design to minimize panel space, allowing 2 mounting orientations



## Specifications

Item		Specifications
Part Number		AC1-152000
Weight		3.8 kg
Grounding Method		Ground to less than 100 Ω
Dimensions (Height × Depth × Width)		89 × 200 × 282 mm
Main System	CPU	Intel® Core™ i5-7440EQ
	Main Memory	8 GB DDR4
	Trusted Platform Module	Available
	Graphics Controller	Intel® HD Graphics
	Watchdog	Yes
Operating System		Windows 10 IoT Enterprise LTSC - 64 bit
Storage Devices	Hard Drive	128 GB SSD Additional 3.5 inch hard drive slot available Additional SD memory card slot available, up to 32 GB capacity
Power Supply		20.4 to 28.8 VDC
Power Consumption		97.6 W (when using 2x USB 3.0 and 4x POE Cameras)
Communications Port	Power Connector	24 VDC
	I/O Connector	2 inputs (UPS signal and power OFF control) and 1 output (Industrial Box PC power state)
	Ethernet Connector	Gigabit Ethernet x 3, Gigabit Ethernet with POE x 4 3 W max power consumption per port
	USB	USB 3.0 x 4 (3 m max cable length), USB 2.0 x 2 (5 m max cable length)
	Display	DVI-Connector x 1 (up to 1,920 × 1,200 @60 Hz)
	RS-232C	Standard DSUB9 connector (Non-Isolated)
Battery	Part Number	CJ1W-BAT01
	Service Life	5 years at 25°C
Fan Unit	Part Number	NY000-AF00
	Service Life	70,000 hours of continuous operation at 40°C with 15% to 65% relative humidity
LED		PWR, ERR, HDD, RUN
Operation Environment	Ambient Temperature	0 to 55°C for operation, -20°C to 70°C for storage
	Humidity Range	10 to 90% (non-condensing)

# Dimensions

(Unit: mm)

## IPC Application Controller

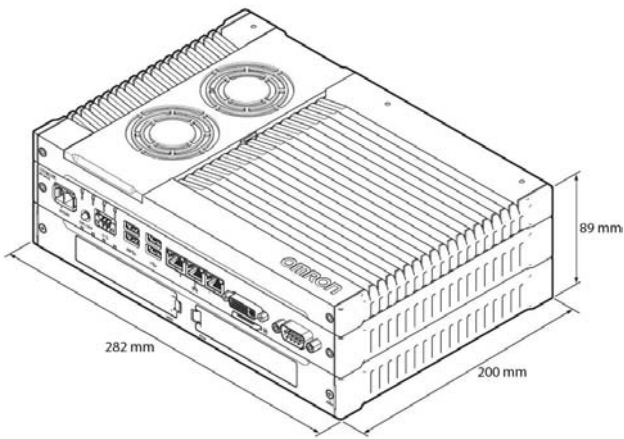

## Dongle



**Note:** The dongle is bundled with the ACE License, which is not included in the IPC bundle. Insert the dongle into the USB port of the IPC Application Controller.

## Bracket Dimensions

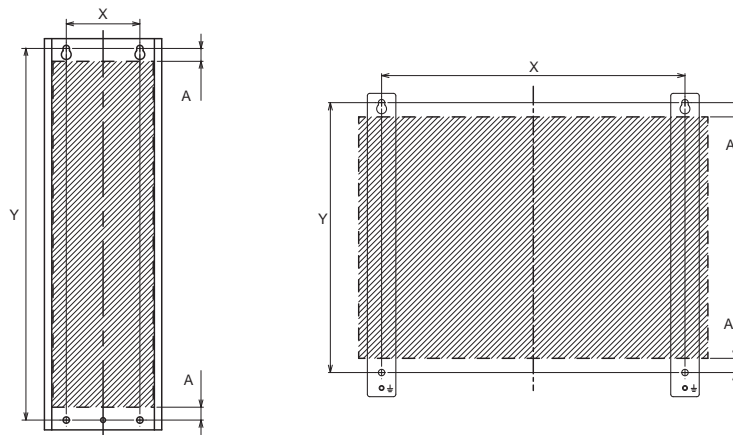

(Unit: mm)

Part Number	Bracket type	Drill Specifications			Product Dimensions	
		Hole Distance X	Hole Distance Y	Hole Distance A	Bracket Width	Bracket Height
NYB45-SPK	Book mount	60 mm	303 mm	11 mm	96 mm	319 mm
	Wall mount	245 mm	218 mm	12 mm	23 mm	245 mm

## System Configuration

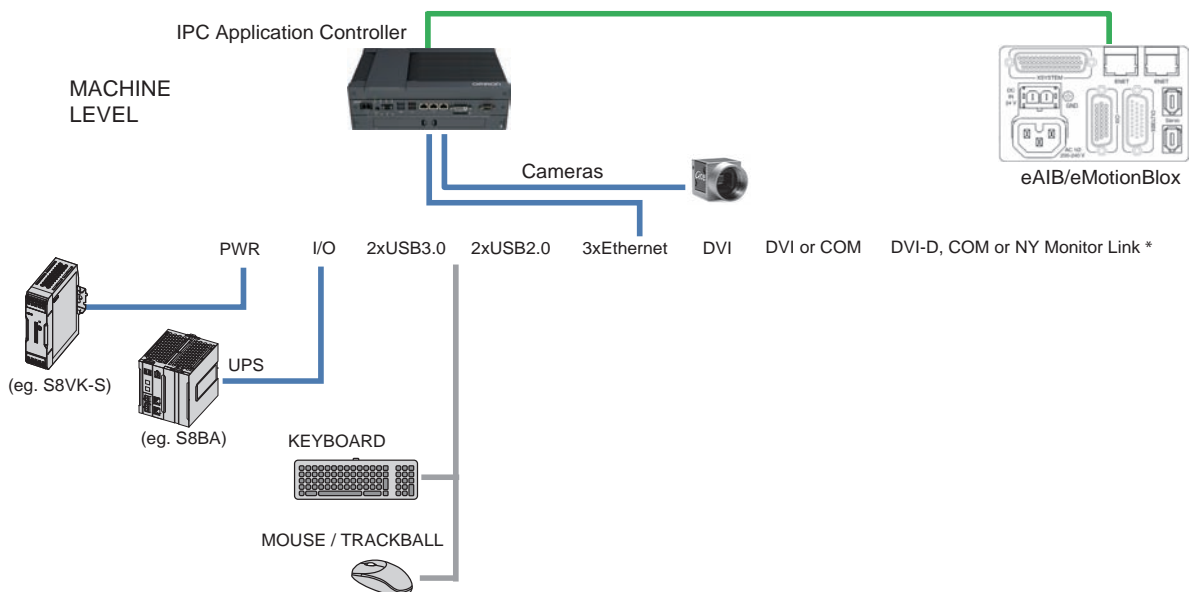

## Accessories

### Optional Hardware

Product name	Specifications	Part Number
Mounting Brackets	Book mount	NY000-AB00 NY000-AB04
	Wall mount	NY000-AB01
SD Memory Cards	Card type: SD Card Capacity: 2 GB Format: FAT16	HMC-SD292
	Card type: SDHC Card Capacity: 4 GB Format: FAT32	HMC-SD492
USB Flash Drives	Capacity: 2 GB	FZ-MEM2G
	Capacity: 16 GB	FZ-MEM16G
Storage Devices	Storage type: SSD, Capacity: 128 GB (same with default built in SSD)	NY000-AS04
USB Type-A to USB Type-B Cables	Cable length: 2 m USB 2.0 Minimum bend radius: 25 mm	FH-VUAB 2M
	Cable length: 5 m USB 2.0 Minimum bend radius: 25 mm	FH-VUAB 5M
DVI Cables	Cable length: 2 m Supports DVI-D Minimum bend radius: 36 mm	NY000-AC00 2M
	Cable length: 5 m Supports DVI-D Minimum bend radius: 36 mm	NY000-AC00 5M
Industrial Monitor	<ul style="list-style-type: none"> <li>• LCD touchscreen</li> <li>• Multi-touch functionality</li> <li>• Supply voltage: 24 VDC</li> <li>• Up to 1,280 x 800 pixels at 60 Hz</li> <li>• 2 USB Type-A Connectors</li> <li>• Programmable brightness control</li> <li>• Standard and 100 m cable part numbers are available.</li> </ul>	NYM1[ ] W-C10[ ][ ]
Power Supply	<ul style="list-style-type: none"> <li>• Output voltage: 24 VDC</li> <li>• Push-In Plus terminal blocks</li> </ul>	S8VK-S[ ][ ][ ] 24
UPS	Output voltage during backup operation: 24 VDC $\pm$ 5%	S8BA with revision number 04 or higher *1
UPS Communication Cable	Cable length: 2 m Signals for <ul style="list-style-type: none"> <li>• Signal output (BL, TR, BU, WB)</li> <li>• Remote ON/OFF input</li> <li>• UPS Stop Signal input (BS)</li> </ul>	S8BW-C02

\*1. Revision number 04 or higher. The revision number of the UPS can be retrieved from the serial number label on the product and the product packaging.

### Spare Parts

The following spare parts for the Industrial Box PC are available.

Product name	Specifications	Part Number
Battery	One battery is supplied with the Industrial Box PC. The battery supplies power to the real-time clock. The battery is located inside the Industrial Box PC. Service life: 5 years at 25°C	CJ1W-BAT01 *1
Fan Unit	The Fan Unit is available for the Industrial Box PC that has active cooling. Service life: 70,000 hours of continuous operation at 40°C with 15% to 65% relative humidity. Shelf life: 6 months This is the storage limitation with no power supplied.	NY000-AF00
Accessory Kit	Accessory Kit containing all accessories supplied with the Industrial Box PC. <ul style="list-style-type: none"> <li>• Power connector</li> <li>• I/O connector</li> <li>• Drive bracket for drive installation</li> <li>• 4 mounting screws for drive installation</li> <li>• PCIe Card support for PCIe Card installation</li> <li>• PCIe Card clip for PCIe Card installation</li> </ul>	NY000-AK00

\*1. Only for part numbers with replaceable battery.

## Electrical Specifications

Item	Specifications
Rated power supply voltage	24 VDC, non-isolated
Allowable power supply voltage range	20.4 to 28.8 VDC
Grounding method	Ground to less than 100 Ω
Inrush current	At 24 VDC: 12 A / 6 ms max. for cold start at room temperature
Overvoltage category	JIS B3502 and IEC 61131-2: Category II
EMC immunity level	IEC 61131-2: Zone B
RTC accuracy	At ambient temperature of 55°C: -3.5 to +0.5 min error per month At ambient temperature of 25°C: -1.5 to +1.5 min error per month At ambient temperature of 0°C: -3 to +1 min error per month
Power button life	100,000 operations
Battery life	5 years at 25°C (for battery CJ1W-BAT01)
Fan life	8 years of continuous operation at 40°C
Power consumption *	–
Drives	–
SSD iMLC 128 GB	0.8 W
Expansions	–
USB	14 W max. ((2 x 500 mA at 5 V) + (2 x 900 mA at 5 V))
POE	3 W max.

**Note:** Refer to the *IPC Application Controller User's Manual (I632)* for detail.

\* The total power consumption is the sum of the power consumption of all items that are installed in your Industrial Box PC.

To guarantee S8BA UPS operation in combination with our IPC, the specified combination of UPS and power-supply must be used.

Item	Minimum power requirements	
Power supply	240 W	120 W
UPS	120 W	120 W

## Environmental Specifications

Item	Specifications	
Operation environment	Ambient operating temperature *1	0 to 55°C
	Ambient storage temperature *1	-20 to 70°C
	Ambient operating humidity *1	10% to 90% with no condensation
	Ambient storage humidity *1	10% to 90% with no condensation
	Operating atmosphere	No corrosive gases
	Altitude	2,000 m max.
	Noise resistance (during operation)	Conforms to IEC61000-4-4, 2 kV (power lines)
	Vibration resistance (during operation)	Conforms to IEC 60068-2-6. For a product with an SSD: 5 to 8.4 Hz with 3.5 mm single amplitude and 8.4 to 150 Hz with 9.8 m/s <sup>2</sup> for 10 times each in X, Y and Z directions. For a product with a HDD the vibration resistance depends on the mounting orientation *2.
	Shock resistance (during operation)	Conforms to IEC 60068-2-27. 147 m/s <sup>2</sup> , 3 times in each X, Y and Z directions
	Installation method	Book mount, Wall mount
Pollution degree	2 or less: Conforms to JIS B3502 and IEC 61131-2.	
Applicable standards *3	EU Directives: EMC Directive 2014/30/EU (EN 61131-2) and RoHS Directive RCM, EAC	

\*1. The allowed ambient operating temperature and ambient humidity depend on product type, CPU type, mounting orientation, and storage device type.

\*2. Vibration resistance depends on the IPC Application Controller's mounting orientation and storage device type:

Mounting orientation	SSD
Book	9.8 m/s <sup>2</sup>
Wall	

\*3. Refer to the OMRON website ([www.ia.omron.com](http://www.ia.omron.com)) or contact your OMRON representative for the most recent applicable standards for each part number.

# 3D Pick Manager Solution

## Fully integrated 3D part picking solution using Photoneo 3D PhoXi Scanners and easy-to-use 3D Pick Manager

- Click-through sample application wizard quickly guides the user through part & bin setup, camera settings, and picking sequence.
- 3D Pick Manager + Calibration kit includes all the hardware and software necessary to get up and running for 3D pick applications on the Viper robot.
- Available on Viper 650/850 stand-alone robot series
- High-quality Photoneo PhoXi 3D Scanner support fully integrated into the ACE software platform
- Easily upload part CAD files or use simply geometry to teach target parts
- 3D Pick Manager bundles include:
  - Photoneo PhoXi 3D Scanner
  - PoE Cable + Power Injector
  - Ethercat Cable (From PoE to IPC)
- 3D Scanner Calibration kit includes all hardware necessary to teach the robot position relative to the 3D scanner



## Specifications

Product name	3D Pick Manager			
	Size	Small	Medium	Large
	Cleanroom/IP	IP65		
Part Number		21857-100	21857-200	21857-300
Scanning Range		384-520 mm	458-1118 mm	870-2150 mm
Optimal Scanning Distance (Sweet Spot)		442 mm	650 mm	1239 mm
Scanning Area (At Sweet Spot)		360 x 286 mm	590 x 421 mm	1082 x 802 mm
Point to Point Distance		0.174	0.286	0.524
Calibration Accuracy		0.05	0.1	0.2
Temporal Noise		0.05	0.1	0.19
Scanning Time		250-2250 ms	250 - 2500 ms	250 - 2750 ms
Dimensions		77 x 68 x 296 mm	77 x 68 x 416 mm	77 x 68 x 616 mm
Baseline		230 mm	450 mm	550 mm
Weight		900 g	950 g	1100 g
Projection Angle		74.55°	78.25°	80.55°



# Dimensions

(Unit: mm)

## PhoXi 3D Scanner Small

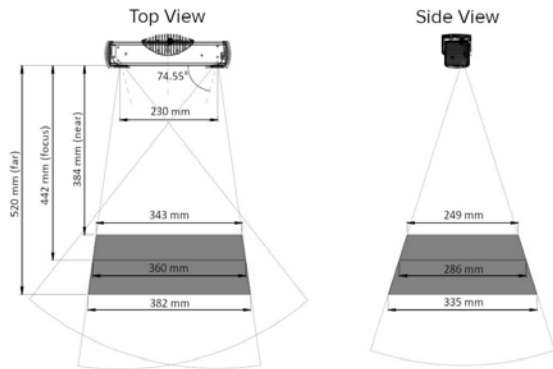

## PhoXi 3D Scanner Medium

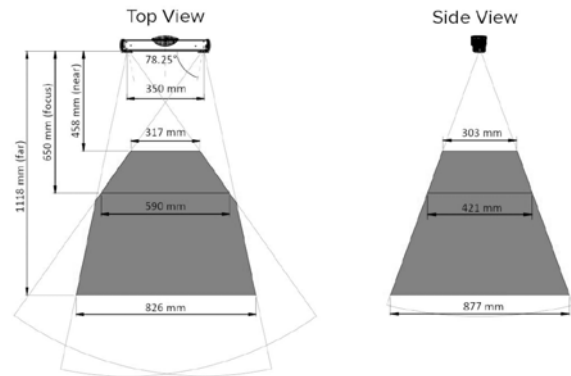

## PhoXi 3D Scanner Large

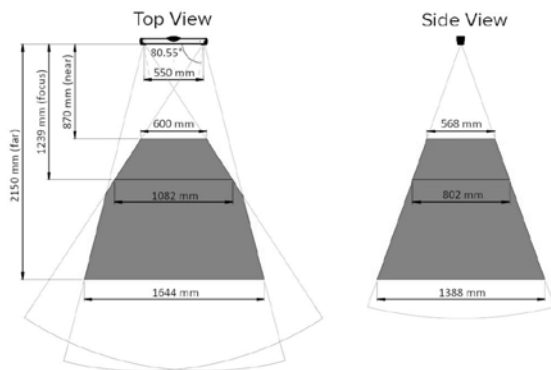

## Additional Accessories

Type	Calibration Kit
Part Number	21857-900
Overview	Calibration kit is necessary to calibrate the robot arm position to the 3D Scanner
Required Accessories	An IPC Application Manager (pn: AC1-152000) is required to run the 3D Pick Manager SW and be connected directly to the 3D Scanner

# Industrial Cameras

## Industrial cameras for complete Robot Vision integration.

- High performance industrial cameras that seamlessly communicate with robots and the control environment.
- Cameras include the latest CMOS sensor technology for use in automated processes.
- Well-suited to a wide range of robotics applications with high image quality, high frame rates, and compact design.
- Compatible with all 35+ powerful tools in the Automation Control Environment (ACE) Software for vision guidance and inspection.



Basler



Sentech

## Ordering Information

Manufacturer	Part Number	Pixels (HxV)	Shutter	
Sentech	STC-MBS43POE	720 x 540	Global	
	STC-MCS43POE			
	STC-MBE132POE	1280 x 1024		
	STC-MCE132POE			
	STC-MBS163POE	1440 x 1088		
	STC-MCS163POE			
	STC-MBS202POE	1626 x 1240		
	STC-MCS202POE			
	STC-MBS312POE	2048 x 1536		
	STC-MCS312POE			
	STC-MBS500POE	2448 x 2048		
	STC-MCS500POE			
	STC-MBA503POE-HS	2592 x 1944		Rolling
	STC-MCA503POE-HS			
STC-MBS1242POE	4000 x 3000			
STC-MCS1242POE				
Basler *	24114-250 *	1602 x 1202	Rolling/Global	
	24114-251 *	1600 x 1200		
	24114-300 *	2048 x 2048	Global	
	24114-301 *	2046 x 2046		

\* The Omron, Basler part numbers include the following bundled accessories: tripod mount, 10 m Ethernet cable, and 10 m power I/O cable.

## Accessories

Item	Camera Compatibility	Description	Part Number
Power I/O cable	Basler models	10 m Power-I/O Cable with HRS 6p connector and open end.	09454-610
Cat6 Camera Cable	Basler models	10 m GigE Cat6 cable with RJ45 plug and Mod RJ45 with Horizontal Screw Lock connector.	18472-000
Camera Tripod Mount	Basler models	Adapter plate for attaching camera to user-supplied tripod.	14308-000
Power I/O cable	Sentech models	10 m Power-I/O Cable with HR10A-7P connector and open end.	21942-000
Cat5e Camera Cable	Sentech models	10 m GigE CAT5e cable with RJ45 plug and Mod RJ45 with Horizontal Screw Lock connector.	21943-000
Camera Tripod Mount	Sentech Models	Adapter plate for attaching camera to user-supplied tripod.	21941-000

# Specifications

## Sentech Camera Specifications

Part Number	STC-MBS43POE/ STC-MCS43POE	STC-MBE132POE/ STC-MCE132POE	STC-MBS163POE/ STC-MCS163POE	STC-MBS202POE/ STC-MCS202POE	STC-MBS312POE/ STC-MCS312POE	STC-MBS500POE/ STC-MBCS500POE	STC-MBA503POE-HS/ STC-MCA503- POE-HS	STC-MBS1242POE/ STC-MCS1242POE
Image Sensor	IMX287	EV76C560	IMX273	IMX430	IMX265	MX264	AR0521	IMX226
Sensor Size (in)	1/2.9	1/1.8	1/2.9	1/1.7	1/1.8	2/3	1/2.5	1/1.7
Cell Size (µm)	6.9 x 6.9	5.3 x 5.3	3.45 x 3.45	4.5 x 4.5	3.45 x 3.45	3.45 x 3.45	2.2 x 2.2	1.85 x 1.85
Exposure Time	1 µs to 16.777 seconds (Default: 3,425 µs)	10 µs to 1.0300 seconds (Default: 16,379 µs)	1 µs to 16.777 seconds (Default: 13,936 µs)	1 µs to 16.777 seconds (Default: 18,166 µs)	1 µs to 16.777 seconds (Default: 28,404 µs)	1 µs to 16.777 seconds (Default: 45,345 µs)	20.2 µs to 1.323 seconds (Default: 45,696.9 µs)	213 µs to 16.777 seconds (Default: 107,488 µs)
Interface	PoE: IEEE802.3af CLASS2 (1000BASE-T)							
Protocol	GigE Vision 2.1 and GenICam SFNC 2.4, IEEE1588 (PTP)							
I/O	One opto-isolated input, one opto-isolated output, and one open collector GPIO (input or output)							
Power Input Voltage *1	+10.8 to +26.4 VDC external power (via power/IO connector) / Power Over Ethernet (IEEE802.3af)							
Power Consumption	+12 V / +24 V: 3.7 W / PoE: 4.7 W	+12 V / +24 V: 3.1 W / PoE: 3.7 W	+12 V / +24 V: 3.7 W / PoE: 4.7 W	+12 V / +24 V: 4.0 W / PoE: 4.9 W	+12 V / +24 V: 3.5 W / PoE: 4.4 W	+12 V / +24 V: 3.6 W / PoE: 4.4 W	+12 V / +24 V: 3.0 W / PoE: 3.6 W	+12 V / +24 V: 3.4 W / PoE: 4.1 W
Dimensions *2	29 (W) x 29 (H) x 53 (D) mm							
Lens Mount	C Mount							
Interface Connectors	Ethernet connector: RJ45 connector; Power/IO connector: HR10A-7R-6PB (Hirose) or equivalent							
Weight	65 g	63 g	65 g	65 g	65 g	65 g	62 g	65 g
Minimum Operational Temperature/ Humidity	0°C / 20% RH non-condensing							
Maximum Operational Temperature/ Humidity *3	+39°C / 85% RH non-condensing	+35°C / 85% RH non-condensing	+39°C / 85% RH non-condensing	+36°C / 85% RH non-condensing	+39°C / 85% RH non-condensing	+40°C / 85% RH non-condensing	+36°C / 85% RH non-condensing	+40°C / 85% RH non-condensing
Storage Temperature/ Humidity	-20 – 70°C, 20 – 85% RH non-condensing	-20 – 75°C, 20 – 85% RH non-condensing	-20 – 70°C, 20 – 85% RH non-condensing	-20 – 70°C, 20 – 85% RH non-condensing	-20 – 70°C, 20 – 85% RH non-condensing	-20 – 70°C, 20 – 85% RH non-condensing	-20 – 70°C, 20 – 85% RH non-condensing	-20 – 70°C, 20 – 85% RH non-condensing
Vibration	20 Hz to 200 Hz to 20 Hz (5 min. / cycle), acceleration 10 G, XYZ 3 directions, 30 min. each							
Shock	Acceleration 38 G, half amplitude 6 ms, XYZ 3 directions, 3 times each							
Standard Compliancy	EMS: EN61000-6-2, EMI: EN55011							
RoHS	RoHS Compliant							

- \*1. When an external power supply and Power over Ethernet (PoE) are both supplied to the camera at the same time, the camera defaults to the external power supply.
- \*2. Dimensions exclude the connectors at the rear of the camera.
- \*3. Ensure the camera is installed with the appropriate heat dissipation. A mounted lens and a tripod with an aluminum plate can decrease the camera housing temperature for heat dissipation. When the internal temperature sensor on the camera shows less than 65°C, the camera housing temperature (top plate) will be less than 57°C.

## Basler Camera Specifications

Part Number	24114-250	24114-251	24114-300	24114-301
Image Sensor	EV76C570		CMV4000	
Sensor Size	1/1.8		1	
Cell Size (µm)	4.5 x 4.5		5.5 x 5.5	
Exposure Time	10/35 µs (global/rolling) - 840000 µs		24 µs - 10000000 µs	
Interface	Fast Ethernet (100 Mbit/s) Gigabit Ethernet (1000 Mbit/s)			
Protocol	GigEVision 1.x, SFNC 1.x			
I/O	1 Opto-coupled input line and 1 Opto-coupled output line			
Power Input Voltage	12 VDC (10.8 VDC minimum, 13.2 VDC maximum), includes <1% ripple.			
Power Consumption	PoE: 2.7 W / 12 VDC: 2.1 W		PoE: 3.1 W / 12 VDC: 2.6 W	
Dimensions *1	42.0 x 29 x 29 CS Mount / 54.0 x 29 x 29 C Mount			
Lens Mount	C Mount	C mount / CS mount	C Mount	C Mount
Interface Connectors	Ethernet connector: RJ45 connector; Power/IO connector: HR10A-7R-6PB (Hirose) or equivalent			
Weight	<90 g			
Minimum Operational Temperature/ Humidity	0°C / 20%, RH non-condensing			
Maximum Operational Temperature/ Humidity	50°C / 80%, RH non-condensing			
Storage Temperature/Humidity	-20–80°C / 20–80%, RH non-condensing			
Vibration	Sine (each axis): 10–58 Hz / 1.5 mm; 58–500 Hz / 20 g; 1 Octave/Minute, 10 repetitions / Random (each axis): 15-500 Hz / 0.05 PSD (ESS standard profile) / 00:30 h			
Shock	20 g / 11 ms / 100 shocks positive; 20 g / 11 ms / 100 shocks negative			
Standard Compliancy	CE, EAC, UL Listed, FCC, GenICam, GigE Vision, IP30, IEEE 802.3af (PoE), REACH, KC			
RoHS	RoHS Compliant			

\*1. Dimensions exclude the connectors at the rear of the camera.

# Camera Dimensions

(Unit: mm unless otherwise noted)

## Sentech Models

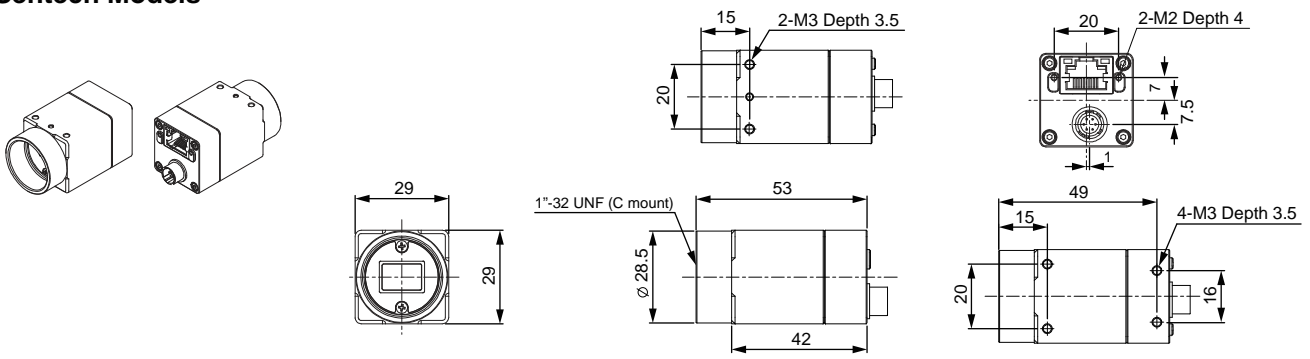

## Basler Models

(C Mount Models)

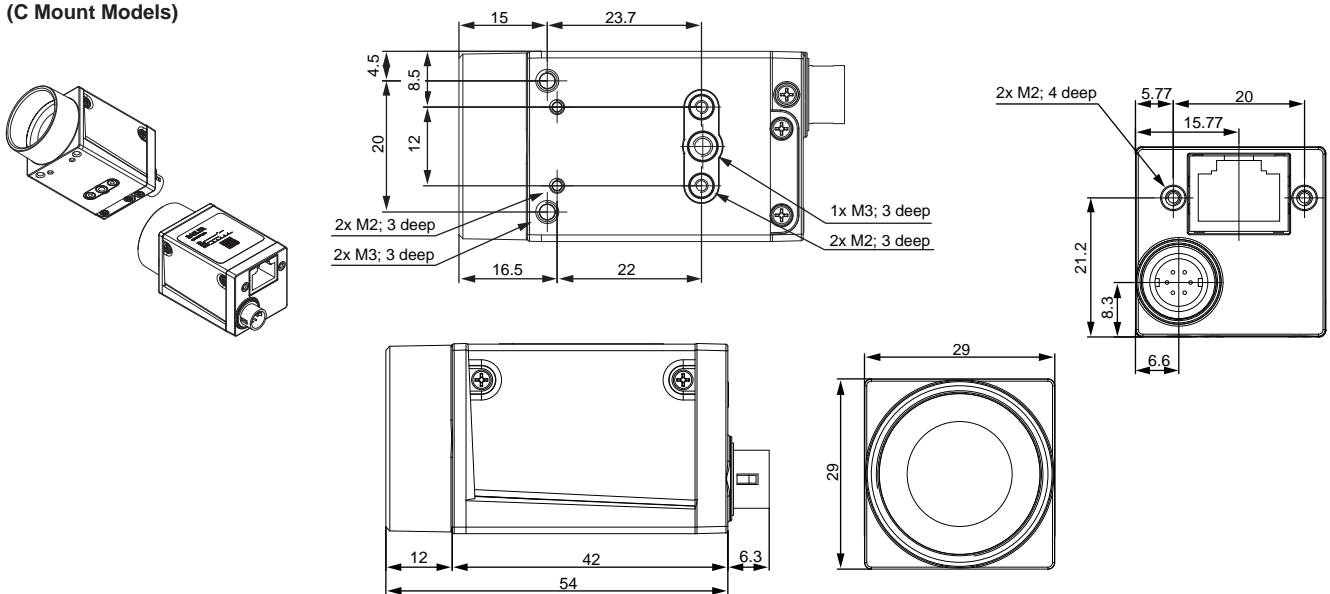

(CS Mount Models)

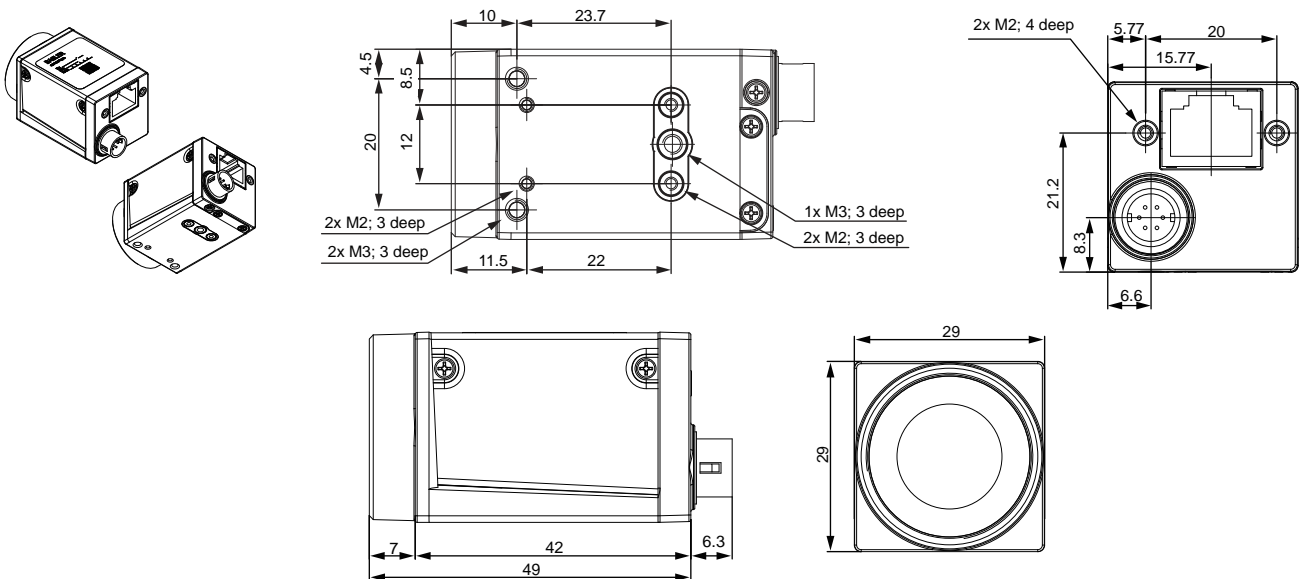

# Camera Connections

## Sentech Connections

Ethernet connector (RJ-45 connector)<sup>1</sup>

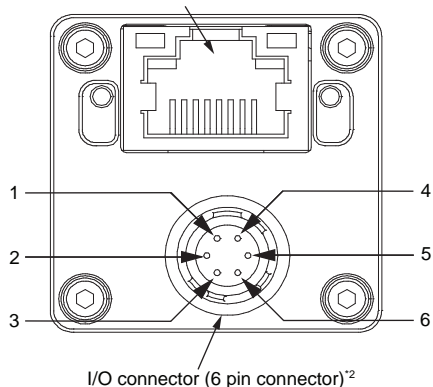

Pin	Description
1	Power IN (+10.8 to +26.4 VDC)
2	Opto isolated IN (Line 0)
3	Open Collector GPIO (Line 2)
4	Opto isolated OUT (Line 1) Open Collector
5	Opto isolated Common
6	Ground

## Basler Connections

Ethernet connector (RJ-45 connector)<sup>1</sup>

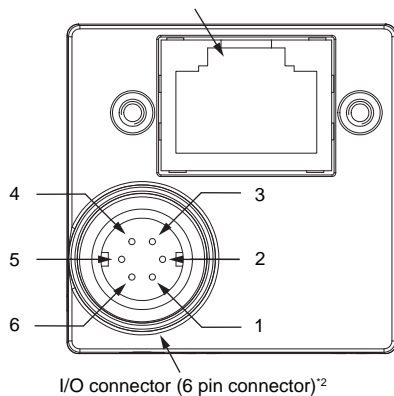

Pin	Description
1	Camera Power (+12 VDC)
2	Opto IN 1
3	No Connection
4	Opto OUT 1
5	Opto I/O Ground
6	Camera Power (0 VDC)

- \*1. Supply power to the camera via Power over Ethernet (PoE) or with a power supply and I/O cable. A PoE NIC or Ethernet switch is needed to supply power via PoE.
- \*2. Connect all cables according to the specifications prescribed in the camera's documentation.

## Related Manuals

Document Number	Manual Title	Description
I667	Robot Vision Manager User's Manual	Provides information necessary for understanding the integration of cameras and V+ programs.
I633	Automation Control Environment (ACE) Version 4 User's Manual	Instruction for the use of the ACE Version 4 software.
I679	Automation Control Environment (ACE) Version 4 Camera Configuration User's Manual	Provides information on configuring cameras for use with the ACE software.
ST101	Sentech Product Specifications and User's Guide	Provides product information and specifications and part numbers for Sentech cameras.

- Note:** 1. Refer to the Basler website for Basler camera documentation.  
2. Refer to the OMRON website for Sentech camera documentation.

# Pendant T20 Pendant

## Excellent operability and ergonomic design

- Tested for a 1.5 meter drop onto industrial flooring
- Displays custom messages
- Emergency stop switch (dual channel circuit)
- Enable switch on back
- Bright display with backlight and contrast adjustment



## Dimensions

(Unit: mm)

### T20 Pendant



## Wall Bracket Dimensions - Optional

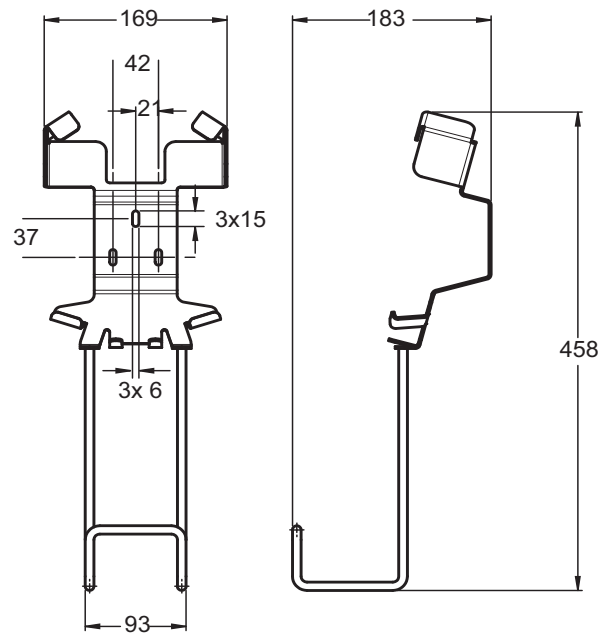



## Connection to SmartController

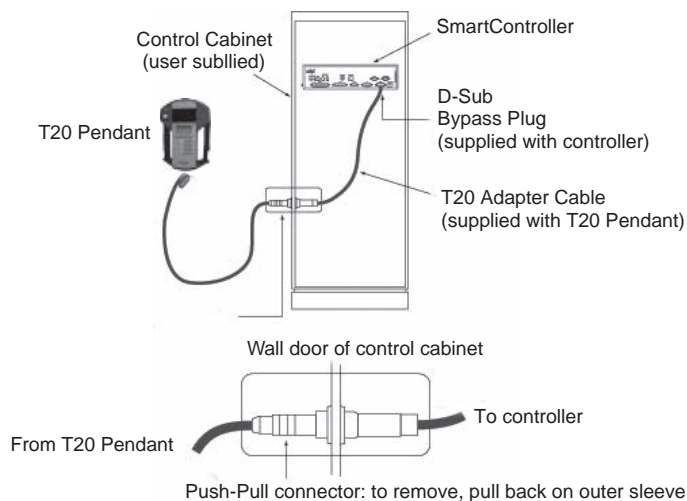

## Panel and Front Panel Installation

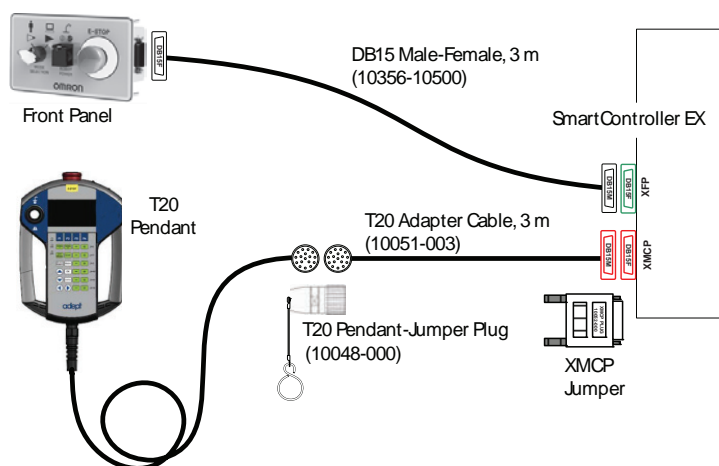

Name	Details	Part Number
Pendant	T20 Pendant, 10 m Cable	10046-010
	T20 Pendant-Jumper Plug	10048-000
	T20 Pendant Wall Bracket	10079-000
	T20 Adapter Cable, 3 m	10051-003

## Recommended FlexFactory Product

# AnyFeeder

## Feeding bulk parts for alignment and assembly

- Flip, forward, and backward for easy pickup by robot in combination with vision
- Pickup after flipping parts to identify front or rear
- Easy configuration of AnyFeeder, vision, and robots using wizards
- Flexible feeding of various parts registered in Recipe Manager in ACE or Sysmac
- Available with all part numbers of SCARA, articulated, and parallel robots



## Ordering Information

Product Name		SXM-100	SXM-140
FlexFactory Part Number		900-001-161	900-001-162
Omron Part Number		09725-500 *	18819-500 *
Alternative part numbers with integrated backlight	IR	09725-501 *	18819-501 *
	Red	09725-502 *	18819-502 *
Field of Vision		100 x 134 mm	140 x 193 mm
Suitable for Parts	Material	Metal, Plastic, Glass (Stable)	Metal, Plastic, Glass (Stable)
	Main dimensions	< 30 mm	< 45 mm
	Thickness	> 0.15 mm	> 0.15 mm
	Weight	< 15 g	< 25 g
Maximum Weight in Field of Vision		500 g	500 g
Connections	Electrical	1	1
	Pneumatic	-	-
	Serial	1	1
Weight		18 kg	22 kg
Power Requirements		24 VDC 10 A	24 VDC 10 A
Typical Power Usage		100 W (usage dependent)	100 W (usage dependent)
Air Requirements		-	-
Drivers		2 brushless servomotors 130 W	2 brushless servomotors 130 W
Data interface		RS232 (D-SUB 9 connector)	RS232 (D-SUB 9 connector)
Environmental Requirements	Temperature	5 - 45°C	5 - 45°C
	Humidity	5 - 90% (non-condensing)	5 - 90% (non-condensing)
Materials of construction: Main unit, Bulk Container, Feeder platform and surface border		Stainless Steel 1.4301 (304)	Stainless Steel 1.4301 (304)
Bulk storage capacity		3 kg	5 kg

Product Name		SX-240	SX-340
FlexFactory Part Number		900-001-164	900-001-165
Omron Part Number		12480-500 *	14269-500 *
Alternative part numbers with integrated backlight	IR	12480-501 *	14269-501 *
	Red	12480-502 *	14269-502 *
Field of Vision		240 x 320 mm	340 x 453 mm
Suitable for Parts	Material	Metal, Plastic, Glass (Stable)	Metal, Plastic, Glass (Stable)
	Main dimensions	< 75 mm	< 110 mm
	Thickness	> 0.5 mm	> 0.5 mm
	Weight	< 60 g	< 80 g
Maximum Weight in Field of Vision		1500 g	1500 g
Connections	Electrical	1	1
	Pneumatic	1	1
	Serial	1	1
Weight		50 kg / 110 lb	55 kg / 121 lb
Power Requirements		24 VDC 10 A	24 VDC 10 A
Typical Power Usage		100 W (usage dependent)	100 W (usage dependent)
Air Requirements		6 bar / 87 psi, compressed air, filtered, unlubricated	6 bar / 87 psi, compressed air, filtered, unlubricated
Drivers		2 brushless servomotors 130 W	2 brushless servomotors 130 W
Data interface		RS232 (D-SUB 9 connector)	RS232 (D-SUB 9 connector)
Environmental Requirements	Temperature	5 - 45°C	5 - 45°C
	Humidity	5 - 90% (non-condensing)	5 - 90% (non-condensing)
Materials of construction: Main unit, Bulk Container, Feeder platform and surface border		Stainless Steel 1.4301 (304)	Stainless Steel 1.4301 (304)
Bulk storage capacity		10 kg	12 kg

\* Power Cable, AnyFeeder, 5 m and RS232 Cable, AnyFeeder, 4.5 m are provided with the AnyFeeder.

# Dimensions

(Unit: mm)

SXM-100

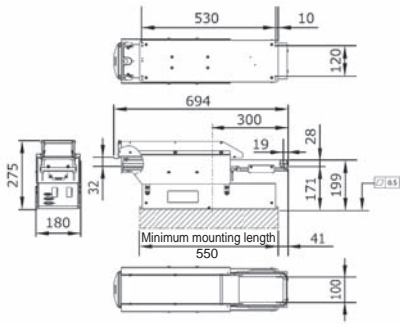

SXM-140

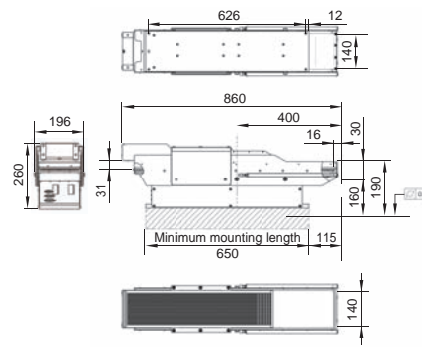

SX-240

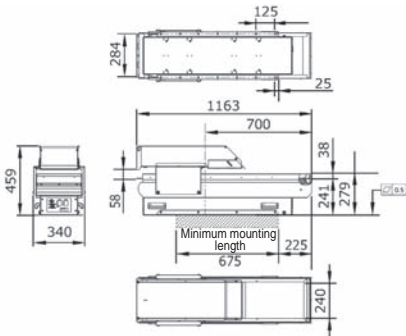

SX-340

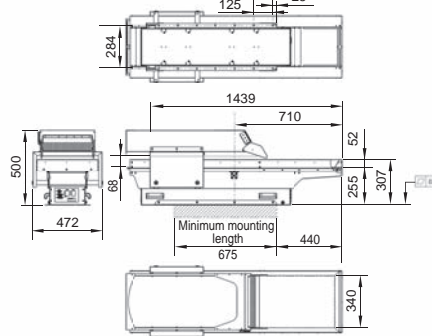

# Options

Type	Name/Specifications	FlexFactory Part Numbers	Omron Part Numbers
Backlight	Backlight - IR 875 nm, SXM100	900-000-072	09725-202
	Backlight - Red 630 nm, SXM100	900-000-367	09725-201
	Backlight - IR 875 nm, SXM140	900-000-215	14630-000
	Backlight - Red 630 nm, SXM140	900-000-346	14630-001
	Backlight - IR 875 nm, SX240	900-000-158	05284-208
	Backlight - Red 630 nm, SX240	900-000-238	05284-206
	Backlight - IR 875 nm, SX340	900-000-235	14269-001
	Backlight - Red 630 nm, SX340	900-000-373	14269-002
Surface	Surface, POM-C, Flat, Light Brown, ESD, SXM100	007-001-679	09725-104
	Surface, POM-C, Flat, Black, SXM100 (Not available with backlight)	003-562-000	09725-102
	Surface, POM-C, Flat, Black, ESD, SXM100 (Not available with backlight)	007-001-357	09725-103
	Surface, POM-C, Flat, White, SXM100	002-290-000	09725-101
	Surface, POM-C, Flat, Light Brown, ESD, SXM140	007-001-012	09725-303
	Surface, POM-C, Flat, Black, SXM140 (Not available with backlight)	004-931-000	09725-302
	Surface, POM-C, Flat, White, SXM140	003-965-100	09725-301
	Surface, PVC, Flat, Light Gray, SXM140 (Not available with backlight)	007-001-359	09725-304
	Surface, POM-C Flat, Light Brown, ESD, SX240	007-001-046	05284-103
	Surface, POM-C, Flat, Black, SX240 (Not available with backlight)	001-821-000	05284-102
	Surface, POM-C, Flat, Black, ESD, SX240 (Not available with backlight)	007-001-794	05284-104
	Surface, POM-C, Flat, White, SX240	001-820-000	05284-101
	Surface, PVC, Flat, Gray, SX240 (Not available with backlight)	005-434-000	05284-105
	Surface, POM-C Flat, Light Brown, ESD, SX340	007-001-791	14269-005
	Surface, POM-C, Flat, Black, SX340 (Not available with backlight)	005-386-000	14269-004
Surface, PVC, Flat, Light Gray, SX340 (Not available with backlight)	007-001-295	14269-006	
Surface, POM-C, Flat, White, SX340	004-439-000	14269-003	
Others	ESD Option, SX240	-	05284-204
	Filter, Daylight, M27 x 5	-	09324-000

# Recommended JR3 Product Force Sensor

## Extending robot capabilities for advanced tactile applications

- Measurement of forces and moments in all three axes
- Digital output connected directly to robot controller
- Interaction with ACE (eV+) by means of commands and modes of operation
- Compatible with eCobra Standard and Pro, Viper, Hornet, and Quattro robots



## Ordering Information

Item		Specifications
JR3 Part Number		67M25A3
Omron Part Number		Go to Options table
Outer Diameter		67 mm
Thickness		25 mm
Body Material		AL 2024
Weight		175 g
Nominal Accuracy (All axes)		±1.0%
Operating Temperature		-40 to 65°C
Protection		IP40
F <sub>x</sub> and F <sub>y</sub> Constants	Standard Measurement Range	±200 N
	Digital Resolution	0.050 N
	Single-axis Overload	930 N
F <sub>z</sub> Constants	Standard Measurement Range	±400 N
	Digital Resolution	0.100 N
	Single-axis Overload	3870 N
M <sub>x</sub> and M <sub>y</sub> Constants	Standard Measurement Range	±12 N·m
	Digital Resolution	0.0032 N·m
	Single-axis Overload	58 N·m
M <sub>z</sub> Constants	Standard Measurement Range	±12 N·m
	Digital Resolution	0.0032 N·m
	Single-axis Overload	48 N·m
Operating Voltage		9 to 12 VDC
Sample Rate		8,000 Hz
Sensor Output Port		RJ-11

## Dimensions

(Unit: mm)

Sensor, Inner/Outer Adapter for eCobra/Hornet/Quattro

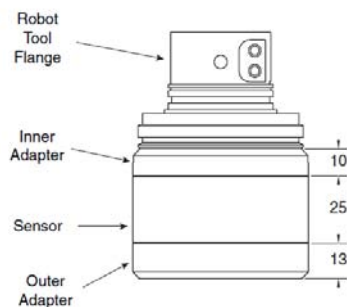

Sensor, Inner/Outer Adapter for Viper

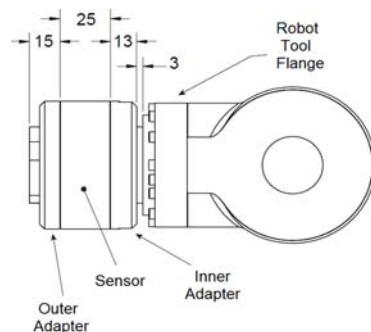

Outer adapters have the same hole and thread pattern as robot tool flanges.

## Options

Type	Kit, Intelligent Force Sensing, mounting and cabling	Kit, Sensor mounting and cabling (No sensor)
eCobra 600/800/800 inverted	14161-100	14161-105
Viper 650/850	14161-200	14161-205
Hornet 565 and Quattro 650/800	14161-300	14161-305
<b>Overview</b>	Force sensor, with mounting adapters, flanges, and cabling per robot type	Mounting adapters, flange, and cabling. No sensor included
<b>Purpose</b>	Complete installation kit for a customer without a force sensor	Kit for customers who have an existing JR3 67M25A3 force sensor, and require spares or adapters for another robot type
<b>Common Cables/Accessories</b>	Triplex Cable (DB9 M to eAIB or eMB-60R XBELTIO) Adapter Plate (inner) Adapter Plate (outer) Intelligent Force Sensing User's Guide	
<b>Cobra, Hornet and Quattro only Cables</b>	Upper Cobra Cable (RJ11 6-pin to DB25M) Lower Cobra Cable (Robot base to Triplex EXPIO - DB25F - DB9)	
<b>Viper only Cables</b>	Upper Viper Cable (RJ11 6-pin to CN21) Lower Viper Cable (CN20 to Triplex EXPIO- DB9 F)	

# Options/Accessories

## Options/Accessories

Type	Name/Specifications	Part Number
Robot Controller	SmartController EX with Front Panel	19300-000
	SmartController EX (without Front Panel)	19200-000
Pendant	T20 Pendant with 10 m Cable	10046-010
	T20 Pendant-Jumper Plug	10048-000
	T20 Pendant Wall Bracket	10079-000
	T20 Adapter Cable, 3 m	10051-003
Vision Controllers	IPC Application Controller	AC1-152000
	SmartVision MX	14189-901
Camera	Kit, Camera, GigE, POE, 720 x 540, 282.2 fps, B/W, M Series, 10 m camera cables included	31940-010
	Kit, Camera, GigE, POE, 720 x 540, 282.2 fps, Color, M Series, 10 m camera cables included	31940-011
	Kit, Camera, GigE, POE, 1280 x 1024, 61 fps, B/W, M Series, 10 m camera cables included	31940-130
	Kit, Camera, GigE, POE, 1280 x 1024, 61 fps, Color, M Series, 10 m camera cables included	31940-131
	Kit, Camera, GigE, POE, 1440 x 1088, 70.7 fps, B/W, M Series, 10 m camera cables included	31940-160
	Kit, Camera, GigE, POE, 1440 x 1088, 70.7 fps, Color, M Series, 10 m camera cables included	31940-161
	Kit, Camera, GigE, POE, 1624 x 1240, 54.6 fps, B/W, M Series, 10 m camera cables included	31940-200
	Kit, Camera, GigE, POE, 1624 x 1240, 54.6 fps, Color, M Series, 10 m camera cables included	31940-201
	Kit, Camera, GigE, POE, 2048 x 1536, 34.9 fps, B/W, M Series, 10 m camera cables included	31940-320
	Kit, Camera, GigE, POE, 2048 x 1536, 34.9 fps, Color, M Series, 10 m camera cables included	31940-321
	Kit, Camera, GigE, POE, 2448 x 2048, 21.9 fps, B/W, M Series, 10 m camera cables included	31940-500
	Kit, Camera, GigE, POE, 2448 x 2048, 21.9 fps, Color, M Series, 10 m camera cables included	31940-501
	Kit, Camera, GigE, POE, 2592 x 1944, 14 fps, B/W, M Series, 10 m camera cables included	31940-530
	Kit, Camera, GigE, POE, 2592 x 1944, 14 fps, Color, M Series, 10 m camera cables included	31940-531
	Kit, Camera, GigE, POE, 3856 x 2764, 10.3 fps, B/W, M Series, 10 m camera cables included	31940-100
	Kit, Camera, GigE, POE, 4000 x 3000, 9.2 fps, B/W, M Series, 10 m camera cables included	31940-120
	Kit, Camera, GigE, POE, 4000 x 3000, 9.2 fps, Color, M Series, 10 m camera cables included	31940-121
	GigE PoE, 1602 x 1202 pixels, 60 fps, Monochrome, CMOS (1/1.8-inch equivalent), 10 m camera cables included	24114-250
	GigE PoE, 1600 x 1200 pixels, 60 fps, Color, CMOS (1/1.8-inch equivalent), 10 m camera cables included	24114-251
	GigE PoE, 2048 x 2048 pixels, 25 fps, Monochrome, CMOS (1-inch equivalent), 10 m camera cables included	24114-300
GigE PoE, 2046 x 2046 dots, 25 fps, Color, CMOS (1-inch equivalent), 10 m camera cables included	24114-301	

Type	Name/Specifications	Part Number
Belt Encoder (Conveyor-Tracking)	Encoder Kit IP65	09742-001
	Y-Adapter Cable, 3 m	09443-000
	Encoder Extension Cable, 5 m	09446-050
	SCEX-BELT,Y-Adapter Cable, 0.5 m	09550-000
	XBELTIO Cable, 0.6 m	13463-000
Additional I/O Options	IO Blox (connect to robot), 8 inputs/8 outputs, 0.3 m cables included	90356-30200
	IO Block (connect to previous IO Blox), 8 inputs/8 outputs, 0.3 m cables included	90356-30100
	IO Blox-to-robot Cable, 3 m	04677-030
	IO Blox-to-IO Blox Cable, 0.3 m	04679-003
	IO Blox-to-IO Blox Cable, 3 m	04679-030
	XIO Termination Block, 12inputs/8 outputs, cables included (1.8 m)	90356-40100
	XDIO Termination Block, 50 pin, cables included (2m)	09747-000
Front panel	Front Panel Cable, 3 m	92546-10358
Power Supply/Cable	AC Power Cable, 5 m	04118-000
	24 VDC Power Cable, 5 m	04120-000
	24 VDC, 6.5 A, 150 W (Front Mounting), Power Supply	S8FS-G15024C
	24 VDC, 6.5 A, 150 W (DIN-Rail Mounting), Power Supply	S8FS-G15024CD
	1394 Cable, 4.5 m	13632-045
	XSYSTEM Cable Assembly, 1.8 m	13323-000
	XSYSTEM Cable Assembly (with ENET management port), 1.8 m	13323-100
	XIO Breakout Cable	04465-000
	DB9 Splitter, 0.3 m	00411-000
	eAIB XSYS Cable, 4.5 m	11585-000
	Ethernet Cable	XS6W-6LSZH8SS[ ][ ]CM-Y
Industrial Switching Hubs	W4S1-05D	
Solenoid Valve Kit	eCobra robots	02853-000
Cable Seal Kit	Hornet 565 IP65/67, Quattro 650HS IP65/67, Quattro 800HS IP65/67	08765-000
	Quattro 650HS Standard/Quattro 800HS Standard	09564-000
	eCobra 800 IP65/67	04813-000
	eCobra 800 Inverted IP65	09073-000
i4 Specific Accessories	Bracket, Wall Mount	20089-000
	Plate, eCobra Adapter (Allows i4H to be mounting with eCobra mount hole pattern)	21636-000
	Camera Bracket Mount	18908-000
	Solenoid Valve Kit	19165-000
Software Licenses	Automation Control Environment (for ACE 4.x)	Please download it from following URL: <a href="https://robotics.omron.com/browse-documents/?dir_id=8">https://robotics.omron.com/browse-documents/?dir_id=8</a>
	ACE PackManager (for ACE 4.x and Sysmac Studio 1.2x)	20409-000
	Robot Vision Manager (for ACE 4.x and Sysmac Studio 1.2x)	20410-000
	ACE PackManager with ACE Robot Vision Manager (for ACE 4.x and Sysmac Studio 1.2x) This license contains an ACE PackManager license and an ACE Robot Vision Manager license.	20433-000
	Sysmac Studio Standard Edition Version 1.xx	SYSMAC-SE201L
	Sysmac Studio 3D Simulation Option	SYSMAC-SA401L-64

# Installation Diagrams



















# Conveyor Tracking Robot System by SCEX

Control by SCEX with IPC Application Controller (When using a vision system)

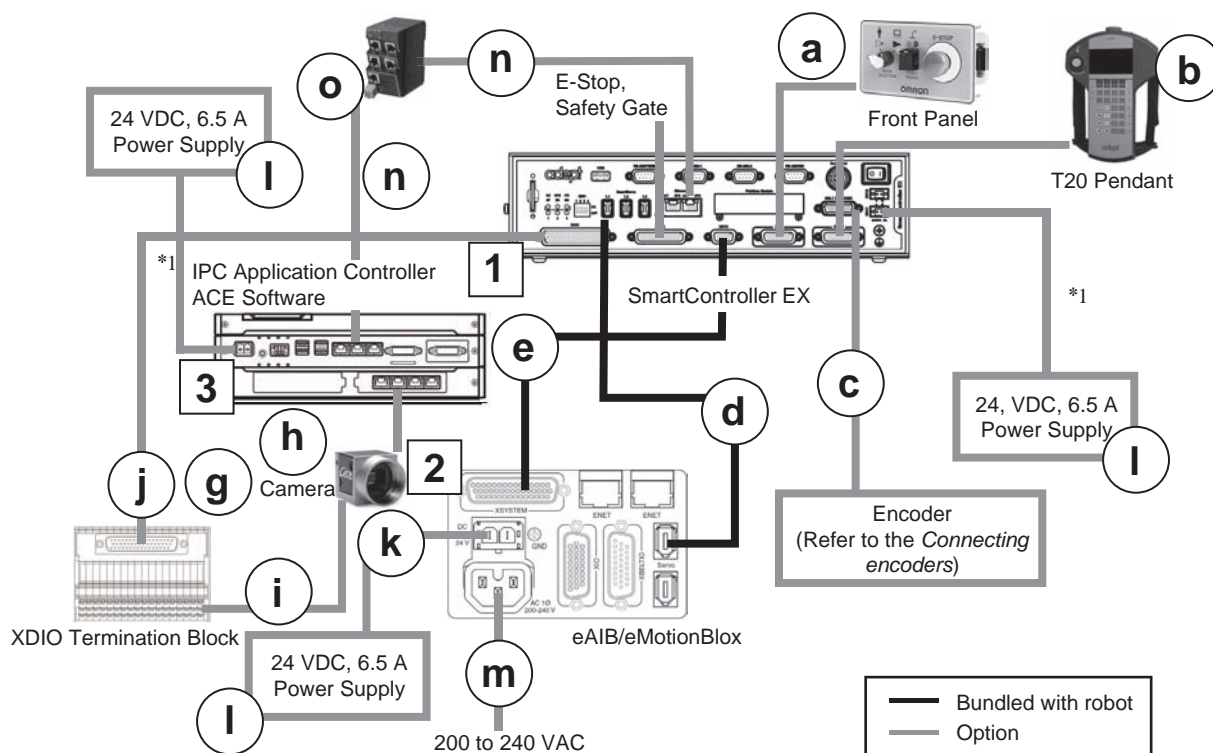

## eCobra, Viper, Hornet

Part	Name	Part Number	Note	Qty
1	SmartController EX	19300-000		1
a	Front Panel with Cable	92546-10358	Bundled with SmartController EX	(1)
b	T20 Pendant with Cable	10046-010		1
c	SCEX-BELT, Y-Adapter Cable	09550-000		1
2	Robot Add on	17[ ][3-[ ][ ][ ]]		1
d	IEEE 1394 Cable	13632-045	Bundled with Robot Add on	(1)
e	eAIB XSYS Cable	11585-000	Bundled with Robot Add on	(1)
3	IPC Application Controller	AC1-152000	Bundling a 24 VDC connector	1
g	Camera	319[ ][ ]-[ ][ ][ ]]		1*2
h	Camera Ethernet Cable	---	Bundled with Camera	1*2
i	Camera IO Cable	---	Bundled with Camera	1*2
j	XDIO Cable	09747-000	Bundled with XDIO Termination Block	1
k	24 VDC Power Cable	04120-000	Cable connector bundled with Robot	1
l	24 VDC, 6.5 A Power Supply	S8FS-G15024C or S8FS-G15024D		3
m	AC Power Cable	04118-000	Cable connector bundled with Robot	1
n	Ethernet Cable	XS6W-6LSZH8SS [ ][ ][ ]CM-Y		2
o	Industrial Switching Hubs	W4S1-05D		1
---	ACE PackManager with Robot Vision Manager License	20433-000	Included with Dongle	1

\*1. User-supplied shielded power cable.

\*2. Qty depends on system.

## Quattro

Part	Name	Part Number	Note	Qty
2	Robot	17214-2[ ][ ][ ]]		1
1	SmartController EX	09200-000	Bundled with Robot	(1)
a	Front Panel with Cable	92546-10358	Bundled with Robot	(1)
d	IEEE 1394 Cable	13632-045	Bundled with Robot	(1)
e	eAIB XSYS Cable	11585-000	Bundled with Robot	(1)
b	T20 Pendant with Cable	10046-010		1
c	SCEX-BELT, Y-Adapter Cable	09550-000		1
3	IPC Application Controller	AC1-152000	Bundling a 24 VDC connector	1
g	Camera	319[ ][ ]-[ ][ ][ ]]		1*2
h	Camera Ethernet Cable	---	Bundled with Camera	1*2
i	Camera IO Cable	---	Bundled with Camera	1*2
j	XDIO Cable	09747-000	Bundled with XDIO Termination Block	1
k	24 VDC Power Cable	04120-000		1
l	24 VDC, 6.5 A Power Supply	S8FS-G15024C or S8FS-G15024D		3
m	AC Power Cable	04118-000		1
n	Ethernet Cable	XS6W-6LSZH8SS [ ][ ][ ]CM-Y		2
o	Industrial Switching Hubs	W4S1-05D		1
---	ACE PackManager with Robot Vision Manager License	20433-000	Included with Dongle	1

\*1. User-supplied shielded power cable.

\*2. Qty depends on system.



# Conveyor Tracking Dual-Robot System

2 robots controlled by SCEX with IPC Application Controller (When using a vision system)

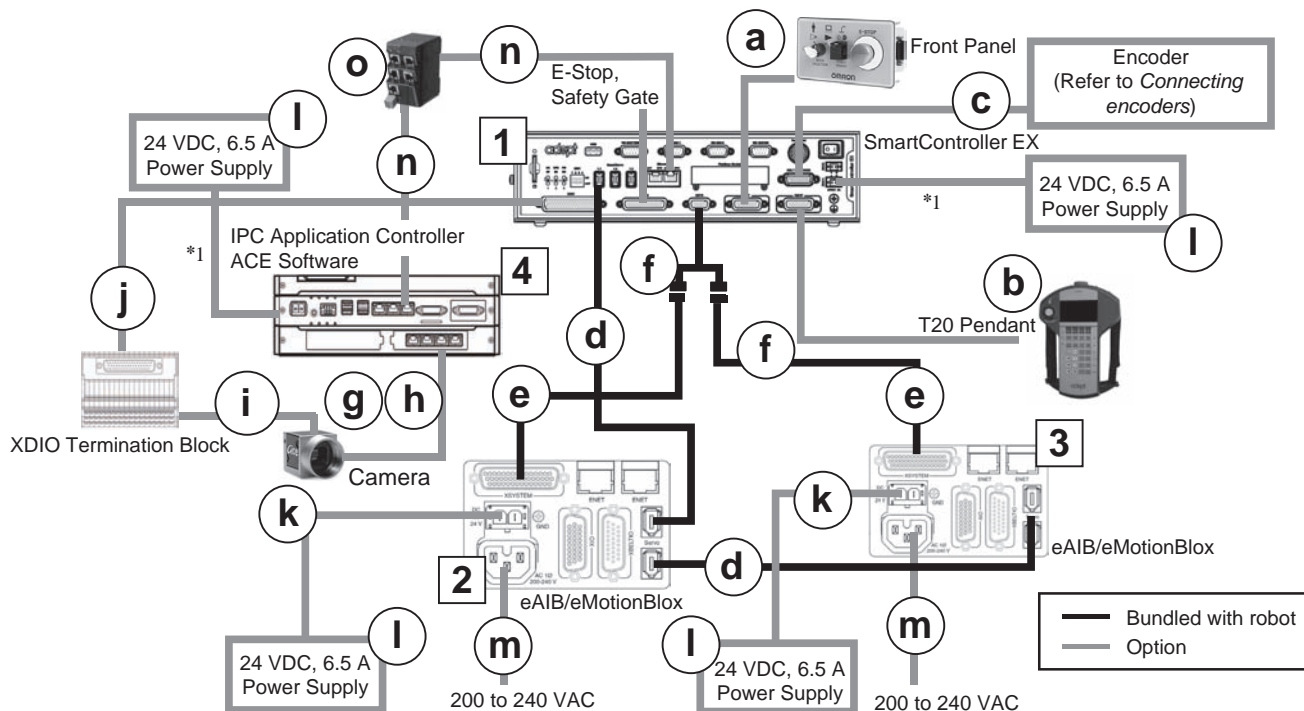

## eCobra, Viper, Hornet

Part	Name	Part Number	Note	Qty
1	SmartController EX	19300-000		1
a	Front Panel with Cable	92546-10358	Bundled with SmartController EX	(1)
b	T20 Pendant with Cable	10046-010		1
c	SCEX-BELT, Y-Adapter Cable	09550-000		1
2, 3	Robot Add on	17[ ][ ]3-[ ][ ][ ][ ]		2
d	IEEE 1394 cable	13632-045	Bundled with Robot Add on	(2)
e	eAIB XSYS Cable	11585-000	Bundled with Robot Add on	(2)
f	DB9 splitter	00411-000	Bundled with Robot Add on	(2)
4	IPC Application Controller	AC1-152000	Bundling a 24 VDC connector	1
g	Camera	319[ ][ ]-[ ][ ][ ]		1 *2
h	Camera Ethernet Cable	---	Bundled with Camera	1 *2
i	Camera IO Cable	---	Bundled with Camera	1 *2
j	XDIO Cable	09747-000	Bundled with XDIO Termination Block	1
k	24 VDC Power Cable	04120-000	Cable connectors bundled with Robots	2
l	24 VDC, 6.5 A Power Supply	S8FS-G15024C or S8FS-G15024D		4
m	AC Power Cable	04118-000	Cable connectors bundled with Robots	2
n	Ethernet Cable	XS6W-6LSZH8SS[ ][ ][ ] CM-Y		2
o	Industrial Switching Hubs	W4S1-05D		1
---	ACE PackManager with Robot Vision Manager License	20433-000	Included with Dongle	1

\*1. User-supplied shielded power cable.

\*2. Qty depends on system.

## Quattro

Part	Name	Part Number	Note	Qty
2	Robot	17214-2[ ][ ][ ]		1
1	SmartController EX	09200-000	Bundled with Robot	(1)
a	Front Panel with Cable	92546-10358	Bundled with Robot	(1)
d	IEEE 1394 cable	13632-045	Bundled with Robot	(1)
e	eAIB XSYS Cable	11585-000	Bundled with Robot	(1)
b	T20 Pendant with Cable	10046-010		1
c	SCEX-BELT, Y-Adapter Cable	09550-000		1
3	Robot Add on	17203-2[ ][ ][ ]		1
d	IEEE 1394 cable	13632-045	Bundled with Robot Add on	(1)
e	eAIB XSYS Cable	11585-000	Bundled with Robot Add on	(1)
f	DB9 splitter	00411-000	Bundled with Robot Add on	(1)
4	IPC Application Controller	AC1-152000	Bundling a 24 VDC connector	1
g	Camera	319[ ][ ]-[ ][ ][ ]		1 *2
h	Camera Ethernet Cable	---	Bundled with Camera	1 *2
i	Camera IO Cable	---	Bundled with Camera	1 *2
j	XDIO Cable	09747-000	Bundled with XDIO Termination Block	1
k	24 VDC Power Cable	04120-000		2
l	24 VDC, 6.5 A Power Supply	S8FS-G15024C or S8FS-G15024D		4
m	AC Power Cable	04118-000		2
n	Ethernet Cable	XS6W-6LSZH8SS[ ][ ][ ]		2
o	Industrial Switching Hubs	W4S1-05D		1
---	ACE PackManager with Robot Vision Manager License	20433-000	Included with Dongle	1

\*1. User-supplied shielded power cable.

\*2. Qty depends on system.

# Connecting encoders

## SmartController EX

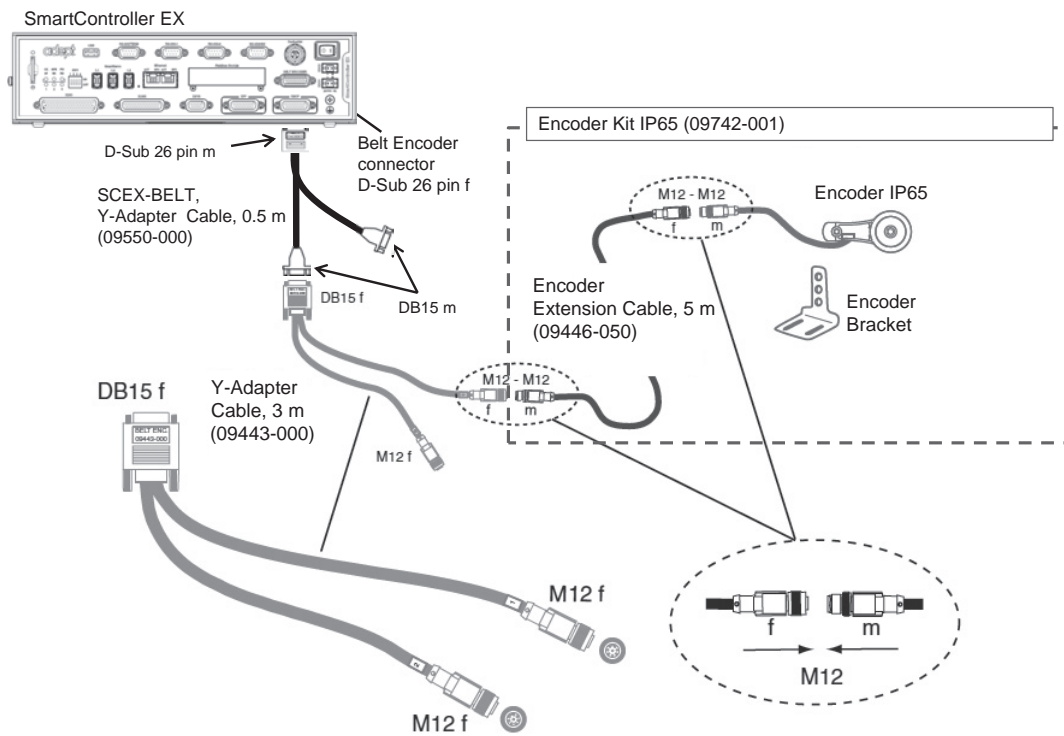

## eAIB/eMotionBlox/iCS

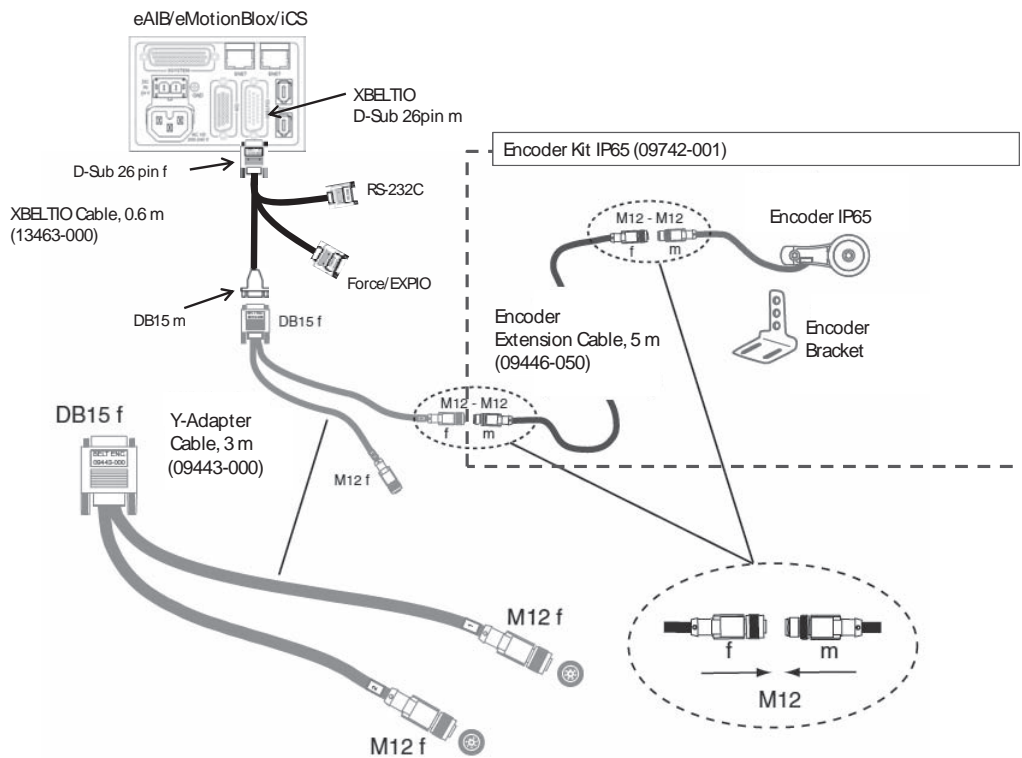

# Connecting additional I/O options

## Connecting IO Blox (8 inputs, 8 outputs) to increase I/O ports

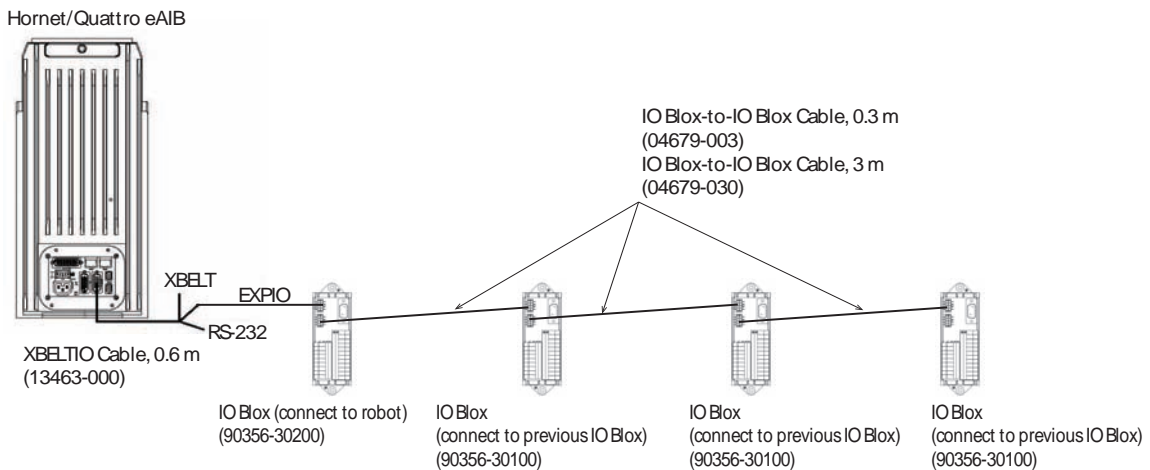
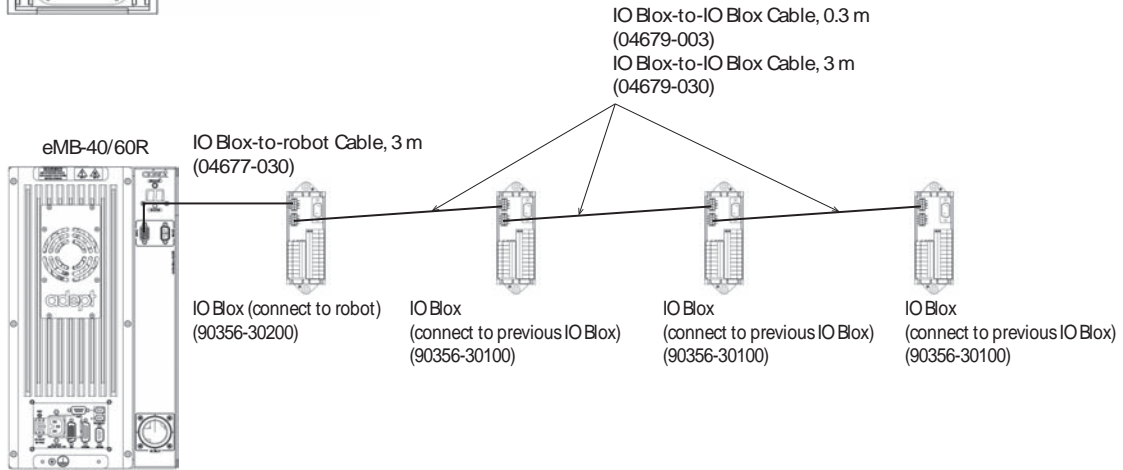
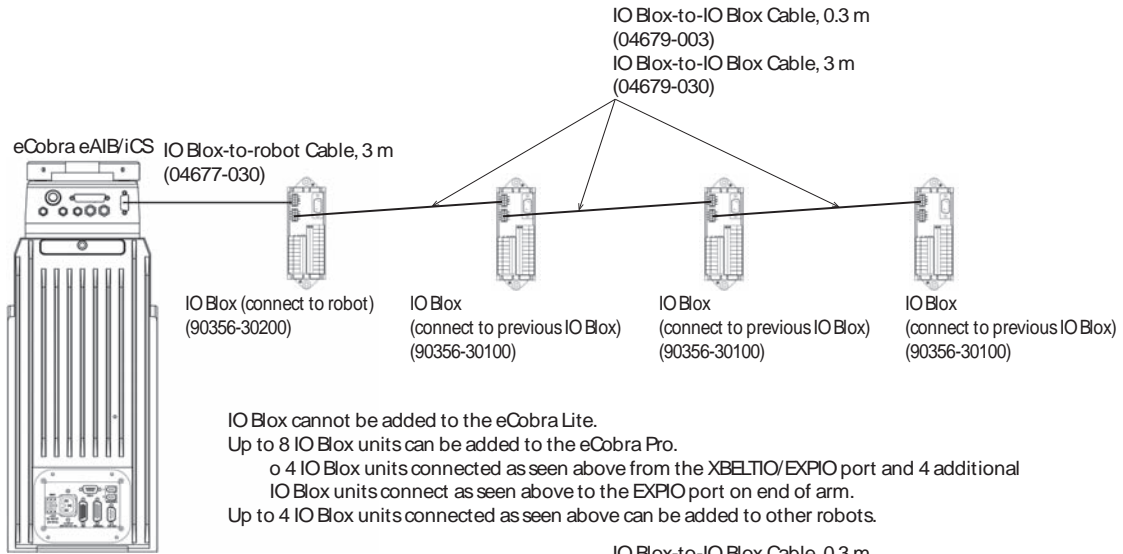

## Connecting XIO (12 inputs, 8 outputs) to increase I/O ports

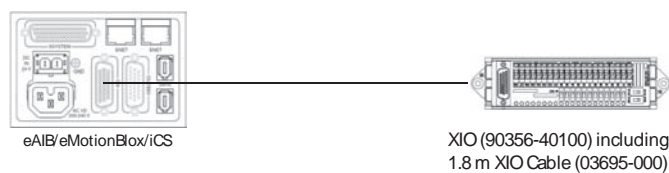

# Ordering Information

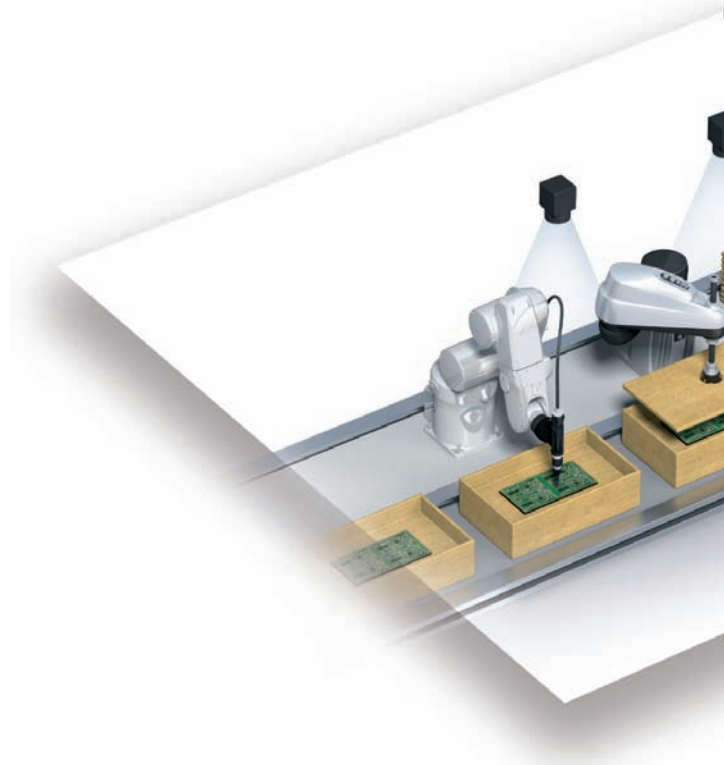

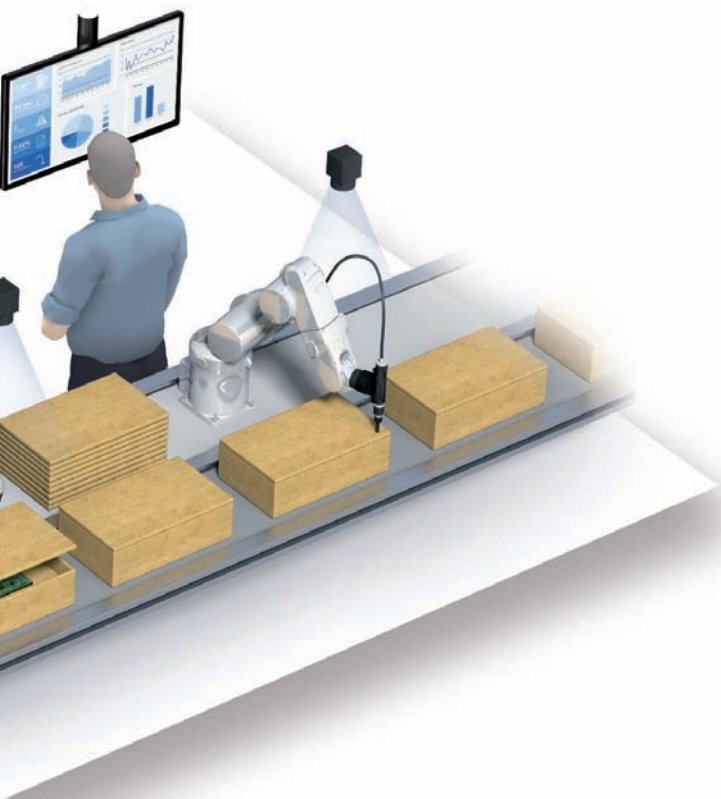

# Ordering Information

## Parallel Robots

### Part Number Structure

#### iX3 Robots with EtherCAT

**R X3-2 0 6 5 6 0 0**

(1) (2) (3) (4) (5) (6) (7) (8)

No.	Item	Symbol	Specifications
(1)	Industrial Robots		
(2)	Family	X3	iX3
(3)	Performance	2	Default
(4)	Version	0	
(5)	Configuration	6	with iCS-ECAT
(6)	Size	56	565 mm
(7)	Type	0	Standard
		1	IP65
(8)	Options	0	3-Axis
		4	4-Axis

#### Part Number List

Type	Part Number
iX3-565, 3 Axis, iCS-ECAT	RX3-2065600
iX3-565, 4 Axis, iCS-ECAT	RX3-2065604
iX3-565, 3 Axis, IP65, iCS-ECAT	RX3-2065610
iX3-565, 4 Axis, IP65, iCS-ECAT	RX3-2065614

#### iX4 Robots with EtherCAT

**R X4-2 1 6 6 0 0 0**

(1) (2) (3) (4) (5) (6) (7) (8)

No.	Item	Symbol	Specifications
(1)	Industrial Robots		
(2)	Family	X4	iX4
(3)	Performance	2	Default
(4)	Version	1	
(5)	Configuration	2	with iCS-ECAT
(6)	Size	60	650 mm
		63	800 mm
(7)	Type	0	Standard (H)
		1	HS
		2	IP65
(8)	Platform Options	0	P30
		1	P31
		2	P32
		4	P34

#### Part Number List

Type	Part Number
iX4-650H, P30, iCS-ECAT	RX4-2166000
iX4-650H, P31, iCS-ECAT	RX4-2166001
iX4-650H, P32, iCS-ECAT	RX4-2166002
iX4-650H, P34, iCS-ECAT	RX4-2166004
iX4-650HS, USDA, P30, iCS-ECAT	RX4-2166010
iX4-650HS, USDA, P31, iCS-ECAT	RX4-2166011
iX4-650HS, USDA, P32, iCS-ECAT	RX4-2166012
iX4-650HS, USDA, P34, iCS-ECAT	RX4-2166014
iX4-650H, IP65, P30, iCS-ECAT	RX4-2166020
iX4-650H, IP65, P31, iCS-ECAT	RX4-2166021
iX4-650H, IP65, P32, iCS-ECAT	RX4-2166022
iX4-650H, IP65, P34, iCS-ECAT	RX4-2166024
iX4-800H, P30, iCS-ECAT	RX4-2166300
iX4-800H, P31, iCS-ECAT	RX4-2166301
iX4-800H, P32, iCS-ECAT	RX4-2166302
iX4-800H, P34, iCS-ECAT	RX4-2166304
iX4-800HS, USDA, P30, iCS-ECAT	RX4-2166310
iX4-800HS, USDA, P31, iCS-ECAT	RX4-2166311
iX4-800HS, USDA, P32, iCS-ECAT	RX4-2166312
iX4-800HS, USDA, P34, iCS-ECAT	RX4-2166314
iX4-800H, IP65, P30, iCS-ECAT	RX4-2166320
iX4-800H, IP65, P31, iCS-ECAT	RX4-2166321
iX4-800H, IP65, P32, iCS-ECAT	RX4-2166322
iX4-800H, IP65, P34, iCS-ECAT	RX4-2166324

**Note:** The purpose of this part number structure is to provide understanding of the meaning of specifications from the part number.  
Part numbers are not available for all combinations of code numbers.

## Parallel Robots

### Part Number Structure

#### Hornet

**17 2 0 1 - 4 56 0 0**

(1) (2) (3) (4) (5) (6) (7) (8)

No.	Item	Symbol	Specifications
(1)	Industrial Robots		
(2)	Performance level	2	Pro
(3)	Version	0	
(4)	Configuration	1	Standard
		3	Add-On
(5)	Robot type	4	Hornet
(6)	Size	56	565 mm
		0	Standard
(7)	Cleanroom/IP rating	1	IP65/67
		0	3
(8)	Options	4	4

#### Part Number List

Type	Part Number
Hornet 565 4Axis	17201-45604
Hornet 565 3Axis	17201-45600
Hornet 565 4Axis IP65/67	17201-45614
Hornet 565 3Axis IP65/67	17201-45610
Hornet 565 4Axis Add-On	17203-45604
Hornet 565 3Axis Add-On	17203-45600
Hornet 565 4Axis IP65/67 Add-On	17203-45614
Hornet 565 3Axis IP65/67 Add-On	17203-45610
Quattro 650H P30	17214-26000
Quattro 650H P31	17214-26001
Quattro 650H P32	17214-26002
Quattro 650H P34	17214-26004
Quattro 650H P30 IP65/67	17214-26020
Quattro 650H P31 IP65/67	17214-26021
Quattro 650H P32 IP65/67	17214-26022
Quattro 650H P34 IP65/67	17214-26024
Quattro 650HS P30	17214-26010
Quattro 650HS P31	17214-26011
Quattro 650HS P32	17214-26012
Quattro 650HS P34	17214-26014
Quattro 800H P30	17214-26300
Quattro 800H P31	17214-26301
Quattro 800H P32	17214-26302
Quattro 800H P34	17214-26304
Quattro 800HS P30	17214-26310
Quattro 800HS P31	17214-26311
Quattro 800HS P32	17214-26312
Quattro 800HS P34	17214-26314

#### Quattro

**17 2 1 4 - 2 60 0 0**

(1) (2) (3) (4) (5) (6) (7) (8)

No.	Item	Symbol	Specifications
(1)	Industrial Robots		
(2)	Performance level	2	Pro
(3)	Version	1	
(4)	Configuration	3	Add-On
		4	with EX Controller
(5)	Robot type	2	Quattro
(6)	Size	60	650 mm
		63	800 mm
(7)	Cleanroom/IP rating /HS	0	Standard
		1	HS
		2	IP65/67
(8)	Options	0	P30
		1	P31
		2	P32
		4	P34

#### Part Number List

Type	Part Number
Quattro 800H P30 IP65/67	17214-26320
Quattro 800H P31 IP65/67	17214-26321
Quattro 800H P32 IP65/67	17214-26322
Quattro 800H P34 IP65/67	17214-26324
Quattro 650H P30 Add-On	17213-26000
Quattro 650H P31 Add-On	17213-26001
Quattro 650H P32 Add-On	17213-26002
Quattro 650H P34 Add-On	17213-26004
Quattro 650HS P30 Add-On	17213-26010
Quattro 650HS P31 Add-On	17213-26011
Quattro 650HS P32 Add-On	17213-26012
Quattro 650HS P34 Add-On	17213-26014
Quattro 650H P30 IP65/67 Add-On	17213-26020
Quattro 650H P31 IP65/67 Add-On	17213-26021
Quattro 650H P32 IP65/67 Add-On	17213-26022
Quattro 650H P34 IP65/67 Add-On	17213-26024
Quattro 800H P30 Add-On	17213-26300
Quattro 800H P31 Add-On	17213-26301
Quattro 800H P32 Add-On	17213-26302
Quattro 800H P34 Add-On	17213-26304
Quattro 800HS P30 Add-On	17213-26310
Quattro 800HS P31 Add-On	17213-26311
Quattro 800HS P32 Add-On	17213-26312
Quattro 800HS P34 Add-On	17213-26314
Quattro 800H P30 IP65/67 Add-On	17213-26320
Quattro 800H P31 IP65/67 Add-On	17213-26321
Quattro 800H P32 IP65/67 Add-On	17213-26322
Quattro 800H P34 IP65/67 Add-On	17213-26324

## SCARA Robots

### Part Number Structure

#### i4H Robot with EtherCAT

**R S4 - 2 0 6 6 5 0 2**

(1) (2) (3) (4) (5) (6) (7) (8) (9)

No.	Item	Symbol	Specifications
(1)	Industrial Robots		
(2)	Family	S4	i4
(3)	Performance Level	2	Default
(4)	Version	0	
(5)	Configuration	6	with iCS-ECAT
(6)	Size	6	650 mm
		7	750 mm
		8	850 mm
(7)	Type	5	Standard
		7	Inverted
(9)	Quill Length	2	210 mm
		4	410 mm

#### Part Number List

Type	Part Number
i4-650H Standard with iCS-ECAT	RS4-2066502
i4-650H Standard, Long Quill (410 mm) with iCS-ECAT	RS4-2066504
i4-650H Inverted with iCS-ECAT	RS4-2066702
i4-650H Inverted, Long Quill (410 mm) with iCS-ECAT	RS4-2066704
i4-750H Standard with iCS-ECAT	RS4-2067502
i4-750H Standard, Long Quill (410 mm) with iCS-ECAT	RS4-2067504
i4-750H Inverted with iCS-ECAT	RS4-2067702
i4-750H Inverted, Long Quill (410 mm) with iCS-ECAT	RS4-2067704
i4-850H Standard with iCS-ECAT	RS4-2068502
i4-850H Standard, Long Quill (410 mm) with iCS-ECAT	RS4-2068504
i4-850H Inverted with iCS-ECAT	RS4-2068702
i4-850H Inverted, Long Quill (410 mm) with iCS-ECAT	RS4-2068704

#### eCobra 600/800 Robot with EtherCAT

**R L4 - 1 1 6 6 0 0 0**

(1) (2) (3) (4) (5) (6) (7) (8)

No.	Item	Symbol	Specifications
(1)	Industrial Robots		
(2)	Family	L4	eCobra
(3)	Performance Level	1	Standard
		2	Pro
(4)	Version	1	
(5)	Configuration	6	with iCS-ECAT
(6)	Size	60	600 mm
		80	800 mm
		0	Standard
(7)	Cleanroom/IP rating	1	Class 10
		3	IP65 (not available for 600)
		0	None
(8)	Options	0	None

#### Part Number List

Type	Part Number
eCobra 600 Standard with iCS-ECAT	RL4-1166000
eCobra 600 Standard Cleanroom with iCS-ECAT	RL4-1166010
eCobra 600 Pro with iCS-ECAT	RL4-2166000
eCobra 600 Pro Cleanroom with iCS-ECAT	RL4-2166010
eCobra 800 Standard Cleanroom with iCS-ECAT	RL4-1168000
eCobra 800 Standard IP65 with iCS-ECAT	RL4-1168010
eCobra 800 Pro with iCS-ECAT	RL4-1168030
eCobra 800 Pro Cleanroom with iCS-ECAT	RL4-2168000
eCobra 800 Pro IP65 with iCS-ECAT	RL4-2168010

**Note:** The purpose of this part number structure is to provide understanding of the meaning of specifications from the part number.  
Part numbers are not available for all combinations of code numbers.



## SCARA Robots

### Part Number Structure

#### Cobra 450/500/650

**17 2 0 1 - 1 45 0 0**

(1) (2) (3) (4) (5) (6) (7) (8)

No.	Item	Symbol	Specifications
(1)	Industrial Robots		
(2)	Performance level	2	Pro
(3)	Version	0	
(4)	Configuration	1	Standard
		3	Add-On
(5)	Robot type	1	Cobra
(6)	Size	45	450 mm
		50	500 mm
		65	650 mm
(7)	Cleanroom/IP rating	0	Standard
(8)	Options	0	None

#### Part Number List

Type	Part Number
Cobra 450	17201-14500
Cobra 500	17201-15000
Cobra 650	17201-16500
eCobra 600 Lite	17010-16000
eCobra 600 Standard	17111-16000
eCobra 600 Pro	17211-16000
eCobra 600 Lite Cleanroom	17010-16010
eCobra 600 Standard Cleanroom	17111-16010
eCobra 600 Pro Cleanroom	17211-16010
eCobra 800 Lite	17010-18000
eCobra 800 Standard	17111-18000
eCobra 800 Pro	17211-18000
eCobra 800 Lite Cleanroom	17010-18010
eCobra 800 Standard Cleanroom	17111-18010
eCobra 800 Pro Cleanroom	17211-18010
eCobra 800 Lite IP65	17010-18030
eCobra 800 Standard IP65	17111-18030
eCobra 800 Pro IP65	17211-18030
eCobra 800 Inverted Lite	17010-18400
eCobra 800 Inverted Standard	17111-18400
eCobra 800 Inverted Pro	17211-18400
eCobra 800 Inverted Lite Cleanroom	17010-18410
eCobra 800 Inverted Standard Cleanroom	17111-18410
eCobra 800 Inverted Pro Cleanroom	17211-18410
eCobra 800 Inverted Lite IP65	17010-18430
eCobra 800 Inverted Standard IP65	17111-18430
eCobra 800 Inverted Pro IP65	17211-18430

#### eCobra 600/800/800Inverted

**17 0 1 0 - 1 60 0 0**

(1) (2) (3) (4) (5) (6) (7) (8)

No.	Item	Symbol	Specifications
(1)	Industrial Robots		
(2)	Performance level	0	Lite
		1	Standard
		2	Pro
(3)	Version	1	
(4)	Configuration	0	ePLC not supported
		1	Standard
		3	Add-On
(5)	Robot type	1	eCobra
(6)	Size	60	600 mm
		80	800 mm
		84	800 mm Inverted
(7)	Cleanroom/IP rating	0	Standard
		1	Class 10
		3	IP65 (not available for 600 mm)
(8)	Options	0	None

#### Part Number List

Type	Part Number
Cobra 450 Add-On	17203-14500
Cobra 500 Add-On	17203-15000
Cobra 650 Add-On	17203-16500
eCobra 600 Standard Add-On	17113-16000
eCobra 600 Pro Add-On	17213-16000
eCobra 600 Standard Cleanroom Add-On	17113-16010
eCobra 600 Pro Cleanroom Add-On	17213-16010
eCobra 800 Standard Add-On	17113-18000
eCobra 800 Pro Add-On	17213-18000
eCobra 800 Standard Cleanroom Add-On	17113-18010
eCobra 800 Pro Cleanroom Add-On	17213-18010
eCobra 800 Standard IP65 Add-On	17113-18030
eCobra 800 Pro IP65 Add-On	17213-18030
eCobra 800 Inverted Standard Add-On	17113-18400
eCobra 800 Inverted Pro Add-On	17213-18400
eCobra 800 Inverted Standard Cleanroom Add-On	17113-18410
eCobra 800 Inverted Pro Cleanroom Add-On	17213-18410
eCobra 800 Inverted Standard IP65 Add-On	17113-18430
eCobra 800 Inverted Pro IP65 Add-On	17213-18430

**Note:** The purpose of this part number structure is to provide understanding of the meaning of specifications from the part number.  
Part numbers are not available for all combinations of code numbers.

## SCARA Robots

### Part Number Structure

i4L Robot with ENET

**RS4 - 2053002**

(1) (2) (3) (4) (5) (6) (7) (8) (9)

No.	Item	Symbol	Specifications
(1)	Industrial Robots		
(2)	Family	S4	i4
(3)	Performance Level	2	Default
(4)	Version	0	
(5)	Configuration	5	with iCS-ENET
(6)	Size	3	350 mm
		4	450 mm
		5	550 mm
(7)	Interface Panel Orientation	0	Rear
		1	Bottom
(9)	Quill Length	2	180 mm
		4	350 mm

### Part Number List

Type	Part Number
i4-350L Rear Panel with iCS ENET	RS4-2053002
i4-450L Rear Panel with iCS ENET	RS4-2054002
i4-550L Rear Panel with iCS ENET	RS4-2055002
i4-550L 350 mm-Z Rear Panel with iCS ENET	RS4-2055004
i4-350L Bottom Panel with iCS ENET	RS4-2053102
i4-450L Bottom Panel with iCS ENET	RS4-2054102
i4-550L Bottom Panel with iCS ENET	RS4-2055102
i4-550L 350 mm-Z Bottom Panel with iCS ENET	RS4-2055104

**Note:** The purpose of this part number structure is to provide understanding of the meaning of specifications from the part number.  
Part numbers are not available for all combinations of code numbers.

## Articulated Robots

### Part Number Structure

Viper 650/850 Robot with EtherCAT

**R L6 - 2 0 6 60 0 0**

(1) (2) (3) (4) (5) (6) (7) (8)

No.	Item	Symbol	Specifications
(1)	Industrial Robots		
(2)	Family	L6	Viper
(3)	Performance Level	2	Performance (Default 2 for Viper Robots)
(4)	Version	0	
(5)	Configuration	6	with eCS-ECAT
(6)	Size	60	650 mm
		80	850 mm
(7)	Cleanroom/IP rating	0	Standard
		1	IP54/65
		2	Class10
(8)	Options	0	None

### Part Number List

Type	Part Number
Viper 650 with eCS-ECAT	RL6-2066000
Viper 650 IP54/65 with eCS-ECAT	RL6-2066010
Viper 650 Cleanroom with eCS-ECAT	RL4-2166000
Viper 850 with eCS-ECAT	RL6-2068000
Viper 850 IP54/65 with eCS-ECAT	RL62068010
Viper 850 Cleanroom with eCS-ECAT	RL4-1168010

Viper

**17 2 0 1 - 3 60 0 0**

(1) (2) (3) (4) (5) (6) (7) (8)

No.	Item	Symbol	Specifications
(1)	Industrial Robots		
(2)	Performance level	2	Pro
(3)	Version	2	Performance (Default 2 for Viper Robots)
(4)	Configuration	0	
		6	with eCS-ECAT
(5)	Robot type	3	Viper
(6)	Size	60	650 mm
		80	850 mm
		84	850 mm Inverted
(7)	Cleanroom/IP rating	0	Standard
		1	IP54/65
		2	Class 10
(8)	Options	0	None

### Part Number List

Type	Part Number
Viper 650	17201-36000
Viper 650 Cleanroom	17201-36020
Viper 650 IP54/65	17201-36010
Viper 850	17201-38000
Viper 850 Cleanroom	17201-38020
Viper 850 IP54/65	17201-38010
Viper 650 Add-On	17203-36000
Viper 650 Cleanroom Add-On	17203-36020
Viper 650 IP54/65 Add-On	17203-36010
Viper 850 Add-On	17203-38000
Viper 850 Cleanroom Add-On	17203-38020
Viper 850 IP54/65 Add-On	17203-38010

**Note:** The purpose of this part number structure is to provide understanding of the meaning of specifications from the part number.  
Part numbers are not available for all combinations of code numbers.

## Related Documentation

Cat. No.	Manual
I590	Robot Safety Guide
I593	eCobra 600, 800, and 800 Inverted Robots User's Guide
I594	eCobra 600, 800, and 800 Inverted Robots ePLC Quick Setup Guide
I595	Hornet 565 Robot Quick Setup Guide
I596	Hornet 565 Robot User's Guide
I597	Quattro 650H/650HS/800H/800HS User's Guide
I598	Quattro 650H/650HS/800H/800HS ePLC Quick Setup Guide
I599	Viper 650/850 Robot with eMB-60R User's Guide
I600	Viper 650/850 ePLC Quick Setup Guide
I601	T20 Pendant User's Guide
I602	SmartController EX user's guide
I603	ACE User's Guide
I604	eV+ Language User's Guide
I605	eV+ Language Reference Guide
I606	eV+ Operating System User's Guide
I607	eV+ Operating System Reference Guide
I608	SmartVision MX User's Guide
I609	ACE Sight Reference Guide
I632	IPC Application Controller User's Manual
I633	Automation Control Environment(ACE) Version4 User's Manual
I651	eV+3 User's Manual
I652	eV+3 Keyword Reference Manual
I653	eCobra 600 and 800 with iCS-ECAT User's Manual
I654	Viper 650 and 850 with eCS-eCS-ECAT User's Manual
I658	i4L Robot User's Manual
I661	i4H Robot with EtherCAT User's Manual
I655	iX3 565 Robot with EtherCAT User's Manual
I656	iX4 650 H/HS and 800 H/HS Robot with EtherCAT User's Manual
I832	Cobra 450, 500, and 650 Robot User's Guide
O037	NJ-series Robot Integrated CPU Unit User's Manual
O049	NJ-series Robot Integrated System Startup Guide
W595	Sysmac Studio Integrated Robot System Control Function Operation Manual

# Terms and Conditions Agreement

## **Read and understand this catalog.**

Please read and understand this catalog before purchasing the products. Please consult your OMRON representative if you have any questions or comments.

## **Warranties.**

- (a) Exclusive Warranty. Omron's exclusive warranty is that the Products will be free from defects in materials and workmanship for a period of twelve months from the date of sale by Omron (or such other period expressed in writing by Omron). Omron disclaims all other warranties, express or implied.
- (b) Limitations. OMRON MAKES NO WARRANTY OR REPRESENTATION, EXPRESS OR IMPLIED, ABOUT NON-INFRINGEMENT, MERCHANTABILITY OR FITNESS FOR A PARTICULAR PURPOSE OF THE PRODUCTS. BUYER ACKNOWLEDGES THAT IT ALONE HAS DETERMINED THAT THE PRODUCTS WILL SUITABLY MEET THE REQUIREMENTS OF THEIR INTENDED USE.

Omron further disclaims all warranties and responsibility of any type for claims or expenses based on infringement by the Products or otherwise of any intellectual property right. (c) Buyer Remedy. Omron's sole obligation hereunder shall be, at Omron's election, to (i) replace (in the form originally shipped with Buyer responsible for labor charges for removal or replacement thereof) the non-complying Product, (ii) repair the non-complying Product, or (iii) repay or credit Buyer an amount equal to the purchase price of the non-complying Product; provided that in no event shall Omron be responsible for warranty, repair, indemnity or any other claims or expenses regarding the Products unless Omron's analysis confirms that the Products were properly handled, stored, installed and maintained and not subject to contamination, abuse, misuse or inappropriate modification. Return of any Products by Buyer must be approved in writing by Omron before shipment. Omron Companies shall not be liable for the suitability or unsuitability or the results from the use of Products in combination with any electrical or electronic components, circuits, system assemblies or any other materials or substances or environments. Any advice, recommendations or information given orally or in writing, are not to be construed as an amendment or addition to the above warranty.

See <http://www.omron.com/global/> or contact your Omron representative for published information.

## **Limitation on Liability; Etc.**

OMRON COMPANIES SHALL NOT BE LIABLE FOR SPECIAL, INDIRECT, INCIDENTAL, OR CONSEQUENTIAL DAMAGES, LOSS OF PROFITS OR PRODUCTION OR COMMERCIAL LOSS IN ANY WAY CONNECTED WITH THE PRODUCTS, WHETHER SUCH CLAIM IS BASED IN CONTRACT, WARRANTY, NEGLIGENCE OR STRICT LIABILITY.

Further, in no event shall liability of Omron Companies exceed the individual price of the Product on which liability is asserted.

## **Suitability of Use.**

Omron Companies shall not be responsible for conformity with any standards, codes or regulations which apply to the combination of the Product in the Buyer's application or use of the Product. At Buyer's request, Omron will provide applicable third party certification documents identifying ratings and limitations of use which apply to the Product. This information by itself is not sufficient for a complete determination of the suitability of the Product in combination with the end product, machine, system, or other application or use. Buyer shall be solely responsible for determining appropriateness of the particular Product with respect to Buyer's application, product or system. Buyer shall take application responsibility in all cases.

NEVER USE THE PRODUCT FOR AN APPLICATION INVOLVING SERIOUS RISK TO LIFE OR PROPERTY OR IN LARGE QUANTITIES WITHOUT ENSURING THAT THE SYSTEM AS A WHOLE HAS BEEN DESIGNED TO ADDRESS THE RISKS, AND THAT THE OMRON PRODUCT(S) IS PROPERLY RATED AND INSTALLED FOR THE INTENDED USE WITHIN THE OVERALL EQUIPMENT OR SYSTEM.

## **Programmable Products.**

Omron Companies shall not be responsible for the user's programming of a programmable Product, or any consequence thereof.

## **Performance Data.**

Data presented in Omron Company websites, catalogs and other materials is provided as a guide for the user in determining suitability and does not constitute a warranty. It may represent the result of Omron's test conditions, and the user must correlate it to actual application requirements. Actual performance is subject to the Omron's Warranty and Limitations of Liability.

## **Change in Specifications.**

Product specifications and accessories may be changed at any time based on improvements and other reasons. It is our practice to change part numbers when published ratings or features are changed, or when significant construction changes are made. However, some specifications of the Product may be changed without any notice. When in doubt, special part numbers may be assigned to fix or establish key specifications for your application. Please consult with your Omron's representative at any time to confirm actual specifications of purchased Product.

## **Errors and Omissions.**

Information presented by Omron Companies has been checked and is believed to be accurate; however, no responsibility is assumed for clerical, typographical or proofreading errors or omissions.

**Note: Do not use this document to operate the Unit.**

**OMRON Corporation Industrial Automation Company**

**Kyoto, JAPAN**

**Contact : [www.ia.omron.com](http://www.ia.omron.com)**

**Regional Headquarters**

**OMRON EUROPE B.V.**

Wegalaan 67-69, 2132 JD Hoofddorp  
The Netherlands  
Tel: (31) 2356-81-300 Fax: (31) 2356-81-388

**OMRON ASIA PACIFIC PTE. LTD.**

438B Alexandra Road, #08-01/02 Alexandra  
Technopark, Singapore 119968  
Tel: (65) 6835-3011 Fax: (65) 6835-3011

**OMRON ELECTRONICS LLC**

2895 Greenspoint Parkway, Suite 200  
Hoffman Estates, IL 60169 U.S.A.  
Tel: (1) 847-843-7900 Fax: (1) 847-843-7787

**OMRON ROBOTICS AND SAFETY TECHNOLOGIES, INC.**

4225 Hacienda Drive, Pleasanton, CA 94588 U.S.A.  
Tel: (1) 925-245-3400 Fax: (1) 925-960-0590

**OMRON (CHINA) CO., LTD.**

Room 2211, Bank of China Tower, 200 Yin Cheng Zhong Road,  
PuDong New Area, Shanghai, 200120, China  
Tel: (86) 21-6023-0333 Fax: (86) 21-5037-2388

**Authorized Distributor:**

©OMRON Corporation 2016-2024 All Rights Reserved.  
In the interest of product improvement,  
specifications are subject to change without notice.

**CSM\_14\_1**

**Cat. No. I822-E1-22 1024 (0316)**