

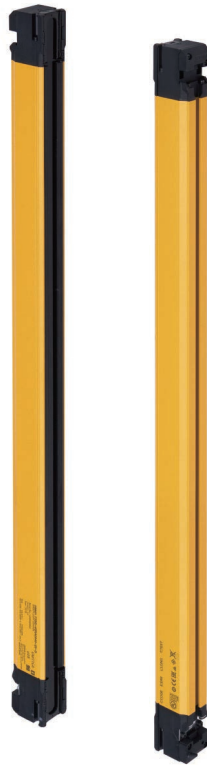

Safety Light Curtain F3SG-□SR□ Series
Safety Multi-Light Beam F3SG-□PG□ Series

User's Manual



Original instructions

Introduction

Thank you for purchasing the F3SG-SR Series Safety Light Curtain (hereafter called the "F3SG-SR", "F3SG-SRA", "F3SG-SRB", or "sensor")/F3SG-PG Series Safety Multi-Light Beam (hereafter called the "F3SG-PGA-A", "F3SG-PGA-L", "F3SG-PGA-C", or "sensor").

This is the instruction Manual describing the use of F3SG-SR/PG.

Always heed the following points when using the product:

- Be sure to have F3SG-SR/PG be handled by a "Responsible Person" who is well aware of and familiar with the machine to be installed.
- The term "Responsible Person" used in this document means the person qualified, authorized and responsible to secure "safety" in each process of the design, installation, operation, maintenance services and disposition of the machine.
- It is assumed that the F3SG-SR/PG will be used properly according to the installation environment, performance and function of the machine. Responsible Person should conduct risk assessment on the machine and determine the suitability of this product before installation.
- Read this document thoroughly to understand and make good use of the descriptions before installing and operating the product.
- Keep this document at the place where the operator can refer to whenever necessary.

Trademarks

- Microsoft product screen shot(s) reprinted with permission from Microsoft Corporation.
- Windows, Windows 7, Windows 8, Windows 10, Windows11, Microsoft .NET Framework, and Surface are either registered trademarks or trademarks of Microsoft Corporation in the USA and other countries.
- Official name of Windows 7 is Microsoft Windows 7 Operating System.
- Official name of Windows 8 is Microsoft Windows 8 Operating System.
- Official name of Windows 10 is Microsoft Windows 10 Operating System.
- Official name of Windows 11 is Microsoft Windows 11 Operating System.
- USB Type-C™ is a trademark of USB Implementers Forum.
- The Bluetooth® word mark and logos are registered trademarks owned by Bluetooth SIG, Inc.
- Google and Android are trademarks of Google LLC.
- Xperia is either a registered trademark or a trademark of Sony Mobile Communications Inc.
- SHARP and AQUOS are registered trademarks of Sharp Corporation.
- ASUS is a trademark of ASUSTeK Computer Inc.
- GALAXY S is a registered trademark of Samsung Electronics Co., Ltd.
- HUAWEI is either a registered trademark or a trademark of HUAWEI TECHNOLOGIES Co., Ltd.
- Mi and XIAOMI are either registered trademarks or trademarks of BEIJING XIAOMI TECHNOLOGY CO., LTD.
- Other company names and product names in this document are the trademarks or registered trademarks of their respective companies.

Legislation and Standards

1. The F3SG-SR/PG does not receive type approval provided by Article 44-2 of the Industrial Safety and Health Act of Japan. When using the F3SG-SR/PG in Japan as a "safety system for pressing or shearing machines" prescribed in Article 42 of that law, the machine control system must receive type approval.
2. The F3SG-SR/PG is electro-sensitive protective equipment (ESPE) in accordance with European Union (EU) Machinery Directive Index Annex V, Item 2.
3. EU Declaration of Conformity
OMRON declares that the F3SG-SR/PG is in conformity with the requirements of the following EU Directives:
Machinery Directive 2006/42/EC
EMC Directive 2014/30/EU
4. Conforming Standards
 - (1) European standards
EN61496-1 (Type 4 and Type 2 ESPE), EN 61496-2 (Type 4 and Type 2 AOPD), EN61508-1 through -4 (SIL 3 for Type 4 and SIL 1 for Type 2),
EN ISO 13849-1:2015 (PL e, Category 4 for Type 4 and PL c, Category 2 for Type 2)
 - (2) International standards
IEC61496-1 (Type 4 and Type 2 ESPE), IEC61496-2 (Type 4 and Type 2 AOPD), IEC61508-1 through -4 (SIL 3 for Type 4 and SIL 1 for Type 2),
ISO 13849-1:2015 (PL e, Category 4 for Type 4 and PL c, Category 2 for Type 2)
 - (3) JIS standards
JIS B 9704-1 (Type 4 and Type 2 ESPE), JIS B 9704-2 (Type 4 and Type 2 AOPD)
 - (4) North American standards
UL61496-1 (Type 4 and Type 2 ESPE), UL61496-2 (Type 4 and Type 2 AOPD), UL508, UL1998,
CAN/CSA C22.2 No.14, CAN/CSA C22.2 No.0.8
 - (5) Chinese standards
GB/T 4584 (Specification of active opto-electronic protective devices for presses)
(Models: F3SG-4SR□□□□□-14/-25)

 The F3SG-SR's with detection capability of 45-mm and 85-mm dia. are not compliant with GB/T 4584.

CHECK!

 Refer to 1-5. *Ratings and Specifications* for more information on the ratings and specifications by model.
5. Third-Party Certifications
 - (1) TÜV SÜD
 - EC Type-Examination certificate:
EU Machinery Directive, Type 4 and Type 2 ESPE (EN61496-1), Type 4 and Type 2 AOPD (EN 61496-2)
 - Certificate:
Type 4 and Type 2 ESPE (EN61496-1), Type 4 and Type 2 AOPD (EN61496-2), EN 61508-1 through -4 (SIL 3 for Type 4 and SIL 1 for Type 2), EN ISO 13849-1:2015 (PL e, Category 4 for Type 4, and PL c, Category 2 for Type 2)
 - (2) UL
 - UL Listing:
Type 4 and Type 2 ESPE (UL61496-1), Type 4 and Type 2 AOPD (UL61496-2), UL508, UL1998, CAN/CSA C22.2 No.14, CAN/CSA C22.2 No.0.8

(3) China National Casting and Forging Machines Quality Supervision and Inspection Center

- Certificate:
GB/T 4584 (Specification of active opto-electronic protective devices for presses)
(Models: F3SG-4SR□□□□□-14/-25)

6. Other Standards

The F3SG-SR/PG is designed according to the standards listed below. To make sure that the final system complies with the following standards and regulations, you are asked to design and use it in accordance with all other related standards, laws, and regulations. If you have any questions, consult with specialized organizations such as the body responsible for prescribing and/or enforcing machinery safety regulations in the location where the equipment is to be used.

- European Standards: EN415-4, EN691-1, EN692, EN693, IEC 62046
- U.S. Occupational Safety and Health Standards: OSHA 29 CFR 1910.212
- U.S. Occupational Safety and Health Standards: OSHA 29 CFR 1910.217
- American National Standards: ANSI B11.1 to B11.19
- American National Standards: ANSI/RIA R15.06
- Canadian Standards Association CSA Z142, Z432, Z434
- SEMI Standards SEMI S2
- Japan Ministry of Health, Labour and Welfare "Guidelines for Comprehensive Safety Standards of Machinery", Standard Bureau's Notification No. 0731001 dated July 31, 2007.rms and Conditions Agreement
- Chinese National Standards: GB17120, GB27607

7. Meaning of mark according to EU WEEE Directive



Dispose in accordance with applicable regulations.

8. Regions where F39-SGBT can be used

For the regions where the F39-SGBT can be used, refer to the following instruction manuals of the F39-SGBT.

Document Title	No.
F39-SGBT Instruction Sheet	4615743-0
F39-SGBT Regulations and Standards	4615744-8

Terms and Conditions Agreement

Warranties.

- (a) Exclusive Warranty. Omron's exclusive warranty is that the Products will be free from defects in materials and workmanship for a period of twelve months from the date of sale by Omron (or such other period expressed in writing by Omron). Omron disclaims all other warranties, express or implied.
- (b) Limitations. OMRON MAKES NO WARRANTY OR REPRESENTATION, EXPRESS OR IMPLIED, ABOUT NON-INFRINGEMENT, MERCHANTABILITY OR FITNESS FOR A PARTICULAR PURPOSE OF THE PRODUCTS. BUYER ACKNOWLEDGES THAT IT ALONE HAS DETERMINED THAT THE PRODUCTS WILL SUITABLY MEET THE REQUIREMENTS OF THEIR INTENDED USE.

Omron further disclaims all warranties and responsibility of any type for claims or expenses based on infringement by the Products or otherwise of any intellectual property right. (c) Buyer Remedy. Omron's sole obligation hereunder shall be, at Omron's election, to (i) replace (in the form originally shipped with Buyer responsible for labor charges for removal or replacement thereof) the non-complying Product, (ii) repair the non-complying Product, or (iii) repay or credit Buyer an amount equal to the purchase price of the non-complying Product; provided that in no event shall Omron be responsible for warranty, repair, indemnity or any other claims or expenses regarding the Products unless Omron's analysis confirms that the Products were properly handled, stored, installed and maintained and not subject to contamination, abuse, misuse or inappropriate modification. Return of any Products by Buyer must be approved in writing by Omron before shipment. Omron Companies shall not be liable for the suitability or unsuitability or the results from the use of Products in combination with any electrical or electronic components, circuits, system assemblies or any other materials or substances or environments. Any advice, recommendations or information given orally or in writing, are not to be construed as an amendment or addition to the above warranty.

See <http://www.omron.com/global/> or contact your Omron representative for published information.

Limitation on Liability; Etc.

OMRON COMPANIES SHALL NOT BE LIABLE FOR SPECIAL, INDIRECT, INCIDENTAL, OR CONSEQUENTIAL DAMAGES, LOSS OF PROFITS OR PRODUCTION OR COMMERCIAL LOSS IN ANY WAY CONNECTED WITH THE PRODUCTS, WHETHER SUCH CLAIM IS BASED IN CONTRACT, WARRANTY, NEGLIGENCE OR STRICT LIABILITY.

Further, in no event shall liability of Omron Companies exceed the individual price of the Product on which liability is asserted.

Suitability of Use.

Omron Companies shall not be responsible for conformity with any standards, codes or regulations which apply to the combination of the Product in the Buyer's application or use of the Product. At Buyer's request, Omron will provide applicable third party certification documents identifying ratings and limitations of use which apply to the Product. This information by itself is not sufficient for a complete determination of the suitability of the Product in combination with the end product, machine, system, or other application or use. Buyer shall be solely responsible for determining appropriateness of the particular Product with respect to Buyer's application, product or system. Buyer shall take application responsibility in all cases.

NEVER USE THE PRODUCT FOR AN APPLICATION INVOLVING SERIOUS RISK TO LIFE OR PROPERTY OR IN LARGE QUANTITIES WITHOUT ENSURING THAT THE SYSTEM AS A WHOLE HAS BEEN DESIGNED TO ADDRESS THE RISKS, AND THAT THE OMRON PRODUCT(S) IS PROPERLY RATED AND INSTALLED FOR THE INTENDED USE WITHIN THE OVERALL EQUIPMENT OR SYSTEM.

Programmable Products.

Omron Companies shall not be responsible for the user's programming of a programmable Product, or any consequence thereof.

Performance Data.

Data presented in Omron Company websites, catalogs and other materials is provided as a guide for the user in determining suitability and does not constitute a warranty. It may represent the result of Omron's test conditions, and the user must correlate it to actual application requirements. Actual performance is subject to the Omron's Warranty and Limitations of Liability.

Change in Specifications.

Product specifications and accessories may be changed at any time based on improvements and other reasons. It is our practice to change part numbers when published ratings or features are changed, or when significant construction changes are made. However, some specifications of the Product may be changed without any notice. When in doubt, special part numbers may be assigned to fix or establish key specifications for your application. Please consult with your Omron's representative at any time to confirm actual specifications of purchased Product.

Errors and Omissions.

Information presented by Omron Companies has been checked and is believed to be accurate; however, no responsibility is assumed for clerical, typographical or proofreading errors or omissions.

Terms and Conditions Agreement (Software)

1. WARRANTY

- (1) The warranty period for the Software is one year from the date of purchase, unless otherwise specifically agreed.
- (2) If the User discovers defect of the Software (substantial non-conformity with the manual), and return it to OMRON within the above warranty period, OMRON will replace the Software without charge by offering media or download from OMRON's website. And if the User discovers defect of media which is attributable to OMRON and return it to OMRON within the above warranty period, OMRON will replace defective media without charge. If OMRON is unable to replace defective media or correct the Software, the liability of OMRON and the User's remedy shall be limited to the refund of the license fee paid to OMRON for the Software.

2. LIMITATION OF LIABILITY

- (1) THE ABOVE WARRANTY SHALL CONSTITUTE THE USER'S SOLE AND EXCLUSIVE REMEDIES AGAINST OMRON AND THERE ARE NO OTHER WARRANTIES, EXPRESSED OR IMPLIED, INCLUDING BUT NOT LIMITED TO, WARRANTY OF MERCHANTABILITY OR FITNESS FOR PARTICULAR PURPOSE. IN NO EVENT, OMRON WILL BE LIABLE FOR ANY LOST PROFITS OR OTHER INDIRECT, INCIDENTAL, SPECIAL OR CONSEQUENTIAL DAMAGES ARISING OUT OF USE OF THE SOFTWARE.
- (2) OMRON SHALL HAVE NO LIABILITY FOR DEFECT OF THE SOFTWARE BASED ON MODIFICATION OR ALTERNATION TO THE SOFTWARE BY THE USER OR ANY THIRD PARTY. OMRON SHALL NOT BE RESPONSIBLE AND/OR LIABLE FOR ANY LOSS, DAMAGE, OR EXPENSES DIRECTLY OR INDIRECTLY RESULTING FROM THE INFECTION OF OMRON PRODUCTS, ANY SOFTWARE INSTALLED THEREON OR ANY COMPUTER EQUIPMENT, COMPUTER PROGRAMS, NETWORKS, DATABASES OR OTHER PROPRIETARY MATERIAL CONNECTED THERETO BY DISTRIBUTED DENIAL OF SERVICE ATTACK, COMPUTER VIRUSES, OTHER TECHNOLOGICALLY HARMFUL MATERIAL AND/OR UNAUTHORIZED ACCESS.
- (3) OMRON SHALL HAVE NO LIABILITY FOR SOFTWARE DEVELOPED BY THE USER OR ANY THIRD PARTY BASED ON THE SOFTWARE OR ANY CONSEQUENCE THEREOF.

3. APPLICABLE CONDITIONS

USER SHALL NOT USE THE SOFTWARE FOR THE PURPOSE THAT IS NOT PROVIDED IN THE ATTACHED USER MANUAL.

4. CHANGE IN SPECIFICATION

The software specifications and accessories may be changed at any time based on improvements and other reasons.

5. ERRORS AND OMISSIONS



The information in this manual has been carefully checked and is believed to be accurate; however, no responsibility is assumed for clerical, typographical, or proofreading errors, or omissions.

Safety Precautions



■ Indications and meanings for safe use

The precautions listed in this document indicated by alert symbols and statements must be followed for the safe use of the F3SG-SR/PG. Failure to follow all precautions and alerts may result in an unsafe use or operation. The following word and symbols are used in this document.

<Meaning of signal words>

 DANGER	Indicates an imminently hazardous situation which, if not avoided, is likely to result in serious injury or may result in death. Additionally there may be severe property damage.
 WARNING	Indicates a potentially hazardous situation which, if not avoided, will result in minor or moderate injury, or may result in serious injury or death. Additionally there may be significant property damage.

<Meaning of alert symbols>

	Indicates prohibited actions.
	Indicates mandatory actions.
	Indicates the risk of electric shock.

■ Alert statements

DANGER

Make sure that the machine can be controlled correctly and as intended. Also make sure that the machine can be stopped immediately at any time of the operation cycle without danger to machine operators when the machine behavior does not meet safety-related requirements. Otherwise, continued use of the machine may result in serious injury or death.



Users

WARNING

The F3SG-SR/PG must be installed, configured, and incorporated into a machine control system by a sufficiently trained and qualified person. An unqualified person may not be able to perform these operations properly, which may cause a person to go undetected, resulting in serious injury.



Machines

WARNING

Do not use this sensor for machines that cannot be stopped quickly by electrical control. For example, do not use it for a pressing machine that uses full-rotation clutch. Otherwise, the machine may not stop before a person reaches the hazardous part, resulting in serious injury.



To use the F3SG-SR in PSDI mode (initiation of cyclic operation by a presence sensing device), you must configure an appropriate circuit between the F3SG-SR and the machine. For details about PSDI, refer to OSHA 1910.217, IEC 61496-1, and other relevant standards and regulations.



Installation

WARNING

Make sure Responsible Person tests the operation of the F3SG-SR/PG and F39-SGIT-IL3 after installation to verify that the F3SG-SR/PG and F39-SGIT-IL3 operate as intended. Make sure to stop the machine until the test is complete. Unintended installation, wiring or function settings may cause a person to go undetected, resulting in serious injury.



Make sure to install the F3SG-SR/PG at the safety distance from the hazardous part of the machine. Otherwise, the machine may not stop before a person reaches the hazardous part, resulting in serious injury.



Install a protective structure so that the hazardous part of a machine can only be reached by passing through the sensor's detection zone. If access to the hazardous part by reaching over the detection zone of a vertically mounted F3SG-SR/PG cannot be excluded, the height of the detection zone and the safety distance shall be determined in consideration of such a risk. Install the sensors so that part of the person is always present in the detection zone when working in a machine's hazardous zones. If a person is able to step into the hazardous zone of a machine and remain behind the F3SG-SR/PG's detection zone, configure the system with Restart Interlock function. Failure to do so may result in serious injury due to unexpected startup.



Install the reset switch in a location that provides a clear view of the entire hazardous zone and where it cannot be activated from within the hazardous zone.



Install the pre-reset switch always in the hazardous zone and where it cannot be activated from outside the hazardous zone.



The F3SG-SR/PG cannot protect a person from an object flying from the hazardous zone. Install protective cover(s) or fence(s).



Install a protective structure to cover the whole blanked zone in order to prevent personnel approach to hazardous part of the machine through the blanked zone.



Detection capability gets larger when Fixed Blanking, Floating Blanking or Reduced Resolution function is used. When these functions are used, the safety distance calculation must be based on the increased detection capability for these functions. Otherwise, the machine may not stop before a person reaches to the hazardous part, resulting in serious injury.



If detection capability may get larger and a human body may pass a detection zone to reach a hazardous source, additional safety protection equipment must be installed such as a safety fence.



A warning zone must not be used for safety applications. Always install your system so that a detection zone should be passed before reaching a hazardous part of the machine. If access to the hazardous part by reaching over the detection zone of a vertically mounted F3SG-SR cannot be excluded, the height of the detection zone and the safety distance shall be determined in consideration of such a risk.



When a warning zone is configured, you must attach labels that indicate a border between normal detection zone and warning zone. Otherwise, the machine may not stop before a person reaches to the hazardous part, resulting in serious injury.



A warning zone must be configured based on a safety distance.



The Muting and Override functions disable the safety functions of the device. Especially setting the Muting Time Limit parameter to infinite may cause the safety functions to be disabled for a long time. Install the F3SG-SR/PG, muting sensor and physical barrier and configure time settings for Muting and Override so that an operator should not enter hazardous zone when the Muting and Override are active.



Install muting sensors so that they can distinguish between the object that is being allowed to pass through the detection zone and a person. If the Muting function is activated by the detection of a person, the machine may not stop operating, resulting in serious injury.



Muting lamps that indicate the state of the Muting and Override functions must be installed where they are clearly visible to workers from all the operating positions.



Use two independent input devices for muting inputs. Failure to do so may cause the MUTING state due to a single muting sensor's failure.



Install the switch to activate the Override function in a location that provides a clear view of the entire hazardous zone and where it cannot be activated from within the hazardous zone. Make sure that nobody is in the hazardous zone before activating the Override function.



Make sure to connect an override cancel switch to the RESET line when using the Override function. Otherwise, the OVERRIDE state may not be released by the override cancel switch, resulting in serious injury.



If a meeting error occurred while a workpiece blocks F3SG, you can use either of the following ways to remove the workpiece:

- 1) manually (with additional safety measures), or
 - 2) Override function (override under normal operation or on startup)
- You must use either of the above ways. You **MUST NOT** use both ways.

Using both ways may activate the Override function at an unintended timing for a worker.

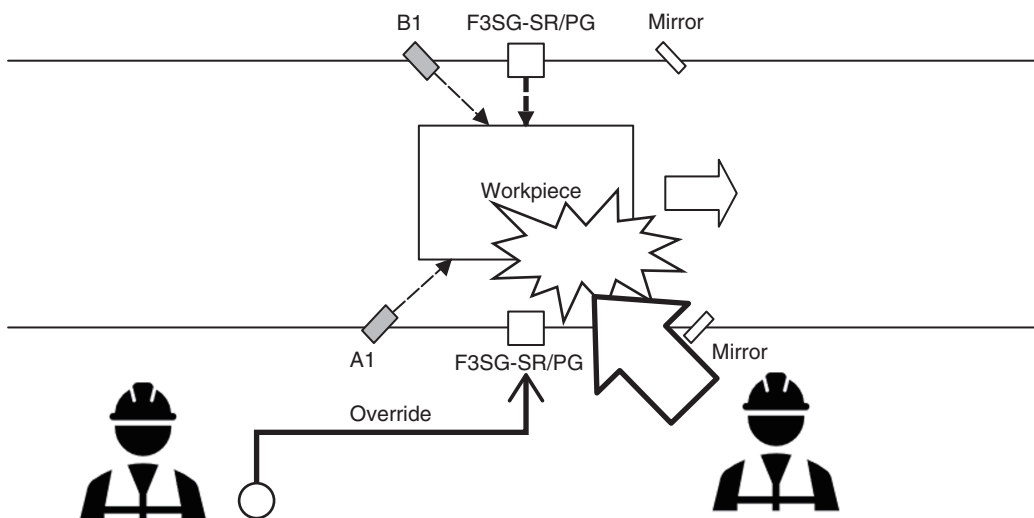

Install the F3SG-SR/PG so that it is not affected by reflective surfaces. Failure to do so may hinder detection, resulting in serious injury. For an installation distance from reflective surfaces, see 5-1-3. *Distance from Reflective Surfaces*.



When using more than one set of F3SG-SR/PG's in adjacent areas, the emitter of one F3SG-SR/PG may interfere with the receiver of the other, causing the safety functions to stop working properly. Install, configure and maintain them so that mutual interference does not occur.



To change the response time, calculate the safety distance based on the setting. Otherwise, the machine may not stop before a person reaches the hazardous part, resulting in serious injury.



Do not use the F3SG-SR/PG with mirrors in a retro-reflective configuration. Doing so may hinder detection. It is possible to use mirrors to alter the detection zone to a 90-degree angle.

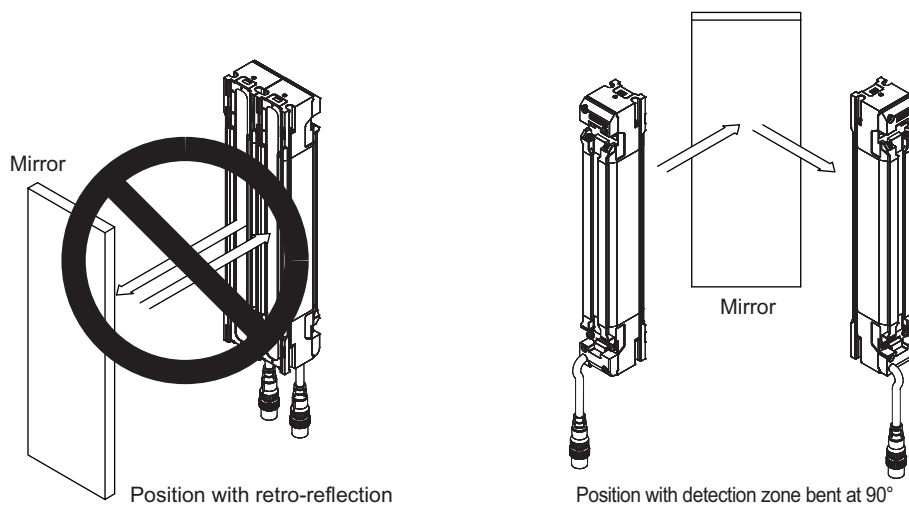

Wiring

⚠ WARNING

When using the PNP output, connect the load between the output and 0 V line. When using the NPN output, connect the load between the output and +24 VDC line. Connecting the load between the output and a different power supply line from the above line will result in a dangerous condition because the operation mode of safety outputs are reversed to "Dark-ON".



When using the PNP output, do not ground +24 VDC line. When using the NPN output, do not ground 0 V line. Otherwise, a ground fault may turn the safety outputs ON, resulting in a failure of stopping the machine.



Configure the system by using the optimal number of safety outputs that satisfy the requirements of the necessary safety category.



Do not connect each line of the F3SG-SR/PG to a DC power supply of higher than 24 VDC+20%. Also, do not connect it to an AC power supply. Failure to do so may result in electric shock.



Make sure to perform wiring while the power supply is OFF.



Do not use the output signal of the auxiliary output or IO-Link output for safety applications. Failure to do so may result in serious injury when the F3SG-SR/PG fails.



For the F3SG-SR/PG to comply with IEC 61496-1 and UL 508, the DC power supply unit must satisfy all of the following conditions:



- The DC power supply operates within the rated power voltage (24 VDC \pm 20%).
- The DC power supply has tolerance against the total rated current of devices if it is connected to multiple devices.
- The DC power supply complies with EMC directives (industrial environment).
- Double or reinforced insulation is applied between the primary and secondary circuits.
- The DC power supply has an automatic recovery type of overcurrent protection characteristics.
- Output holding time is 20 ms or longer.
- The DC power supply satisfies output characteristic requirements for class 2 circuit or limited voltage current circuit defined by UL 508. Refer to 5-4-2. *Power Supply Unit*.
- The DC power supply complies with laws and regulations, regarding EMC and electrical equipment safety, of the country or region where the F3SG-SR/PG is used. (For example, in EU, the power supply must comply with the EMC Directive and the Low Voltage Directive.)

Double or reinforced insulation from hazardous voltage must be applied to all input and output lines. Failure to do so may result in electric shock.



Extension of the cable must be within a specified length. If it isn't, safety functions may not work properly, resulting in danger.



Settings

WARNING

Make sure the Responsible Person tests the operation of the F3SG-SR/PG after setting with the DIP Switch on the F39-SGIT-IL3, Teach-in, SD Manager 3 or End Cap to verify that the F3SG-SR/PG operates as intended. Make sure to stop the machine until the test is complete. Unintended settings may cause a person to go undetected, resulting in serious injury.



When performing the Backup, make sure to set the DIP Switch Position 1 at OFF (Unlock) before turning on the power. If the DIP Switch Position 1 is at ON (Lock), the Restoration is performed, which may case the settings of the F3SG-SR/PG to be overwritten and a person to go undetected, resulting in serious injury.



When performing the Restoration, make sure to set the DIP Switch Position 1 at ON (Lock) before turning on the power. If the DIP Switch Position 1 at OFF (Unlock), the Backup is performed, which may cause the settings of the F39-SGIT-IL3 to be overwritten and a person to go undetected, resulting in serious injury.



When the Restoration is performed, if the DIP Switch Position 2 is at ON (DIP Switch Enabled) and settings of the DIP Switch Positions 3 to 8 are different from the backup data in the F39-SGIT-IL3, the settings in the DIP Switch takes priority and are saved in the F3SG-SR/PG. To prevent such an accident, it is recommended that you set the DIP Switch Position 2 at OFF before performing the Restoration when you use the settings backed up from the F3SG-SR/PG or make settings with the SD Manager 3.



When pairing your device with the F39-SGBT Bluetooth® Communication Unit, make sure that the model name and serial number of the sensor to be configured match the information on your device.



Do not use the F39-SGBT Bluetooth® Communication Unit in close proximity to medical equipment such as a pacemaker. Radio wave may affect the operation of such equipment.



Security Measures

WARNING

Anti-virus protection

Install the latest commercial-quality antivirus software on the computer connected to the control system and maintain to keep the software up-to-date.



Security measures to prevent unauthorized access

Take the following measures to prevent unauthorized access to our products.

- Install physical controls so that only authorized personnel can access control systems and equipment.
- Reduce connections to control systems and equipment via networks to prevent access from untrusted devices.
- Install firewalls to shut down unused communications ports and limit communications hosts and isolate control systems and equipment from the IT network.
- Use a virtual private network (VPN) for remote access to control systems and equipment.
- Adopt multifactor authentication to devices with remote access to control systems and equipment.
- Set strong passwords and change them frequently.
- Scan virus to ensure safety of USB drives or other external storages before connecting them to control systems and equipment.



Data input and output protection

Validate backups and ranges to cope with unintentional modification of input/output data to control systems and equipment.

- Checking the scope of data
- Checking validity of backups and preparing data for restore in case of falsification and abnormalities
- Safety design, such as emergency shutdown and fail-soft operation in case of data tampering and abnormalities



Data recovery

Backup data and keep the data up-to-date periodically to prepare for data loss.



When using an intranet environment through a global address, connecting to an unauthorized terminal such as a SCADA, HMI or to an unauthorized server may result in network security issues such as spoofing and tampering.

You must take sufficient measures such as restricting access to the terminal, using a terminal equipped with a secure function, and locking the installation area by yourself.



When constructing an intranet, communication failure may occur due to cable disconnection or the influence of unauthorized network equipment.

Take adequate measures, such as restricting physical access to network devices, by means such as locking the installation area.



When using a device equipped with the SD Memory Card function, there is a security risk that a third party may acquire, alter, or replace the files and data in the removable media by removing the removable media or unmounting the removable media.

Please take sufficient measures, such as restricting physical access to the Controller or taking appropriate management measures for removable media, by means of locking the installation area, entrance management, etc., by yourself.



To prevent computer viruses, install antivirus software on a computer where you use this software.

Make sure to keep the antivirus software updated.



Keep your computer's OS updated to avoid security risks caused by a vulnerability in the OS.



Always use the highest version of this software to add new features, increase operability, and enhance security.



Manage usernames and passwords carefully to protect them from unauthorized uses.



Set up a firewall (E.g., disabling unused communication ports, limiting communication hosts, etc.) on a network for a control system and devices to separate them from other IT networks. Make sure to connect to the control system inside the firewall.



Use a virtual private network (VPN) for remote access to a control system and devices.



Other

 **WARNING**

Perform daily and 6-month inspections for all F3SG-SR/PG as described in *Chapter 7 Checklists*. When using the F3SG-SR/PG in cascade connection, perform inspections for every connected F3SG-SR/PG. Otherwise, the system may fail to work properly, resulting in serious injury.



Do not try to disassemble, repair, or modify the product. Doing so may cause the safety functions to stop working properly.



Do not use the product in environments where flammable or explosive gases are present. Doing so may result in explosion.



Do not use the F3SG-SR in environments where strong electromagnetic field may be produced. Doing so may cause the safety functions to stop working properly.



Precautions for Safe Use

Make sure to observe the following precautions that are necessary for ensuring safe use of the product.

- Do not install, use, or store the product in the following types of environments:
 - Areas exposed to intense interference light, such as direct sunlight
 - Areas with high humidity where condensation is likely to occur
 - Areas where corrosive gases are present
 - Areas exposed to vibration or shock levels higher than in the specification provisions
 - Areas where the pollution degree is harsher than 3, such as outdoor environment
 - Areas where the product may get wet with liquid that can solve adhesive
- When carrying and installing the product, make sure that two people work together according to the weight of the product so that it should not fall. Otherwise injury and/or property damage may occur.
- The rated life of the LEDs used for this product is 6 years.
- Loads must satisfy both of the following conditions:
 - Not short-circuited
 - Not used with a current that is higher than the rating
- Make sure that the mounting brackets, fixing screws and connectors are properly secured with the torque recommended in this document.
- Bending radii of cables must be equal to or higher than specified minimum values.
- When replacing the cables with those other than the dedicated cables, use cable connectors that provide a protection grade of IP54 or higher, for the cables..
- To extend a cable length with a cable other than the dedicated cable, use a cable with the same or superior specifications.



Refer to 5-4-3-11. *Extending Cable Length with Commercially Available Cable*

- Be sure to route the input/output lines for the F3SG-SR/PG separate from high-potential power lines or through an exclusive conduit.
- Make sure that foreign material such as water, oil, or dust does not enter the F3SG-SR/PG, F39-SGIT-IL3 or the connector while the end cap and root cables of the F3SG-SR/PG or the cover of the DIP Switch on the F39-SGIT-IL3 is removed.
- Make sure that foreign material such as water, oil, or dust does not enter the F39-SGBT or the connector while the F39-SGBT is not connected to the F39-SGIT-IL3.
- The F39-SGIT-IL3 is dedicated to the F3SG-SR/PG series. Do not use it for equipment other than F3SG-SR/PG series.
- In environments where foreign material such as spatter adheres to the F3SG-SR/PG, attach a cover to protect the F3SG-SR/PG from the spatter.
- Some cutting oils may affect the product. Before using cutting oils, make sure that the oils should not cause deterioration or degradation of the product.
- Do not use the product with degraded protective structure such as swelling and crack in housing and/or sealing components. Otherwise cutting oil or other substance may enter the product, resulting in a risk of corruption or burning.
- Use the F39-JG□C-□ Root-Straight Cables, F39-JGR3K-□ Root-Plug Cables for Extended or F39-JGR3K-□□□ Conversion Cables and/or F39-JGR3W Cascading Cables for Extended or F39-JGR12L Side-by-side Cascading Cables in environment where the product may be exposed to oil. Using the other cables in such an environment may cause cutting oils or other substances to enter the cables, resulting in a risk of damaging or burning the product.
- Do not connect the Conversion Cable for the following purposes. Failure to do so may result in failure.
 1. Connecting with the F39-SGIT-IL3, F39-GCNY2 or F39-GCNY3
 2. Connecting between the F3SG-SR's
- Dispose of the product in accordance with the relevant rules and regulations of the country or area where the product is used.

Precautions for Correct Use

Observe the precautions described below to prevent operation failure, malfunctions, or undesirable effects on product performance.

■ Storage conditions and installation environment

- Do not install, use, or store the product in the following types of environments:
 - Areas with a temperature or humidity out of the specified range
 - Areas submerged in water or subject to rain water
- This is a class A product (for industrial environments). In residential areas it may cause radio interference, in which case the Responsible Person may be required to take adequate measures to reduce interference.
- Use the sensor after water droplets have been removed when water droplets such as condensation have adhered to the optical surface of the sensor.

■ Wiring and installation

- Properly perform the wiring after confirming the signal names of all the terminals.
- Do not operate the control system until 3 s or more after turning ON the power of the F3SG-SR/PG.
- When using a commercially available switching regulator power supply, make sure to ground the PE terminal (protective earth terminal).
- Install the emitter and receiver, emitter/receiver, and passive mirror to the same vertical direction.
- Use brackets of specified quantities and locations according to the dimensions. If the brackets described above are not used, ratings and performance cannot be met.
- Do not install the F3SG-SR/PG close to a device that generates high-frequency noise. Otherwise, take sufficient blocking measures.
- Sharing the power supply with other devices may cause the F3SG-SR/PG to be affected by noise or voltage drop. It is recommended that the F3SG-SR/PG use a power supply dedicated for safety components, not shared with other devices.
- Do not change the scan code during normal operation. The F3SG-SR/PG transitions to lockout.
- Do not apply load to the connectors.
- When attached with the spatter protection cover, the operating range of the F3SG-SR and F3SG-PGA-L/-A safety light curtain is 10% shorter than the rating and that of the F3SG-PGA-C is 20% shorter than the rating. In addition, the operating range of the IP69K model is about 20% lower than that of the standard model. Install the product in consideration with the decrease of the operating range.

■ Cleaning

- Do not use thinner, benzene, or acetone for cleaning. They affect the product's resin parts and paint on the housing.
- Use a soft cloth which is dry or wetted with clean water for cleaning. Do not use solvents.

■ Object detection

- The F3SG-SR cannot detect transparent and/or translucent objects.

■ Settings

- Do not operate the DIP Switch on the F39-SGIT-IL3 during normal operation of the F3SG-SR/PG. Otherwise, the F3SG-SR/PG enters the LOCKOUT state.
- Do not operate the DIP Switch and Push Switch on the F39-SGIT-IL3 with tools that may damage the product.
- Be sure that the F3SG-SR/PG is in the SETTING state when making a change to the setting.

 For more information on the SETTING state, refer to ■ *SETTING State* under 2-2-1. *Operating States of F3SG-SR/PG and Intelligent Tap*.

■ Bluetooth® wireless technology

- The F39-SGBT Bluetooth® Communication Unit uses radio band of 2.4 GHz. The use of the product in close proximity to the following examples of radio interference sources may cause radio interference with the product, resulting in loss of or slow connection. Check the radio wave environment in your site before installing the F39-SGBT.

Examples:

- Medical equipment such as a pacemaker
 - RFID premises radio stations (license required) used in factory manufacturing lines
 - Specified low power radio station
 - Wireless LAN device
- When you use a PC or smartphone for Bluetooth® communication with the F39-SGBT, the transmission distance may be shorter depending on structures of premises or obstructions. The transmission may be interrupted especially by reinforced concrete.
 - Use the product within the line of sight of 10 m.
 - Use the product in conjunction with a Bluetooth device. It is not guaranteed that the product can communicate with all Bluetooth devices.

Visual Aids

The following symbols appear in this document to help you locate different types of information.



Indicates important information or advice on a function or operation of the product.



Indicates page numbers or chapter title of related information.

Table of Contents

Legislation and Standards	i
Terms and Conditions Agreement	iii
Terms and Conditions Agreement (Software)	v
Safety Precautions	vi
Precautions for Safe Use	xiv
Precautions for Correct Use	xv
Visual Aids	xvii
Chapter1 Overview and Specifications	1
1-1. What is Included	2
1-2. System Components	3
1-3. List of Key Features	6
1-3-1. Model Overview	6
1-3-2. List of Key Features	8
1-4. LED Indicators on F3SG-SR/PG	10
1-5. Ratings and Specifications	15
1-5-1. F3SG-SR Series	15
1-5-2. F3SG-PG Series	20
1-5-3. F3SG-SR IP69K Model	24
1-5-4. Intelligent Tap	29
1-5-5. Bluetooth® Communication Unit	30
1-6. List of Models	31
1-6-1. List of Models and Response Times	31
1-6-1-1. F3SG-SR	31
1-6-1-2. F3SG-PG Series	34
1-6-1-3. F3SG-SR IP69K Model	35
1-6-2. List of Models, Current Consumption and Weight	36
1-6-2-1. F3SG-SR	36
1-6-2-2. F3SG-PG Series	40
1-6-2-3. F3SG-SR IP69K Model	40
1-6-3. Calculation of Response Time of Cascaded Segments	42
Chapter2 System Operation and Functions	45
2-1. Combination of Functions	47
2-2. Operating States	49
2-2-1. Operating States of F3SG-SR/PG and Intelligent Tap	49
2-2-2. Operating States of Intelligent Tap	50
2-3. Mutual Interference Prevention	51
2-3-1. Mutual Interference Prevention of F3SG-SR/PG	51

2-3-1-1. Optical Synchronization	51
2-3-1-2. Wired Synchronization	54
2-4. PNP/NPN Selection	55
2-4-1. Overview	55
2-4-2. Setting with Intelligent Tap	55
2-4-3. Setting with SD Manager 3	55
2-5. Self-Test	56
2-5-1. Overview	56
2-5-1-1. Self-Test details	56
2-5-1-2. Waveform of safety outputs	57
2-6. External Test	58
2-6-1. Overview	58
2-6-2. Factory Default Setting	59
2-6-3. Setting with Intelligent Tap	59
2-6-4. Setting with SD Manager 3	59
2-7. Lockout Reset	60
2-8. Interlock	61
2-8-1. Overview	61
2-8-2. Factory Default Setting	63
2-8-3. Setting with Intelligent Tap	63
2-8-4. Setting with SD Manager 3	63
2-9. Pre-Reset	64
2-9-1. Overview	64
2-9-2. Factory Default Setting	65
2-9-3. Setting with Intelligent Tap	66
2-9-4. Setting with SD Manager 3	66
2-10. PSDI	67
2-10-1. Overview	67
2-10-2. Factory Default Setting	69
2-10-3. Setting Change using Intelligent Tap	69
2-10-4. Setting Change using SD Manager 3	69
2-11. External Device Monitoring (EDM)	70
2-11-1. Overview	70
2-11-2. Factory Default Setting	71
2-11-3. Setting with Intelligent Tap	71
2-11-4. Setting with SD Manager 3	72
2-12. Auxiliary Output	73
2-12-1. Overview	73
2-12-2. Factory Default Setting	74
2-12-3. Setting with Intelligent Tap	74
2-12-4. Setting with SD Manager 3	75
2-13. Muting	77

2-13-1.Overview	77
2-13-2.Standard Muting Mode	79
2-13-2-1. Overview	79
2-13-2-2. Installation Example 1 of Standard Muting Mode (Using Two Muting Sensors)	82
2-13-3.Exit-Only Muting Mode	89
2-13-3-1. Overview	89
2-13-3-2. Installation Example of Exit-Only Muting Mode	91
2-13-4.Position Detection Muting Mode	94
2-13-4-1. Overview	94
2-13-4-2. Installation Example of Position Detection Muting Mode	96
2-13-5.Dynamic Muting	98
2-13-6.Factory Default Setting	99
2-13-7.Setting with Intelligent Tap	99
2-13-8.Setting with SD Manager 3	99
2-14. Override	101
2-14-1.Overview	101
2-14-2.Override at Normal Operation	103
2-14-3.Override upon Startup	106
2-14-4.Setting with Intelligent Tap	107
2-14-5.Setting with SD Manager 3	107
2-15. Fixed Blanking	108
2-15-1.Overview	108
2-15-2.Factory Default Setting	112
2-15-3.Setting with Intelligent Tap	113
2-15-4.Setting with SD Manager 3	113
2-16. Floating Blanking	114
2-16-1.Overview	114
2-16-2.Factory Default Setting	118
2-16-3.Setting with Intelligent Tap	118
2-16-4.Setting with SD Manager 3	118
2-17. Reduced Resolution	119
2-17-1.Overview	119
2-17-2.Factory Default Setting	120
2-17-3.Setting with Intelligent Tap	120
2-17-4.Setting with SD Manager 3	121
2-18. Warning Zone	122
2-18-1.Overview	122
2-18-2.Factory Default Setting	125
2-18-3.Setting with Intelligent Tap	125
2-18-4.Setting with SD Manager 3	125
2-19. Setting Zone Adjacency Conditions	126
2-19-1.Zone Adjacency Condition	126

2-19-2.Zone Overlap Condition	126
2-20. Operating Range Selection	128
2-20-1.Overview	128
2-20-2.Factory Default Setting	129
2-20-3.Setting with Intelligent Tap	129
2-20-4.Setting with SD Manager 3	129
2-21. Response Time Adjustment	130
2-21-1.Overview	130
2-21-2.Factory Default Setting	130
2-21-3.Setting with Intelligent Tap	130
2-21-4.Setting with SD Manager 3	130
2-22. Area Beam Indicator (ABI)	131
2-22-1.Overview	131
2-22-2.Factory Default Setting	132
2-22-3.Setting Change using Intelligent Tap	132
2-22-4.Setting Change using SD Manager 3	132
2-23. Designated Beam Output	134
2-23-1.Overview	134
2-23-2.Factory Default Setting	134
2-23-3.Setting with Intelligent Tap	134
2-23-4.Setting with SD Manager 3	135
2-24. Stable Light Threshold Adjustment	136
2-24-1.Overview	136
2-24-2.Factory Default Setting	136
2-24-3.Setting Change using Intelligent Tap	136
2-24-4.Setting Change using SD Manager 3	136
2-25. Incident/Ambient Light Level Monitoring	137
2-25-1.Incident Light Level Information	137
2-25-1-1. Overview	137
2-25-1-2. Setting with SD Manager 3	137
2-25-2.Ambient Light Level Information	137
2-25-2-1. Overview	137
2-25-2-2. Setting with SD Manager 3	137
2-26. Lamp	138
2-26-1.Functional Description	138
2-26-2.Installation to Main Unit	139
2-26-3.Factory Default Setting	139
2-26-4.Setting with Intelligent Tap	139
2-26-5.Setting with SD Manager 3	139
2-27. Maintenance Information	142
2-27-1.Overview	142
2-27-2.Error Log	142

2-27-3.Warning Log	142
2-27-4.Power-ON Time	143
2-27-5.Load Switching Frequency	143
2-27-6.Muting Statistics Information	144
2-27-7.Intelligent Tap Log	144
2-28. Operating Status Monitoring	145
2-28-1.Overview	145
2-28-2.Readout Information	145
2-29. Instantaneous Block Detection	146
2-29-1.Overview	146
2-29-2.Factory Default Setting	146
2-29-3.Setting Change using Intelligent Tap	146
2-29-4.Setting Change using SD Manager 3	146
2-30. Setting Recovery	147
2-31. Backup/Restoration	148
2-31-1.Overview	148
2-31-2.Factory Default Setting	148
2-31-3.Setting Change using Intelligent Tap	148
2-31-4.Setting Change using SD Manager 3	148
2-32. IO-Link	149
Chapter3 Setting with Intelligent Tap	151
3-1. List of Functions Configurable by Intelligent Tap and Initial Setup Method	153
3-1-1. Functions Configurable by Intelligent Tap	153
3-1-2. Initial Setup Method after Purchase	153
3-2. Connection	154
3-3. Wiring	157
3-4. LED Indicators on Intelligent Tap	158
3-5. DIP Switch on Intelligent Tap	159
3-6. Backup/Restoration	161
3-6-1. Description of Functions	161
3-6-2. Performing Backup	162
3-6-3. Performing Restoration	164
3-6-4. Various Usage of Backup and Restoration	168
3-6-4-1. Plug and Work	168
3-6-4-2. Copy and Paste of Sensor Settings	168
3-6-4-3. Changing F3SG-SR/PG Configuration to Connect to Intelligent Tap	168
3-6-4-4. Changing F3SG-SR/PG's Settings with Intelligent Tap DIP Switch	168
3-7. Teach-in (Fix Blanking / Floating Blanking)	169
3-7-1. Setting Fixed Blanking by Teach-in	169
3-7-2. Setting Floating Blanking by Teach-in	174

3-8. Connection to SD Manager 3	178
3-9. IO-Link	179
3-9-1. Functional Description	179
3-9-2. Communication Specifications	179
3-9-3. Process Data	179
3-9-4. Service Data	182
3-10. Intelligent Tap Application Example	186
3-10-1. Setting F3SG-SR/PG with DIP Switch	186
3-10-2. Saving Sensor Setting to Intelligent Tap Using Backup Function	188
3-10-3. Applying Setting Saved in Intelligent Tap to Sensor Using Restoration	190
3-10-4. Replacing Intelligent Tap	193
3-10-4-1. Setting with DIP-SW	193
3-10-4-2. Settings Configured by Setup Information Stored in Intelligent Tap	195
Chapter4 Setting with SD Manager 3	199
4-1. Overview and Specifications	202
4-1-1. Overview of Configuration Tool	202
4-1-2. System Environment	203
4-1-2-1. PC Environment	203
4-1-2-2. Smartphone Environment	203
4-1-3. Connection Method to Use Configuration Tools	204
4-1-3-1. Connection Patterns of F3SG-SR/PG, Intelligent Tap, and Each Device	204
4-1-3-2. Connection Procedure When Using USB Connector	207
4-1-3-3. Connection Procedure When Using Bluetooth® Communication Unit (F39-SGBT)	208
4-1-4. SETTING State of F3SG-SR/PG with SD Manager 3 Connected	212
4-2. Basic Operation of SD Manager 3	214
4-2-1. How to Install/Uninstall SD Manager 3	214
4-2-1-1. Downloading SD Manager 3	214
4-2-1-2. Installing SD Manager 3	214
4-2-1-3. How to Uninstall SD Manager 3	216
4-2-1-4. Installing Driver of Intelligent Tap	217
4-2-2. How to Update SD Manager 3	217
4-2-3. Getting Started, Description on Top Page and Each Button, and Shutting Down	217
4-2-3-1. Getting Started	217
4-2-3-2. Description on Top Page and Each Button	218
4-2-3-3. Displaying/Hiding Docked Windows	220
4-2-3-4. Shutting Down	220
4-2-4. Starting SD Manager 3 Offline	221
4-2-4-1. Creating New Configuration File	221
4-2-4-2. Reading Configuration from PC	222
4-2-4-3. Saving New Configuration File to PC	222

4-2-4-4. Switching Offline to Online	222
4-2-5. Logging In/Logging Out	223
4-2-5-1. Logging In	223
4-2-5-2. Logging Out	225
4-2-6. Password Protection	226
4-2-6-1. Access Restriction	226
4-2-6-2. Changing Password	226
4-2-6-3. Forgot the Password?	226
4-2-6-4. Confirming Lot No. of Intelligent Tap	226
4-2-6-5. Resetting the Initial Password to "0000"	227
4-2-7. Reading/Saving/Writing Configuration of Intelligent Tap	228
4-2-7-1. Reading Configuration from Intelligent Tap	228
4-2-7-2. Saving Configuration of Intelligent Tap in PC	228
4-2-7-3. Writing Configuration into Intelligent Tap	229
4-2-8. Viewing Current Configuration	231
4-2-9. Safety Distance Calculation	232
4-3. Changing Settings with SD Manager 3	233
4-3-1. Preparing to Change Settings	233
4-3-2. I/O Settings	234
4-3-2-1. Interlock/External Device Monitoring (EDM)/PSDI	234
4-3-2-2. Reset Input Time	235
4-3-2-3. Teach-in Input	236
4-3-2-4. External Test Input	237
4-3-3. Auxiliary Output/Lamp Setting	238
4-3-3-1. Auxiliary Output/Lamp	238
4-3-3-2. Designated Beam Output	240
4-3-3-3. Area Beam Indicator (ABI)	243
4-3-4. Safety Function Setting	245
4-3-4-1. Fixed Blanking	245
4-3-4-2. Floating Blanking	248
4-3-4-3. Muting/Override	250
4-3-4-4. Pre-Reset	255
4-3-4-5. Reduced Resolution	256
4-3-4-6. Warning Zone	257
4-3-4-7. PSDI	259
4-3-5. Operating State Setting	260
4-3-5-1. Response Time Change	260
4-3-5-2. Stable Light Threshold Adjustment	261
4-3-5-3. Operating Range Selection	262
4-3-6. Setting Initialization	263
4-3-6-1. Initializing F3SG-SR/PG Settings	263
4-3-6-2. Initializing Settings of Intelligent Tap (F39-SGIT-IL3)	264

4-3-7. Backup/Restoration	265
4-4. Monitoring with SD Manager 3	266
4-4-1. Monitoring	266
4-4-1-1. Incident Light/Ambient Light	266
4-4-1-2. Operating Status Monitoring	268
4-4-2. Muting Statistics Information	270
4-4-3. Maintenance Information	274
4-4-3-1. Error Log Information	274
4-4-3-2. Warning Log	276
4-4-3-3. Intelligent Tap Log	277
4-4-3-4. Power-On Time/Load Switching Frequency	278
4-4-3-5. Instantaneous Block Detection Information	280
4-5. Basic Operation of SD Manager 3 Mobile APP	281
4-5-1. How to Install/Uninstall SD Manager 3 Mobile APP	281
4-5-1-1. Installing SD Manager 3 Mobile APP	281
4-5-1-2. Uninstalling SD Manager 3 Mobile APP	281
4-5-2. How to Update SD Manager 3 Mobile APP	281
4-5-3. Pairing (Connection Verification)	281
4-5-4. Getting Started, Main Screen, Version Confirmation, and Shutting Down	282
4-5-4-1. Getting Started	282
4-5-4-2. Main Screen	284
4-5-4-3. Version Information	285
4-5-4-4. Shutting Down	286
4-5-5. Monitoring with SD Manager 3	287
4-5-5-1. Incident/Ambient Light Level Monitoring	287
4-5-5-2. Status Monitoring Information	288
4-5-5-3. Maintenance Information	290
4-6. SD Manager 3 Application Example	292
4-6-1. Changing F3SG-SR/PG settings using SD Manager 3	292
4-6-2. Reading out F3SG-SR/PG settings using SD Manager 3	295
4-6-3. Monitoring F3SG-SR/PG status using SD Manager 3	298
4-6-4. Changing settings and/or monitoring status of multiple F3SG-SR/PG setting/status using one Intelligent Tap and SD Manager 3 300	
Chapter5 Wiring and Installation	303
5-1. Installation Considerations	306
5-1-1. Detection Zone and Approach	306
5-1-2. Safety Distance	308
5-1-2-1. Safety Distance Formulas according to ISO 13855/EN ISO 13855	308
5-1-2-2. Safety Distance Formulas according to ANSI B11.19	312
5-1-3. Distance from Reflective Surfaces	313

5-1-3-1. F3SG-SR/PG (Type 2 ESPE)	313
5-1-4. Mutual Interference Prevention	314
5-2. Dimensions	315
5-2-1. F3SG-SR Series	315
5-2-1-1. Mounted with Side-Mount Brackets (Intermediate Brackets) (F39-LSGF)	315
5-2-1-2. Mounted with Adjustable Side-Mount Brackets (Intermediate Brackets) (F39-LSGA)	317
5-2-1-3. Mounted with Adjustable Top/Bottom Brackets (F3SJ, F3SN Adapter) (F39-LSGTB-SJ) and Side-Mount Brackets (Intermediate Brackets) (F39-LSGF)	319
5-2-1-4. Mounted with Adjustable Top/Bottom Brackets (F3SJ, F3SN Adapter) (F39-LSGTB-SJ) and Adjustable Side-Mount Brackets (Intermediate Brackets) (F39-LSGA)	321
5-2-2. F3SG-PG Series	323
5-2-2-1. Mounted with Side-Mount Brackets (Intermediate Brackets) (F39-LSGF)	323
5-2-2-2. Mounted with Adjustable Side-Mount Brackets (Intermediate Brackets) (F39-LSGA)	325
5-2-2-3. Mounted with Adjustable Top/Bottom Brackets (F3SJ, F3SN Adapter) (F39-LSGTB-SJ) and Side-Mount Bracket (Intermediate Bracket) (F39-LSGF)	327
5-2-2-4. Mounted with Adjustable Top/Bottom Brackets (F3SJ, F3SN Adapter) (F39-LSGTB-SJ) and Adjustable Side-Mount Bracket (Intermediate Bracket) (F39-LSGA)	329
5-2-3. Bracket	331
5-2-3-1. Side-Mount Bracket (Intermediate Bracket) (F39-LSGF sold, separately)	331
5-2-3-2. Adjustable Side-Mount Bracket (Intermediate Bracket) (F39-LSGA, sold separately)	331
5-2-3-3. Adjustable Top/Bottom Bracket (F3SJ, F3SN Adapter) (F39-LSGTB-SJ, sold separately)	331
5-2-3-4. Adjustable Top/Bottom Bracket (F3SG-RA/RE Adapter) (F39-LSGTB-RE, sold separately)	332
5-2-3-5. Adjustable Top/Bottom Bracket (MS4800, F3SR Adapter) (F39-LSGTB-MS, sold separately)	332
5-2-4. Intelligent Tap	333
5-2-5. Intelligent Tap Bracket	333
5-2-6. Bluetooth® Communication Unit	335
5-2-7. Spatter Protection Cover	336
5-2-8. Laser Alignment Pointer	337
5-2-9. Lamps	338
5-2-10. Muting Sensor Arm Mounter	339
5-2-11. Floor Mounting Column	340
5-2-12. Mirror Columns	342
5-2-13. IP69K Model	344
5-3. Mounting	346
5-3-1. Mounting Method	346
5-3-2. Number of Brackets Required	346
5-3-3. Proper Mounting	347
5-3-3-1. Proper Mounting Orientation	347
5-3-4. Mounting Procedure	349
5-3-4-1. Mounting with Side-Mount Brackets (Intermediate Brackets)	

(F39-LSGF)	349
5-3-4-2. Mounting with Adjustable Side-Mount Brackets (Intermediate Brackets) (F39-LSGA)	350
5-3-4-3. Mounting with Adjustable Top/Bottom Brackets (F3SJ, F3SN Adapter) (F39-LSGTB-SJ) and Side-Mount Brackets (Intermediate Brackets) (F39-LSGF)	354
5-3-4-4. Mounting with Adjustable Top/Bottom Brackets (F3SJ, F3SN Adapter) (F39-LSGTB-SJ) and Adjustable Side-Mount Brackets (Intermediate Brackets) (F39-LSGA)	358
5-3-4-5. Mounting IP69K Model	363
5-3-5. Beam Alignment Procedure	366
5-4. Wiring	367
5-4-1. Wiring Precautions	367
5-4-2. Power Supply Unit	368
5-4-3. Cable Connections	369
5-4-3-1. Root-Straight Cable	371
5-4-3-2. Root-Plug Cable for Extended	372
5-4-3-3. Extended Socket-Straight Cable	373
5-4-3-4. Extended Plug-Socket Cable	374
5-4-3-5. Cascading Cable for Extended	376
5-4-3-6. Side-by-side Cascading Cable	377
5-4-3-7. F3SJ-A/B Conversion Cable	378
5-4-3-8. F3SG-RE Conversion Cable	380
5-4-3-9. MS48 Conversion Cable	381
5-4-3-10. F3SJ-A/B-TS/T, F3SG-RA-TS Conversion Cable	382
5-4-3-11. Extending Cable Length with Commercially Available Cable	383
5-4-3-12. Reduced Wiring Connector System with Y-Joint Plug/Socket Connector	384
5-4-3-13. Easy Wiring Connector System with Reset Switch Connector	385
5-4-3-14. Reduced Wiring System with Muting Connector Box	387
5-4-3-15. Wiring of IP69K Model	389
5-4-3-16. Intelligent Tap-to-IO-Link Master Cable	390
5-4-4. Functional Earth Connection	391
5-5. Cascade Connection	392
5-5-1. Overview	392
5-5-2. Connection Procedure	394
Chapter6 Input/Output Circuit and Applications	397
6-1. Input/Output Circuit	398
6-1-1. Entire Circuit Diagram	398
6-1-1-1. F3SG-SR and F3SG-PGA-A/L	398
6-1-1-2. F3SG-PGA-C	399
6-1-2. Input Circuit Diagram by Function	400
6-2. Wiring Examples (for F3SG-SR/PG)	401
6-2-1. Non-Muting System Wiring Examples	401
6-2-1-1. Auto Reset Mode with Optical Synchronization and EDM Unused	401

6-2-1-2. Auto Reset Mode with Wired Synchronization and EDM Unused	403
6-2-1-3. Auto Reset Mode with Optical Synchronization and EDM Used	404
6-2-1-4. Manual Reset Mode with EDM	405
6-2-1-5. Manual Reset Mode with EDM and Y-Joint Plug/Socket Connector	406
6-2-1-6. Manual Reset Mode with Intelligent Tap	407
6-2-1-7. Manual Reset Mode with Reset Switch Connector	408
6-2-1-8. Pre-Reset Mode with EDM Unused	409
6-2-1-9. Pre-Reset Mode with Reset Switch Connector	410
6-2-1-10. Single Break with EDM and Intelligent Tap	411
6-2-1-11. Double Break with EDM	412
6-2-2. Muting System Wiring Examples	413
6-2-2-1. Standard Muting Mode/Exit-Only Muting Mode	413
6-2-2-2. Standard Muting Mode/Exit-Only Muting Mode with Y-Joint Plug	414
6-2-2-3. Standard Muting Mode/Exit-Only Muting Mode with Intelligent Tap	415
6-2-2-4. Standard Muting Mode/Exit-Only Muting Mode with Reset Switch Connector	416
6-3. Connectable Safety Controllers	417
Chapter7 Checklists	419
7-1. Pre-Operation Checklists	420
7-1-1. Checklists	420
7-1-1-1. Installation Condition Check	420
7-1-1-2. Wiring Check Before Power Is Turned ON	420
7-1-1-3. Operation Check While the Machine Is Stopped	421
7-1-1-4. Checking that Hazardous Parts Stop While the Machine Operates	422
7-2. Maintenance Checklists	423
7-2-1. Checklists	423
7-2-1-1. Inspection at Startup and When Changing Operators	423
7-2-1-2. Checking that Hazardous Parts Stop While the Machine Operates	424
7-2-1-3. Items to Inspect Every 6 Months or When Machine Settings Are Changed	424
Chapter8 Appendix	427
8-1. Troubleshooting	428
8-1-1. LED Indicators	428
8-1-2. LOCKOUT State	430
8-1-2-1. Description	430
8-1-2-2. Troubleshooting	431
8-1-3. Warning	437
8-1-3-1. Description	437
8-1-3-2. Troubleshooting	437
8-1-3-3. Muting Sequence Error Indication	438

8-1-3-4. Interlock Sequence Error Indication	439
8-1-3-5. PSDI Sequence Error Indication	440
8-1-4. Troubleshooting for Intelligent Tap	441
8-1-5. Troubleshooting for Bluetooth® Communication Unit	444
8-2. Optional Accessories (Sold Separately)	445
8-3. Glossary	457
8-4. Revision History	461

Chapter 1 Overview and Specifications

1-1. What is Included	2
1-2. System Components	3
1-3. List of Key Features	6
1-3-1. Model Overview	6
1-3-2. List of Key Features	8
1-4. LED Indicators on F3SG-SR/PG	10
1-5. Ratings and Specifications	15
1-5-1. F3SG-SR Series	15
1-5-2. F3SG-PG Series	20
1-5-3. F3SG-SR IP69K Model	24
1-5-4. Intelligent Tap	29
1-5-5. Bluetooth® Communication Unit	30
1-6. List of Models	31
1-6-1. List of Models and Response Times	31
1-6-2. List of Models, Current Consumption and Weight	36
1-6-3. Calculation of Response Time of Cascaded Segments	42

1-1. What is Included

Before use, confirm that the items below are included with the product.

If you find that an item is missing, please contact your Omron representative.

■ F3SG-SR series

- Emitter × 1
- Receiver × 1
- End Cap (for switching Scan Code Selection function) × 2 (End cap for Scan Code B is included.)
- Instruction Sheet x 7
- Quick Installation Manual x 3
- Troubleshooting Guide Sticker x 2
- Warning Zone Label x 1

■ F3SG-PGA-A/L

- Emitter x 1
- Receiver x 1
- End cap (for scan code switching) x 2 (for scan code B included)
- Instruction Sheet x 7
- Quick Installation Manual x 3
- Troubleshooting Sticker x 2

■ F3G-PGA-C

- Emitter/Receiver x 1
- Passive Mirror x 1
- End cap (for scan code switching) x 1 (for scan code B included)
- Instruction Sheet x 7
- Quick Installation Manual x 3
- Troubleshooting Sticker x 2

■ F3SG-SR IP69K Model

- Emitter x 1
- Receiver x 1
- Instruction Sheet x 7
- Quick Installation Manual x 3
- Troubleshooting Sticker x 2

1-2. System Components

This section describes the system components and part names of the F3SG-SR/PG system.

■ F3SG-SR and F3SG-PG-A/L

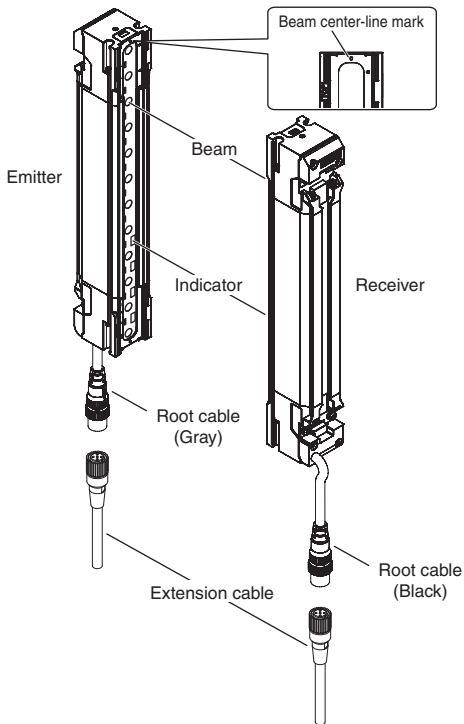

Marking on the side (Emitter)

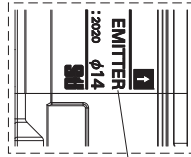

"EMITTER" mark

Marking on the side (Receiver)

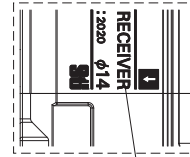

"RECEIVER" mark

Functional earth terminal on backside

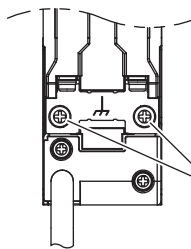

Functional earth terminal



CHECK!

- The marking "EMITTER" is on the side of emitter. And the marking "RECEIVER" is on the side of receiver.
- The color of functional earth terminal screws is silver for the emitter and black for the receiver.

■ F3SG-PGA-C

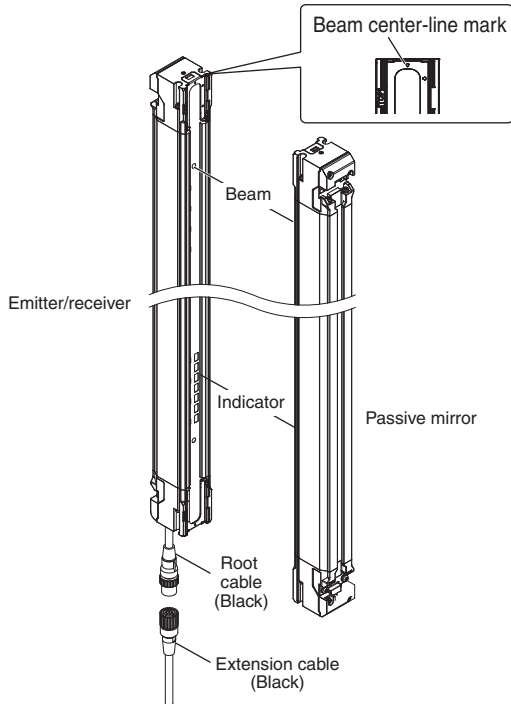

Marking on the side (Emitter/Receiver)

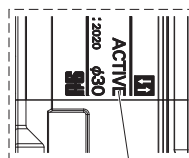

"ACTIVE" mark

Marking on the side (Passive mirror)

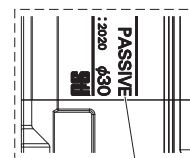

"PASSIVE" mark

Functional earth terminal on backside

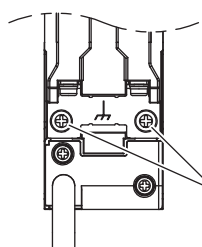

Functional earth terminal



CHECK!

- The marking "ACITVE" is on the side of emitter/receiver. And the marking "PASSIVE" is on the side of passive mirror.
- The functional earth terminal is on emitter/receiver only. The color of the screws is black.

■ F3SG-SR IP69K Model

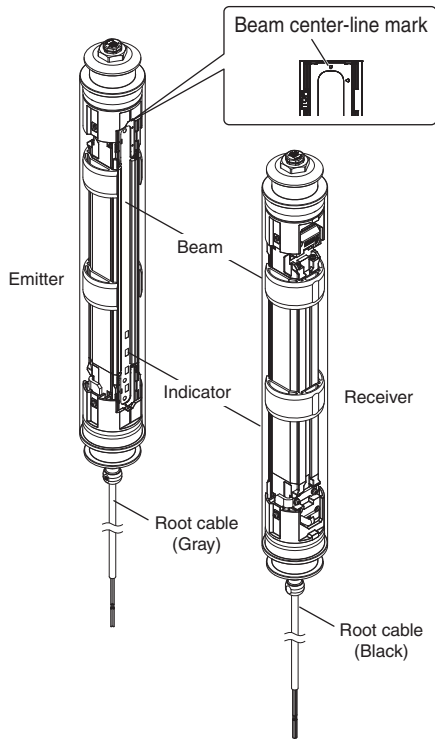

Marking on the side (Emitter)

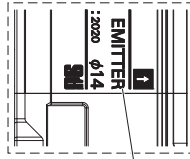

"EMITTER" mark

Marking on the side (Receiver)

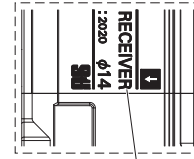

"RECEIVER" mark



CHECK!

· The functional earth terminal cannot be used on F3SG-SR-K.

1-3. List of Key Features

1-3-1. Model Overview

The F3SG-SR/PG series is a safety light curtain intended to be used for humans protection.

■ F3SG-SR Series

The F3SG-SR series has two sub-series, F3SG-SRA and F3SG-SRB. Both are safety light curtains comprising an emitter and a receiver.

The F3SG-SRA is a full-featured model having advanced functionality. The F3SG-SRB is a standard model, yet it supports wide variety of functionality. The F3SG-SR series is suitable for finger, arm, leg and body detection.

■ F3SG-PG Series

The F3SG-PG series has three (3) variations: F3SG-PGA-A, F3SG-PGA-L. and F3SG-PGA-C.

F3SG-PGA-A and F3SG-PGA-L are safety multi-light beam consisting of an emitter and a receiver, and F3SG-PGA-C consisting of an emitter/receiver and a passive mirror.

F3SG-PGA-A is a model with the operating range equivalent to that of the F3SG-SR series. F3SG-PG-L is a model with the operating range of 70 m for long-distance applications. F3SG-PG-C is a reduced-wire model. F3SG-PG series can be used for tripping.

■ Intelligent Tap (F39-SGIT-IL3, sold separately)

The following setting functions are available by connecting the Intelligent Tap to the F3SG-SR/PG.

- (1) Setting with DIP Switch *1
- (2) Setting with SD Manager 3 by connecting the Intelligent Tap to a PC *1
- (3) Wireless communication with PC or smartphone by connecting the Intelligent Tap and Bluetooth® Communication Unit (F39-SGBT, sold separately)
- (4) IO-Link communication by connecting the Intelligent Tap and IO-Link Master
- (5) Backup and Restoration of settings *2

*1. Refer to  1-3-2. List of Key Features for more information on configurable functions.

*2. Refer to  Chapter 3 Setting with Intelligent Tap for more information on the Backup and Restoration.

(1)

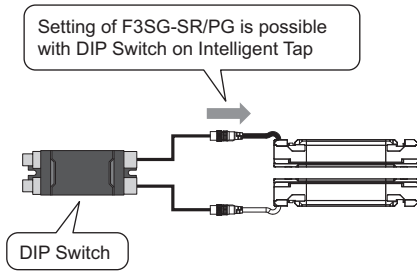

(2)

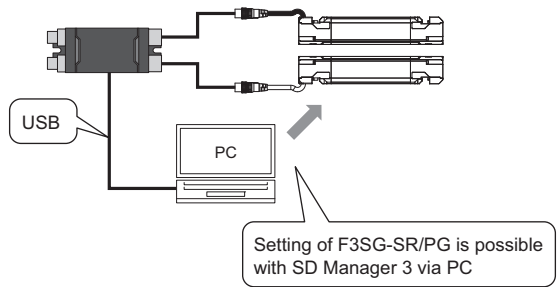

(3)

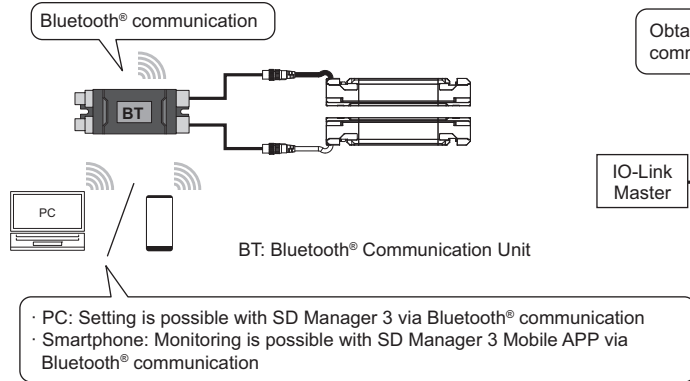

(4)

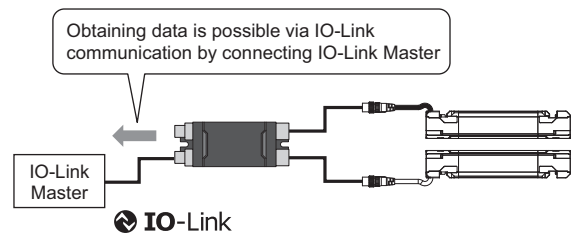

(5)

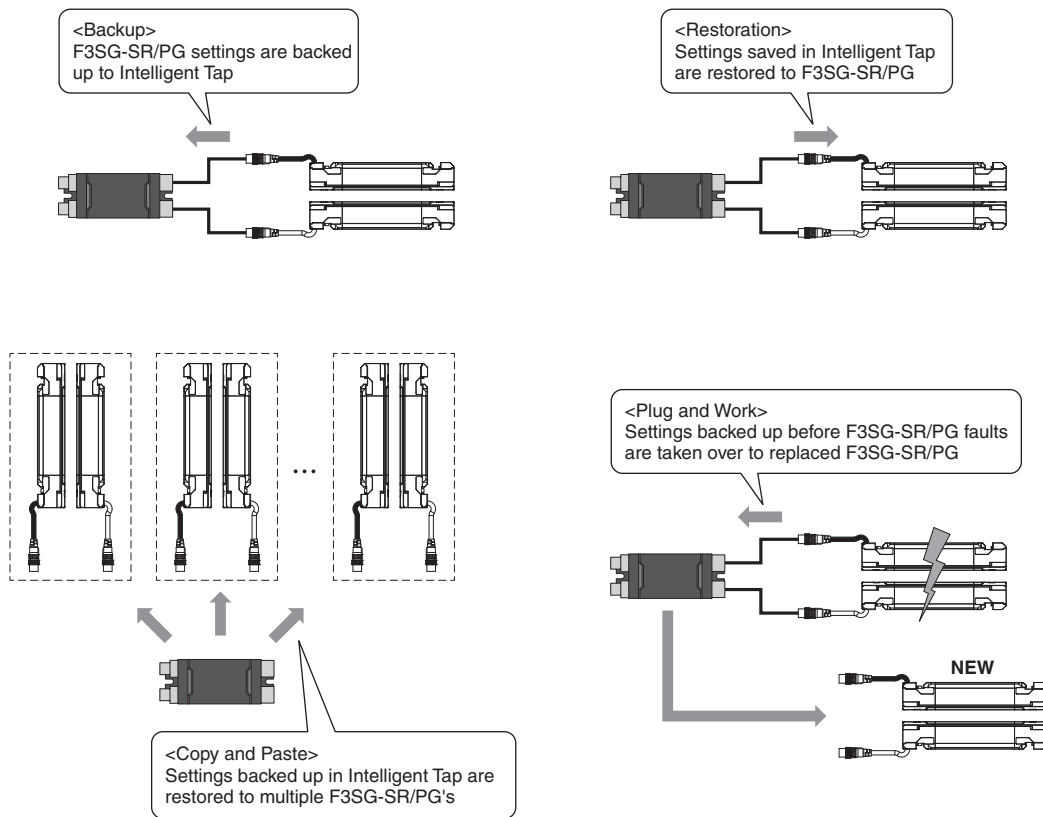

1-3-2. List of Key Features

The F3SG-SR/PG has the following features. Some of the features are available or configurable by the Intelligent Tap (F39-SGIT-IL3) or the SD Manager 3 (PC configuration tool). Sensor status monitoring is available by the SD Manager 3 Mobile APP, which is the configuration tool for smartphones.

Feature	Availability						Setting/Monitoring by					Factory default setting	Page
	F3SG-SRA	F3SG-SRB	F3SG-PG-A	F3SG-PG-L	F3SG-PG-C	F3SG-SRB-K	Sensor		Intelligent Tap	PC	Smartphone		
							Wiring	End Cap	DIP Switch *1	SD Manager 3	SD Manager 3 Mobile APP *2		
Mutual Interference Prevention	X	X	X	X	X	X *6	X *3	X *4	-	-	-	Code A *4	p.51
PNP/NPN Selection	X	X	X	X	X	X	X	-	-	-	-	-	p.55
External Test	X	X	X	X	X	X	X	-	-	-	-	-	p.58
Interlock	X	X	X	X	X	X	-	-	X	X	-	Start/Restart Interlock Disabled (Auto Reset)	p.61
Pre-Reset	X	X	X	X	X	X	-	-	X	X	-	Disabled	p.64
PSDI	X	X	-	-	-	X	-	-	-	X	-	Disabled	p.67
External Device Monitoring (EDM)	X	X	X	X	X	X	-	-	X	X	-	Disabled	p.70
Auxiliary Output	X	X	X	X	X	X	-	-	-	X	-	Safety output information (Inverted signal output: Enabled)	p.73
Muting	X	X	X	X	X	X	-	-	-	X	-	Enabled (Standard Muting)	p.77
Override	X	X	X	X	X	X	-	-	-	X	-	Enabled	p.101
Fixed Blanking	X	X	-	-	-	X	-	-	X	X	-	Disabled	p.108
Floating Blanking	X	X	-	-	-	X	-	-	X	X	-	Disabled	p.114
Reduced Resolution	X	X	-	-	-	X	-	-	-	X	-	Disabled	p.119
Warning Zone	X	X	-	-	-	-	-	-	-	X	-	Disabled	p.122
Operating Range Selection	X	X	-	X	-	X	X	-	X	X	-	Long *5	p.128
Response Time Adjustment	X	X	X	X	X	X	-	-	-	X	-	Normal	p.130
Area Beam Indicator (ABI)	X	-	X	X	X	-	-	-	-	X	-	Block/Unblock information	p.131
Designated Beam Output	X	X	X	X	X	X	-	-	-	X	-	Disabled	p.134
Stable Light Threshold Adjustment	X	X	X	X	X	X	-	-	-	X	-	170%	p.136
Light Level Monitoring/ Interference Light Display	X	X	X	X	X	X	-	-	-	X	X	-	p.137
Maintenance Information	X	X	X	X	X	X	-	-	-	X	X	-	p.142
Operating Status Monitoring	X	X	X	X	X	X	-	-	-	X	X	-	p.145
Instantaneous Block Detection Information	X	- *7	X	X	X	-	-	-	-	X	-	Enabled	p.146

Feature	Availability						Setting/Monitoring by					Factory default setting	Page
	F3SG-SRA	F3SG-SRB	F3SG-PG-A	F3SG-PG-L	F3SG-PG-C	F3SG-SRB-K	Sensor		Intelligent Tap	PC	Smartphone		
							Wiring	End Cap	DIP Switch *1	SD Manager 3	SD Manager 3 Mobile APP *2		
Backup/Restoration	X	X	X	X	X	X	-	-	-	X	-	Enable (Backup: Manual Operation, Restoration: Auto Operation)	p.148

*1. DIP Switch is on the F39-SGIT-IL3 Intelligent Tap.

*2. The F39-SGIT-IL3 Intelligent Tap is necessary to use the SD Manager 3 or SD Manager 3 Mobile APP.

*3. Mutual interference can be prevented by Optical Synchronization or Wired Synchronization.

*4. Mutual interference can be prevented by Scan Code Selection.

*5. In the case of setting by DIP Switch or SD Manager 3. For the setting by wiring, it is selectable from the Long and Short modes.

*6. Mutual interference prevention with an end cap is not supported. The scan code is fixed to A.

*7. F3SG-SRB does not record oscillation.

1-4. LED Indicators on F3SG-SR/PG

■ F3SG-SR Series

<Emitter>

F3SG-□SR□□□□□□-14

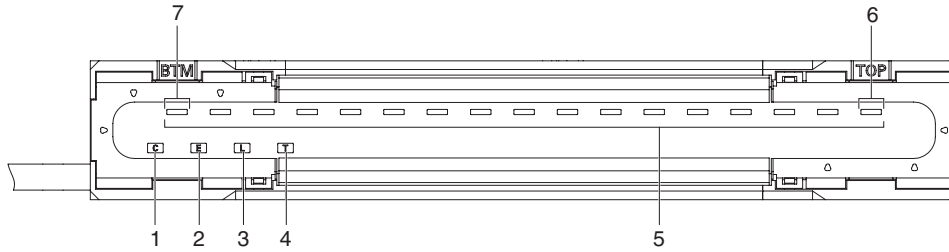

F3SG-□SR□□□□□□-25/-45/-85

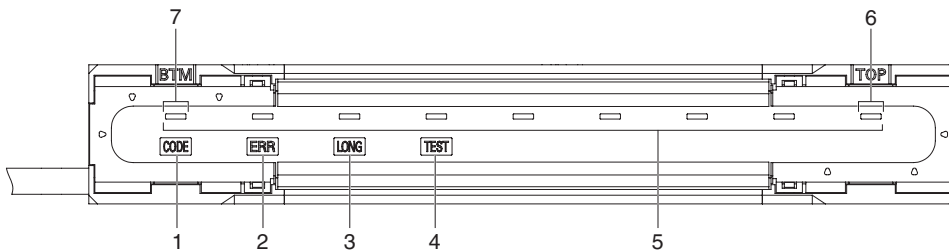

<Receiver>

F3SG-□SR□□□□□□-14

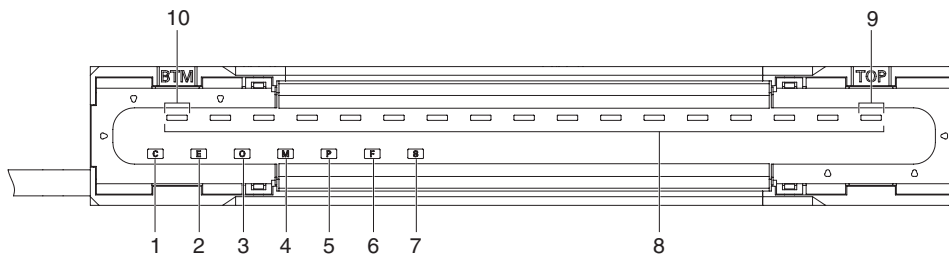

F3SG-□SR□□□□□□-25/-45/-85

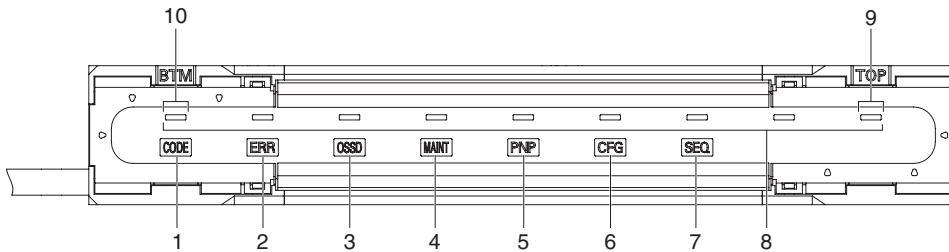

■ F3SG-PG Series

<Emitter>
 F3SG-4PGA□□□□-□A/□L

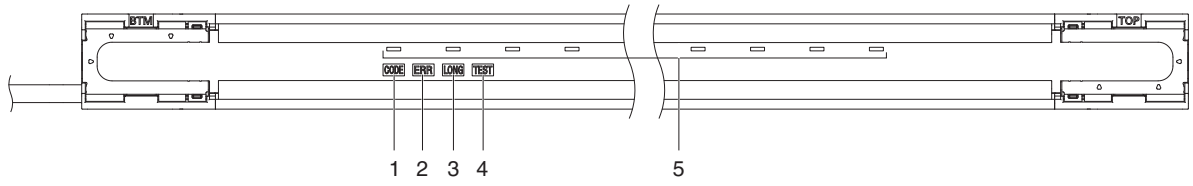

<Receiver, Emitter/Receiver>
 F3SG-4PGA□□□□-□A/□L/□C

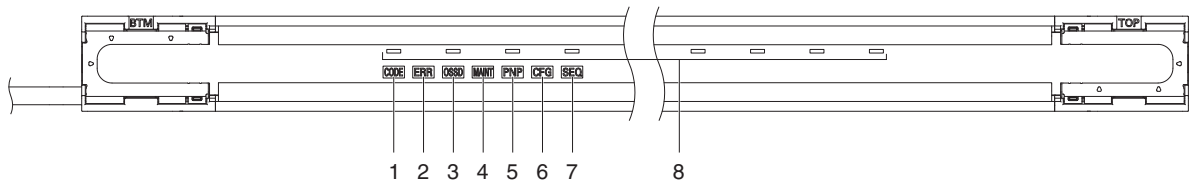

Shown below are indication statuses of the LED indicators on the F3SG-SR/PG when you purchased.

■ Emitter (F3SG-SR, F3SG-PGA-A/L)

Location	Indicator	Name	Color	Illuminated	Blinking	F3SG-SRA	F3SG-SRB	F3SG-PGA-A	F3SG-PGA-L
1	<div style="border: 1px solid black; padding: 2px; display: inline-block; text-align: center;">C</div> or <div style="border: 1px solid black; padding: 2px; display: inline-block; text-align: center;">CODE</div>	Scan code	Green	Code A is selected	-	X	X	X	X
			Orange	Code B is selected					
			OFF	Automatic interference prevention by wired synchronization being performed					
2	<div style="border: 1px solid black; padding: 2px; display: inline-block; text-align: center;">E</div> or <div style="border: 1px solid black; padding: 2px; display: inline-block; text-align: center;">ERR</div>	Lockout	Red	LOCKOUT state. The indicator is illuminated in the emitter of another sensor segment than that having a lockout error (when in cascade connection or between the emitter and receiver in the Wired Synchronization)	LOCKOUT state. The indicator is illuminated in the emitter of a sensor segment having a lockout error	X	X	X	X
3	<div style="border: 1px solid black; padding: 2px; display: inline-block; text-align: center;">L</div> or <div style="border: 1px solid black; padding: 2px; display: inline-block; text-align: center;">LONG</div>	Operating range	Green	Long Mode is selected	-	X	X	-	X
			OFF	Short Mode is selected					
4	<div style="border: 1px solid black; padding: 2px; display: inline-block; text-align: center;">T</div> or <div style="border: 1px solid black; padding: 2px; display: inline-block; text-align: center;">TEST</div>	Test	Yellow	-	External Test is being performed	X	X	X	X
5	-	Area Beam Indicator (ABI) (*1)	Green	The target beams of the ABI are unblocked and the safety outputs are turned ON	MUTING or OVERRIDE state. In the MUTING state, only the ABI indicators in the muting zone are blinking. Or the target beams of the ABI are blocked instantaneously	X	-	X	X
			Orange	Incident light level of the target beams of the ABI is 170% (factory default setting (*2)) or less of ON-threshold	Incident light level of the target beams of the ABI is 170% (factory default setting (*2)) or less of ON threshold and 5 to 10 s elapsed. Or one muting input becomes the ON state and the MUTING state has not been started yet, or one muting input becomes the OFF state and the other is not in the OFF state yet. (*3)				
			Red	The target beams of the ABI are blocked	LOCKOUT state due to Cap error or Other sensor error (*4), or LOCKOUT state due to DIP Switch setting error (*5 *6)				
			OFF	The target beams of the ABI are unblocked (The ABI then will be illuminated in green when the safety outputs are turned ON.)	-				
6	TOP	Top-beam-state (*1)	Blue	The top beam is unblocked	MUTING/OVERRIDE state, or LOCKOUT state due to Cap error or Other sensor error	-	X	-	-
7	BTM	Bottom-beam-state (*1)	Blue	The bottom beam is unblocked	MUTING/OVERRIDE, or LOCKOUT state due to DIP Switch setting error (*6)	-	X	-	-

*1. The indicator of the emitter is illuminated only in the case the Wired Synchronization is enabled and is off in the case the Optical Synchronization is enabled.

*2. Configurable by SD Manager 3.

*3. This is the case for the Standard Muting mode. For other muting modes, refer to "2-13. Muting".

*4. The Area Beam Indicator closer to the "TOP" mark on the F3SG-SR blinks.

*5. The Area Beam Indicator closer to the "BTM" mark on the F3SG-SR blinks.

*6. DIP switches is on the Intelligent Tap.

■ Receiver (F3SG-SR, F3SG-PGA-A/L) and Emitter/Receiver (F3SG-PGA-C)

Location	Indicator	Name	Color	Illuminated	Blinking	F3SG-SRA	F3SG-SRB	F3SG-PG
1	C or CODE	Scan code	Green	Code A is selected	-	X	X	X
			Orange	Code B is selected				
			OFF	Automatic interference prevention by wired synchronization being performed				
2	E or ERR	Lockout	Red	LOCKOUT state. The indicator is illuminated in the receiver of another sensor segment than that having a lockout error (when in cascade connection or between the emitter and receiver in the Wired Synchronization)	LOCKOUT state. The indicator is illuminated in the receiver of a sensor segment having a lockout error	X	X	X
3	O or OSSD	ON/OFF	Green	Safety outputs are in ON state	-	X	X	X
			Red	Safety outputs are in OFF state	LOCKOUT state due to Safety output error, or error due to abnormal power supply or noise	X	X	X
4	M or MAINT	Maintenance	Red	LOCKOUT state due to a recoverable error (When in cascade connection, the indicator of only the sensor segment having the error is illuminated)	LOCKOUT state due to a replacement-recommended error (When in cascade connection, the indicator of only the sensor segment having the error blinks)	X	X	X
			Orange	Safety outputs are instantaneously turned OFF due to ambient light, vibration or noise. Or sequence error in Muting, Pre-Reset or PSDI	Intelligent Tap is in the LOCKOUT state	X	X	X
5	P or PNP	PNP/NPN mode	Green	PNP is configured	Polarity of PNP is changed to NPN, or vice versa, during operation, and internal circuit is defective	X	X	X
			OFF	NPN is configured	-			
6	F or CFG	Configuration	Green	Fixed or Floating Blanking, Reduced Resolution, Warning Zone or Slow mode of Response Time Adjustment is enabled. Or after the Muting zone is determined by the Dynamic Muting function.	TEACH-IN mode, zone measurement being performed by Dynamic Muting, or LOCKOUT state due to Blanking monitoring error, Configuration error or Parameter error	X	X	X
7	S or SEQ	Sequence	Yellow	INTERLOCK state	Sequence or sequence error in Muting, Pre-Reset or PSDI (*1) or Teach-in error	X	X	X

Location	Indicator	Name	Color	Illuminated	Blinking	F3SG-SRA	F3SG-SRB	F3SG-PG
8	-	Area Beam Indicator (ABI)	Green	The target beams of the ABI are unblocked and the safety outputs are turned ON	MUTING or OVERRIDE state. In the MUTING state, only the ABI indicators in the muting zone are blinking. Or the target beams of the ABI are blocked instantaneously	X	-	
			Orange	Incident light level of the target beams of the ABI is 170% (factory default setting (*2)) or less of ON-threshold	Incident light level of the target beams of the ABI is 170% (factory default setting (*2)) or less of ON threshold and 5 to 10 s elapsed. Or one muting input becomes the ON state and the MUTING state has not been started yet, or one muting input becomes the OFF state and the other is not in the OFF state yet. (*3)			
			Red	The target beams of the ABI are blocked	LOCKOUT state due to Cap error or Other sensor error (*4), or LOCKOUT state due to DIP Switch setting error (*5 *6)			
			OFF	The target beams of the ABI are unblocked (The ABI then will be illuminated in green when the safety outputs are turned ON.)	-			
9	TOP	Top-beam-state	Blue	The top beam is unblocked	MUTING/OVERRIDE state, or LOCKOUT state due to Cap error or Other sensor error	-	X	
10	BTM	Bottom-beam-state	Blue	The bottom beam is unblocked	MUTING/OVERRIDE state, or LOCKOUT state due to DIP Switch setting error (*6)	-	X	

- *1. Refer to 8-1. *Troubleshooting* for more information on blinking patterns.
- *2. Configurable by SD Manager 3.
- *3. This is the case for the Standard Muting mode. For other muting modes, refer to 2-13. *Muting*.
- *4. The Area Beam Indicator closer to the "TOP" mark on the F3SG-SR blinks.
- *5. The Area Beam Indicator closer to the "BTM" mark on the F3SG-SR blinks.
- *6. DIP switches is on the Intelligent Tap.



In the SETTING state to make settings with the SD Manager 3, the TEST, LONG and CODE indicators on the emitter and the CFG, PNP and CODE indicators on the receiver blink.
(TEST: Yellow, LONG/CODE: Green, CFG/PNP/CODE: Green)

CHECK!

For more information on the statuses of the LED indicators in the SETTING state, refer to 4-1-4. *SETTING State of F3SG-SR/PG with SD Manager 3 Connected.*

1-5. Ratings and Specifications

⚠ WARNING



Extension of the cable must be within a specified length. If it isn't, safety functions may not work properly, resulting in danger.









1-5-1. F3SG-SR Series



The □□□□ in the model names indicate the protective heights in millimeters.

Model		F3SG-□□RA□□□□-14 F3SG-□□RB□□□□-14	F3SG-□□RA□□□□-25 F3SG-□□RB□□□□-25	F3SG-□□RA□□□□-45 F3SG-□□RB□□□□-45	F3SG-□□RA□□□□-85 F3SG-□□RB□□□□-85	
Performance	Object resolution (Detection capability)	Opaque objects				
		14-mm dia.	25-mm dia.	45-mm dia.	85-mm dia.	
	Beam gap	10 mm	20 mm	40 mm	80 mm	
	Number of beams	15 to 199	8 to 124	6 to 38	4 to 12	
	Lens size	4.4 × 3.4 mm (W × H)		6.7 × 4.5 mm (W × H)		
	Protective height	160 to 2,000 mm	160 to 2,480 mm	240 to 1,520 mm	280 to 920 mm	
	Operating range	Long	0.3 to 10.0 m *		0.3 to 20.0 m	
		Short	0.3 to 3.0 m *		0.3 to 7.0 m	
	* When operating at an ambient temperature of -10 to -30°C, use the F3SG-SR with the operating range of 0.3 to 5.0 m in Long Mode and 0.3 to 1.5 m in Short Mode.					
	Response time *1	Normal mode	ON to OFF	Optical synchronization: 8 to 18 ms Wired synchronization: 10 to 21 ms	Optical synchronization: 8 to 13 ms Wired synchronization: 10 to 17 ms	Optical synchronization: 8 ms Wired synchronization: 10 ms
OFF to ON			Optical synchronization: 40 to 90 ms Wired synchronization: 50 to 105 ms	Optical synchronization: 40 to 65 ms Wired synchronization: 50 to 85 ms	Optical synchronization: 40 ms Wired synchronization: 50 ms	
×2 Slow mode *2		ON to OFF	Optical synchronization: 16 to 36 ms Wired synchronization: 20 to 42 ms	Optical synchronization: 16 to 26 ms Wired synchronization: 20 to 34 ms	Optical synchronization: 16 ms Wired synchronization: 20 ms	
		OFF to ON	Optical synchronization: 80 to 180 ms Wired synchronization: 100 to 210 ms	Optical synchronization: 80 to 130 ms Wired synchronization: 100 to 170 ms	Optical synchronization: 80 ms Wired synchronization: 100 ms	
×4 Slow mode *2		ON to OFF	Optical synchronization: 32 to 72 ms Wired synchronization: 40 to 84 ms	Optical synchronization: 32 to 52 ms Wired synchronization: 40 to 68 ms	Optical synchronization: 32 ms Wired synchronization: 40 ms	
		OFF to ON	Optical synchronization: 160 to 360 ms Wired synchronization: 200 to 420 ms	Optical synchronization: 160 to 260 ms Wired synchronization: 200 to 340 ms	Optical synchronization: 160 ms Wired synchronization: 200 ms	

Model		F3SG-□SRA□□□□-14 F3SG-□SRB□□□□-14	F3SG-□SRA□□□□-25 F3SG-□SRB□□□□-25	F3SG-□SRA□□□□-45 F3SG-□SRB□□□□-45	F3SG-□SRA□□□□-85 F3SG-□SRB□□□□-85	
	×8 Slow mode *2	ON to OFF	Optical synchronization: 64 to 144 ms Wired synchronization: 80 to 168 ms	Optical synchronization: 64 to 104 ms Wired synchronization: 80 to 136 ms	Optical synchronization: 64 ms Wired synchronization: 80 ms	
		OFF to ON	Optical synchronization: 320 to 720 ms Wired synchronization: 400 to 840 ms	Optical synchronization: 320 to 520 ms Wired synchronization: 400 to 680 ms	Optical synchronization: 320 ms Wired synchronization: 400 ms	
	*1. Response time when used in one segment system.  See 1-6-1. List of Models and Response Times for more information. *2. Selectable by SD Manager 3.					
	Effective aperture angle (EAA) (IEC 61496-2)	Type 4	±2.5° max. *			
		Type 2	±5.0° max. *			
			*Emitter and receiver at operating range of 3 m or greater			
	Light source		Infrared LEDs, Wavelength: 870 nm			
	Startup waiting time		3 s max.			
	Electrical	Power supply voltage (Vs)		SELV/PELV 24 VDC±20% (ripple p-p 10% max.)		
		Current consumption		 See 1-6. List of Models for more information.		
Safety outputs (OSSD)		Two PNP or NPN transistor outputs (PNP or NPN is selectable by wiring of power supply.) Load current: 300 mA max., Residual voltage: 2 V max. (except for voltage drop due to cable extension), Capacitive load: 1 µF max., Inductive load: 2.2 H max. *1 *2 *3 Leakage current: 1 mA max.(PNP), 2 mA max.(NPN) *4 *1. For the F3SG-□SRA, the load current is 150 mA max. in 2-segment cascade and 80 mA max. in 3-segment cascade. *2. The residual voltage is 3 V max. when the Intelligent Tap is connected to the sensor. *3. The load inductance is the maximum value when the safety output frequently repeats ON and OFF. When you use the safety output at 4 Hz or less, the usable load inductance becomes larger. *4. These values must be taken into consideration when connecting elements including a capacitive load such as a capacitor.				
Auxiliary output		One PNP or NPN transistor output (PNP or NPN is selectable by wiring of power supply.) Load current: 100 mA max., Residual voltage: 2 V max. * * The residual voltage is 3 V max. when the Intelligent Tap is connected to the sensor.				
Output operation mode		Safety output		Light-ON (Safety outputs are turned to the ON state when the receiver receives an emitting signal.)		
	Auxiliary output		Safety output (Inverted signal output: Enable) (default) (Configurable by SD Manager 3)			

Model		F3SG-□SRA□□□□-14 F3SG-□SRB□□□□-14	F3SG-□SRA□□□□-25 F3SG-□SRB□□□□-25	F3SG-□SRA□□□□-45 F3SG-□SRB□□□□-45	F3SG-□SRA□□□□-85 F3SG-□SRB□□□□-85	
	Input voltage	TEST	Light emission stops when connected to 24 VDC ON voltage: Vs-3 V to Vs (short circuit current: approx. 5.0 mA) * OFF voltage: 0 V to 1/2 Vs, or open (short circuit current: approx. 6.0 mA) * Light emission stops when connected to 0 V ON voltage: 0 to 3 V (short circuit current: approx. 6.0 mA) OFF voltage: 1/2 Vs to Vs, or open (short circuit current: approx. 5.0 mA) *			
		OPERATING RANGE SELECT INPUT	Long: 12 V to Vs (short circuit current: approx. 4.2 mA) * or open Short: 0 to 3 V (short circuit current: approx. 4.2 mA)			
		RESET/EDM	PNP ON voltage: Vs-3 V to Vs (short circuit current: approx. 9.5 mA) * OFF voltage: 0 V to 1/2 Vs, or open (short circuit current: approx. 13.0 mA) * NPN ON voltage: 0 to 3 V (short circuit current: approx. 13.0 mA) OFF voltage: 1/2 Vs to Vs, or open (short circuit current: approx. 9.5 mA) *			
		MUTE A/B, PRE-RESET, PSDI	PNP ON voltage: Vs-3 V to Vs (short circuit current: approx. 4.5 mA) * OFF voltage: 0 V to 1/2 Vs, or open (short circuit current: approx. 7.0 mA) * NPN ON voltage: 0 to 3 V (short circuit current: approx. 7.0 mA) OFF voltage: 1/2 Vs to Vs, or open (short circuit current: approx. 4.5 mA) *			
	*The Vs indicates a supply voltage value in your environment.					
	Overvoltage category (IEC 60664-1)		II			
	Indicators		 See ■ F3SG-SR Series for more information.			
	Protective circuit		Output short-circuit protection			
	Insulation resistance		20 MΩ or higher (500 VDC megger)			
	Dielectric strength		1,000 VAC, 50/60 Hz (1 min)			
Functional	Mutual interference prevention	Optical synchronization by Scan Code: in up to 2 sets Wired synchronization: in up to 3 sets  See 5-1-4. <i>Mutual Interference Prevention</i> for more information.				
	Cascade connection	Number of cascaded segments: 3 max. Total number of beams: 255 max.				
	Test function	Self-test (at power-on, and during operation) External test (light emission stop function by test input)				
	Safety-related functions	Interlock External Device Monitoring (EDM) Pre-Reset PSDI Fixed Blanking/Floating Blanking Reduced Resolution Muting/Override Mutual Interference Prevention PNP/NPN Selection Response Time Adjustment  See Chapter 2 <i>System Operation and Functions</i> and Chapter 3 <i>Setting with Intelligent Tap</i> for more information.				



Model			F3SG-□SRA□□□□-14 F3SG-□SRB□□□□-14	F3SG-□SRA□□□□-25 F3SG-□SRB□□□□-25	F3SG-□SRA□□□□-45 F3SG-□SRB□□□□-45	F3SG-□SRA□□□□-85 F3SG-□SRB□□□□-85
Environmental	Ambient temperature	Operating	-30 to 55 °C (non-icing)			
		Storage	-30 to 70 °C			
	Ambient humidity	Operating	35% to 85% (non-condensing)			
		Storage	35% to 95%			
	Ambient illuminance		Incandescent lamp: 3,000 lx max. on receiver surface Sunlight: 10,000 lx max. on receiver surface			
	Degree of protection (IEC 60529)		IEC 60529: IP65 and IP67, JIS C 0920 Annex 1: IP67G			
	Vibration resistance (IEC 61496-1)		Class 3M4 (IEC TR 60721-4-3) Operation limit: 5~150Hz, Multiple amplitude of 7 mm, Acceleration of 1G, 10 sweeps each in X, Y, and Z directions (no delay at resonant frequencies)			
	Shock resistance (IEC 61496-1)		Class 3M4 (IEC TR 60721-4-3) Operation limit: Acceleration of 15G, Pulse duration of 6ms, 100 shocks for each in X, Y, and Z directions (600 shocks in total)			
Pollution degree (IEC 60664-1)		3				
Connections	Root cable	Type of connection	To sensors: dedicated connector, To external: M12 connector type (5-pin emitter and 8-pin receiver) or open-ended type IP67 and IP67G (JIS C 0920 Annex 1) * rated when mated. * The F3SG-SR meets the degree of protection when the root cable is correctly connected with the F3SG-SR. The degree of protection is not satisfied with the part where cable wires are uncovered.			
		Number of wires	Emitter: 5, Receiver: 8			
		Cable length	 See 5-4-3-1. <i>Root-Straight Cable</i> and 5-4-3-2. <i>Root-Plug Cable for Extended</i> for more information.			
		Cable diameter	6 mm			
		Minimum bending radius	R5 mm			
	Cascading cable	Type of connection	To sensors: dedicated connector, To cascading sensors: M12 connector type (5-pin emitter and 8-pin receiver) or dedicated connector IP67 and IP67G (JIS C 0920 Annex 1) * rated when mated. * The F3SG-SR meets the degree of protection when the cascading cable is correctly connected with the F3SG-SR and the root cable.			
		Number of wires	Emitter: 5, Receiver: 8			
		Cable length	 See 5-4-3-5. <i>Cascading Cable for Extended</i> for more information.			
		Cable diameter	6 mm			
		Minimum bending radius	R5 mm			
	Extension cable - Extended Socket-Straight Cable - Extended Plug-Socket Cable	Type of connection	M12 connector type (5-pin emitter and 8-pin receiver), IP67* rated when mated The extension cable meets the degree of protection when the root cable is correctly connected with the extension cable. The degree of protection is not satisfied with the part where cable wires are uncovered.			
		Number of wires	Emitter: 5, Receiver: 8			
		Cable length	 See 5-4-3-3. <i>Extended Socket-Straight Cable</i> and 5-4-3-4. <i>Extended Plug-Socket Cable</i> for more information.			
		Cable diameter	6.6 mm			
		Minimum bending radius	R36 mm			





Model		F3SG-□SRA□□□□-14 F3SG-□SRB□□□□-14	F3SG-□SRA□□□□-25 F3SG-□SRB□□□□-25	F3SG-□SRA□□□□-45 F3SG-□SRB□□□□-45	F3SG-□SRA□□□□-85 F3SG-□SRB□□□□-85
Connections	Cable extension	 See the section following this table for the restrictions on cable extension.			
		Root cable	In optical synchronization: 100 m max* between power supply and emitter and between power supply and receiver In wired synchronization: 100 m max* between power supply and emitter, between power supply and receiver, and between emitter and receiver * When the Intelligent Tap (F39-SGIT-IL3) is connected to the sensor, this applies in the case of the rated power supply of 24 VDC to 24 VDC +20%.		
		Cascade connection	Extension cable between sensors: 10 m max. (not including Cascading Cable for Extended*1 and Root Cable*2.) *1. F39-JGR3W *2. F39-JGR3K		
Material		Housing: Aluminum alloy Cap: PBT resin Front window: Acrylic resin FE plate: Stainless steel			
Weight		 See 1-6-2. List of Models, Current Consumption and Weight for more information.			
Included accessories		Instruction Sheet, Quick Installation Manual, Troubleshooting Guide Sticker, Warning Zone Label, End Cap (for switching Scan Code Selection function)			
Conformity	Conforming standards		 See Legislation and Standards for more information.		
	Type of ESPE (IEC 61496-1)		F3SG-4SR□□□□□□-□□: Type 4 F3SG-2SR□□□□□□-□□: Type 2		
	Performance Level (PL)/Safety category		F3SG-4SR□□□□□□-□□: PL e/Category 4 (EN ISO 13849-1:2015) F3SG-2SR□□□□□□-□□: PL c/Category 2 (EN ISO 13849-1:2015)		
	PFH _b		F3SG-□SR□□□□□□-□□: 1.1×10 ⁻⁸ max. (IEC 61508)		
	Proof test interval T _M		Every 20 years (IEC 61508)		
	SFF		99% (IEC 61508)		
	HFT		1 (IEC 61508)		
	Classification		Type B (IEC 61508-2)		

1-5-2. F3SG-PG Series

Model		F3SG-4PGA□□□□-□A	F3SG-4PGA□□□□-□L	F3SG-4PGA□□□□-□C	
Performance	Detection capability *		Opaque objects, 30-mm dia. *It is the minimum diameter of an object that can be detected on the any optical axes, and the definition of the term is different from that for the F3SG-SR. The minimum diameter that can be detected in any position of the product length is "detection capability (30 mm) + beam gap".		
	Beam gap		F3SG-4PGA0670-2□: 500 mm F3SG-4PGA0970-3□: 400 mm F3SG-4PGA1070-4□: 300 mm F3SG-4PGA1370-4□: 400 mm	F3SG-4PGA0670-2□: 500mm F3SG-4PGA1070-4□: 300mm F3SG-4PGA1370-4□: 400mm	
	Number of beams		F3SG-4PGA0670-2□: 2 F3SG-4PGA0970-3□: 3 F3SG-4PGA1070-4□: 4 F3SG-4PGA1370-4□: 4	F3SG-4PGA0670-2□: 2 F3SG-4PGA1070-4□: 4 F3SG-4PGA1370-4□: 4	
	Lens size		8.1 x 12.8 mm (W x H)		
	Product length		670, 970, 1,070, 1,370 mm		
	Operating range	Long	0.5 to 20 m	20 to 70 m	0.5 to 5 m
		Short		0.5 to 20 m	
	Response time	Normal mode	ON to OFF	Optical synchronization: 8 ms Wired synchronization: 10 ms	
			OFF to ON	Optical synchronization: 40 ms Wired synchronization: 50 ms	
		×2 Slow mode *	ON to OFF	Optical synchronization: 16 ms Wired synchronization: 20 ms	
			OFF to ON	Optical synchronization: 80 ms Wired synchronization: 100 ms	
		×4 Slow mode *	ON to OFF	Optical synchronization: 32 ms Wired synchronization: 40 ms	
			OFF to ON	Optical synchronization: 160 ms Wired synchronization: 200 ms	
×8 Slow mode *		ON to OFF	Optical synchronization: 64 ms Wired synchronization: 80 ms		
		OFF to ON	Optical synchronization: 320 ms Wired synchronization: 400 ms		
* Selectable by SD Manager 3					
Effective aperture angle (EAA) (IEC 61496-2)		±2.5° or less at operating range of 3 m or greater for emitter, receiver, and emitter/receiver Not applicable to passive mirror			
Light source		Infrared LEDs, Wavelength: 870 nm			
Startup waiting time		3 s max.			



Model		F3SG-4PGA□□□□-□A	F3SG-4PGA□□□□-□L	F3SG-4PGA□□□□-□C	
Electrical	Power supply voltage (Vs)	SELV/PELV 24 VDC±20% (ripple p-p 10% max.)			
	Current consumption	See 1-6. <i>List of Models</i> for more information.			
	Safety outputs (OSSD)	<p>Two PNP or NPN transistor outputs (PNP or NPN is selectable by wiring of power supply.) Load current: 300 mA max., Residual voltage: 2 V max. (except for voltage drop due to cable extension), Capacitive load: 1 µF max., Inductive load: 2.2 H max. *1 *2 *3 Leakage current: 1 mA max.(PNP), 2 mA max.(NPN) *4</p> <p>*1. The load current is 150 mA max. when the operating ambient temperature is 45 to 55°C. *2. The residual voltage is 3 V max. when the Intelligent Tap is connected to the sensor. *3. The load inductance is the maximum value when the safety output frequently repeats ON and OFF. When you use the safety output at 4 Hz or less, the usable load inductance becomes larger. *4. These values must be taken into consideration when connecting elements including a capacitive load such as a capacitor.</p>			
	Auxiliary output	<p>One PNP or NPN transistor output (PNP or NPN is selectable by wiring of power supply.) Load current: 100 mA max., Residual voltage: 2 V max. * * The residual voltage is 3 V max. when the Intelligent Tap is connected to the sensor.</p>			
	Output operation mode	Safety output	Light-ON (Safety outputs are turned to the ON state when the receiver receives an emitting signal.)		
		Auxiliary output	Safety output (Inverted signal output: Enable) (default) (Configurable by SD Manager 3)		
	Input voltage	TEST	<p>Light emission stops when connected to 24 VDC ON voltage: Vs-3 V to Vs (short circuit current: approx. 5.0 mA) * OFF voltage: 0 V to 1/2 Vs, or open (short circuit current: approx. 6.0 mA) *</p> <p>Light emission stops when connected to 0 V ON voltage: 0 to 3 V (short circuit current: approx. 6.0 mA) OFF voltage: 1/2 Vs to Vs, or open (short circuit current: approx. 5.0 mA) *</p>		-
		OPERATING RANGE SELECT INPUT	-	<p>Long: 12 V to Vs (short circuit current: approx. 4.2 mA) * or open Short: 0 to 3 V (short circuit current: approx. 4.2 mA)</p>	-
		RESET/EDM	<p>PNP ON voltage: Vs-3 V to Vs (short circuit current: approx. 9.5 mA) * OFF voltage: 0 V to 1/2 Vs, or open (short circuit current: approx. 13.0 mA) * NPN ON voltage: 0 to 3 V (short circuit current: approx. 13.0 mA) OFF voltage: 1/2 Vs to Vs, or open (short circuit current: approx. 9.5 mA) *</p>		
		MUTE A/B, PRE-RESET	<p>PNP ON voltage: Vs-3 V to Vs (short circuit current: approx. 4.5 mA) * OFF voltage: 0 V to 1/2 Vs, or open (short circuit current: approx. 7.0 mA) * NPN ON voltage: 0 to 3 V (short circuit current: approx. 7.0 mA) OFF voltage: 1/2 Vs to Vs, or open (short circuit current: approx. 4.5 mA) *</p>		
			*The Vs indicates a supply voltage value in your environment.		
	Overvoltage category (IEC 60664-1)	II			
	Indicators	See 1-4. <i>LED Indicators on F3SG-SR/PG</i> for more information.			
Protective circuit	Output short-circuit protection				
Insulation resistance	20 MΩ or higher (500 VDC megger)				
Dielectric strength	1,000 VAC, 50/60 Hz (1 min)				



Model		F3SG-4PGA□□□□-□A	F3SG-4PGA□□□□-□L	F3SG-4PGA□□□□-□C
Functional	Mutual interference prevention	Optical synchronization by Scan Code: in up to 2 sets Wired synchronization: in up to 3 sets  See 5-1-4. <i>Mutual Interference Prevention</i> for more information.		
	Cascade connection	-		
	Test function	Self-test (at power-on, and during operation) External test (light emission stop function by test input)	Self-test (at power-on, and during operation)	
	Safety-related functions	Interlock External Device Monitoring (EDM) Pre-Reset Muting/Override Mutual Interference Prevention PNP/NPN Selection Response Time Adjustment  See <i>Chapter 2 System Operation and Functions</i> and <i>Chapter 3 Setting with Intelligent Tap</i> for more information.		
Environmental	Ambient temperature	Operating	-30 to 55 °C (non-icing)	
		Storage	-30 to 70 °C	
	Ambient humidity	Operating	35% to 85% (non-condensing)	
		Storage	35% to 95%	
	Ambient illuminance	Incandescent lamp: 3,000 lx max. on receiver surface Sunlight: 10,000 lx max. on receiver surface		
	Degree of protection (IEC 60529)	IEC 60529: IP65 and IP67		
	Vibration resistance (IEC 61496-1)	Class 3M4 (IEC TR 60721-4-3) Operation limit: 5~150Hz, Multiple amplitude of 7 mm, Acceleration of 1G, 10 sweeps each in X, Y, and Z directions (no delay at resonant frequencies)		
	Shock resistance (IEC 61496-1)	Class 3M4 (IEC TR 60721-4-3) Operation limit: Acceleration of 15G, Pulse duration of 6ms, 100 shocks for each in X, Y, and Z directions (600 shocks in total)		
Pollution degree (IEC 60664-1)	3			
Connections	Root cable	Type of connection	To sensors: dedicated connector, To external: M12 connector type (5-pin emitter and 8-pin receiver) or open-ended type IP67 (JIS C 0920 Annex 1) * rated when mated. * The F3SG-PG meets the degree of protection when the root cable is correctly connected with the F3SG-PG. The degree of protection is not satisfied with the part where cable wires are uncovered.	
		Number of wires	Emitter: 5, Receiver: 8, Emitter/Receiver: 8	
		Cable length	 See 5-4-3-1. <i>Root-Straight Cable</i> and 5-4-3-2. <i>Root-Plug Cable for Extended</i> for more information.	
		Cable diameter	6 mm	
		Minimum bending radius	R5 mm	

Model		F3SG-4PGA□□□□-□A	F3SG-4PGA□□□□-□L	F3SG-4PGA□□□□-□C
Connections	Extension cable - Extended Socket-Straight Cable - Extended Plug-Socket Cable	Type of connection	M12 connector type (5-pin emitter and 8-pin emitter/receiver), IP67* rated when mated The extension cable meets the degree of protection when the root cable is correctly connected with the extension cable. The degree of protection is not satisfied with the part where cable wires are uncovered.	
		Number of wires	Emitter: 5, Receiver: 8, Emitter/Receiver: 8	
		Cable length	 See the section following this table for the restrictions on cable extension.	
		Cable diameter	6.6 mm	
		Minimum bending radius	R36 mm	
Connections	Cable extension	 See the section following this table for the restrictions on cable extension.		
		Root cable	In optical synchronization: 100 m max* between power supply and emitter and between power supply and receiver In wired synchronization: 100 m max* between power supply and emitter, between power supply and receiver, and between emitter and receiver * When the Intelligent Tap (F39-SGIT-IL3) is connected to the sensor, this applies in the case of the rated power supply of 24 VDC to 24 VDC +20%.	
Material		Housing: Aluminum alloy Cap: PBT resin Front window: Acrylic resin FE plate: Stainless steel		
Weight		 See 1-6-2. List of Models, Current Consumption and Weight for more information.		
Included accessories		Instruction Sheet, Quick Installation Manual, Troubleshooting Guide Sticker, End Cap (for switching Scan Code Selection function)		
Conformity	Conforming standards		 See <i>Legislation and Standards</i> for more information.	
	Type of ESPE (IEC 61496-1)		Type 4	
	Performance Level (PL)/Safety category		PL e/Category 4 (EN ISO 13849-1:2015)	
	PFH _D		1.1×10 ⁻⁸ max. (IEC 61508)	
	Proof test interval T _M		Every 20 years (IEC 61508)	
	SFF		99% (IEC 61508)	
	HFT		1 (IEC 61508)	
	Classification		Type B (IEC 61508-2)	

1-5-3. F3SG-SR IP69K Model

Model		F3SG-4SRB□□□□-14-K	F3SG-4SRB□□□□-25-K		
Performance	Detection capability		Opaque objects		
	Beam gap		10 mm	20 mm	
	Number of beams		31 to 179	16 to 92	
	Lens size		4.4 × 3.4 mm (W × H)	6.7 × 4.5 mm (W × H)	
	Protective height		320 to 1,800 mm	320 to 1,840 mm	
	Operating range	Long	0.3 to 8.0 m	0.3 to 16.0 m	
		Short	0.3 to 2.4 m	0.3 to 5.6 m	
	* When operating at an ambient temperature of -10 to -30°C, use the F3SG-SR with the operating range of 0.3 to 4.0 m in Long Mode and 0.3 to 1.2 m in Short Mode.				
	Response time	Normal mode	ON to OFF	Optical synchronization: 8 to 18 ms Wired synchronization: 10 to 21 ms	Optical synchronization: 8 to 13 ms Wired synchronization: 10 to 17 ms
			OFF to ON	Optical synchronization: 40 to 90 ms Wired synchronization: 50 to 105 ms	Optical synchronization: 40 to 65 ms Wired synchronization: 50 to 85 ms
		×2 Slow mode *	ON to OFF	Optical synchronization: 16 to 36 ms Wired synchronization: 20 to 42 ms	Optical synchronization: 16 to 26 ms Wired synchronization: 20 to 34 ms
			OFF to ON	Optical synchronization: 80 to 180 ms Wired synchronization: 100 to 210 ms	Optical synchronization: 80 to 130 ms Wired synchronization: 100 to 170 ms
		×4 Slow mode *	ON to OFF	Optical synchronization: 32 to 72 ms Wired synchronization: 40 to 84 ms	Optical synchronization: 32 to 52 ms Wired synchronization: 40 to 68 ms
			OFF to ON	Optical synchronization: 160 to 360 ms Wired synchronization: 200 to 420 ms	Optical synchronization: 160 to 260 ms Wired synchronization: 200 to 340 ms
×8 Slow mode *		ON to OFF	Optical synchronization: 64 to 144 ms Wired synchronization: 80 to 168 ms	Optical synchronization: 64 to 104 ms Wired synchronization: 80 to 136 ms	
		OFF to ON	Optical synchronization: 320 to 720 ms Wired synchronization: 400 to 840 ms	Optical synchronization: 320 to 520 ms Wired synchronization: 400 to 680 ms	
* Selectable by SD Manager 3.					
Effective aperture angle (EAA) (IEC 61496-2)		±2.5° or less at operating range of 3 m or greater for emitter and receiver			
Light source		Infrared LEDs, Wavelength: 870 nm			
Startup waiting time		3 s max.			
Electrical	Power supply voltage (Vs)		SELV/PELV 24 VDC±20% (ripple p-p 10% max.)		
	Current consumption		 See 1-6. List of Models for more information.		
	Safety outputs (OSSD)		Two PNP or NPN transistor outputs (PNP or NPN is selectable by wiring of power supply.) Load current: 300 mA max., Residual voltage: 2 V max. (except for voltage drop due to cable extension), Capacitive load: 1 µF max., Inductive load: 2.2 H max. *1 *2 Leakage current: 1 mA max.(PNP), 2 mA max.(NPN) *3 *1. The residual voltage is 3 V max. when the Intelligent Tap is connected to the sensor. *2. The load inductance is the maximum value when the safety output frequently repeats ON and OFF. When you use the safety output at 4 Hz or less, the usable load inductance becomes larger. *3. These values must be taken into consideration when connecting elements including a capacitive load such as a capacitor.		
	Auxiliary output		One PNP or NPN transistor output (PNP or NPN is selectable by wiring of power supply.) Load current: 100 mA max., Residual voltage: 2 V max. * * The residual voltage is 3 V max. when the Intelligent Tap is connected to the sensor.		
	Output operation mode	Safety output	Light-ON (Safety outputs are turned to the ON state when the receiver receives an emitting signal.)		
Auxiliary output		Safety output (Inverted signal output: Enable) (default) (Configurable by SD Manager 3)			

Model			F3SG-4SRB□□□□-14-K	F3SG-4SRB□□□□-25-K	
Electrical	Input voltage	TEST	Light emission stops when connected to 24 VDC ON voltage: Vs-3 V to Vs (short circuit current: approx. 5.0 mA) * OFF voltage: 0 V to 1/2 Vs, or open (short circuit current: approx. 6.0 mA) * Light emission stops when connected to 0 V ON voltage: 0 to 3 V (short circuit current: approx. 6.0 mA) OFF voltage: 1/2 Vs to Vs, or open (short circuit current: approx. 5.0 mA) *		
		OPERATING RANGE SELECT INPUT	Long: 12 V to Vs (short circuit current: approx. 4.2 mA) * or open Short: 0 to 3 V (short circuit current: approx. 4.2 mA)		
		RESET/EDM	PNP ON voltage: Vs-3 V to Vs (short circuit current: approx. 9.5 mA) * OFF voltage: 0 V to 1/2 Vs, or open (short circuit current: approx. 13.0 mA) * NPN ON voltage: 0 to 3 V (short circuit current: approx. 13.0 mA) OFF voltage: 1/2 Vs to Vs, or open (short circuit current: approx. 9.5 mA) *		
		MUTE A/B, PRE-RESET, PSDI	PNP ON voltage: Vs-3 V to Vs (short circuit current: approx. 4.5 mA) * OFF voltage: 0 V to 1/2 Vs, or open (short circuit current: approx. 7.0 mA) * NPN ON voltage: 0 to 3 V (short circuit current: approx. 7.0 mA) OFF voltage: 1/2 Vs to Vs, or open (short circuit current: approx. 4.5 mA) *		
		*The Vs indicates a supply voltage value in your environment.			
	Overvoltage category (IEC 60664-1)		II		
	Indicators		 See 1-4. LED Indicators on F3SG-SR/PG for more information.		
	Protective circuit		Output short-circuit protection		
	Insulation resistance		20 MΩ or higher (500 VDC megger)		
	Dielectric strength		1,000 VAC, 50/60 Hz (1 min)		
Functional	Mutual interference prevention	Optical synchronization: fixed to Scan Code A Wired synchronization: in up to 3 sets  See 5-1-4. Mutual Interference Prevention for more information.			
	Cascade connection	-			
	Test function	Self-test (at power-on, and during operation) External test (light emission stop function by test input)			
	Safety-related functions	Interlock External Device Monitoring (EDM) Pre-Reset PSDI Fixed Blanking/Floating Blanking Reduced Resolution Muting/Override Mutual Interference Prevention PNP/NPN Selection Response Time Adjustment  See Chapter 2 System Operation and Functions and Chapter 3 Setting with Intelligent Tap for more information.			

Model		F3SG-4SRB□□□□-14-K	F3SG-4SRB□□□□-25-K	
Environmental	Ambient temperature	Operating	-30 to 55 °C (non-icing)	
		Storage	-30 to 70 °C	
	Ambient humidity	Operating	35% to 85% (non-condensing)	
		Storage	35% to 95%	
	Ambient illuminance		Incandescent lamp: 3,000 lx max. on receiver surface Sunlight: 10,000 lx max. on receiver surface	
	Degree of protection (IEC 60529)		IEC 60529: IP65 and IP67, ISO 20653: IP69K	
	Vibration resistance (IEC 61496-1)		Class 3M4 (IEC TR 60721-4-3) Operation limit: 5~150Hz, Multiple amplitude of 7 mm, Acceleration of 1G, 10 sweeps each in X, Y, and Z directions (no delay at resonant frequencies)	
	Shock resistance (IEC 61496-1)		Class 3M4 (IEC TR 60721-4-3) Operation limit: Acceleration of 15G, Pulse duration of 6ms, 100 shocks for each in X, Y, and Z directions (600 shocks in total)	
Pollution degree (IEC 60664-1)		3		
Connections	Root cable	Type of connection	Open-ended type	
		Number of wires	Emitter: 5, Receiver: 8	
		Cable length	15 m	
		Cable diameter	6 mm	
		Minimum bending radius	R5 mm	
	Cable extension	 See the section following this table for the restrictions on cable extension.		
		Root cable	In optical synchronization: 100 m max* between power supply and emitter and between power supply and receiver In wired synchronization: 100 m max* between power supply and emitter, between power supply and receiver, and between emitter and receiver * When the Intelligent Tap (F39-SGIT-IL3) is connected to the sensor, this applies in the case of the rated power supply of 24 VDC to 24 VDC +20%.	
Material		Pipe: acrylic resin Cap: SUS316L		
Weight		 See 1-6-2. <i>List of Models, Current Consumption and Weight</i> for more information.		
Included accessories		Instruction Sheet, Quick Installation Manual, Troubleshooting Guide Sticker		
Conformity	Conforming standards		 See <i>Legislation and Standards</i> for more information.	
	Type of ESPE (IEC 61496-1)		Type 4	
	Performance Level (PL)/Safety category		PL e/Category 4 (EN ISO 13849-1:2015)	
	PFH _b		1.1×10 ⁻⁸ max. (IEC 61508)	
	Proof test interval T _M		Every 20 years (IEC 61508)	
	SFF		99% (IEC 61508)	
	HFT		1 (IEC 61508)	
	Classification		Type B (IEC 61508-2)	

■ Restrictions on cable extension

The cable extension must satisfy all the following conditions.

<Intelligent Tap not used>

- Wired synchronization

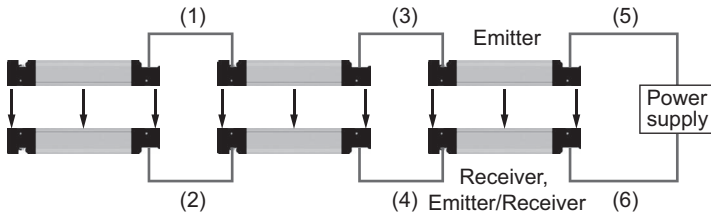

Maximum extension length
(1) to (4): 10 m each *
(5) to (6): 100 m

- Optical synchronization

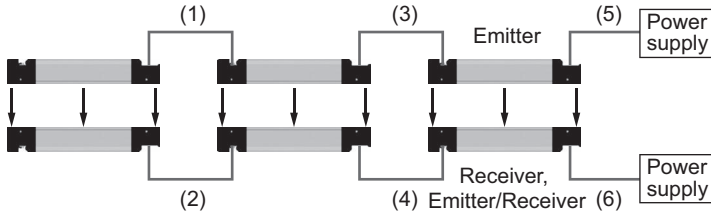

Maximum extension length
(1) to (4): 10 m each *
(5) to (6): 100 m each

* Not including Cascading Cable for Extended (F39-JGR3W) and Root Cable (F39-JGR3K).
In addition, cascade connection function is not supported by F3SG-PG and F3SG-SR-K series.

<Intelligent Tap used>

- Wired synchronization

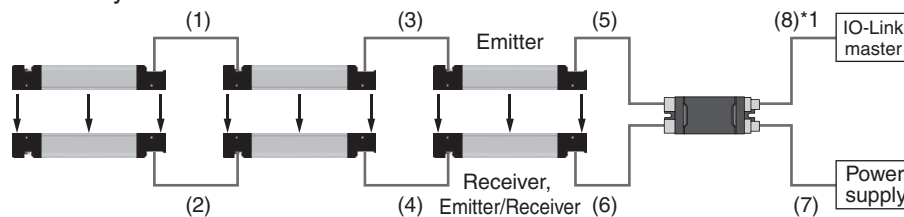

Maximum cable extension (Load condition: Safety outputs 1 and 2: 60 mA, Auxiliary output: 60 mA)

Sensor	F3SG-□SR *2			F3SG-□PG *2	F3SG-□SR-K *2
	Single	2-segment *3	3-segment *3		
Cascading	Single	2-segment *3	3-segment *3	Single	Single
(1),(2),(3),(4)	10 m each *4			None	None
(5),(6)	50 m each			50 m each	50 m each
(5)+(7)	100 m	70 m	60 m	100 m	100 m
(6)+(7)					

*1. (8) must be 20 m max.

*2. Under the maximum load conditions (safety outputs 1 and 2 of 300 mA per channel and auxiliary output of 100 mA), the cable extension must be 50% max. of the length listed in the table.

*3. Conditions exist for the use of the F3SG-4SRA in 2-segment or 3-segment cascade. Refer to 1-5-1. F3SG-SR Series – Electrical – Safety outputs (OSSD).

*4. Not including the Cascading Cable for Extended (F39-JGR3W) and the Root-Plug Cable for Extended (F39-JGR3K).

- Optical synchronization

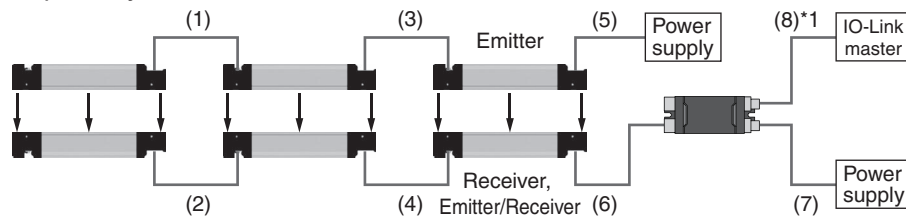

Maximum cable extension (Load condition: Safety outputs 1 and 2: 60 mA, Auxiliary output : 60 mA)

Sensor	F3SG-□SR *2			F3SG-□PG *2	F3SG-□SR-K *2	
	Cascading	Single	2-segment *3			3-segment *3
(1),(2),(3),(4)		10 m each *4			None	None
(5)		100 m			100 m	100 m
(6)		50 m			50 m	50 m
(6)+(7)	100 m	100 m	80 m	100 m	100m	

*1. (8) must be 20 m max.

*2. Under the maximum load conditions (safety outputs 1 and 2 of 300 mA per channel and auxiliary output of 100 mA), the cable extension must be 50% max. of the length listed in the table.

*3. Conditions exist for the use of the F3SG-4SRA in 2-segment or 3-segment cascade. Refer to 1-5-1. F3SG-SR Series – Electrical – Safety outputs (OSSD).

*4. Not including the Cascading Cable for Extended (F39-JGR3W) and the Root-Plug Cable for Extended (F39-JGR3K).

<Using Y-Joint Plug/Socket Connector (F39-GCNY2)>

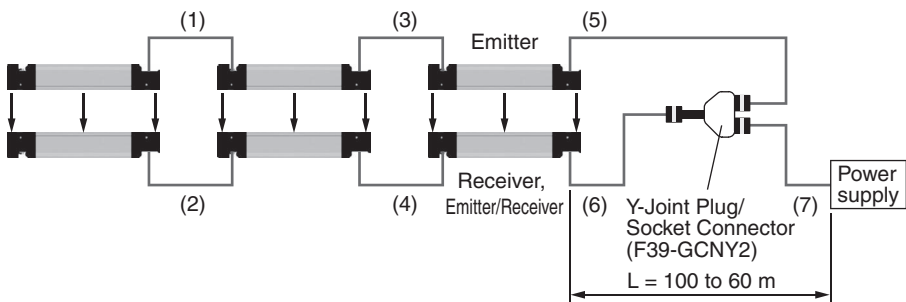

Maximum cable extension (Load condition: Safety outputs 1 and 2: 60 mA, Auxiliary output : 60 mA)



Sensor	F3SG-□SR *1			F3SG-□PG *1	F3SG-□SR-K *1	
	Cascading	Single	2-segment *2			3-segment *2
(1),(2),(3),(4)		10 m each *3			None	None
L: (5)+(7) (6)+(7)	100 m	70 m	60 m	100 m	100 m	

*1. Under the maximum load conditions (safety outputs 1 and 2 of 300 mA per channel and auxiliary output of 100 mA), the cable extension must be 50% max. of the length listed in the table.

*2. Conditions exist for the use of the F3SG-4SRA in 2-segment or 3-segment cascade. Refer to 1-5-1. F3SG-SR Series – Electrical – Safety outputs (OSSD).

*3. Not including the Cascading Cable for Extended (F39-JGR3W) and the Root-Plug Cable for Extended (F39-JGR3K).

1-5-4. Intelligent Tap

Model		F39-SGIT-IL3		
Applicable sensor		F3SG-SR/PG Series		
Performance	Response time	Output ON to OFF and OFF to ON: 44 ms max. each * *The response time is the time interval between the changes of the states of the sensor OSSD's and the DO (pin 2).		
	Startup waiting time	3 s max.		
Electrical	Power supply voltage (Vs)	Supplied from external power source: SELV/PELV 24 VDC±20% (ripple p-p 10% max.) USB bus powered: 5 VDC		
	Current consumption	85 mA max. (When connecting 24 VDC power supply and IO-Link Master)		
	Safety outputs (OSSD)/ Auxiliary output	Refer to the ratings and specifications of the F3SG-SR/PG. The safety outputs and auxiliary output of the Intelligent Tap are directly connected to those of the F3SG-SR/PG.  See 1-5-1. F3SG-SR Series for more information.		
	Digital output for pin 2 (IO-Link) *	One PNP transistor output Load current: 100 mA max., Residual voltage: 2 V max., Leakage current: 1 mA max. The DO is in the OFF state when the safety outputs are in the ON state. The DO is in the ON state when the safety outputs are in the OFF state. (Regardless of the PNP/NPN setting of the F3SG-SR)		
	*For the DO (pin 2) of CN3			
	Input voltage	RESET, EDM	PNP ON voltage: Vs-3 V to Vs (short circuit current: approx. 9.5 mA) *2 OFF voltage: 0 V to 1/2 Vs, or open (short circuit current: approx. 13.0 mA) *2 NPN ON voltage: 0 to 3 V (short circuit current: approx. 13.0 mA) OFF voltage: 1/2 Vs to Vs, or open (short circuit current: approx. 9.5 mA) *2	
		MUTE A/B, PRE-RESET, PSDI *1	PNP ON voltage: Vs-3 V to Vs (short circuit current: approx. 4.5 mA) *2 OFF voltage: 0 V to 1/2 Vs, or open (short circuit current: approx. 7.0 mA) *2 NPN ON voltage: 0 to 3 V (short circuit current: approx. 7.0 mA) OFF voltage: 1/2 Vs to Vs, or open (short circuit current: approx. 4.5 mA) *2	
	*1. PSDI is only available for F3SG-SR. *2. The Vs indicates a supply voltage value in your environment.			
	Overvoltage category (IEC 60664-1)	II		
	Protective circuit	Output short-circuit protection, Output reverse polarity protection		
Insulation resistance	20 MΩ or higher (500 VDC megger)			
Dielectric strength	1,000 VAC, 50/60 Hz (1 min)			
Functional	Maintenance Information	Error Log Power-ON Time  See 2-27. Maintenance Information for more information.		
Environmental	Ambient temperature	Operating	-30 to 55 °C (non-icing)	
		Storage	-30 to 70 °C	
	Ambient humidity	Operating	35% to 85% (non-condensing)	
		Storage	35% to 85%	
	Degree of protection (IEC 60529)	IP65 and IP67 (Covers and cables connected.)		
	Vibration resistance (IEC 61496-1)	10 to 55 Hz, Multiple amplitude of 0.7 mm, 20 sweeps for all 3 axes		
	Shock resistance (IEC 61496-1)	100 m/s ² , 1000 shocks for all 3 axes		
	Pollution degree (IEC 60664-1)	3		

Model		F39-SGIT-IL3
Connections	To sensors, control box and IO-Link	M12 connectors: 8-pin (CN1: receiver and CN2: control box) and 5-pin (CN3: IO-Link and CN4: emitter), IP67 (JIS C 0920 Annex 1) rated when mated.
	Connection	USB Type-C™
	Cable extension	20 m max. between IO-Link Master and Intelligent Tap, 4 m max.* between PC and Intelligent Tap via USB cable * It is not guaranteed that the Intelligent Tap is connectable to any PC or USB cable. Verify the connection with the USB cable you use.
IO-Link communications	IO-Link version	Version 1.1
	Baud rate	COM3: 230.4 kbps
	Data length	PD: 4 bytes, OD: 32 bytes (M-sequence type: TYPE_2_V)
	Minimum cycle time	22 ms
Material		PBT resin
Weight		F39-SGIT-IL3: 180 g (when packaged), F39-LITF1: 50 g (when packaged)
Included accessories		Instruction Sheet and M12 Connector Cover (2 pcs)

1-5-5. Bluetooth® Communication Unit

Model	F39-SGBT
Applicable sensor	F3SG-SR Series
Power supply voltage (Vs)	24 VDC±20%, ripple p-p 10% max. (shares power supply of Intelligent Tap)
Current consumption	30 mA max. (shares power supply of Intelligent Tap)
Ambient temperature	Operating: -30 to 55 °C (non-icing) Storage: -30 to 70 °C
Ambient humidity	Operating: 35% to 85% (non-condensing) Storage: 35% to 85%
Degree of protection	IP65 and IP67 (rated when connected to Intelligent Tap)
Vibration resistance	10 to 55 Hz, Multiple amplitude of 0.7 mm, 20 sweeps for all 3 axes
Shock resistance	100m/s ² , 1000 shocks for all 3 axes
Type of connection	To be connected to Intelligent Tap
Communication system	Bluetooth® Version 3.0
Communication profile	SPP (Serial Port Profile)
Transmission distance	Approx. 10 m max. (Output power: Class 2) *
Material	PBT resin
Weight	70g (when packaged)

*It depends on use environment conditions.

1-6. List of Models

1-6-1. List of Models and Response Times

1-6-1-1. F3SG-SR

- Finger protection (Detection capability: 14-mm dia.)

Model		Number of beams	Protective height [mm]	Response time (Optical synchronization) [ms]			Response time (Wired synchronization) [ms]	
				ON to OFF	OFF (synchronized) to ON	OFF (not synchronized) to ON	ON to OFF	OFF to ON
F3SG-4SR□0160-14	F3SG-2SRB0160-14	15	160	8	40	140	10	50
F3SG-4SR□0200-14-F	---	19	200	8	40	140	10	50
F3SG-4SR□0240-14	F3SG-2SRB0240-14	23	240	8	40	140	10	50
F3SG-4SR□0280-14-F	---	27	280	8	40	140	10	50
F3SG-4SR□0320-14	F3SG-2SRB0320-14	31	320	8	40	140	10	50
F3SG-4SR□0360-14-F	---	35	360	8	40	140	10	50
F3SG-4SR□0400-14	F3SG-2SRB0400-14	39	400	8	40	140	10	50
F3SG-4SR□0440-14-F	---	43	440	13	65	165	17	85
F3SG-4SR□0480-14	F3SG-2SRB0480-14	47	480	13	65	165	17	85
F3SG-4SR□0520-14-F	---	51	520	13	65	165	17	85
F3SG-4SR□0560-14	F3SG-2SRB0560-14	55	560	13	65	165	17	85
F3SG-4SR□0600-14-F	---	59	600	13	65	165	17	85
F3SG-4SR□0640-14	F3SG-2SRB0640-14	63	640	13	65	165	17	85
F3SG-4SR□0680-14-F	---	67	680	13	65	165	17	85
F3SG-4SR□0720-14-F	---	71	720	13	65	165	17	85
F3SG-4SR□0760-14-F	---	75	760	13	65	165	17	85
F3SG-4SR□0800-14	F3SG-2SRB0800-14	79	800	13	65	165	17	85
F3SG-4SR□0840-14-F	---	83	840	13	65	165	17	85
F3SG-4SR□0880-14-F	---	87	880	13	65	165	17	85
F3SG-4SR□0920-14-F	---	91	920	13	65	165	17	85
F3SG-4SR□0960-14-F	---	95	960	13	65	165	17	85
F3SG-4SR□1000-14	F3SG-2SRB1000-14	99	1000	13	65	165	17	85
F3SG-4SR□1200-14	F3SG-2SRB1200-14	119	1200	13	65	165	17	85
F3SG-4SR□1400-14	F3SG-2SRB1400-14	139	1400	13	65	165	17	85
F3SG-4SR□1600-14	F3SG-2SRB1600-14	159	1600	18	90	190	21	105
F3SG-4SR□1800-14	F3SG-2SRB1800-14	179	1800	18	90	190	21	105
F3SG-4SR□2000-14	F3SG-2SRB2000-14	199	2000	18	90	190	21	105

Note 1. The maximum speed of movement of a test rod up to which the detection capability is maintained is 2.0 m/s.

Note 2. The response times are values when Scan Code is set at Code B. The response times for Code A are 1 ms shorter than these values.

 Refer to 2-3. *Mutual Interference Prevention* for more information.

■ Hand protection (Detection capability: 25-mm dia.)

Model		Number of beams	Protective height [mm]	Response time (Optical synchronization) [ms]			Response time (Wired synchronization) [ms]	
				ON to OFF	OFF (synchronized) to ON	OFF (not synchronized) to ON	ON to OFF	OFF to ON
F3SG-4SR□0160-25	F3SG-2SRB0160-25	8	160	8	40	140	10	50
F3SG-4SR□0200-25-F	---	10	200	8	40	140	10	50
F3SG-4SR□0240-25	F3SG-2SRB0240-25	12	240	8	40	140	10	50
F3SG-4SR□0280-25-F	---	14	280	8	40	140	10	50
F3SG-4SR□0320-25	F3SG-2SRB0320-25	16	320	8	40	140	10	50
F3SG-4SR□0360-25-F	---	18	360	8	40	140	10	50
F3SG-4SR□0400-25	F3SG-2SRB0400-25	20	400	8	40	140	10	50
F3SG-4SR□0440-25-F	---	22	440	8	40	140	10	50
F3SG-4SR□0480-25	F3SG-2SRB0480-25	24	480	8	40	140	10	50
F3SG-4SR□0520-25-F	---	26	520	8	40	140	10	50
F3SG-4SR□0560-25	F3SG-2SRB0560-25	28	560	8	40	140	10	50
F3SG-4SR□0600-25-F	---	30	600	8	40	140	10	50
F3SG-4SR□0640-25	F3SG-2SRB0640-25	32	640	8	40	140	10	50
F3SG-4SR□0680-25-F	---	34	680	8	40	140	10	50
F3SG-4SR□0720-25	F3SG-2SRB0720-25	36	720	8	40	140	10	50
F3SG-4SR□0760-25-F	---	38	760	8	40	140	10	50
F3SG-4SR□0800-25	F3SG-2SRB0800-25	40	800	8	40	140	10	50
F3SG-4SR□0840-25-F	---	42	840	13	65	165	17	85
F3SG-4SR□0880-25	F3SG-2SRB0880-25	44	880	13	65	165	17	85
F3SG-4SR□0920-25-F	---	46	920	13	65	165	17	85
F3SG-4SR□0960-25	F3SG-2SRB0960-25	48	960	13	65	165	17	85
F3SG-4SR□1000-25-F	---	50	1000	13	65	165	17	85
F3SG-4SR□1040-25	F3SG-2SRB1040-25	52	1040	13	65	165	17	85
F3SG-4SR□1120-25	F3SG-2SRB1120-25	56	1120	13	65	165	17	85
F3SG-4SR□1200-25	F3SG-2SRB1200-25	60	1200	13	65	165	17	85
F3SG-4SR□1280-25	F3SG-2SRB1280-25	64	1280	13	65	165	17	85
F3SG-4SR□1360-25	F3SG-2SRB1360-25	68	1360	13	65	165	17	85
F3SG-4SR□1440-25	F3SG-2SRB1440-25	72	1440	13	65	165	17	85
F3SG-4SR□1520-25	F3SG-2SRB1520-25	76	1520	13	65	165	17	85
F3SG-4SR□1600-25	F3SG-2SRB1600-25	80	1600	13	65	165	17	85
F3SG-4SR□1680-25	F3SG-2SRB1680-25	84	1680	13	65	165	17	85
F3SG-4SR□1760-25	F3SG-2SRB1760-25	88	1760	13	65	165	17	85
F3SG-4SR□1840-25	F3SG-2SRB1840-25	92	1840	13	65	165	17	85
F3SG-4SR□1920-25	F3SG-2SRB1920-25	96	1920	13	65	165	17	85
F3SG-4SR□2080-25	F3SG-2SRB2080-25	104	2080	13	65	165	17	85
F3SG-4SR□2280-25	F3SG-2SRB2280-25	114	2280	13	65	165	17	85
F3SG-4SR□2480-25	F3SG-2SRB2480-25	124	2480	13	65	165	17	85

Note 1. The maximum speed of movement of a test rod up to which the detection capability is maintained is 2.0 m/s.

Note 2. The response times are values when Scan Code is set at Code B. The response times for Code A are 1 ms shorter than these values.

 Refer to 2-3. *Mutual Interference Prevention* for more information.

■ Arm/leg protection (Detection capability: 45-mm dia.)

Model		Number of beams	Protective height [mm]	Response time (Optical synchronization) [ms]			Response time (Wired synchronization) [ms]	
				ON to OFF	OFF (synchronized) to ON	OFF (not synchronized) to ON	ON to OFF	OFF to ON
F3SG-4SR□0240-45	F3SG-2SRB0240-45	6	240	8	40	140	10	50
F3SG-4SR□0400-45	F3SG-2SRB0400-45	10	400	8	40	140	10	50
F3SG-4SR□0560-45	F3SG-2SRB0560-45	14	560	8	40	140	10	50
F3SG-4SR□0720-45	F3SG-2SRB0720-45	18	720	8	40	140	10	50
F3SG-4SR□0880-45	F3SG-2SRB0880-45	22	880	8	40	140	10	50
F3SG-4SR□1200-45	F3SG-2SRB1200-45	30	1200	8	40	140	10	50
F3SG-4SR□1520-45	F3SG-2SRB1520-45	38	1520	8	40	140	10	50

Note 1. The maximum speed of movement of a test rod up to which the detection capability is maintained is 2.0 m/s.

Note 2. The response times are values when Scan Code is set at Code B. The response times for Code A are 1 ms shorter than these values.

 Refer to 2-3. *Mutual Interference Prevention* for more information.

■ Body protection (Detection capability: 85-mm dia.)

Model		Number of beams	Protective height [mm]	Response time (Optical synchronization) [ms]			Response time (Wired synchronization) [ms]	
				ON to OFF	OFF (synchronized) to ON	OFF (not synchronized) to ON	ON to OFF	OFF to ON
F3SG-4SR□0280-85	F3SG-2SRB0280-85	4	280	8	40	140	10	50
F3SG-4SR□0440-85	F3SG-2SRB0440-85	6	440	8	40	140	10	50
F3SG-4SR□0600-85	F3SG-2SRB0600-85	8	600	8	40	140	10	50
F3SG-4SR□0760-85	F3SG-2SRB0760-85	10	760	8	40	140	10	50
F3SG-4SR□0920-85	F3SG-2SRB0920-85	12	920	8	40	140	10	50

Note 1. The maximum speed of movement of a test rod up to which the detection capability is maintained is 2.0 m/s.

Note 2. The response times are values when Scan Code is set at Code B. The response times for Code A are 1 ms shorter than these values.

 Refer to 2-3. *Mutual Interference Prevention* for more information.

1-6-1-2. F3SG-PG Series

■ Standard type for trip function (operating range of 20 m)

Model	Number of beams	Beam gap [mm]	Response time (Optical synchronization) [ms]			Response time (Wired synchronization) [ms]	
			ON to OFF	OFF (synchronized) to ON	OFF (not synchronized) to ON	ON to OFF	OFF to ON
F3SG-4PGA0670-2A	2	500	8	40	140	10	50
F3SG-4PGA0970-3A	3	400	8	40	140	10	50
F3SG-4PGA1070-4A	4	300	8	40	140	10	50
F3SG-4PGA1370-4A	4	400	8	40	140	10	50

Note 1. The maximum speed of movement of a test rod up to which the detection capability is maintained is 2.0 m/s.

Note 2. The response times are values when Scan Code is set at Code B. The response times for Code A are 1 ms shorter than these values.

 Refer to 2-3. *Mutual Interference Prevention* for more information.

■ Long-distance type for trip function (operating range of 70 m)

Model	Number of beams	Beam gap [mm]	Response time (Optical synchronization) [ms]			Response time (Wired synchronization) [ms]	
			ON to OFF	OFF (synchronized) to ON	OFF (not synchronized) to ON	ON to OFF	OFF to ON
F3SG-4PGA0670-2L	2	500	8	40	140	10	50
F3SG-4PGA0970-3L	3	400	8	40	140	10	50
F3SG-4PGA1070-4L	4	300	8	40	140	10	50
F3SG-4PGA1370-4L	4	400	8	40	140	10	50

Note 1. The maximum speed of movement of a test rod up to which the detection capability is maintained is 2.0 m/s.

Note 2. The response times are values when Scan Code is set at Code B. The response times for Code A are 1 ms shorter than these values.

 Refer to 2-3. *Mutual Interference Prevention* for more information.

■ Passive mirror type for trip function (operating range of 5 m)

Model	Number of beams	Beam gap [mm]	Response time (Optical synchronization) [ms]			Response time (Wired synchronization) [ms]	
			ON to OFF	OFF (synchronized) to ON	OFF (not synchronized) to ON	ON to OFF	OFF to ON
F3SG-4PGA0670-2C	2	500	8	40	140	10	50
F3SG-4PGA1070-4C	4	300	8	40	140	10	50
F3SG-4PGA1370-4C	4	400	8	40	140	10	50

Note 1. The maximum speed of movement of a test rod up to which the detection capability is maintained is 2.0 m/s.

Note 2. The response times are values when Scan Code is set at Code B. The response times for Code A are 1 ms shorter than these values.

 Refer to 2-3. *Mutual Interference Prevention* for more information.

1-6-1-3. F3SG-SR IP69K Model

■ For finger detection (Detection capability: 14-mm dia.)

Model	Number of beams	Protective height [mm]	Response time (Optical synchronization) [ms]			Response time (Wired synchronization) [ms]	
			ON to OFF	OFF (synchronized) to ON	OFF (not synchronized) to ON	ON to OFF	OFF to ON
F3SG-4SRB0320-14-K	31	320	8	40	140	10	50
F3SG-4SRB0400-14-K	39	400	8	40	140	10	50
F3SG-4SRB0480-14-K	47	480	13	65	165	17	85
F3SG-4SRB0560-14-K	55	560	13	65	165	17	85
F3SG-4SRB0640-14-K	63	640	13	65	165	17	85
F3SG-4SRB0720-14-K	71	720	13	65	165	17	85
F3SG-4SRB0800-14-K	79	800	13	65	165	17	85
F3SG-4SRB0880-14-K	87	880	13	65	165	17	85
F3SG-4SRB0960-14-K	95	960	13	65	165	17	85
F3SG-4SRB1000-14-K	99	1000	13	65	165	17	85
F3SG-4SRB1200-14-K	119	1200	13	65	165	17	85
F3SG-4SRB1400-14-K	139	1400	13	65	165	17	85
F3SG-4SRB1600-14-K	159	1600	18	90	190	21	105
F3SG-4SRB1800-14-K	179	1800	18	90	190	21	105

Note 1. The maximum speed of movement of a test rod up to which the detection capability is maintained is 2.0 m/s.

■ Hand protection (Detection capability: 25-mm dia.)

Model	Number of beams	Protective height [mm]	Response time (Optical synchronization) [ms]			Response time (Wired synchronization) [ms]	
			ON to OFF	OFF (synchronized) to ON	OFF (not synchronized) to ON	ON to OFF	OFF to ON
F3SG-4SRB0320-25-K	16	320	8	40	140	10	50
F3SG-4SRB0400-25-K	20	400	8	40	140	10	50
F3SG-4SRB0480-25-K	24	480	8	40	140	10	50
F3SG-4SRB0560-25-K	28	560	8	40	140	10	50
F3SG-4SRB0640-25-K	32	640	8	40	140	10	50
F3SG-4SRB0720-25-K	36	720	8	40	140	10	50
F3SG-4SRB0800-25-K	40	800	8	40	140	10	50
F3SG-4SRB0880-25-K	44	880	13	65	165	17	85
F3SG-4SRB0960-25-K	48	960	13	65	165	17	85
F3SG-4SRB1000-25-K	50	1000	13	65	165	17	85
F3SG-4SRB1040-25-K	52	1040	13	65	165	17	85
F3SG-4SRB1120-25-K	56	1120	13	65	165	17	85
F3SG-4SRB1200-25-K	60	1200	13	65	165	17	85
F3SG-4SRB1280-25-K	64	1280	13	65	165	17	85
F3SG-4SRB1360-25-K	68	1360	13	65	165	17	85
F3SG-4SRB1440-25-K	72	1440	13	65	165	17	85
F3SG-4SRB1520-25-K	76	1520	13	65	165	17	85
F3SG-4SRB1600-25-K	80	1600	13	65	165	17	85
F3SG-4SRB1680-25-K	84	1680	13	65	165	17	85
F3SG-4SRB1760-25-K	88	1760	13	65	165	17	85
F3SG-4SRB1840-25-K	92	1840	13	65	165	17	85

Note 1. The maximum speed of movement of a test rod up to which the detection capability is maintained is 2.0 m/s.

1-6-2. List of Models, Current Consumption and Weight

1-6-2-1. F3SG-SR

- Finger protection (Detection capability: 14-mm dia.)

Model	Number of beams	Protective height [mm]	Current consumption [mA]		Weight [kg]	
			Emitter	Receiver	Net	Gross
F3SG-4SRA0160-14	15	160	68	106	0.4	0.8
F3SG-□SRB0160-14	15	160	69	97	0.4	0.8
F3SG-4SRA0200-14-F	19	200	71	108	0.5	0.9
F3SG-4SRB0200-14-F	19	200	70	97	0.5	0.9
F3SG-4SRA0240-14	23	240	74	111	0.6	1
F3SG-□SRB0240-14	23	240	71	98	0.6	1
F3SG-4SRA0280-14-F	27	280	77	114	0.7	1.1
F3SG-4SRB0280-14-F	27	280	73	99	0.7	1.1
F3SG-4SRA0320-14	31	320	81	117	0.8	1.2
F3SG-□SRB0320-14	31	320	74	100	0.8	1.2
F3SG-4SRA0360-14-F	35	360	84	119	0.9	1.4
F3SG-4SRB0360-14-F	35	360	75	100	0.9	1.4
F3SG-4SRA0400-14	39	400	87	122	1	1.5
F3SG-□SRB0400-14	39	400	77	101	1	1.5
F3SG-4SRA0440-14-F	43	440	90	125	1.1	1.6
F3SG-4SRB0440-14-F	43	440	78	102	1.1	1.6
F3SG-4SRA0480-14	47	480	93	128	1.2	1.7
F3SG-□SRB0480-14	47	480	79	103	1.2	1.7
F3SG-4SRA0520-14-F	51	520	96	131	1.3	1.8
F3SG-4SRB0520-14-F	51	520	81	103	1.3	1.8
F3SG-4SRA0560-14	55	560	99	133	1.4	1.9
F3SG-□SRB0560-14	55	560	82	104	1.4	1.9
F3SG-4SRA0600-14-F	59	600	103	136	1.5	2.1
F3SG-4SRB0600-14-F	59	600	83	105	1.5	2.1
F3SG-4SRA0640-14	63	640	106	139	1.6	2.2
F3SG-□SRB0640-14	63	640	85	106	1.6	2.2
F3SG-4SRA0680-14-F	67	680	109	142	1.7	2.3
F3SG-4SRB0680-14-F	67	680	86	106	1.7	2.3
F3SG-4SRA0720-14-F	71	720	112	144	1.8	2.4
F3SG-4SRB0720-14-F	71	720	87	107	1.8	2.4
F3SG-4SRA0760-14-F	75	760	115	147	1.9	2.5
F3SG-4SRB0760-14-F	75	760	89	108	1.9	2.5
F3SG-4SRA0800-14	79	800	118	150	2	2.6
F3SG-□SRB0800-14	79	800	90	109	2	2.6
F3SG-4SRA0840-14-F	83	840	121	153	2.1	2.7
F3SG-4SRB0840-14-F	83	840	91	109	2.1	2.7
F3SG-4SRA0880-14-F	87	880	124	155	2.2	2.8
F3SG-4SRB0880-14-F	87	880	93	110	2.2	2.8
F3SG-4SRA0920-14-F	91	920	128	158	2.3	3
F3SG-4SRB0920-14-F	91	920	94	111	2.3	3
F3SG-4SRA0960-14-F	95	960	131	161	2.4	3.1
F3SG-4SRB0960-14-F	95	960	95	112	2.4	3.1
F3SG-4SRA1000-14	99	1000	134	164	2.5	3.2
F3SG-□SRB1000-14	99	1000	97	112	2.5	3.2
F3SG-4SRA1200-14	119	1200	150	178	3.1	3.8
F3SG-□SRB1200-14	119	1200	103	116	3.1	3.8
F3SG-4SRA1400-14	139	1400	165	191	3.6	4.3
F3SG-□SRB1400-14	139	1400	110	120	3.6	4.3

Model	Number of beams	Protective height [mm]	Current consumption [mA]		Weight [kg]	
			Emitter	Receiver	Net	Gross
F3SG-4SRA1600-14	159	1600	181	205	4.1	4.9
F3SG-□SRB1600-14	159	1600	117	124	4.1	4.9
F3SG-4SRA1800-14	179	1800	197	219	4.6	5.5
F3SG-□SRB1800-14	179	1800	124	128	4.6	5.5
F3SG-4SRA2000-14	199	2000	212	233	5.1	6.1
F3SG-□SRB2000-14	199	2000	130	131	5.1	6.1

Note 1. The net weight is the weight of an emitter and a receiver.

Note 2. The gross weight is the weight of an emitter, a receiver, included accessories and a package.

Note 3. Calculate the current consumption when cascaded by adding up the current consumption of each model.

■ Hand protection (Detection capability: 25-mm dia.)

Model	Number of beams	Protective height [mm]	Current consumption [mA]		Weight [kg]	
			Emitter	Receiver	Net	Gross
F3SG-4SRA0160-25	8	160	63	105	0.4	0.8
F3SG-□SRB0160-25	8	160	61	96	0.4	0.8
F3SG-4SRA0200-25-F	10	200	65	108	0.5	0.9
F3SG-4SRB0200-25-F	10	200	62	96	0.5	0.9
F3SG-4SRA0240-25	12	240	68	110	0.6	1
F3SG-□SRB0240-25	12	240	63	97	0.6	1
F3SG-4SRA0280-25-F	14	280	71	112	0.7	1.1
F3SG-4SRB0280-25-F	14	280	64	97	0.7	1.1
F3SG-4SRA0320-25	16	320	74	115	0.8	1.2
F3SG-□SRB0320-25	16	320	65	97	0.8	1.2
F3SG-4SRA0360-25-F	18	360	76	117	0.9	1.4
F3SG-4SRB0360-25-F	18	360	65	98	0.9	1.4
F3SG-4SRA0400-25	20	400	79	119	1	1.5
F3SG-□SRB0400-25	20	400	66	98	1	1.5
F3SG-4SRA0440-25-F	22	440	82	121	1.1	1.6
F3SG-4SRB0440-25-F	22	440	67	98	1.1	1.6
F3SG-4SRA0480-25	24	480	84	124	1.2	1.7
F3SG-□SRB0480-25	24	480	68	99	1.2	1.7
F3SG-4SRA0520-25-F	26	520	87	126	1.3	1.8
F3SG-4SRB0520-25-F	26	520	69	99	1.3	1.8
F3SG-4SRA0560-25	28	560	90	128	1.4	1.9
F3SG-□SRB0560-25	28	560	70	99	1.4	1.9
F3SG-4SRA0600-25-F	30	600	92	131	1.5	2.1
F3SG-4SRB0600-25-F	30	600	71	100	1.5	2.1
F3SG-4SRA0640-25	32	640	95	133	1.6	2.2
F3SG-□SRB0640-25	32	640	72	100	1.6	2.2
F3SG-4SRA0680-25-F	34	680	98	135	1.7	2.3
F3SG-4SRB0680-25-F	34	680	73	100	1.7	2.3
F3SG-4SRA0720-25	36	720	100	137	1.8	2.4
F3SG-□SRB0720-25	36	720	74	101	1.8	2.4
F3SG-4SRA0760-25-F	38	760	103	140	1.9	2.5
F3SG-4SRB0760-25-F	38	760	75	101	1.9	2.5
F3SG-4SRA0800-25	40	800	106	142	2	2.6
F3SG-□SRB0800-25	40	800	76	101	2	2.6
F3SG-4SRA0840-25-F	42	840	109	144	2.1	2.7
F3SG-4SRB0840-25-F	42	840	77	101	2.1	2.7
F3SG-4SRA0880-25	44	880	111	147	2.2	2.8
F3SG-□SRB0880-25	44	880	78	102	2.2	2.8
F3SG-4SRA0920-25-F	46	920	114	149	2.3	3

Model	Number of beams	Protective height [mm]	Current consumption [mA]		Weight [kg]	
			Emitter	Receiver	Net	Gross
F3SG-4SRB0920-25-F	46	920	79	102	2.3	3
F3SG-4SRA0960-25	48	960	117	151	2.4	3.1
F3SG-□SRB0960-25	48	960	80	102	2.4	3.1
F3SG-4SRA1000-25-F	50	1000	119	154	2.5	3.2
F3SG-4SRB1000-25-F	50	1000	81	103	2.5	3.2
F3SG-4SRA1040-25	52	1040	122	156	2.6	3.3
F3SG-□SRB1040-25	52	1040	82	103	2.6	3.3
F3SG-4SRA1120-25	56	1120	127	160	2.9	3.5
F3SG-□SRB1120-25	56	1120	84	104	2.9	3.5
F3SG-4SRA1200-25	60	1200	133	165	3.1	3.8
F3SG-□SRB1200-25	60	1200	86	104	3.1	3.8
F3SG-4SRA1280-25	64	1280	138	170	3.3	4
F3SG-□SRB1280-25	64	1280	88	105	3.3	4
F3SG-4SRA1360-25	68	1360	144	174	3.5	4.2
F3SG-□SRB1360-25	68	1360	90	106	3.5	4.2
F3SG-4SRA1440-25	72	1440	149	179	3.7	4.4
F3SG-□SRB1440-25	72	1440	92	106	3.7	4.4
F3SG-4SRA1520-25	76	1520	154	183	3.9	4.7
F3SG-□SRB1520-25	76	1520	93	107	3.9	4.7
F3SG-4SRA1600-25	80	1600	160	188	4.1	4.9
F3SG-□SRB1600-25	80	1600	95	107	4.1	4.9
F3SG-4SRA1680-25	84	1680	165	192	4.3	5.2
F3SG-□SRB1680-25	84	1680	97	108	4.3	5.2
F3SG-4SRA1760-25	88	1760	170	197	4.5	5.4
F3SG-□SRB1760-25	88	1760	99	109	4.5	5.4
F3SG-4SRA1840-25	92	1840	176	202	4.7	5.6
F3SG-□SRB1840-25	92	1840	101	109	4.7	5.6
F3SG-4SRA1920-25	96	1920	181	206	4.9	5.8
F3SG-□SRB1920-25	96	1920	103	110	4.9	5.8
F3SG-4SRA2080-25	104	2080	192	215	5.3	6.3
F3SG-□SRB2080-25	104	2080	107	111	5.3	6.3
F3SG-4SRA2280-25	114	2280	205	227	5.8	6.9
F3SG-□SRB2280-25	114	2280	112	113	5.8	6.9
F3SG-4SRA2480-25	124	2480	219	238	6.3	7.4
F3SG-□SRB2480-25	124	2480	117	114	6.3	7.4

Note 1. The net weight is the weight of an emitter and a receiver.

Note 2. The gross weight is the weight of an emitter, a receiver, included accessories and a package.

Note 3. Calculate the current consumption when cascaded by adding up the current consumption of each model.

■ Arm/leg protection (Detection capability: 45-mm dia.)

Model	Number of beams	Protective height [mm]	Current consumption [mA]		Weight [kg]	
			Emitter	Receiver	Net	Gross
F3SG-4SRA0240-45	6	240	60	107	0.6	1.0
F3SG-□SRB0240-45	6	240	52	95	0.6	1.0
F3SG-4SRA0400-45	10	400	71	116	1	1.5
F3SG-□SRB0400-45	10	400	56	95	1	1.5
F3SG-4SRA0560-45	14	560	82	124	1.4	1.9
F3SG-□SRB0560-45	14	560	60	96	1.4	1.9
F3SG-4SRA0720-45	18	720	93	133	1.8	2.4
F3SG-□SRB0720-45	18	720	64	96	1.8	2.4
F3SG-4SRA0880-45	22	880	104	141	2.2	2.8
F3SG-□SRB0880-45	22	880	68	97	2.2	2.8
F3SG-4SRA1200-45	30	1200	125	158	3.1	3.8
F3SG-□SRB1200-45	30	1200	75	98	3.1	3.8
F3SG-4SRA1520-45	38	1520	147	175	3.9	4.7
F3SG-□SRB1520-45	38	1520	83	99	3.9	4.7

Note 1. The net weight is the weight of an emitter and a receiver.

Note 2. The gross weight is the weight of an emitter, a receiver, included accessories and a package.

Note 3. Calculate the current consumption when cascaded by adding up the current consumption of each model.

■ Body protection (Detection capability: 85-mm dia.)

Model	Number of beams	Protective height [mm]	Current consumption [mA]		Weight [kg]	
			Emitter	Receiver	Net	Gross
F3SG-4SRA0280-85	4	280	63	111	0.7	1.1
F3SG-□SRB0280-85	4	280	50	95	0.7	1.1
F3SG-4SRA0440-85	6	440	72	120	1.1	1.6
F3SG-□SRB0440-85	6	440	52	95	1.1	1.6
F3SG-4SRA0600-85	8	600	81	128	1.5	2.1
F3SG-□SRB0600-85	8	600	54	96	1.5	2.1
F3SG-4SRA0760-85	10	760	91	136	1.9	2.5
F3SG-□SRB0760-85	10	760	56	96	1.9	2.5
F3SG-4SRA0920-85	12	920	100	145	2.3	3.0
F3SG-□SRB0920-85	12	920	58	96	2.3	3.0

Note 1. The net weight is the weight of an emitter and a receiver.

Note 2. The gross weight is the weight of an emitter, a receiver, included accessories and a package.

Note 3. Calculate the current consumption when cascaded by adding up the current consumption of each model.

1-6-2-2. F3SG-PG Series

■ Standard type for trip function (operating range of 20m)

Model	Number of beams	Beam gap [mm]	Current consumption [mA]		Weight [kg]	
			Emitter	Receiver	Net	Gross
F3SG-4PGA0670-2A	2	500	45	120	1.7	2.2
F3SG-4PGA0970-3A	3	400	55	130	2.5	3.1
F3SG-4PGA1070-4A	4	300	65	140	2.7	3.3
F3SG-4PGA1370-4A	4	400	65	140	3.5	4.2

■ Long-distance type for trip function (operating range of 70m)

Model	Number of beams	Beam gap [mm]	Current consumption [mA]		Weight [kg]	
			Emitter	Receiver	Net	Gross
F3SG-4PGA0670-2L	2	500	45	120	1.7	2.2
F3SG-4PGA0970-3L	3	400	55	130	2.5	3.1
F3SG-4PGA1070-4L	4	300	65	140	2.7	3.3
F3SG-4PGA1370-4L	4	400	65	140	3.5	4.2

■ Passive mirror type for trip function (operating range of 5m)

Model	Number of beams	Beam gap [mm]	Current consumption [mA]		Weight [kg]	
			Emitter/Receiver		Net	Gross
F3SG-4PGA0670-2C	2	500	140		1.6	2.1
F3SG-4PGA1070-4C	4	300	150		2.6	3.2
F3SG-4PGA1370-4C	4	400	150		3.3	4.0

1-6-2-3. F3SG-SR IP69K Model

■ Finger protection (Detection capability: 14-mm dia.)

Model	Number of beams	Protective height [mm]	Current consumption [mA]		Weight [kg]	
			Emitter	Receiver	Net	Gross
F3SG-4SRB0320-14-K	31	320	74	100	5.2	6.7
F3SG-4SRB0400-14-K	39	400	77	101	5.5	7.0
F3SG-4SRB0480-14-K	47	480	79	103	5.8	7.4
F3SG-4SRB0560-14-K	55	560	82	104	6.1	7.7
F3SG-4SRB0640-14-K	63	640	85	106	6.4	8.1
F3SG-4SRB0720-14-K	71	720	87	107	6.7	8.5
F3SG-4SRB0800-14-K	79	800	90	109	7.0	8.8
F3SG-4SRB0880-14-K	87	880	93	110	7.3	9.2
F3SG-4SRB0960-14-K	95	960	95	112	7.6	9.6
F3SG-4SRB1000-14-K	99	1000	97	112	7.7	9.8
F3SG-4SRB1200-14-K	119	1200	103	116	8.5	10.6
F3SG-4SRB1400-14-K	139	1400	110	120	9.2	11.5
F3SG-4SRB1600-14-K	159	1600	117	124	10.0	12.5
F3SG-4SRB1800-14-K	179	1800	124	128	10.7	13.4

■ Hand protection (Detection capability: 25-mm dia.)

Model	Number of beams	Protective height [mm]	Current consumption [mA]		Weight [kg]	
			Emitter	Receiver	Net	Gross
F3SG-4SRB0320-25-K	16	320	65	97	5.2	6.7
F3SG-4SRB0400-25-K	20	400	66	98	5.5	7.0
F3SG-4SRB0480-25-K	24	480	68	99	5.8	7.4
F3SG-4SRB0560-25-K	28	560	70	99	6.1	7.7

Model	Number of beams	Protective height [mm]	Current consumption [mA]		Weight [kg]	
			Emitter	Receiver	Net	Gross
F3SG-4SRB0640-25-K	32	640	72	100	6.4	8.1
F3SG-4SRB0720-25-K	36	720	74	101	6.7	8.5
F3SG-4SRB0800-25-K	40	800	76	101	7.0	8.8
F3SG-4SRB0880-25-K	44	880	78	102	7.3	9.2
F3SG-4SRB0960-25-K	48	960	80	102	7.6	9.6
F3SG-4SRB1000-25-K	50	1000	81	103	7.7	9.8
F3SG-4SRB1040-25-K	52	1040	82	103	7.9	9.9
F3SG-4SRB1120-25-K	56	1120	84	104	8.2	10.3
F3SG-4SRB1200-25-K	60	1200	86	104	8.5	10.6
F3SG-4SRB1280-25-K	64	1280	88	105	8.8	11.0
F3SG-4SRB1360-25-K	68	1360	90	106	9.1	11.4
F3SG-4SRB1440-25-K	72	1440	92	106	9.4	11.7
F3SG-4SRB1520-25-K	76	1520	93	107	9.7	12.1
F3SG-4SRB1600-25-K	80	1600	95	107	10.0	12.5
F3SG-4SRB1680-25-K	84	1680	97	108	10.3	12.8
F3SG-4SRB1760-25-K	88	1760	99	109	10.6	13.2
F3SG-4SRB1840-25-K	92	1840	101	109	10.9	13.5

1-6-3. Calculation of Response Time of Cascaded Segments

F3SG-SRA	X
F3SG-SRB	X
F3SG-PG-A/-L	-
F3SG-PG-C	-

The F3SG-SR can be used in cascade connection. In cascade connection, a response time is determined by the total number of beams.

If the total number of beams of all F3SG-SR's in a cascade connection is 12 or less, its response time is 7 ms (Code A)/8 ms (Code B) when the Optical Synchronization is activated and 9 ms or less when the Wired Synchronization is activated.

If the total number of beams of all F3SG-SR's in a cascade connection is 140 or less, its response time is 12 ms (Code A)/13 ms (Code B) when the Optical Synchronization is activated and 15 ms or less when the Wired Synchronization is activated. The number of beams of each F3SG-SR segment, however, must be 112 or less.

If an F3SG-SR with 113 or more beams is included in the cascade connection, its response time is 17 ms (Code A)/18 ms (Code B) when the Optical Synchronization is activated and 22 ms or less when the Wired Synchronization is activated.

 The F3SG-PG cannot be used in cascade connection.

CHECK!

The table below summarizes the relation described above.

■ Cascaded sensors in Optical Synchronization with Scan Code A

Number of beams (per single sensor)	Number of beams (total system)	Response time [ms]		
		ON→OFF	OFF (Synchronized) →ON	OFF (Not synchronized) →ON
1 to 12	1 to 12	7	35	135
1 to 112	13 to 140*	12	60	160
1 to 199	141 to 255	17	85	185

*The number of beams of each sensor segment in cascaded connection must be 112 or less.

■ Cascaded sensors in Optical Synchronization with Scan Code B

Number of beams (per single sensor)	Number of beams (total system)	Response time [ms]		
		ON→OFF	OFF (Synchronized) →ON	OFF (Not synchronized) →ON
1 to 12	1 to 12	8	40	140
1 to 112	13 to 140*	13	65	165
1 to 199	141 to 255	18	90	190

*The number of beams of each sensor segment in cascaded connection must be 112 or less.

■ Cascaded sensors in Wired Synchronization

Number of beams (per single sensor)	Number of beams (total system)	Response time [ms]	
		ON→OFF	OFF→ON
1 to 12	1 to 12	9	45
1 to 112	13 to 140*	15	75
1 to 199	141 to 255	22	110

*The number of beams of each sensor segment in cascaded connection must be 112 or less.

 ■ Scan Code Selection

 2-21. *Response Time Adjustment*

 5-2. *Dimensions*

Chapter 2 System Operation and Functions

2-1. Combination of Functions	47
2-2. Operating States	49
2-3. Mutual Interference Prevention	51
2-4. PNP/NPN Selection	55
2-5. Self-Test	56
2-6. External Test	58
2-7. Lockout Reset	60
2-8. Interlock	61
2-9. Pre-Reset	64
2-10. PSDI	67
2-11. External Device Monitoring (EDM)	70
2-12. Auxiliary Output	73
2-13. Muting	77
2-14. Override	101
2-15. Fixed Blanking	108
2-16. Floating Blanking	114
2-17. Reduced Resolution	119
2-18. Warning Zone	122
2-19. Setting Zone Adjacency Conditions	126
2-20. Operating Range Selection	128
2-21. Response Time Adjustment	130
2-22. Area Beam Indicator (ABI)	131
2-23. Designated Beam Output	134
2-24. Stable Light Threshold Adjustment	136
2-25. Incident/Ambient Light Level Monitoring	137
2-26. Lamp	138
2-27. Maintenance Information	142

2-28. Operating Status Monitoring	145
2-29. Instantaneous Block Detection	146
2-30. Setting Recovery	147
2-31. Backup/Restoration	148
2-32. IO-Link	149

WARNING

The F3SG-SR/PG must be installed, configured, and incorporated into a machine control system by a sufficiently trained and qualified person. An unqualified person may not be able to perform these operations properly, which may cause a person to go undetected, resulting in serious injury.



Make sure the Responsible Person test the operation of the F3SG-SR/PG after setting with the SD Manager 3 to verify that the F3SG-SR/PG operates as intended. Make sure to stop the machine until the test is complete. Unintended settings may cause a person to go undetected, resulting in serious injury.



2-1. Combination of Functions

Possible combinations of the F3SG-SR/PG functions are shown in the table below. The combinations in the table are available under certain conditions. The other functions can be combined without any limitations.

 The functions listed in the table below are not available for the F3SG-RE.

CHECK!

 Refer to 2-19. *Setting Zone Adjacency Conditions* for further information.

YES: Combination available

YES-C: Combination available by setting with SD Manager 3.

NO: Combination unavailable

	Fixed Blanking ^{*6}	Floating Blanking ^{*6}	Reduced Resolution ^{*6}	Muting/Override	Pre-Reset	Warning Zone ^{*6}	EDM	Interlock	Input signal linkage of ABI	Teach-in input Push-SW or external wiring ^{*6}	PSDI ^{*6}
Fixed Blanking ^{*6}	-	YES-C ^{*2}	NO	YES	NO	YES-C	YES	YES	YES-C	YES-C	YES-C
Floating Blanking ^{*6}	YES-C ^{*2}	-	NO	YES ^{*1}	NO	YES-C	YES	YES	YES-C ^{*3}	YES-C ^{*3}	YES-C ^{*3}
Reduced Resolution ^{*6}	NO	NO	-	NO	YES-C	NO	YES-C	YES-C	YES-C	YES-C	YES-C
Muting/Override	YES	YES ^{*1}	NO	-	NO	YES-C	YES	YES	NO	NO	NO
Pre-Reset	NO	NO	YES-C	NO	-	YES-C	YES	NO	NO	NO	NO
Warning Zone ^{*6}	YES-C	YES-C	NO	YES-C	YES-C	-	YES-C	YES-C	YES-C	YES-C	YES-C
EDM	YES	YES	YES-C	YES	YES	YES-C	-	YES	YES-C	YES-C	YES-C
Interlock	YES	YES	YES-C	YES	NO	YES-C	YES	-	YES-C	YES-C	NO
Input signal linkage of ABI ^{*4}	YES-C	YES-C ^{*3}	YES-C	NO	NO	YES-C	YES-C	YES-C	-	NO	NO
Teach-in input Push-SW or external wiring ^{*5*6}	YES-C	YES-C ^{*3}	YES-C	NO	NO	YES-C	YES-C	YES-C	NO	-	NO
PSDI ^{*6}	YES-C	YES-C ^{*3}	YES-C	NO	NO	YES-C	YES-C	NO	NO	NO	-

*1. This combination requires that the Floating Blanking zone covers the full detection zone and that the Muting/Override function also covers the full detection zone.

*2. When the Fixed Blanking and Floating Blanking are selected, the top or bottom beam must be included in the Fixed Blanking zone, as shown in the left figure below. It is not allowed to set the Fixed Blanking zone not to cover the top or bottom beam, as shown in the right figure below. It is also not allowed to set a Fixed Blanking zone to split a Floating Blanking zone.

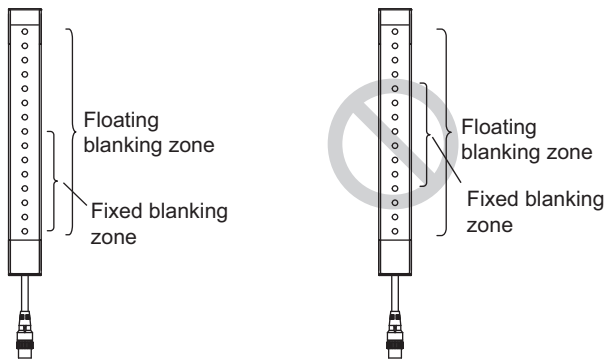

- *3. The monitoring temporarily disabling function by the external wiring of floating blanking is not usable together.
- *4. This is the function to operate the area beam indicator (ABI) using muting input A/B. For details, refer to 2-22. *Area Beam Indicator (ABI)*.
- *5. This is the function to use the teach-in input of fixed blanking or floating blanking by the [Push-SW or external wiring]. For details, refer to 4-3-2-3. *Teach-in Input*
- *6. The function is not supported by F3SG-PG.

■ Considerations for enabling and disabling Muting function with SD Manager 3

Setting parameters of the following functions is saved according to the state where the Muting function is enabled and disabled, respectively. After changing the Muting function from Enable to Disable or from Disable to Enable, check the settings of these functions again.

Affected functions:

- External Device Monitoring (EDM)
- Start Interlock
- Restart Interlock
- Auxiliary Output
- Lamp



It is recommended that the Position 2 of the DIP Switch be set at OFF (DIP Switch Disabled).



Refer to the Setting with Configuration Tool sections of the affected functions in *Chapter 2 System Operation and Functions* for more information on the setting parameters.

■ Considerations for replacing F3SG-SR/PG with the settings changed

If functions have been switched between enabled and disabled or settings have been changed with Intelligent Tap or SD Manager 3, be sure to check the settings when replacing the F3SG-SR/PG.

If any of following functions are used while still set to the factory default setting, the equipment may operate in an unexpected way.

- Interlock: Auto reset (factory default setting)
- Pre-reset and External Device Monitoring (EDM): Disabled (factory default setting)

2-2. Operating States

The following operating states exist for the F3SG-SR/PG and Intelligent Tap.

2-2-1. Operating States of F3SG-SR/PG and Intelligent Tap

■ MACHINE RUN State

The two safety outputs are in the ON state and the green OSSD indicator on the receiver is illuminated. The protected machine is allowed to operate. Pressing and releasing the reset switch has no effect.

■ MACHINE STOP State

The two safety outputs are in the OFF state and the red OSSD indicator on the receiver is illuminated. The protected machine is not allowed to operate. If connecting the sensor with the Intelligent Tap to use it, the IN and OUT indicators of the Intelligent Tap is lit up in yellow and green, respectively.

■ INTERLOCK State

The two safety outputs are in the OFF state and the yellow SEQ indicator on the receiver is illuminated. The INTERLOCK state does not allow the protected machine to operate until the detection zone is clear of obstructions and the reset switch is pressed and released.







Refer to 2-8. *Interlock* for more information.

■ LOCKOUT State

The two safety output signals is in the OFF state, and each indicator is illuminated or blinks as shown in the table below. In addition, the indicator which has detected an error is illuminated or blinks to display the error. The LOCKOUT state does not allow the protected machine to operate. The primary difference between LOCKOUT and INTERLOCK states is that the F3SG-SR/PG system will remain in the LOCKOUT state until the cause of the error is corrected, regardless of power cycling or an external reset switch press and release.

Condition	Device	Indicator	Name	Color	Illuminated	Blinking
The F3SG-SR or F3SG-PGA-L/-A is in the LOCKOUT state.	Emitter	or	Lockout	Red	Turns ON when the lockout state of other sensor being connected is detected	Flashes on the emitter side under the lockout state
	Receiver	or	Lockout	Red	Turns ON when the lockout state of other sensor being connected is detected	Flashes on the receiver side under the lockout state
		or	Maintenance	Red	LOCKOUT state due to a recoverable error (When in cascade connection, the indicator of only the sensor segment having the error is illuminated)	LOCKOUT state due to a replacement-recommended error (When in cascade connection, the indicator of only the sensor segment having the error blinks)
	Intelligent Tap	IN	Sensor status	Yellow	-	Flashes when the F3SG-SR or F3SG-PGA-L/-A is in the LOCKOUT state.
The Intelligent Tap is in the LOCKOUT state	Intelligent Tap	ERR	Lockout	Red	The Intelligent Tap is in the LOCKOUT state	-
	Receiver	or	Maintenance	Orange	-	Intelligent Tap is in the LOCKOUT state

Condition	Device	Indicator	Name	Color	Illuminated	Blinking
When F3SG-PGA-C is under lockout state	Emitter/Receiver	 or 	Lockout	Red	Turns ON when it is under the lockout state	Flashes when it is under the lockout state
		 or 	Maintenance	Red	Turns ON when the recoverable lockout occurred.	Flashes ON when the replacement-recommended lockout occurred.
	Intelligent tap	IN	Sensor status	Yellow	-	Flashing when F3SG-PGA-C is under lockout state

 Refer to 8-1-2. LOCKOUT State for more information.

■ TEACH-IN Mode

The two safety outputs are in the OFF state and the green CFG indicator on the receiver is blinking.

 Refer to 8-1-2. LOCKOUT State for more information of the error indication.

■ SETTING State

The two safety outputs are in the OFF state. In case of F3SG-SR and F3SG-PGA-A/L, the yellow TEST, green LONG and green CODE indicators on the emitter and the green CFG and green PNP and green CODE indicators on the receiver are blinking. In case of F3SG-PGA-C, the CFG, PNP, and CODE indicators of the emitter/receiver are blinking green. Then, the IN and OUT indicators of the Intelligent Tap blink in yellow and green, respectively. The SETTING state does not allow the protected machine to operate. The user can change settings of the functions, monitor the operating states or view maintenance information (Intelligent Tap, SD Manager 3 or SD Manager 3 Mobile APP) under this state.

 Refer to *Safety Light Curtain Configuration Tool for Model F3SG (SD Manager 2) User's Manual* for more information.

2-2-2. Operating States of Intelligent Tap

■ Backup

The configuration of F3SG-SR/PG is saved in the Intelligent Tap. The machine guarded cannot be operated. For the system operation and user operation method during backup, refer to 3-6-2. *Performing Backup*.

■ Restoration

The configuration in the Intelligent Tap is written into F3SG-SR/PG. The machine guarded cannot be operated. For the system operation and user operation method during restoration, refer to 3-6-3. *Performing Restoration*.

■ IO-Link Communications

While the IO-Link master and Intelligent Tap are in communication, the IO-Link indicator of the Intelligent Tap blinks in green.

2-3. Mutual Interference Prevention

⚠ WARNING

Make sure the Responsible Person tests the operation of the F3SG-SR/PG after setting with the End Cap to verify that the F3SG-SR/PG operates as intended. Make sure to stop the machine until the test is complete. Unintended settings may cause a person to go undetected, resulting in serious injury.



When using more than one set of F3SG-SR/PG's in adjacent areas, the emitter of one F3SG-SR/PG may interfere with the receiver of the other, causing the safety functions to stop working properly. Install, configure and maintain them so that mutual interference does not occur.



The F3SG-SR/PG has two types of mutual interference prevention methods, the Optical Synchronization and the Wired Synchronization. When the Optical Synchronization method is used, the F3SG-SR/PG prevents mutual interference by the Scan Code Selection. Under the wired synchronization, mutual interference is prevented by wired communications between the emitter and receiver.

2-3-1. Mutual Interference Prevention of F3SG-SR/PG

2-3-1-1. Optical Synchronization

F3SG-SRA	✓	F3SG-PGA-A	✓	F3SG-PGA-C	✓
F3SG-SRB	✓	F3SG-PGA-L	✓		

■ Overview

Synchronization is required between an emitter and a receiver for normal operation of the F3SG-SR/PG. The optical synchronization method of F3SG-SR/PG uses a specific beam to realize synchronization.



CHECK!

In case of F3SG-PGA-C, the emitter/receiver has the emitter and the receiver inside and you can select their synchronization method. If the intelligent tap is not connected to the emitter/receiver, the product operates with optical synchronization.



CHECK!

In the Optical synchronization for F3SG-SRA and F3SG-PGA-A/L, the Area Beam Indicator (ABI) of the emitter keeps off regardless of the operation of the F3SG-SR.

The beam is hereinafter called "synchronization beam".

Depending on sensor configuration, the synchronization beam is either of the followings:

- One segment system: End beams (Top or Bottom beam)
- Cascaded system*1 : End beams (Top or Bottom beam) of the primary sensor

*1. F3SG-PG cannot be cascaded.



CHECK!

By connecting the emitter and receiver with the Intelligent Tap simultaneously, the wired synchronization is configured. If using the Intelligent Tap and optical synchronization configuration together, do not connect the emitter with the Intelligent Tap.

If the intelligent tap is connected to emitter/receiver of F3SG-PGA-C, the setting becomes the wired synchronization. To operate under the optical synchronization, do not connect an intelligent tap to the F3SG-PGA-C.

For an emitter and a receiver to synchronize, at least one synchronization beam must be unblocked.

The synchronization process is performed when:

- (1) The power is turned on for an emitter and a receiver
- (2) All beams of the primary sensor are blocked and then unblocked
- (3) Synchronization is lost due to an error such as noise and ambient light



CHECK!

The sensor can maintain the synchronization in other cases than those described above and it is not necessary to keep the synchronization beam unblocked all the time.



Use the same F3SG-SR/PG models for the emitter and receiver.

[F3SG-SR and F3SG-PGA-A/-L]

■ Conditions to establish synchronization

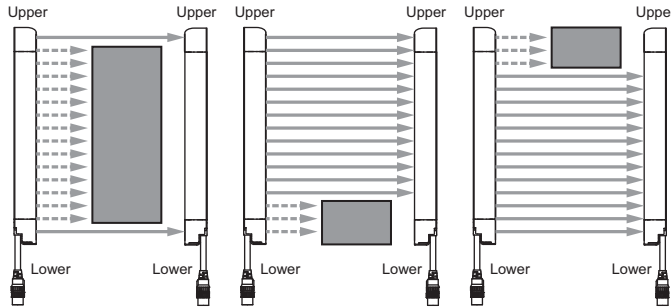

■ Conditions to fail synchronization

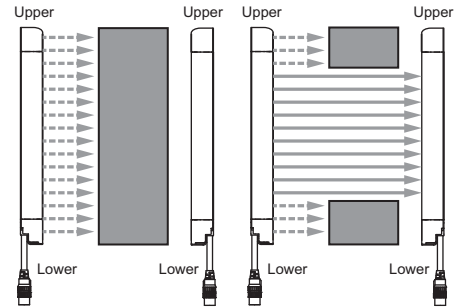

[F3SG-PGA-C]

■ Conditions to establish synchronization

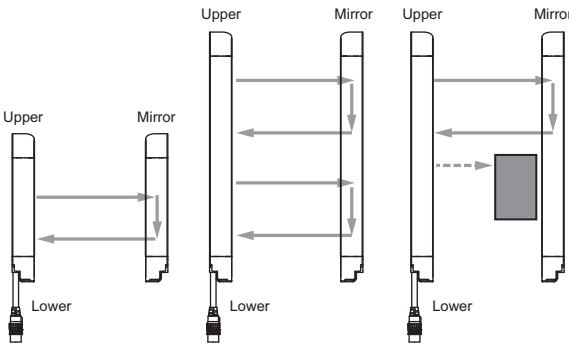

■ Conditions to fail synchronization

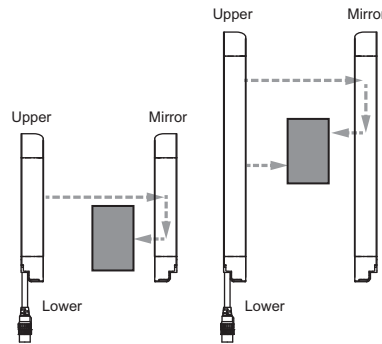

■ Response time of “OFF (Synchronized) → ON” and “OFF (Not synchronized) → ON”

Response time of “OFF (Synchronized) → ON” is the response time from when the F3SG-SR/PG is in the OFF state and the emitter and receiver are synchronized to when the F3SG-SR/PG is turned to the ON state.

Response time of “OFF (Not synchronized) → ON” is the response time from when the F3SG-SR/PG is in the OFF state and the emitter and receiver are not synchronized to when the F3SG-SR/PG is turned to the ON state. This response time is longer than that of “OFF (Synchronized) → ON” since the F3SG-SR/PG evaluates if it is blocked or unblocked, after the synchronization is established.

■ Scan Code Selection

The F3SG-SR/PG has two scan codes (Code A and Code B). These scan codes have different internal processing time. The use of different scan codes allows for placement of systems in close proximity and in line with each other and minimize mutual interference.

The response time for Code A is 1 ms shorter than that for Code B.



Refer to 1-6-1. List of Models and Response Times for more information on the response time at the time of optical synchronization setting.



Refer to 5-1-4. Mutual Interference Prevention for how to mitigate mutual interference.

■ Factory Default Setting

The factory default setting is Code A.



Both the emitter and receiver units must be set to the same code.

■ Setting with End Cap

Scan code can be set as code A or B by changing the termination cap. The termination cap for functional setting is attached on the TOP side. To change the scan code, replace the terminal cap before installing F3SG-SR/PG. Replace the termination cap after turning OFF the power. In the Wired Synchronization*, selecting a scan code is unnecessary. When using the F3SG-SR in cascade connection, make sure to attach the End Cap to the secondary sensor farthest from its power supply.

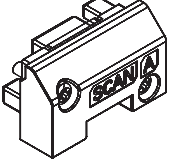
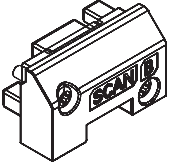
End Cap	Description	Color
	Scan Code A (factory default setting)	Black
	Scan Code B	White

* In the Wired Synchronization, F3SG-SR can prevent mutual interference in up to 3 sets.

Loosen the fixing screws (at 2 locations) of the End Cap connected near the "TOP" mark of the F3SG-SR/PG and remove the End Cap as shown below. Connect the replacing End Cap to the F3SG-SR/PG and tighten the fixing screws to fix the End Cap. The recommended torque to tighten the Mounting Screws is 0.35 N·m.

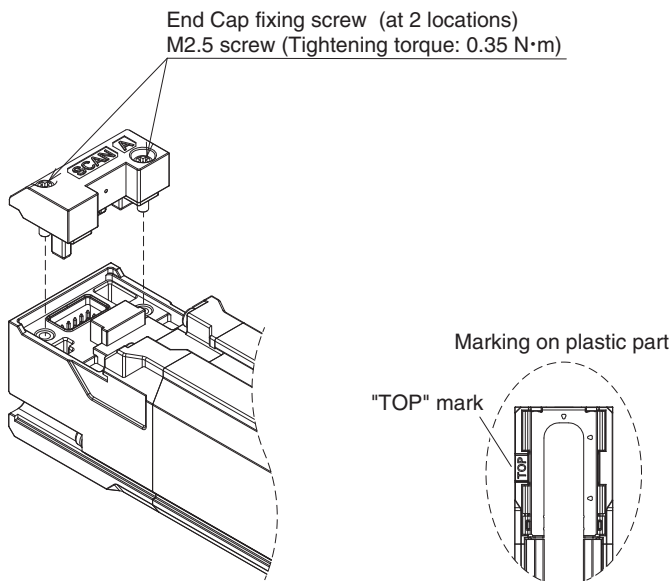

CHECK!

- Do not remove the insulating rubber attached to the End Cap. Failure to do so may cause deterioration of the protective functions.
- When attaching the End Cap, tightly fasten the screw (M2.5, recommended torque: 0.35 N·m). Failure to do so may cause the End Cap to come loose, leading to deterioration of the protective functions.
- The insulating rubber attached to connector of the End Cap may come off when removing the End Cap. If the rubber comes off, place it back to the groove of the connector and insert the connector to the sensor body.
- Change only the End Cap on the emitter/receiver for F3SG-PGA-C.

■ Setting with Lamp (optional: F39-SGLPT)

Using the rotary switch of the lamp, you can configure the scan code to either code A or B.

For how to configure, refer to 2-26-1. *Functional Description* ■ *Scan Code Switching by Lamp on Optical Synchronization*.

■ Setting with SD Manager 3

The user cannot make any changes to the settings of this function by the SD Manager 3.

2-3-1-2. Wired Synchronization

F3SG-SRA	✓	F3SG-PGA-A	✓	F3SG-PGA-C	✓
F3SG-SRB	✓	F3SG-PGA-L	✓		

■ Overview

Synchronization is required for between an emitter and a receiver for normal operation of the F3SG-SR/PG. The Wired Synchronization for F3SG-SR/PG is realized by wired communication between an emitter and a receiver. In the Wired Synchronization setting, in up to three sets of the F3SG-SR/PG can prevent mutual interference.



CHECK!

In case of F3SG-PGA-C, the emitter/receiver has the emitter and the receiver inside and you can select their synchronization method. If the intelligent tap is connected to the emitter/receiver, the product operates with wired synchronization.



CHECK!

The Mutual Interference Prevention does not work between the F3SG-SR/PG in the Optical Synchronization and the F3SG-SR/PG in the Wired Synchronization.



Refer to 1-6-1. *List of Models and Response Times* for more information on the response time.



Refer to 5-1-4. *Mutual Interference Prevention* for more information on the Mutual Interference Prevention.

There are two ways to operate the F3SG-SR or F3SG-PGA-A/L in the Wired Synchronization setting.

- 1) Connect the emitter and the receiver with the Intelligent Tap.
- 2) Connect the COM(+) and COM(-) lines of the emitter and receiver with each other.

To operate the F3SG-PGA-C with the wired synchronization, connect the emitter/receiver to the intelligent tap.

In case of F3SG-SR/F3SG-PGA-A/L, the COM(+) and MUTE A use the same line and so do the COM(-) and MUTE B. If you use the Muting and the Wired Synchronization, make sure to connect the F3SG-SR/PG with the Intelligent Tap.

In the Wired Synchronization setting of F3SG-SRA/F3SG-PGA-A/L, the Area Beam Indicator (ABI) of the emitter can be linked with that of the receiver.



CHECK!

The F3SG-SR in the Wired Synchronization setting also requires the connection with the End Cap. Connect the emitter and the receiver with the End Cap with the same code before power on.

2-4. PNP/NPN Selection

F3SG-SRA	✓	F3SG-PGA-A	✓	F3SG-PGA-C	✓
F3SG-SRB	✓	F3SG-PGA-L	✓		

2-4-1. Overview

The F3SG-SR has the PNP/NPN Selection function for the user to select the polarity of the inputs and outputs between PNP and NPN by changing the wiring. When the F3SG-SR system is set to PNP, the PNP indicator is illuminated in green.

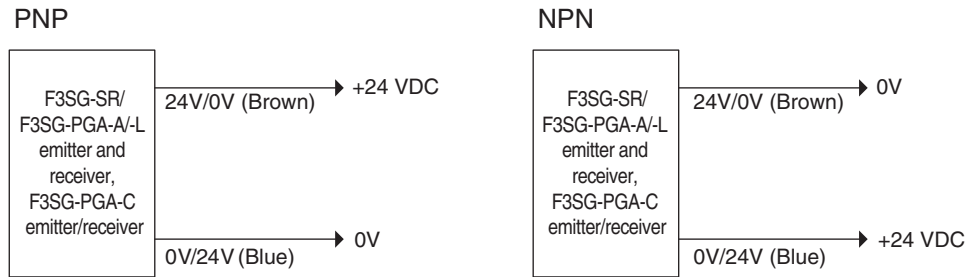

The F3SG-SR is set to PNP when the 24V/0V line (brown) is connected to +24 VDC and the 0V/24V line (blue) to 0 V.

The F3SG-SR is set to NPN when the 0V/24V line (blue) is connected to +24 VDC and the 24V/0V line (brown) to 0 V.

When using an Intelligent Tap, wire the F39-JG□A-D sensor connected with CN2 of the Intelligent Tap in the same way as above.

2-4-2. Setting with Intelligent Tap

The user cannot make any changes to the settings of this function by the DIP Switch on the Intelligent Tap.

2-4-3. Setting with SD Manager 3

The user cannot make any changes to the settings of this function by the SD Manager 3.

2-5. Self-Test

F3SG-SRA	✓	F3SG-PGA-A	✓	F3SG-PGA-C	✓
F3SG-SRB	✓	F3SG-PGA-L	✓		

2-5-1. Overview

The F3SG-SR/PG performs the Self-Test when power is turned ON (within 3 s) to check for errors. Also, it regularly performs the Self-Test (within a response time) while operating. This function cannot be cancelled.

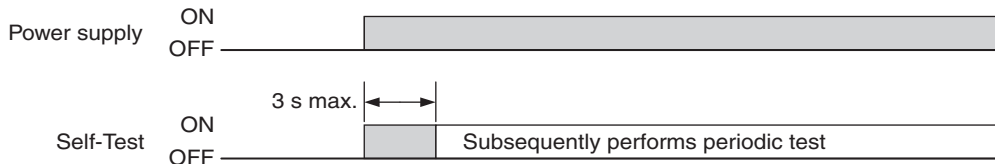

If an error is found in the Self-Test, the F3SG-SR/PG enters the LOCKOUT state, keeps the safety outputs in the OFF state, and indicates the error at the same time.

2-5-1-1. Self-Test details

The Self-Test detects such error as described below.

Emitter

- Failure of emitter unit or circuit
- CPU failure
- Memory failure

Receiver

- Abnormal external power supply voltage
- Failure of internal power supply circuit
- Failure of receiver unit or detection circuit
- CPU failure
- Memory failure
- Failure of safety output circuit
- Disconnected or short-circuited cable
- Failure of End Cap



CHECK!

In case of F3SG-PGA-C emitter/receiver, the emitter and receiver in it can respectively detect the above error.

2-5-1-2. Waveform of safety outputs

When the safety outputs are in the ON state, they are cyclically turned OFF as shown below to test the output circuit. When this OFF signal is fed back, the output circuit is diagnosed as normal. If the output signal does not include an OFF pulse signal due to short-circuit, etc, the receiver diagnoses a failure in the output circuit or wiring, and it enters the LOCKOUT state.

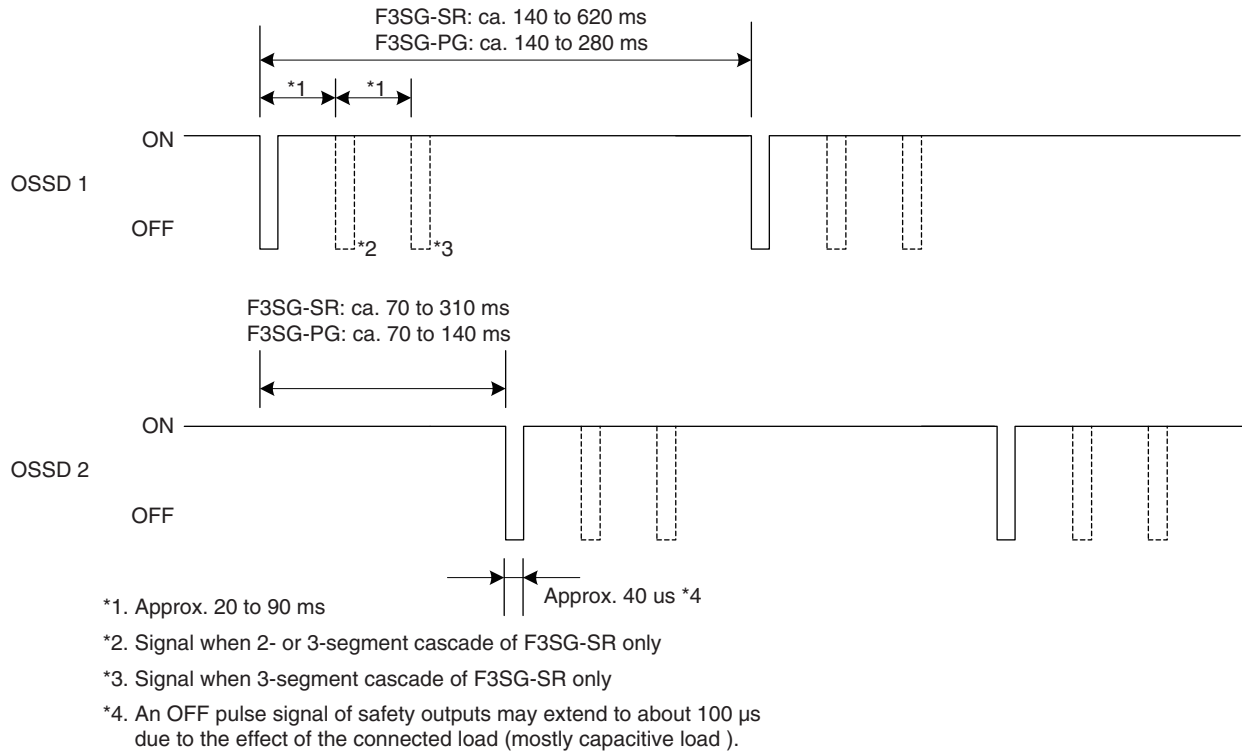

2-6. External Test

F3SG-SRA	✓	F3SG-PGA-A	✓	F3SG-PGA-C	
F3SG-SRB	✓	F3SG-PGA-L	✓		

2-6-1. Overview

This function stops the emission using an external signal. It can be used to verify that a safety system should properly stop (safety outputs turn OFF) when F3SG-SR or F3SG-PGA-A/L is blocked. To stop the emission, apply the following voltage to the emitter's TEST line.



When the Muting is active, kept ON even if the emission is stopped.

Light emission stop condition (TEST input wire)	Input voltage
Emission stops when connecting with 24 VDC.	Vs-3 to Vs
Emission stops when connecting with 0 V.	0 to 3 V

Basic wiring diagram

Emission stops when connecting with 24 VDC. (PNP) Emission stops when connecting with 0 V. (NPN)

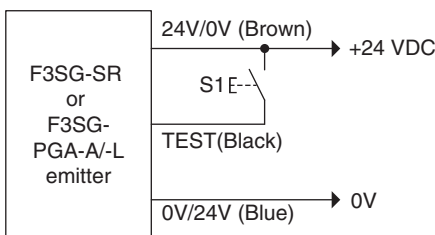

S1: Test switch (Connect the line to 0 V if this switch is not required.)

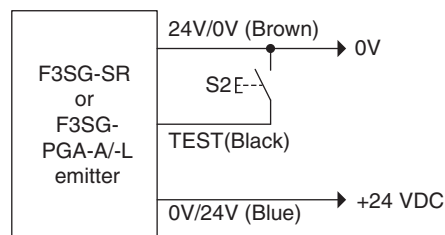

S2: Test switch (Connect the line to +24 VDC if this switch is not required.)

Timing chart

Emission stops when connected to 0 VDC:

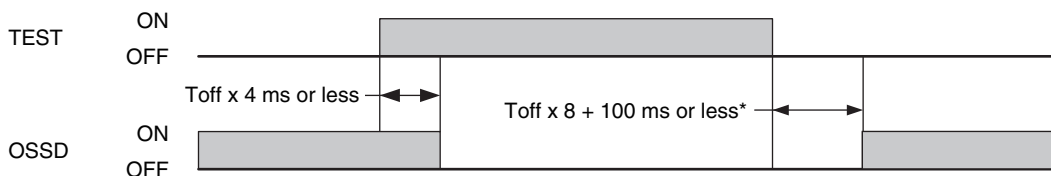

Emission stops when connected to 24 VDC:

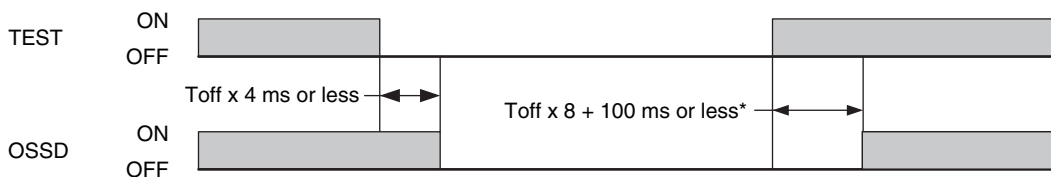

* Toffx8 + 100 ms or less is the value when the Optical Synchronization is used. When the Wired Synchronization is used, the time is Toff x 8 ms or less.

Toff: ON to OFF response time

2-6-2. Factory Default Setting

External Test Signal Inverted is disabled. The emission stop condition can be selected by setting if enabling or disabling the external test input inversion to the PNP/NPN selection. Refer to the table below.

External Test Signal Inversion *1	Emission stops condition	
	PNP setting *2	NPN setting *2
Enable (factory default setting)	Emission stops when connected to 24 VDC	Emission stops when connected to 0 VDC
Disable	Emission stops when connected to 0 VDC	Emission stops when connected to 24 VDC

*1.The user can make changes to the settings of this function by the SD Manager 3.

*2.The user can make changes to the settings of this function by wiring.

2-6-3. Setting with Intelligent Tap

This function cannot be used when connecting the Intelligent Tap to F3SG-SR or F3SG-PGA-A/-L.

2-6-4. Setting with SD Manager 3

The user can make changes to the settings of this function by the SD Manager 3.

Function name	Initial value	Configurable value
External Test Signal Inversion	Disable	Enable/Disable



It is recommended that the Position 2 of the DIP Switch be set at OFF (DIP Switch Disabled).

CHECK!



Refer to 4-3-2-4. *External Test Input* for more information on setting this function by the SD Manager 3.

2-7. Lockout Reset

F3SG-SRA	✓	F3SG-PGA-A	✓	F3SG-PGA-C	✓
F3SG-SRB	✓	F3SG-PGA-L	✓		

When the cause of the LOCKOUT state is removed, you can release the LOCKOUT state of the F3SG-SR/PG by using either of the following methods.

- Cycle the power back ON
- Reset input

The resetting method by the reset input depends on the setting of PNP/NPN Selection as follows.

PNP	NPN
Open or apply 0 V to 1/2 Vs to the RESET line (yellow) for 1 s or longer, and then apply a voltage of Vs-3 V to Vs again.	Open or apply 1/2 Vs to Vs to the RESET line (yellow) for 1 s or longer, and then apply a voltage of 0 to 3 V again.

Basic wiring diagram

- External Device Monitoring not used and in Manual Reset mode

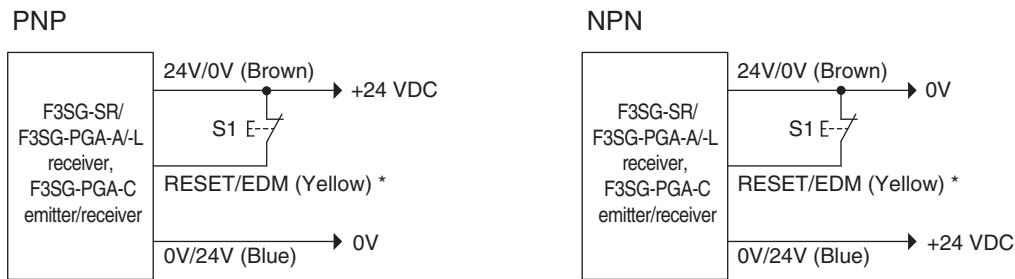

S1: Lockout or interlock reset switch

*Also used as Lockout Reset input line.

Timing chart

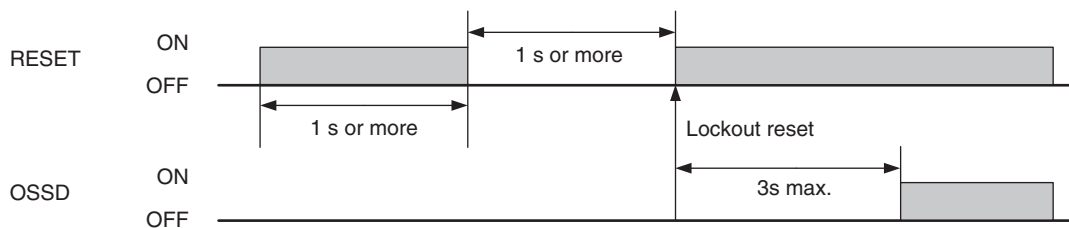

The table below shows the relation between the ON/OFF states and external lines.

Input	External connection	
	PNP	NPN
ON	Vs-3 V to Vs	0 to 3 V
OFF	0 V to 1/2 Vs, or open	1/2 Vs to Vs, or open

2-8. Interlock

WARNING

Install a protective structure so that the hazardous part of a machine can only be reached by passing through the sensor's detection zone. If access to the hazardous part by reaching over the detection zone of a vertically mounted F3SG-SR/PG cannot be excluded, the height of the detection zone and the safety distance shall be determined in consideration of such a risk. Install the sensors so that part of the person is always present in the detection zone when working in a machine's hazardous zones. If a person is able to step into the hazardous zone of a machine and remain behind the F3SG-SR/PG's detection zone, configure the system with Restart Interlock function. Failure to do so may result in serious injury due to unexpected startup.



Install the reset switch in a location that provides a clear view of the entire hazardous zone and where it cannot be activated from within the hazardous zone.



F3SG-SRA	✓	F3SG-PGA-A	✓	F3SG-PGA-C	✓
F3SG-SRB	✓	F3SG-PGA-L	✓		

2-8-1. Over view

The F3SG-SR/PG turns the safety outputs OFF when its power is turned on or the F3SG-SR/PG is blocked and holds this state until a RESET signal is received. This state is called "INTERLOCK state". The function to keep the INTERLOCK state is called "Interlock function". The SEQ indicator is illuminated in yellow in the INTERLOCK state.

The F3SG-SR/PG has two Interlock functions, Start Interlock and Restart Interlock.

- **Start Interlock**

The F3SG-SR/PG turns the safety outputs OFF at power-on or recovery from power failure and keep this state until a reset signal is received. This is useful when you keep the machine stopped until a pre-operation check is completed after the power is turned ON.

- **Restart Interlock**

The F3SG-SR/PG turns the safety outputs OFF when the F3SG-SR/PG is blocked and keep this state until a reset signal is received. Restart interlock is useful when you restart the machine being stopped upon blocking the F3SG-SR/PG, only after the operator confirms a safe condition.

The F3SG-SR/PG has three ways to reset the INTERLOCK state: Auto Reset, Manual Reset, and Pre-Reset applicable to specific applications. Refer to 2-9. *Pre-Reset* for more information.

- **Auto Reset mode**

In the Auto Reset mode, the Start Interlock and Restart Interlock are disabled. When the blocking object is removed from the detection zone, the INTERLOCK state is automatically released and the safety outputs are automatically turned ON. The Auto Reset mode is desirable for application where a worker is not able to enter the area between the detection zone and the hazardous part of the machine or you use a relay unit to activate Start Interlock and Restart Interlock.

- **Manual Reset mode**

In the Manual Reset mode, the Start Interlock and the Restart Interlock are enabled. When a reset signal is given while no blocking object exists in a detection zone, the safety outputs are turned ON.

 Refer to 2-1. *Combination of Functions* for more information on the use in conjunction with other functions.

Basic wiring diagram

- Auto Reset mode

PNP

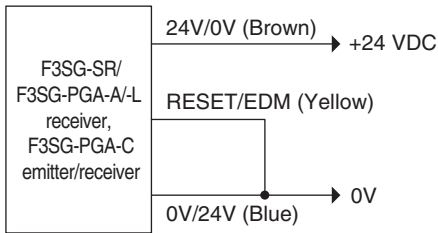

NPN

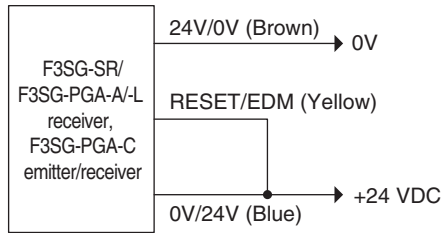

- Manual Reset mode

PNP

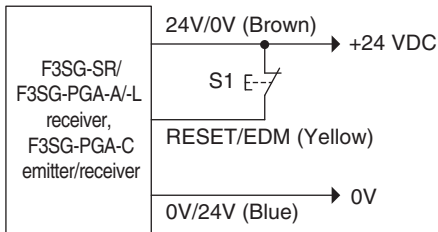

NPN

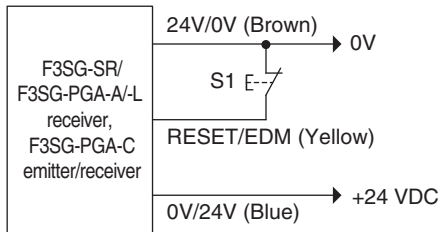

S1: Lockout or interlock reset switch

The table below shows the relation between the ON/OFF states and external lines.

Input	External Connection	
	PNP	NPN
ON	Vs-3 V to Vs	0 to 3 V
OFF	0V to 1/2 Vs, or open	1/2 Vs to Vs, or open

Timing chart

- Start Interlock

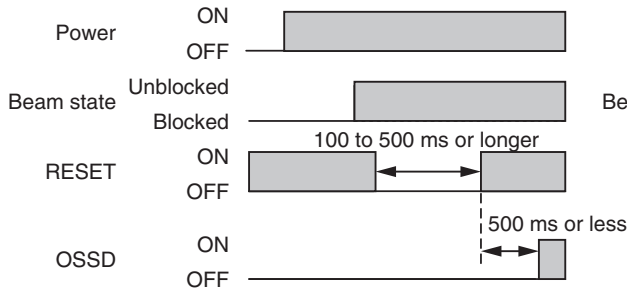

Start Interlock: Enabled

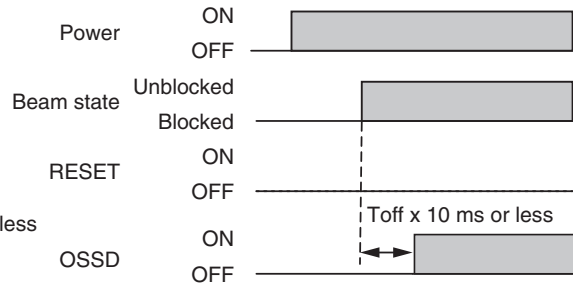

Start Interlock: Disabled

- Restart Interlock

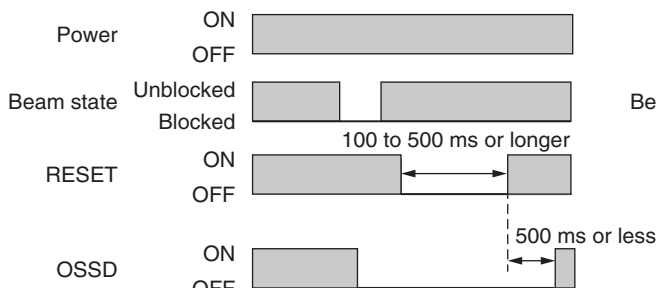

Restart Interlock: Enabled

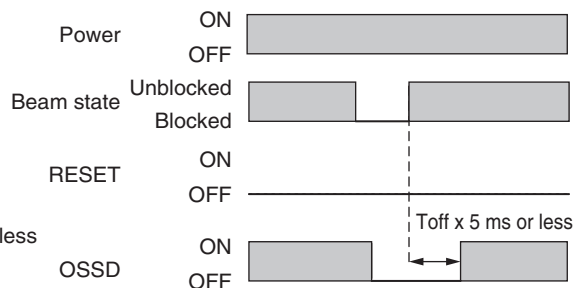

Restart Interlock: Disabled

Toff: ON to OFF response time

* The minimum pressing time of reset switch can be changed using SD Manager 3.

2-8-2. Factory Default Setting

The start interlock and restart interlock are disabled, so the sensor operates as the auto reset mode.

2-8-3. Setting with Intelligent Tap

Auto reset or manual reset can be configured using Positions 4 and 5 of the DIP Switch on the Intelligent Tap.

When the Manual Reset mode is configured, start Interlock and Restart Interlock are enabled.

Refer to 3-4. *LED Indicators on Intelligent Tap* for more information.

- Minimum pressing time of reset switch*: 100 ms (factory default setting)

* By using SD Manager 3, the time can be set by 100 ms in a range of 100 to 500 ms.



CHECK!

Make sure the Position 2 of the DIP Switch is set at ON (DIP Switch Enabled) to activate the settings by the DIP Switch.



Refer to *Chapter 3 Setting with Intelligent Tap* for more information on setting this function by the Intelligent Tap.

2-8-4. Setting with SD Manager 3

The user can make changes to the settings of this function by the SD Manager 3.

Function	Initial value		Configurable value or numerical range
	When muting enabled *	When muting disabled *	
Start interlock	Disabled	Disabled	Enabled/disabled
Restart interlock	Disabled	Disabled	Enabled/disabled
Minimum pressing time of reset switch	100 ms	100 ms	100-500 ms (by 100 ms)

* For this function, setting parameters are kept individually in each case that the muting function is set enabled or disabled. When changing of the muting state from enabled to disabled or vice versa using SD Manager 3, confirm the setting of this function again.

For details, refer to *Considerations for enabling and disabling Muting function with SD Manager 3 of 2-1. Combination of Functions*.



CHECK!

It is recommended that the Position 2 of the DIP Switch be set at OFF (DIP Switch Disabled).



Refer to 4-3-2-1. *Interlock/External Device Monitoring (EDM)/PSDI* for more information on setting this function by the SD Manager 3.

2-9. Pre-Reset

WARNING

Install the pre-reset switch always in the hazardous zone and where it cannot be activated from outside the hazardous zone.



F3SG-SRA	✓	F3SG-PGA-A	✓	F3SG-PGA-C	✓
F3SG-SRB	✓	F3SG-PGA-L	✓		

2-9-1. Overview

An operator may enter and work in the hazardous zone for maintenance.

Under such a circumstance, another operator may press the reset switch to restart the machine without recognizing the operator working in the hazardous zone, posing a danger. The Pre-Reset function ensures safety for an operator working in the hazardous zone by adding another reset switch (pre-reset switch) in the hazardous zone.

If the Pre-Reset function is enabled, an operator can work in the hazardous zone and press the pre-reset switch installed in the hazardous zone, pass the sensor, and press the reset switch to restart the machine.

Shown below is overview of restarting the machine using the Pre-Reset.

(Example of the maximum number of times the F3SG-SR can be blocked is set at 1)

1. Press the pre-reset switch. (Input a PRE-RESET signal.)
2. Pass and block the F3SG-SR/PG.
3. Press the reset switch to restart the system. (Input a RESET signal.)

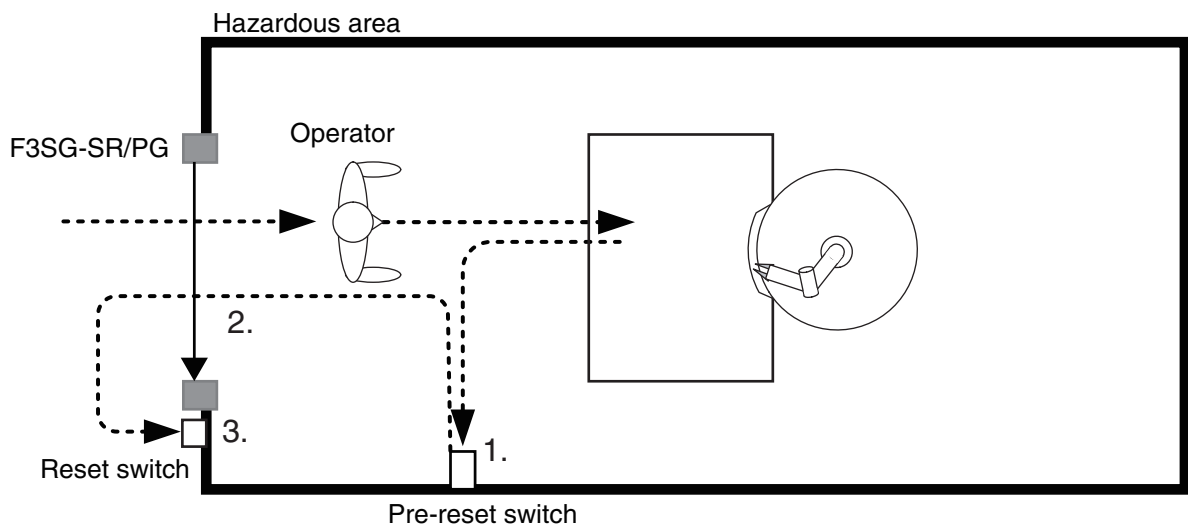

Refer to 2-1. *Combination of Functions* for more information on the use in conjunction with other functions.

Basic wiring diagram

- Pre-Reset mode

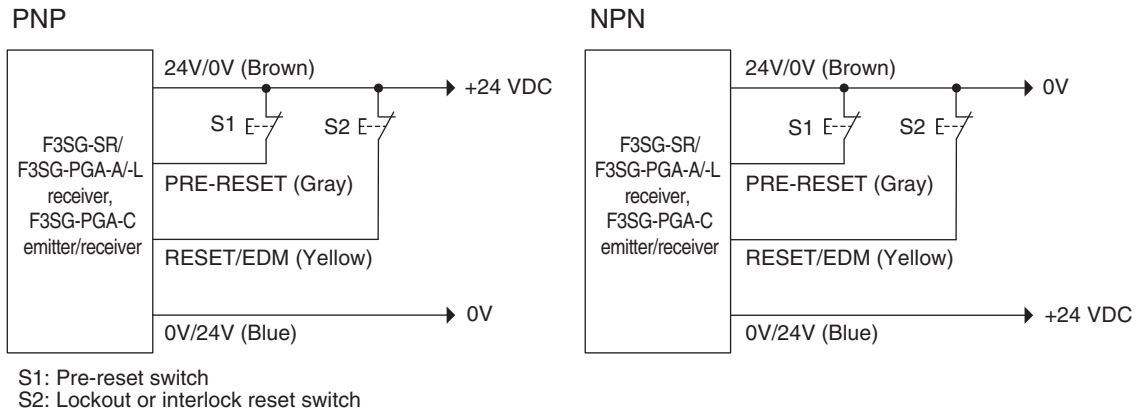

The table below shows the relation between the ON/OFF states and external lines.

Input	External connection	
	PNP	NPN
ON	Vs-3 V to Vs	0 to 3 V
OFF	0V to 1/2 Vs, or open	1/2 Vs to Vs, or open

Timing chart

This is an example of the maximum number of times the F3SG-SR/PG can be blocked is set at 1.

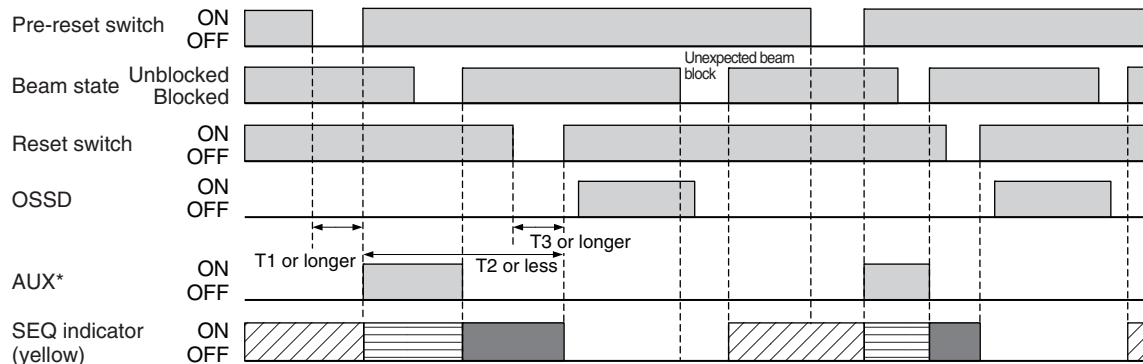

T1: Minimum pressing time of pre-reset switch. Configurable from 100 to 500 ms in 100-ms increments. T3 = T1

T2: Maximum permissible time from input of PRE-RESET signal to input of RESET signal. Configurable from 1 to 60 s in 1-s increments.

T3: Minimum pressing time of reset switch. Configurable from 100 to 500 ms in 100-ms increments.

ON 1 time ON 2 times Solid-ON

*When Auxiliary Output is set to Pre-reset Information by the SD Manager 3.

2-9-2. Factory Default Setting

The Pre-Reset function has been set to disabled.

2-9-3. Setting with Intelligent Tap

Configuring the Positions 4 and 5 of the DIP Switch on the Intelligent Tap as Pre-Reset enables the Pre-Reset mode. Refer to 3-4. *LED Indicators on Intelligent Tap* for more information.

When the Pre-Reset mode is configured, the function is activated with the following conditions:

- Minimum pressing time of the reset switch and pre-reset switch *1: 100 ms (factory default setting)
- Maximum number of times the F3SG-SR/PG can be blocked after input of PRE-RESET signal *2: Infinite (factory default setting) (The F3SG-SR/PG must be blocked at least once.)
- Maximum permissible time from input of PRE-RESET signal to input of RESET signal *3: 8 s (factory default setting)

*1 By using SD Manager 3, this parameter can be set by 100 ms in a range of 100 to 500 ms. (The minimum pressing time of the pre-reset switch is equal to that of reset switch.)

*2 By using SD Manager 3, this parameter can be set to no limit or 1 to 9 times by one time.

*3 By using SD Manager 3, this parameter can be set by 1 s in a range of 1-60 s.



CHECK!

Make sure the Position 2 of the DIP Switch is set at ON (DIP Switch Enabled) to activate the settings by the DIP Switch.



Refer to *Chapter 3 Setting with Intelligent Tap* for more information on setting this function by the DIP Switch on the Intelligent Tap.

2-9-4. Setting with SD Manager 3

The user can make changes to the settings of this function by the SD Manager 3.

Function	Initial value	Configurable value or numerical range
Pre-reset function	Disabled	Enabled/disabled
Maximum number of times F3SG can be blocked	0 (infinite)	0 (infinite) / 1-9 times (by time)
Maximum permissible time from input of PRE-RESET signal to input of RESET signal (s)	8 s	1-60 s (by the second)
Minimum pressing time of reset switch *	100 ms	100-500 ms (by 100 ms)

* Set the minimum pressing time of the reset switch and pre-reset switch. The same minimum pressing time is applied to both the switches.



CHECK!

It is recommended that the Position 2 of the DIP Switch be set at OFF (DIP Switch Disabled).



Refer to *Chapter 4 Setting with SD Manager 3* for more information on setting this function by the SD Manager 3.

2-10. PSDI

WARNING

To use the F3SG-SR in PSDI mode (initiation of cyclic operation by a presence sensing device), you must configure an appropriate circuit between the F3SG-SR and the machine. For details about PSDI, refer to OSHA 1910.217, IEC 61496-1, and other relevant standards and regulations.



F3SG-SRA	✓	F3SG-PGA-A		F3SG-PGA-C	
F3SG-SRB	✓	F3SG-PGA-L			

2-10-1. Overview

PSDI (Presence Sensing Device Initiation) is the function that F3SG-SR judges the unblocked/blocked state of the detection zone and operates the machine cyclically (repeatedly). Operations of two-hand push button switches are made unnecessary majorly on press machines, so operator's burden can be reduced and machine availability can be improved.

The following two types of PSDI can be realized without using controllers.

- Single break

The press machine of manual loading and automatic unloading is restarted in this mode by blocking of the light curtain and unblocking after that.

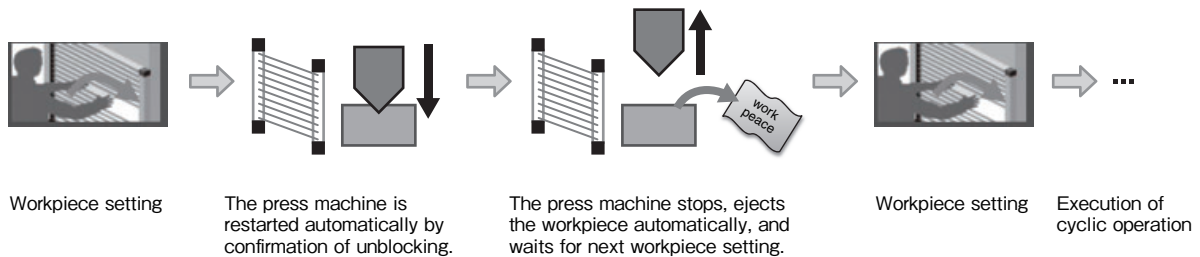

- Double break

The press machine of manual loading and manual unloading is restarted in this mode after blocking and unblocking of the light curtain is repeated twice.

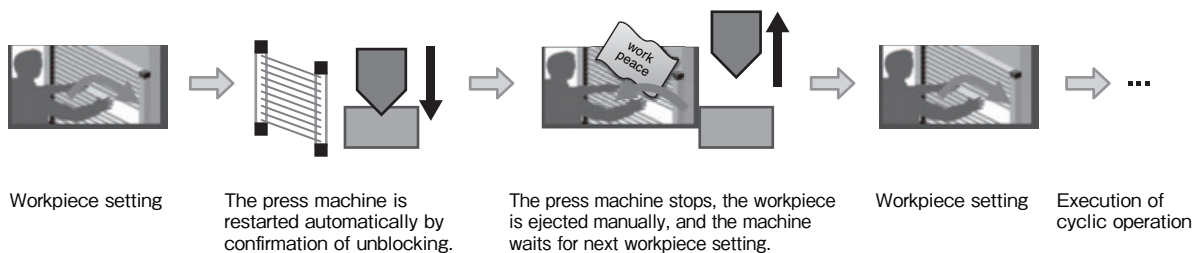

Basic wiring diagram

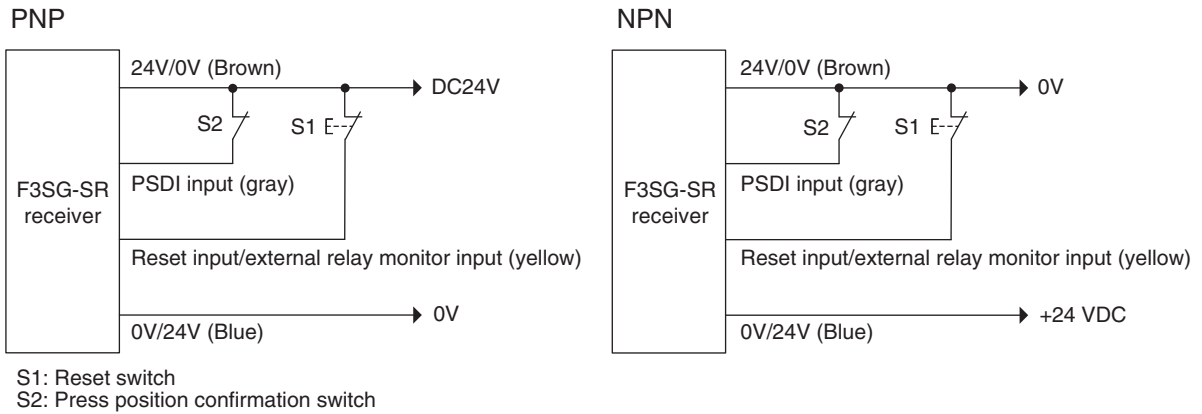

The table below shows the relation between the ON/OFF state and external connection.

Input	External connection	
	PNP	NPN
ON	Vs-3 V to Vs	0 to 3 V
OFF	0V to 1/2 Vs, or open	1/2 Vs to Vs, or open

Timing chart

Single Break

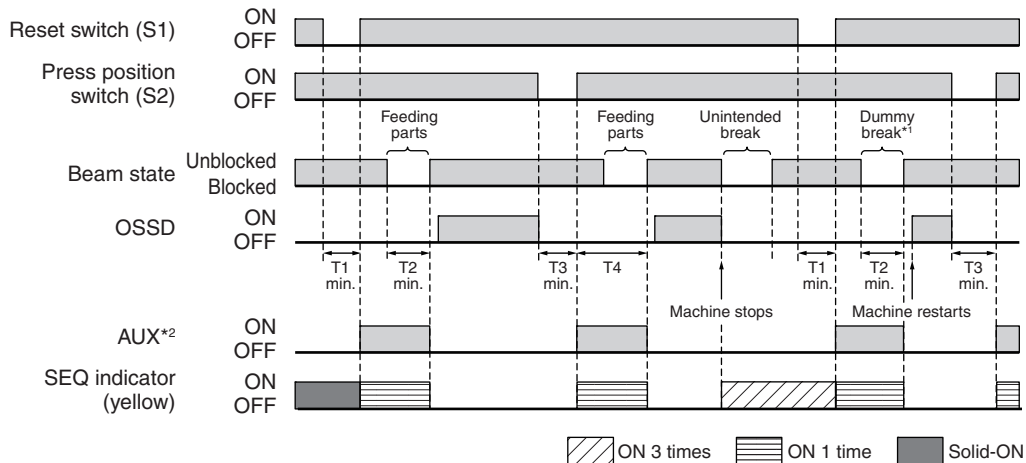

T1: Minimum pressing time of reset switch, configurable by 100 ms in a range of 100-500 ms

T2: Minimum break time (300 ms)

T3: Minimum pressing time of press position switch. T3 = T1

T4: Wait time until single break is complete (30 s or less)

*1. When the machine is stopped by unintended block in the middle of pressing of parts, operation of the reset switch (S1) and then a single dummy break are needed for reinitiation of the machine cycle.

*2. When Auxiliary Output is set to PSDI Information by the SD Manager 3.

· Double Break

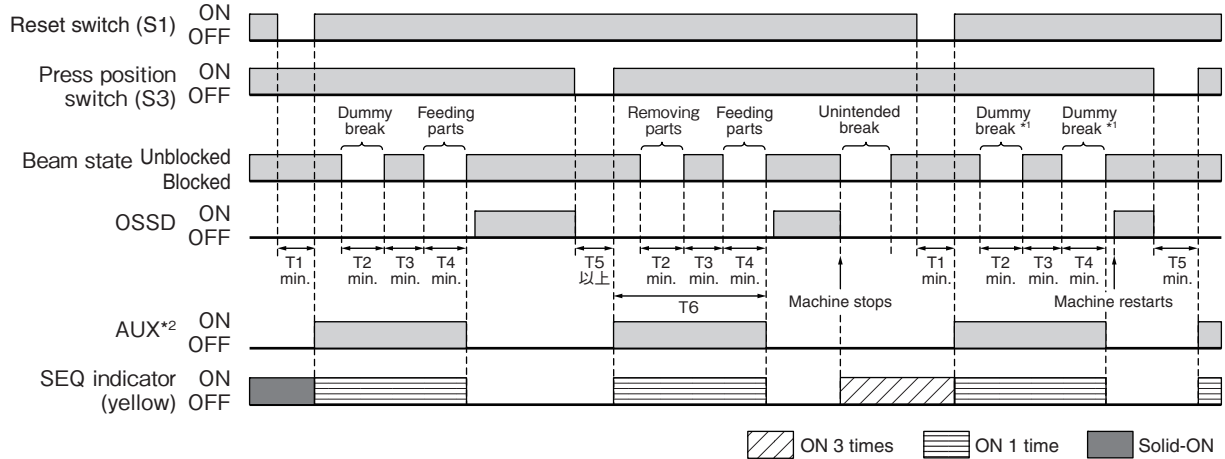

- T1: Minimum pressing time of reset switch, configurable by 100 ms in a range of 100-500 ms
- T2: Minimum break time (300 ms)
- T3: Minimum unblocked time during the time from removing to feeding parts. T3 = T1
- T4: Minimum break time (300 ms)
- T5: Minimum pressing time of press position switch. T5 = T1
- T6: Wait time until double break is complete (30 s or less)

*1. When the machine is stopped by unintended block in the middle of pressing of parts, operation of the reset switch (S1) and then double dummy break are needed for reinitiation of the machine cycle.
 *2. When Auxiliary Output is set to PSDI Information by the SD Manager 3.

2-10-2. Factory Default Setting

The PSDI function is set disabled.

2-10-3. Setting Change using Intelligent Tap

It is unable to change the setting of this function using the DIP Switch of the Intelligent Tap.

2-10-4. Setting Change using SD Manager 3

The following setting can be made using SD Manager 3.

Function	Initial value	Configurable value or numerical range
PSDI function	Disabled	Disable/Single break/Double break
Minimum pressing time of reset switch *	100 ms	100 to 500 ms in 100-ms increments

* Set the minimum pressing time of the reset switch and pre-reset switch. The same minimum pressing time is applied to both the switches.



It is recommended that the Position 2 of the DIP Switch be set at OFF (DIP Switch Disabled).

CHECK!



For the details of the setting change using SD Manager 3, refer to *Chapter 4 Setting with SD Manager 3*.

2-11. External Device Monitoring (EDM)

F3SG-SRA	✓	F3SG-PGA-A	✓	F3SG-PGA-C	✓
F3SG-SRB	✓	F3SG-PGA-L	✓		

2-11-1. Overview

This function monitors if external relays (or contactors) operate normally to detect malfunctions, such as welding, in the external relays. When the NC contact of the external relays is open before the safety outputs switch from OFF to ON, the safety outputs remain in the OFF state. When the NC contact is not open within the allowable delay time after the safety outputs switch from OFF to ON, the F3SG-SR/PG enters the LOCKOUT state.

Basic wiring diagram

Perform wiring so that the specified voltage is applied to the RESET input of F3SG-SR and F3SG-PGA-A/L receiver or F3SG-PGA-C emitter/receiver via the NC contact of the external device. Refer to the table below for the specified voltage.

The external relays or contactors must have the direct opening mechanism or be force-guided ones.

PNP/NPN	Voltage
PNP	Vs-3 V to Vs
NPN	0 V to 3 V

In Auto Reset mode

PNP

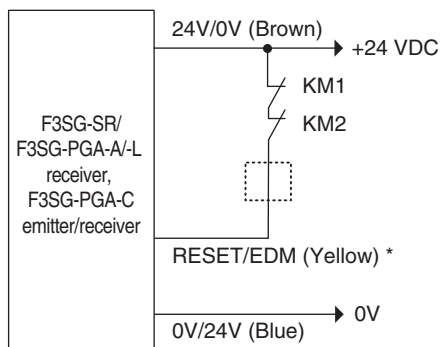

NPN

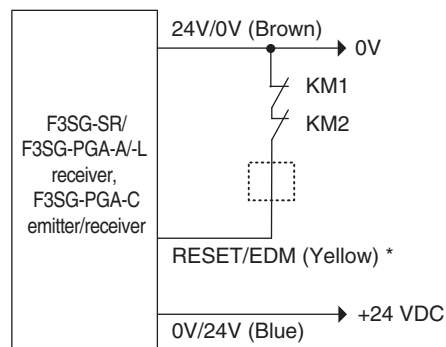

KM1, KM2: External device

*When using a lockout reset switch, connect an NC contact switch to this line in the position shown by the broken line.

In Manual Reset mode

PNP

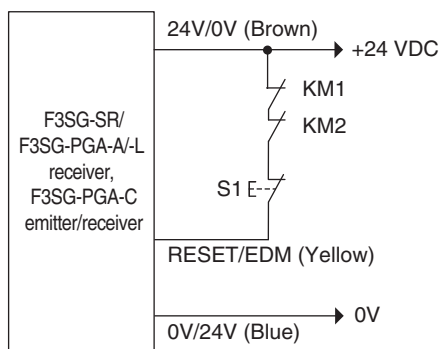

NPN

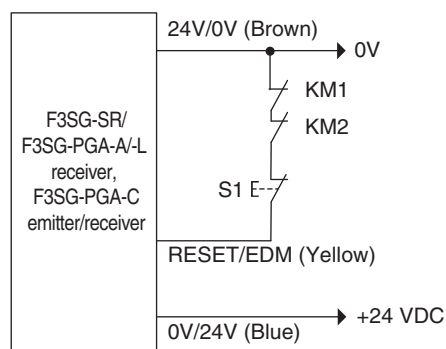

S1: Lockout or interlock reset switch
KM1, KM2: External device

■ Timing chart

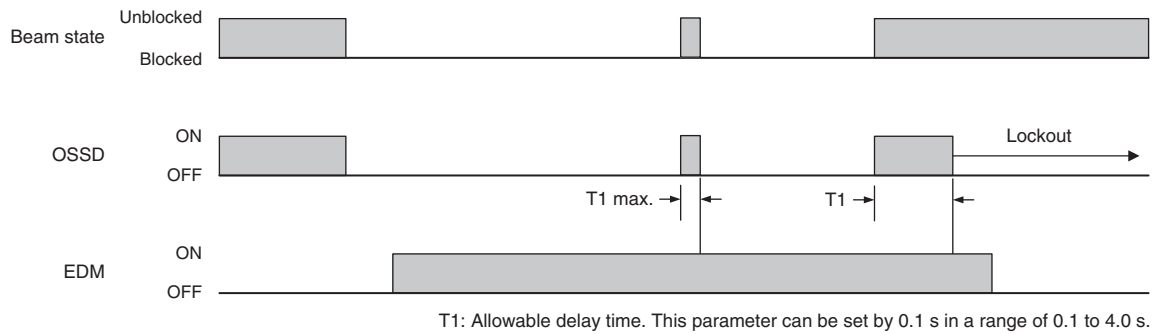

2-11-2. Factory Default Setting

The EDM function is disabled.

2-11-3. Setting with Intelligent Tap

The user can select the setting from EDM Enabled or Disabled by the DIP Switch. When enabling EDM, the function operates under the following condition.

- Allowable delay time *: 0.3 s (factory default setting)

* By using SD Manager 3, this parameter can be set by 0.1 s in a range of 0.1 to 4.0 s.



Make sure the Position 2 of the DIP Switch is set at ON (DIP Switch Enabled) to activate the settings by the DIP Switch.

CHECK!



After making the setting, make sure to perform the wiring so that the specified voltage is supplied into the RESET line of the receiver or emitter/receiver without passing through the NC contacts of the external relays, and confirm the F3SG-SR/PG enters the LOCKOUT state.

CHECK!



Refer to *Chapter 3 Setting with Intelligent Tap* for more information on setting this function by the Intelligent Tap.

2-11-4. Setting with SD Manager 3

The user can make changes to the settings of this function by the SD Manager 3.

Function	Initial value		Configurable value or numerical range
	Muting function enabled*	Muting function disabled*	
EDM	Disable	Disable	Enable/Disable
Allowable delay time	0.3 s	0.3 s	0.1 to 4 s in 0.1-s increments

* Setting parameters of this function is saved according to the states where the Muting function is enabled and disabled, respectively. After changing the Muting function from Enable to Disable or from Disable to Enable with the SD Manager 3, also check the settings of this function again.



Refer to ■ *Considerations for enabling and disabling Muting function with SD Manager 3* under 2-1. *Combination of Functions* for more information.



It is recommended that the Position 2 of the DIP Switch be set at OFF (DIP Switch Disabled).

CHECK!



After you make any change to the setting, verify that the F3SG-SR/PG goes to the LOCKOUT state when the F3SG-SR/PG is wired in such a way that the specified voltage is applied directly to the RESET line of the receiver or emitter/receiver without the NC contact of an external device.

CHECK!



Refer to 4-3-2-1. *Interlock/External Device Monitoring (EDM)/PSDI* for more information on setting this function by the SD Manager 3.

2-12. Auxiliary Output

WARNING

Do not use the output signal of the auxiliary output for safety applications. Failure to do so may result in serious injury when the F3SG-SR/PG fails.



F3SG-SRA	✓	F3SG-PGA-A	✓	F3SG-PGA-C	✓
F3SG-SRB	✓	F3SG-PGA-L	✓		

2-12-1. Overview

The Auxiliary Output is used to monitor the status of F3SG-SR/PG. This output can be connected to a device such as an indication lamp, PLC, etc.

Usage Example:

- Indicate that the F3SG-SR/PG is in the MUTING or OVERRIDE state.
- Indicate that a machine is stopped. (Safety outputs are in the OFF state.)

Basic wiring diagram

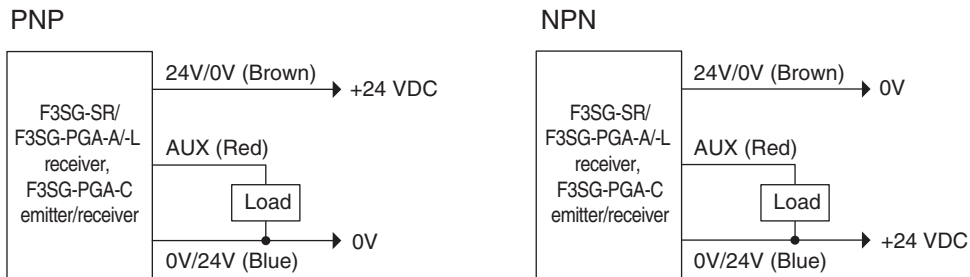

 The load current of the auxiliary output is 100 mA max.
CHECK!

2-12-2. Factory Default Setting

It is configured to the inverted signal of the safety outputs.

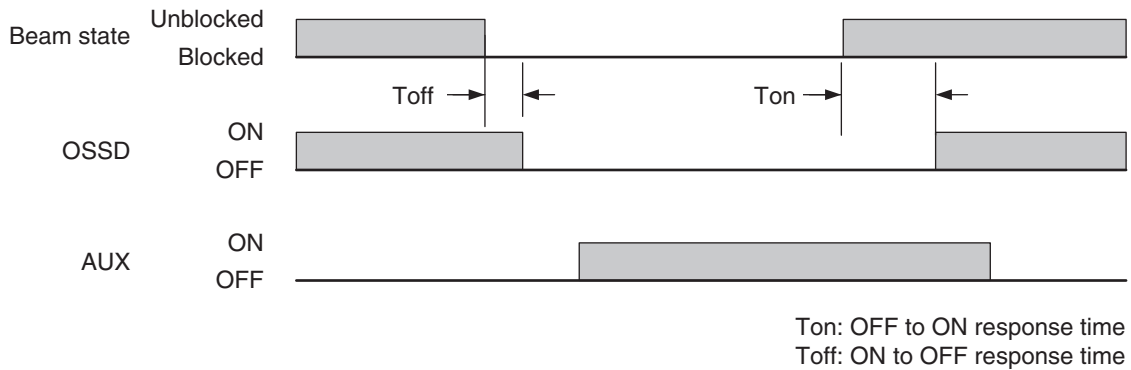

2-12-3. Setting with Intelligent Tap

The user cannot make any changes to the settings of this function by the DIP Switch on the Intelligent Tap.

When the Pre-Reset is enabled by the Dip Switch on the Intelligent Tap, the factory default setting is inverted signal of the safety outputs.

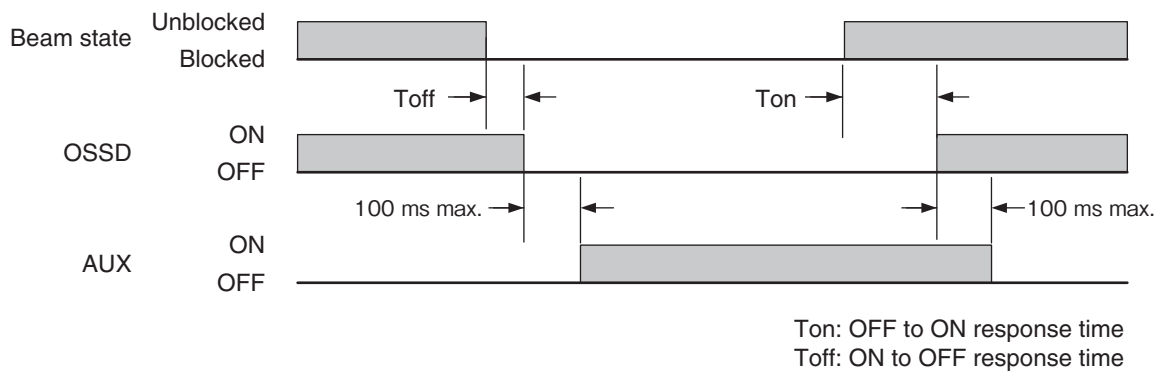

2-12-4. Setting with SD Manager 3

The user can make changes to the settings of this function by the SD Manager 3.

Function	Initial value		Configurable value or numerical range
	Muting enabled *1	Muting disabled*1	
Output operation mode	Safety output information	Safety output information	*2
Inverted signal output	Enable	Enable	Enable/Disable
Output pattern	Solid-ON	Solid-ON	Solid-ON/ON 1 time *3

*1. Setting parameters of this function is saved according to the states where the Muting function is enabled and disabled, respectively. After changing the Muting function from Enable to Disable or from Disable to Enable with the SD Manager 3, also check the settings of this function again.

 Refer to ■ *Considerations for enabling and disabling Muting function with SD Manager 3* under 2-1. *Combination of Functions* for more information.

 Refer to 2-13. *Muting* for more information on settings of the Muting function.

*2. Refer to the table of Information (Output operation mode) assigned to auxiliary output below.

*3. Output signal is sent according to the patterns as shown in the output pattern chart below.

■ Output pattern chart

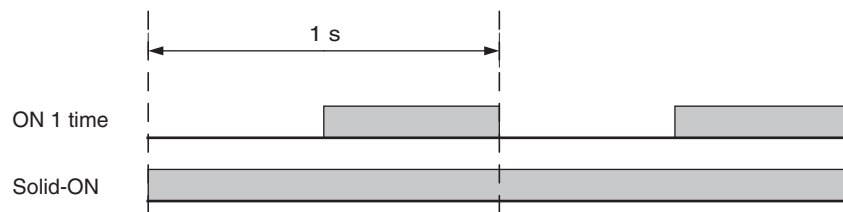

Information (Output operation mode) assigned to auxiliary output

Information Name	Description (Auxiliary output is turned ON under the following condition)
Safety output information	When the safety outputs are in the ON state
Interlock information	Under the INTERLOCK state
Lockout information	Under the LOCKOUT state
Excess power-on time information	When power-on time exceeds power-on time threshold
Excess load switching frequency information	When load switching frequency exceeds load switching frequency threshold
Stable-state information	When light intensity, which is constantly monitored, is 170% or higher of ON-threshold
Muting information	Under the MUTING state
Override information	Under the OVERRIDE state
Muting/Override information	Under either the MUTING or OVERRIDE state
Light level diagnosis information	When the F3SG-SR/PG is unblocked and light intensity is within a range from 100% to 170% of ON-threshold for 10 s or longer
Warning Zone Information*1	When warning zone is blocked
PSDI Information*1	When the F3SG-SR is ready to be blocked for feeding or removing parts
Blanking beam unblocked information	When Fixed-Blanking or Floating Blanking beams are unblocked
Troubleshooting support signal	When one of the signals of Sequence error information, instantaneous block information and Light level diagnosis information is in the ON state.
Designated beam output information	When a designated beam is blocked or unblocked
Sequence error information	Under the MUTING SEQUENCE ERROR state or the INTERLOCK SEQUENCE ERROR state
Reset-input information	When RESET/EDM/Override input is in the ON state
Mute A input signal information	When MUTE A input is in the ON state
Mute B input signal information	When MUTE B input is in the ON state
EDM input information	When EDM signal input is in the ON state
Individual cascaded sensor output (Channel 1)	When the safety outputs of the primary sensor in cascade connection are in the ON state
Individual cascaded sensor output (Channel 2)*1	When the safety outputs of the 1st secondary sensor in cascade connection are in the ON state
Individual cascaded sensor output (Channel 3)*1	When the safety outputs of the 2nd secondary sensor in cascade connection are in the ON state
Blanking/Warning-zone information*1	When Fixed Blanking, Floating Blanking, Reduced Resolution or Warning Zone function is enabled
Instantaneous block information	When the F3SG-SR/PG system stops accidentally due to interference or vibration. (In case of cascade connection, when any of cascaded segments comes under this condition.)
Pre-reset Information	Under Pre-reset state
Communication quality diagnosis information	Assigned when retry occurs in communications due to noise or short-circuit of the communication line.
Recoverable error information	Assigned when a recoverable error occurs.
Replacement-recommended error information	Assigned when a replacement-recommended error occurs.
None (OFF)	This function is disabled.

*1. Not supported by F3SG-PG.



It is recommended that the Position 2 of the DIP Switch be set at OFF (DIP Switch Disabled).

CHECK!



Refer to 4-3-3-1. *Auxiliary Output/Lamp* for more information on setting this function by the SD Manager 3.

2-13. Muting

WARNING

The Muting and Override functions disable the safety functions of the device. Especially setting the Muting Time Limit parameter to infinite may cause the safety functions to be disabled for a long time. Install the F3SG-SR/PG, muting sensor and physical barrier and configure time settings for Muting and Override so that an operator should not enter hazardous zone when the Muting and Override are active.



Install muting sensors so that they can distinguish between the object that is being allowed to pass through the detection zone and a person. If the Muting function is activated by the detection of a person, the machine may not stop operating, resulting in serious injury.



Muting lamps that indicate the state of the Muting and Override functions must be installed where they are clearly visible to workers from all the operating positions.



Use two independent input devices for muting inputs. Failure to do so may cause the MUTING state due to a single muting sensor's failure.



F3SG-SRA	✓	F3SG-PGA-A	✓	F3SG-PGA-C	✓
F3SG-SRB	✓	F3SG-PGA-L	✓		

2-13-1. Overview

Muting function temporarily disables safety function of the F3SG-SR/PG, keeping safety outputs ON even if beams are blocked. This makes it possible to install safety light curtains for AGV passage, enabling both safety and productivity. When muting is active, the area beam indicator (ABI) *1 or the TOP/BTM indicator blinks to notify people around the sensor that the safety functions are disabled.

The following three operation modes are available for the Muting function.

1. Standard Muting mode (factory default setting)
2. Exit-Only Muting mode
3. Position Detection Muting mode

*1 F3SG-SRA and F3SG-PGA-A/L/C are applicable.

*2 F3SG-SRB is applicable.



Refer to 2-1. *Combination of Functions* for more information on the use in conjunction with other functions.

The following settings are available for a beam range to be muted.

- Full zone muted (factory default setting)
- Partial zone muted

- Dynamic Muting

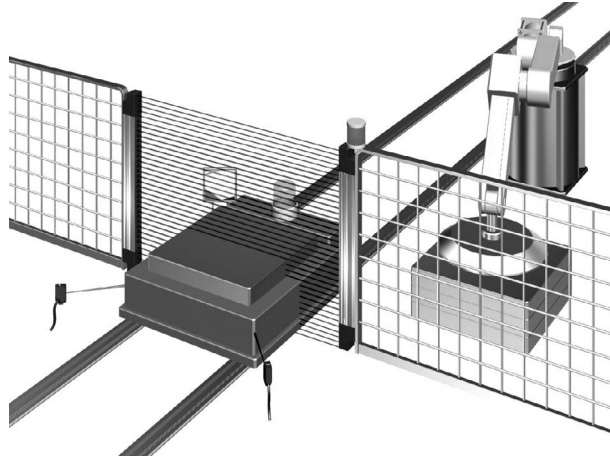

■ Using muting function

<Muting sensor>

The muting sensor is the sensor to trigger a signal to temporarily disable the safety functions of the F3SG-SR/PG. You can use a photoelectric sensor of through-beam type or reflective type proximity switch, or limit switch. (Recommended: OMRON E3Z series, E2E series (3-wire type), D4N series) Use a 3-wire type transistor output, which is the same as the output type of the F3SG-SR/PG, or NO type contact. Two-wire type sensor must not be used.

Use the Intelligent Tap to operate the F3SG-SR/PG with the Muting and the Wired Synchronization. Connect the Intelligent Tap only with the receiver of the F3SG-SR/PG to operate the F3SG-SR/PG with the Muting and the Optical Synchronization.



When the F3SG-SR/PG is in PNP settings, use the muting sensor of the PNP transistor type.
When the F3SG-SR/PG is in NPN settings, use the muting sensor of the NPN transistor type.

CHECK!

<Muting lamp>

You may need a muting lamp depending on your application or as a result of a risk assessment analysis. Before determining the use of the muting lamp, check laws and regulations of the country or region where the F3SG-SR is used and make sure of full compliance with them. For the muting lamp, use a commercially available external indicator.

The external indicator can be connected to the auxiliary output.



For settings of the auxiliary output, see 2-12. *Auxiliary Output*.

<LED indicator statuses>

Area beam indicator (ABI) *1	Blinks under the MUTING or OVERRIDE state.
TOP/BTM indicator *2	
SEQ indicator	Blinks during a muting sequence error.
CFG indicator	If the Dynamic Muting function is enabled, the indicator blinks while measuring the workpiece height.
	If the Dynamic Muting function is enabled, the indicator turns on after the new muting zone is determined.

*1 F3SG-SRA and F3SG-PGA-A/L-C are applicable.

*2 F3SG-SRB is applicable.



For muting error indication, see 8-1-3-3. *Muting Sequence Error Indication*.



For dynamic muting, see 2-13-5. *Dynamic Muting*.

<Muting zone range>

You can specify a detection zone to be muted within the detection zone of the F3SG-SR.

Muting zone range	Description
Full zone muted (factory default setting)	Full area of the detection zone is muted. This allows the safety function to be disabled in the full detection zone. This is a typical usage.
Partial zone muted	A specified area in the detection zone configured by the SD Manager 3 is muted. This can be used if you want to disable the safety function only in a specific area of the detection zone. Setting the full detection zone for the muting zone allows the full zone to be muted.
Dynamic Muting	This can be used by enabling the Dynamic Muting function. The full detection zone is muted for a certain time period from the start of the muting, then a partial zone is muted depending on the detected workpiece size.  2-13-5. Dynamic Muting

2-13-2. Standard Muting Mode

2-13-2-1. Overview

The factory default setting is set to this mode.

Turning the muting inputs A and B ON with time difference enables the Muting state.

■ Start Conditions

If both of the following two conditions are satisfied, the MUTING state is enabled.

1. No blocking object is found in the F3SG-SR/PG's detection zone, and safety outputs are ON.
2. After the muting input A is turned ON*, the muting input B is turned ON* within the range between the muting input time limit values T1min (0.1 s) and T1max (4 s). (configurable)

*PNP setting: Vs-3V to Vs, NPN setting: 0 to 3V

The MUTING state can be enabled in up to 80 ms after the condition No.2 is satisfied.

When the condition No.1 is satisfied while the time requirement of the condition No.2 is not, a muting sequence error occurs. In the case of F3SG-SR and F3SG-PGA-A/-L-C, the SEQ indicator on the receiver flashes. In the case of F3SG-PGA-C, the SEQ indicator on the emitter/receiver flashes. However, when there is a muting sequence error, the F3SG-SR/PG does not enter the MUTING state but it continues the normal operation with the safety function enabled.

 For muting error indication, see 8-1-3-3. Muting Sequence Error Indication.

The Muting error state can be released by any of following conditions:

1. Correct initial muting condition continues for 0.1 s or longer. *
2. Power cycle when the muting inputs A and B are in the OFF state.

* The correct initial muting condition is the state where the following two conditions are satisfied.

- Safety outputs of the F3SG-SR/PG are turned ON.
- Muting input A and B are turned OFF.

■ End conditions

If either of the following conditions is satisfied, the MUTING state is released.

- The muting input A or B turns OFF for the maximum allowable muting signal interruption of T3 (at least 0.1 s: configurable) or longer.
- The duration of the MUTING state exceeds the muting time limit of T2 (at least 60 s: configurable).



The MUTING state is also released when the F3SG-SR/PG enters the LOCKOUT state.

■ Timing chart

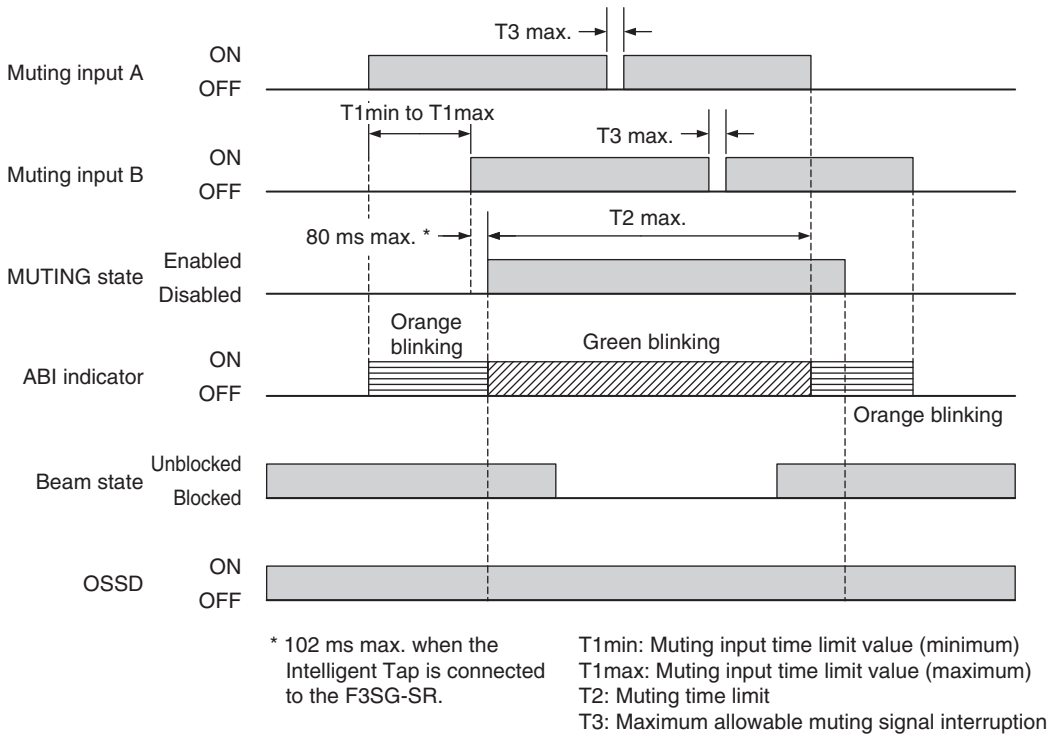

■ Factory default setting

Variable	Variable name	Value	Description
T1min	Muting input time limit value (minimum)	0.1 s	Minimum time difference between muting inputs A and B. If the time difference between muting inputs A and B is smaller than this value, a muting sequence error occurs.
T1max	Muting input time limit value (maximum)	4 s	Maximum time difference between muting inputs A and B. If the time difference between muting inputs A and B is larger than this value, a muting sequence error occurs.
T2	Muting time limit	60 s	The duration time of the Muting function. The MUTING state is cancelled if it continues for longer than this time limit.
T3	Maximum allowable muting signal interruption	0.1 s	Maximum duration of a signal interruption allowed in muting inputs A and B.

■ Basic wiring diagram

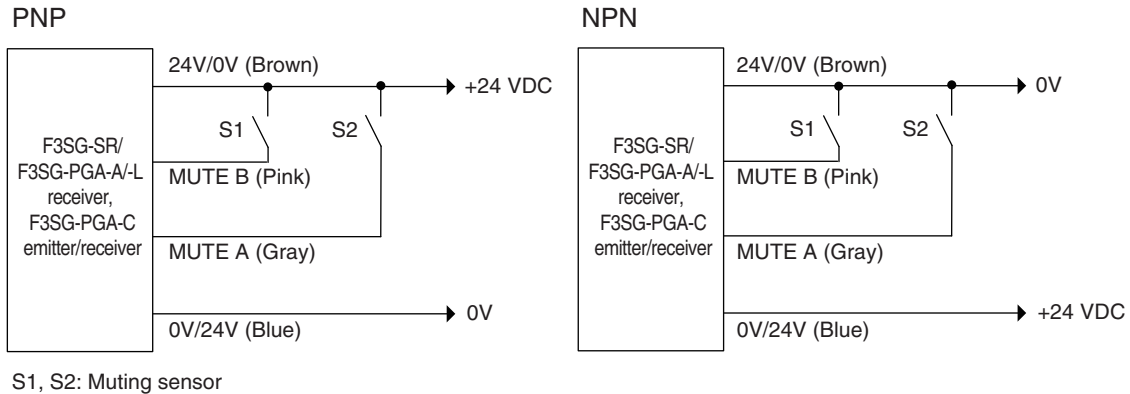

■ Installation requirements for muting sensors

- Set the muting sensors so that they can detect all of the passing detection (palettes, automobiles, etc.). Do not install the muting sensor in a position so that only the front or rear end of the objects is detected.
- Set the muting sensors so that they detect the objects even when they are loaded on palettes or other transport devices.
- Also, install the F3SG-SR/PG and muting sensors so that each object passes through all muting sensors before the next object arrives at the first muting sensor. Also, install all F3SG-SR/PGs and muting sensors so that no person is able to accidentally enter the hazardous zone while the muting function is enabled.
- If objects' speeds can vary, the allocation of muting sensors must be taken into consideration.
- Install muting sensors so that they can distinguish between the object that is being allowed to be passed through the detection zone and a person.

2-13-2-2. Installation Example 1 of Standard Muting Mode (Using Two Muting Sensors)

This is an example of two retro-reflective type photoelectric sensors used as muting sensors installed in a cross pattern.

Use two sensors when the length L of the workpieces are not constant or are insufficient.

1. Before a workpiece passes through

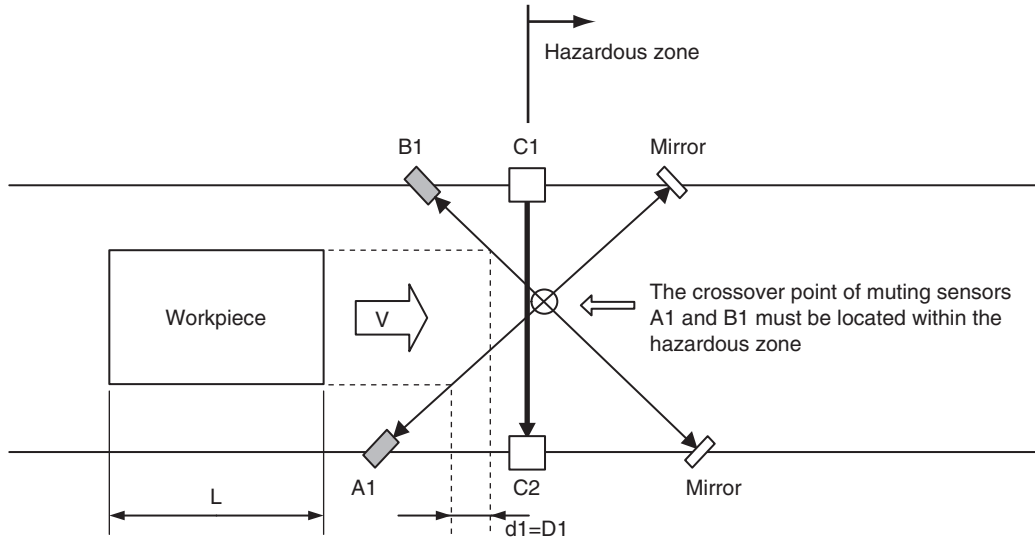

L : Length of workpiece

$d1$: Maximum distance required for the muting sensor to keep the muting function enabled

$D1$: Minimum distance required for the muting sensor to keep the muting function enabled

C1: Emitter of F3SG-SR or F3SG-PGA-A/-L or passive mirror of F3SG-PGA-C

C2: Receiver of F3SG-SR or F3SG-PGA-A/-L or emitter/receiver of F3SG-PGA-C

The output state of the muting sensors A1 and B1 are both OFF, and the safety function of the F3SG-SR/PG C1 and C2 is enabled.

In this example where two muting sensors are used, the crossover point of the muting sensors A1 and B1 is in the hazardous zone. This configuration prevents the Muting function from being enabled by a person passing through the crossover point.

2. MUTING started

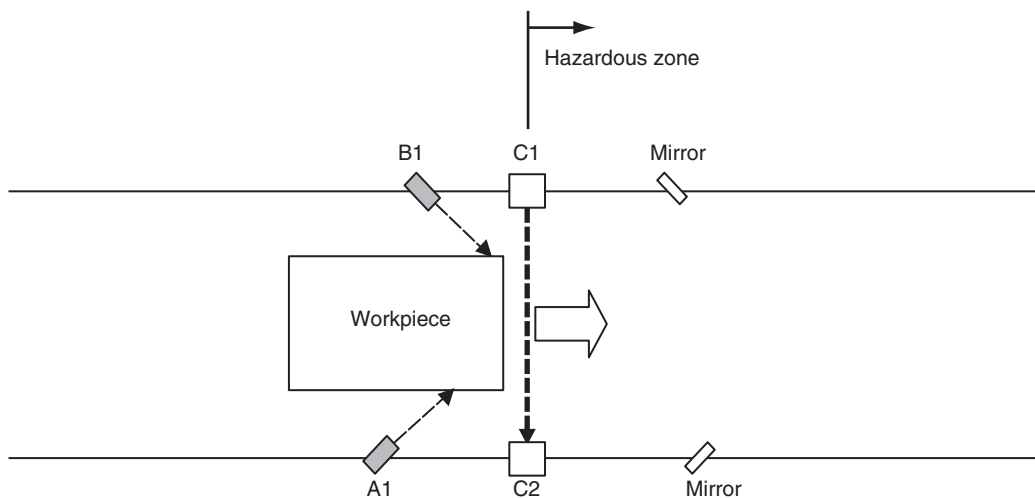

When the muting sensors A1 and B1 are turned ON in this order, the F3SG-SR enters the MUTING state. In this state, the safety function of F3SG-SR/PG C1 and C2 is disabled.

3. MUTING is maintained

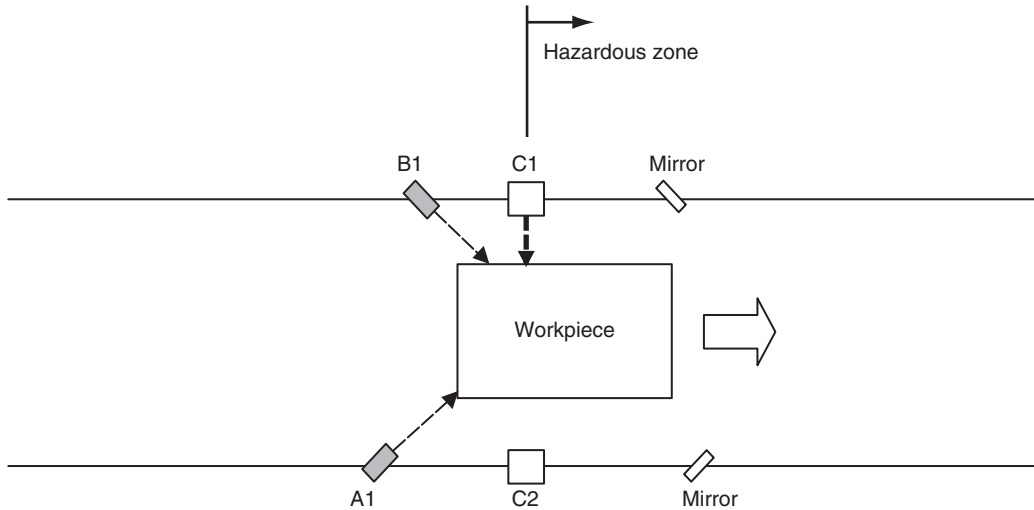

The F3SG-SR/PG C1 and C2 are blocked but the safety function is disabled due to MUTING, and the OSSD 1 and 2 are turned ON.

4. MUTING is released

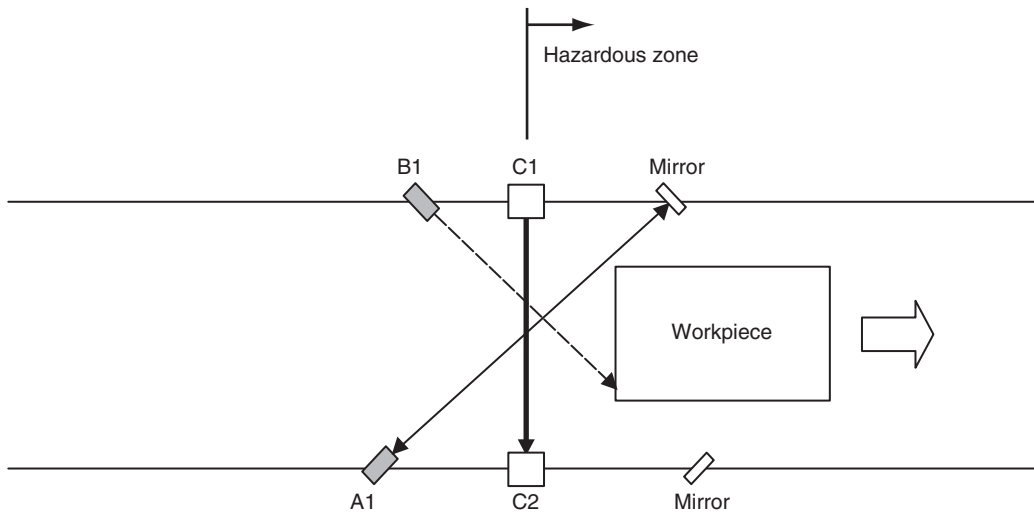

The muting sensor A1 is turned OFF, the Muting state is released, and the safety function of the F3SG-SR/PG C1 and C2 is enabled.

■ Installation distance

The minimum distance, D1 [m], required for muting sensors to keep MUTING enabled is :

$D1 < L \dots \dots$ Formula (1)
L [m]: Length of a workpiece

The maximum distance, d1 [m], required for muting sensors to keep the MUTING state enabled is :

$V \times T1min < d1 < V \times T1max \dots \dots$ Formula (2)
V [m/s]: Approach speed of a workpiece
T1min [s]: Muting input time limit value (minimum). It is set as 0.1 s. It can be changed.
T1max [s]: Muting input time limit value (maximum). It is set as 4 s. It can be changed.

To enable the MUTING state, D1 and d1 must satisfy formulas (1) and (2), respectively.

This distance must prevent the MUTING state from being enabled by a person passing through the muting sensors.

Also, install the F3SG-SR/PG and muting sensors so that each workpiece passes through all muting sensors before the next workpiece arrives at the first muting sensor.

■ Wiring diagram (PNP)

Using a photoelectric sensor as a muting sensor

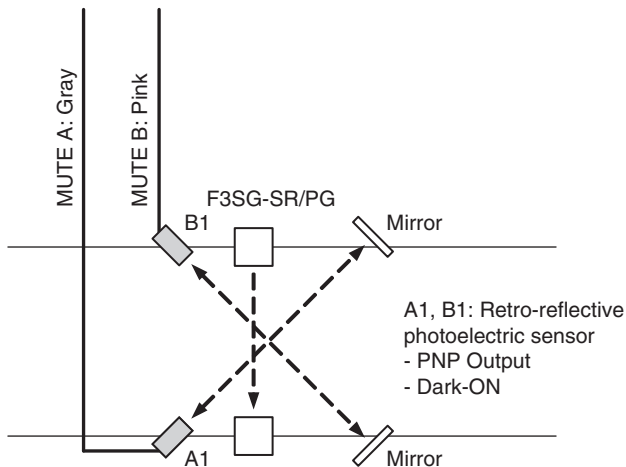

Using an NO contact type switch as a muting sensor

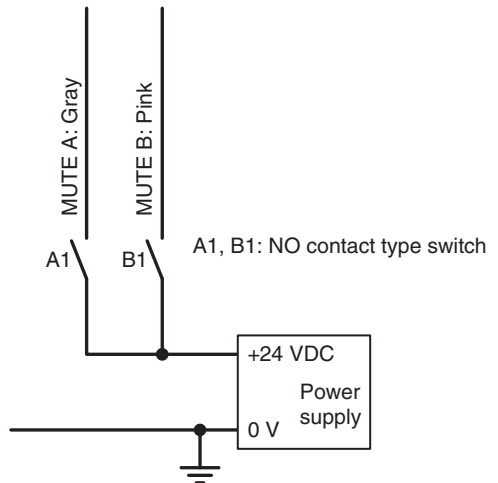

Note. Two-wire type muting sensor cannot be used.

■ Timing chart

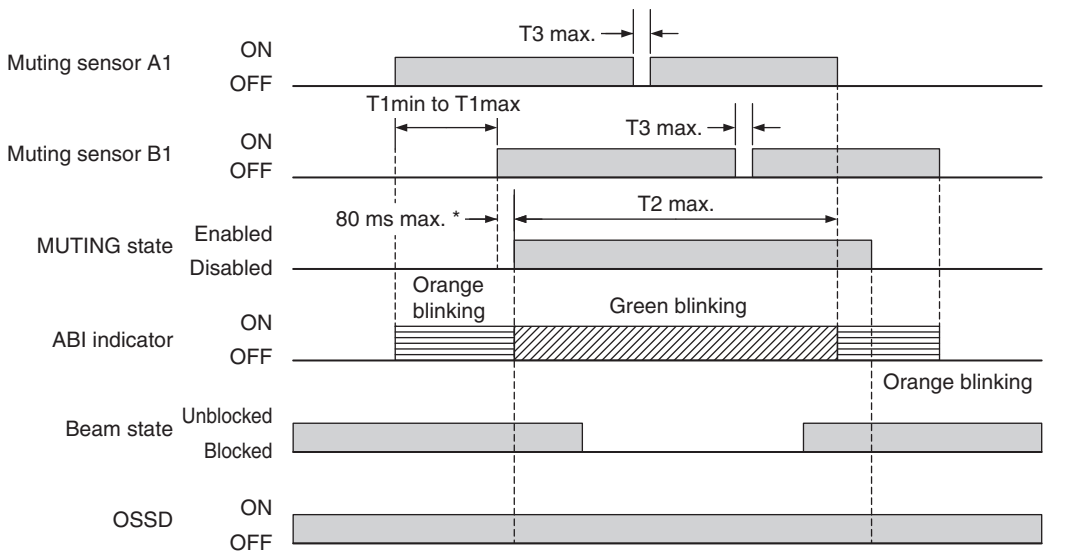

* 102 ms max. when the Intelligent Tap is connected to the F3SG-SR.

T1min: Muting input time limit value (minimum)
 T1max: Muting input time limit value (maximum)
 T2: Muting time limit
 T3: Maximum allowable muting signal interruption

Installation Example 2 of Standard Muting Mode (Using Four Muting Sensors)

This installation example uses four through-beam type photoelectric sensors as muting sensors. The use of four muting sensors is useful when the length of the workpieces is constant or longer, and the entrance and exit have enough space. Muting can be activated from both directions in the arrangement as shown below.

1. Before a workpiece passes through

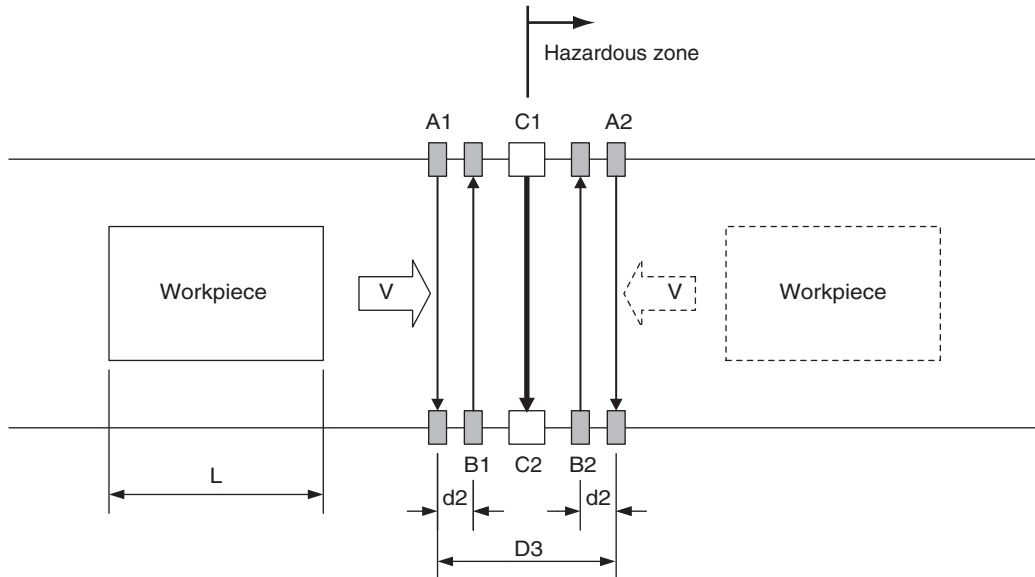

- L: Length of workpiece
- $d2$: Maximum distances required for the muting sensor to keep the muting function enabled
- $D3$: Minimum distance required for the muting sensor to keep the muting function enabled
- C1: Emitter of F3SG-SR or F3SG-PGA-A/-L or passive mirror of F3SG-PGA-C
- C2: Receiver of F3SG-SR or F3SG-PGA-A/-L or emitter/receiver of F3SG-PGA-C

All muting sensors are turned OFF, while the safety function of the F3SG-SR/PG C1 and C2 is working.

2. MUTING started

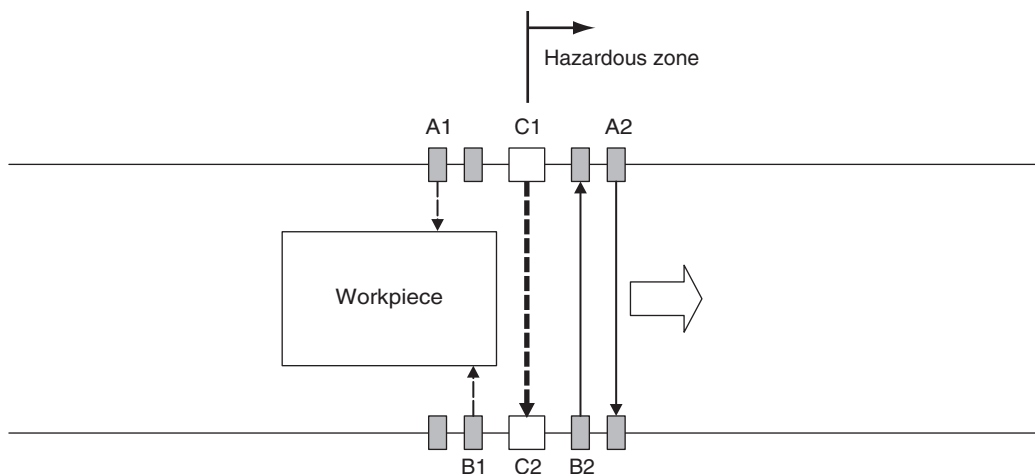

When the muting sensors A1 and B1 are turned ON in this order, MUTING starts. In this state, the safety function of F3SG-SR/PG C1 and C2 is disabled.

3. MUTING is maintained

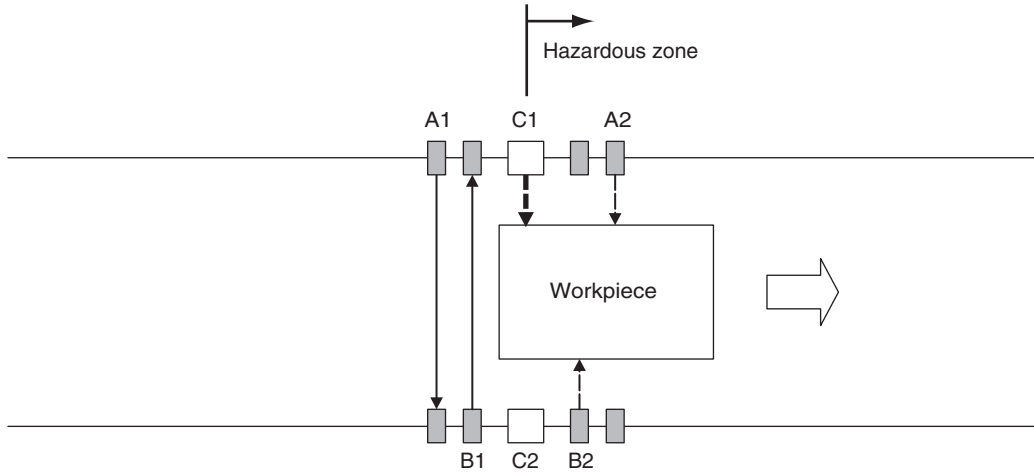

The muting sensors A1 and B1 are turned OFF but A2 and B2 are ON, so the MUTING state is still maintained. The OSSD 1 and 2 are turned ON.

4. MUTING is released

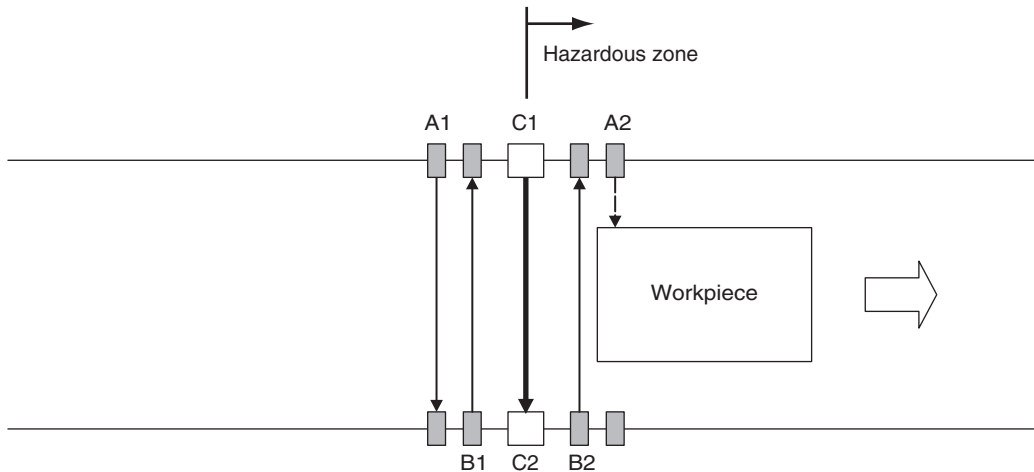

The muting sensor B2 is turned OFF, the Muting state is released, and the safety function of the F3SG-SR/PG C1 and C2 is enabled.

■ Installation distance

The minimum distance, $D3$ [m], required for muting sensors to keep MUTING enabled is :

$D3 < L$ Formula (3)

L [m]: Length of a workpiece

The maximum distance, $d2$ [m], required for muting sensors to keep MUTING enabled is :

$V \times T1min < d2 < V \times T1max$ Formula (4)

V [m/s] : Approach speed of a workpiece

$T1min$ [s] : Muting input time limit value (minimum). It is set as 0.1 s. (configurable)

$T1max$ [s] : Muting input time limit value (maximum). It is set as 4 s. (configurable)

To enable the MUTING state, D3 and d2 must satisfy formulas (3) and (4), respectively. This distance must prevent the MUTING state from being enabled by a person passing through the muting sensors. Also, install the F3SG-SR/PG and muting sensors so that each workpiece passes through all muting sensors before the next workpiece arrives at the first muting sensor.

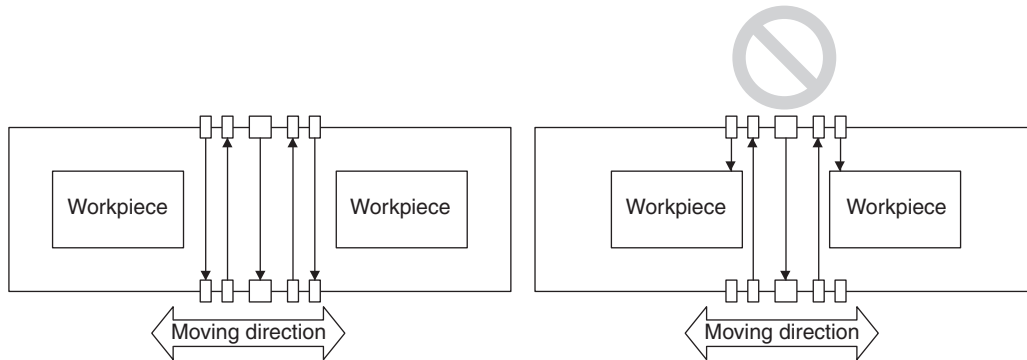

■ Wiring diagram (PNP)

Using a photoelectric sensor as a muting sensor

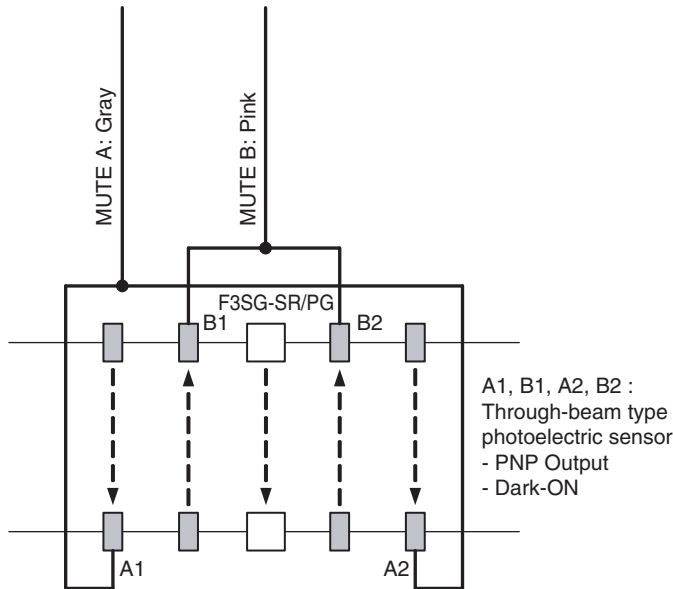

Using an NO contact type switch as a muting sensor (PNP)

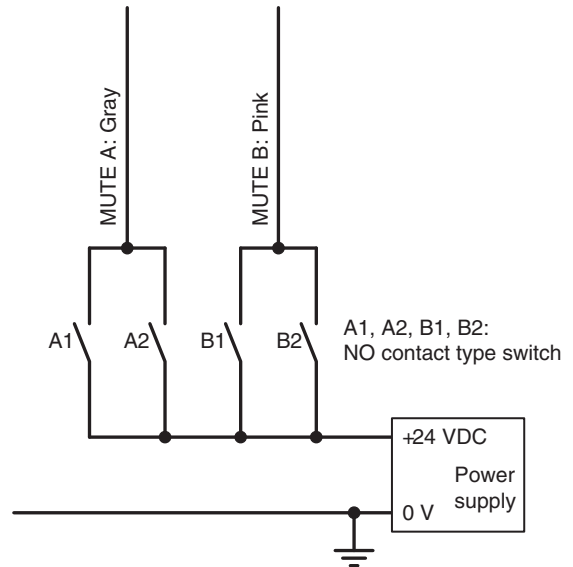

Note. Two-wire type muting sensor cannot be used.

■ Timing chart

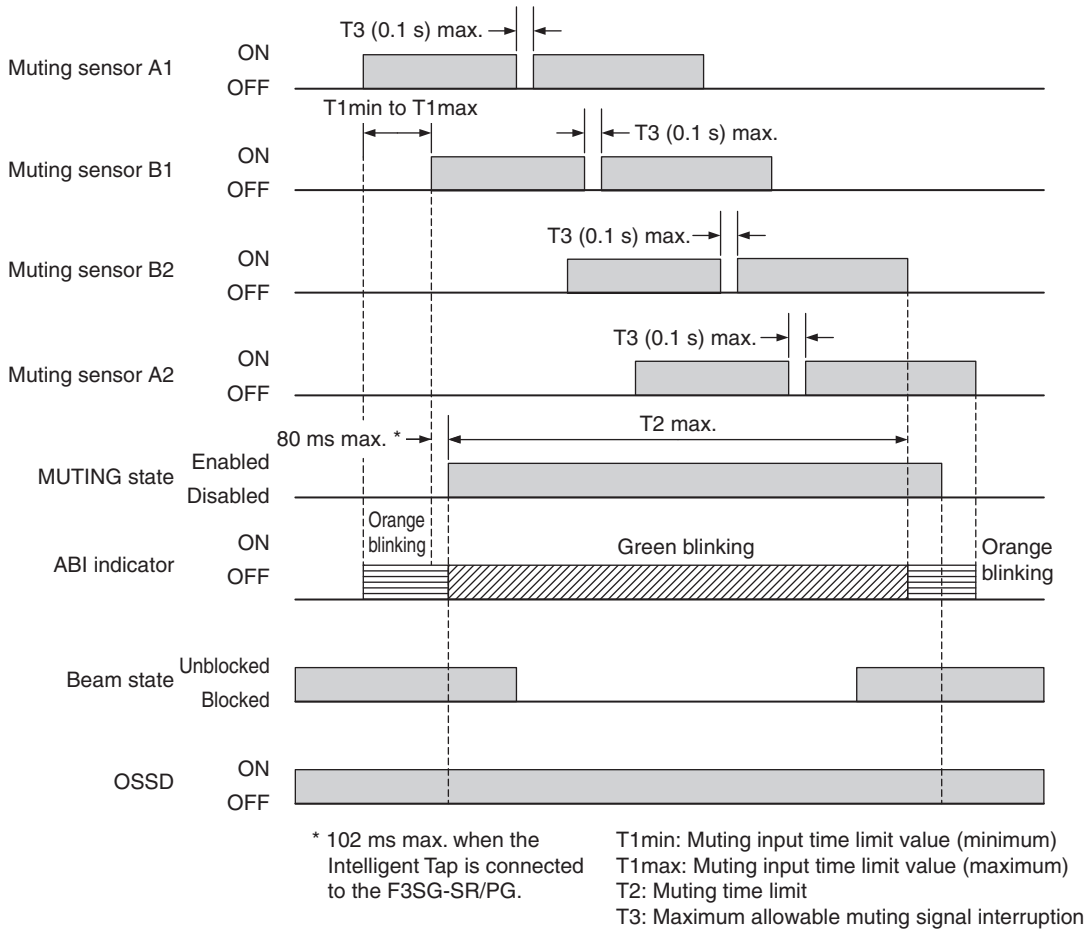

■ Preventing light interference of muting sensor

When a photoelectric sensor is used as a muting sensor, light interference may cause a muting error of the F3SG-SR/PG.

The cause and measures for light interference are shown as follows:

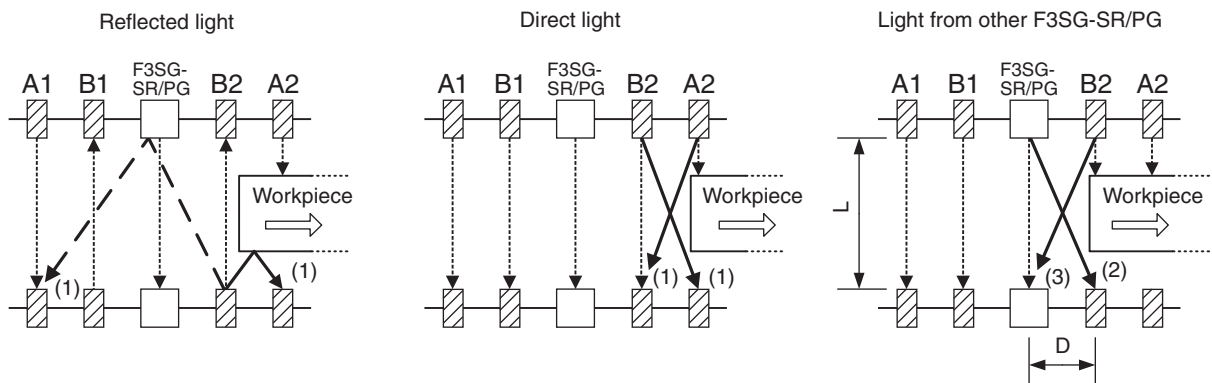

(1) Interference between muting sensors

- Use sensors with mutual interference prevention (such as retro-reflective E3Z-R□□ series)
- Use laser-type sensors (such as laser-type E3Z-LR□ series)
- Take distance from a sensor causing the interference
- Displace beams for each other to prevent interference (change installation height or place them crosswise)
- Install a physical barrier
- Attach interference prevention filter (provided for E3Z series as accessories)
- Attach a slit to reduce light intensity (provided for E3Z series as accessories)
- Lower the sensitivity

- Reduce a distance between a workpiece and a muting sensor to prevent reflected light from a workpiece
- (2) Interference to a muting sensor from the F3SG-SR/PG
 - Take distance (D) from a sensor causing the interference
 - Displace beams for each other to prevent interference (change installation height or place them crosswise)
 - Install a physical barrier
 - Arrange sensors in alternation
 - Lower the sensitivity
- (3) Interference to the F3SG-SR/PG from a muting sensor
 - Use a red LED type sensor (such as retro-reflective E3Z-R□□ series)
 - Use laser-type sensors (such as laser-type E3Z-LR□ series)
 - Take distance (D) from a sensor causing the interference
 - Displace beams for each other to prevent interference (change installation height or place them crosswise)
 - Install a physical barrier
 - Arrange sensors in alternation
 - Attach a slit to reduce light intensity (provided for E3Z series as accessories)

Mutual interference between a muting sensor and F3SG-SR/PG in (2) and (3) above can be prevented by configuring D satisfying a formula shown below:

- If $L = l$ in case of less than $3m^*1$, $D = 0.26$ m or larger
- If $L = 3$ m or larger, $D = L \times \tan 5^\circ = L \times 0.088$ m or larger

L : Distance between an emitter and a receiver of the F3SG-SR and F3SG-PGA-A/L, or distance between an emitter/receiver and passive mirror of the F3SG-PGA-C

D : Distance between a muting sensor and a F3SG-SR

*1. The product must be used within the operating range of each sensor. For the operating range, refer to 1-5. Ratings and Specifications.

2-13-3. Exit-Only Muting Mode

2-13-3-1. Overview

Turning the muting inputs A and B ON with time difference enables MUTING. Difference from Standard Muting mode exists in the muting completion condition.

■ Start conditions

If both of the following two conditions are satisfied, the MUTING state is enabled.

1. No blocking object is found in the F3SG-SR/PG's detection zone, and the safety outputs are ON.
2. After the muting input A is turned ON*, the muting input B is turned ON* within the range between the muting input time limit values T1min (0.1 s) and T1max (4 s). (configurable)

*PNP setting: $V_s - 3V$ to V_s , NPN setting: 0 to 3V

The MUTING state can be enabled in up to 80 ms after the condition No.2 is satisfied.

If the condition No.1 is satisfied but the time requirement of the condition No.2 is not, a muting error occurs, and the SEQ indicator on the receiver turns ON. However, when there is a muting error, the F3SG-SR/PG continues the normal operation with the safety function enabled.



For muting error indication, see 8-1-3-3. Muting Sequence Error Indication.

The Muting error state can be released by any of following conditions:

1. Correct initial muting condition continues for 0.1 s or longer. *
2. Power cycle when the muting inputs A and B are in the OFF state.

* The correct initial muting condition is the state where the following two conditions are satisfied.

- Safety outputs of the F3SG-SR/PG are turned ON.
- Muting input A and B are turned OFF.

■ End conditions

If any of the following condition is satisfied, the MUTING state is released.

- When a workpiece passes the muting sensor A or B and the exit-only muting delay time (4 s: Can be changed) passes.
- When a workpiece passes the F3SG-SR/PG's detection zone and the muting end wait time (1 s: configurable) passes.
- The duration of the MUTING state exceeds the muting time limit (60 s: configurable).



The MUTING state is also released when the F3SG-SR/PG enters the LOCKOUT state.

■ Timing chart

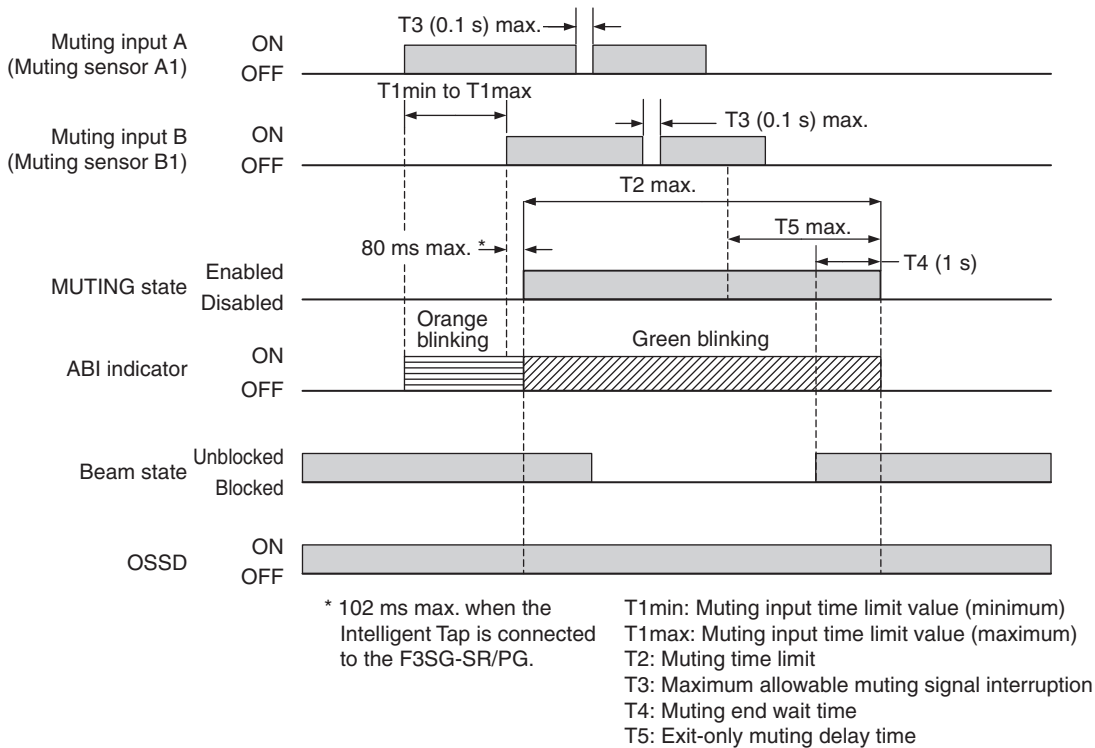

Note. This timing chart shows the case in which the MUTING state was released under the condition of T4 (1 s).

■ Factory default setting

Variable	Variable name	Value	Description
T1min	Muting input time limit value (minimum)	0.1 s	Minimum time difference between muting inputs A and B. If the time difference between muting inputs A and B is smaller than this value, a muting sequence error occurs.
T1max	Muting input time limit value (maximum)	4 s	Maximum time difference between muting inputs A and B. If the time difference between muting inputs A and B is larger than this value, a muting sequence error occurs.
T2	Muting time limit	60 s	The duration time of the Muting function. The MUTING state is cancelled if it continues for longer than this time limit.
T3	Maximum allowable muting signal interruption	0.1 s	Maximum duration of a signal interruption allowed in muting inputs A and B.
T4	Muting end wait time	1 s	Time difference from when the F3SG-SR/PG is unblocked until the MUTING state is cancelled.
T5	Exit-only muting delay time	4 s	Time difference from when the signal of Muting input A or B is turned OFF until the MUTING state is cancelled.



The MUTING state is also released when the F3SG-SR/PG enters the LOCKOUT state.

■ Basic wiring diagram

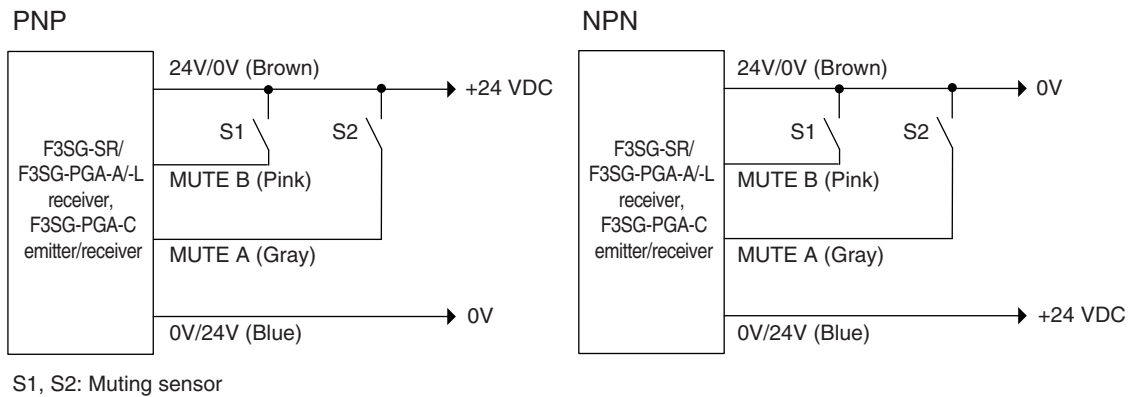

2-13-3-2. Installation Example of Exit-Only Muting Mode

This is an installation example of the Exit-Only Muting mode. When using the Exit-Only Muting mode, install the muting sensors on the hazardous side of the workpiece exit. This can be used if a workpiece has a certain length and the hazardous side of the workpiece exit has enough space around it.

1. Before a workpiece passes through

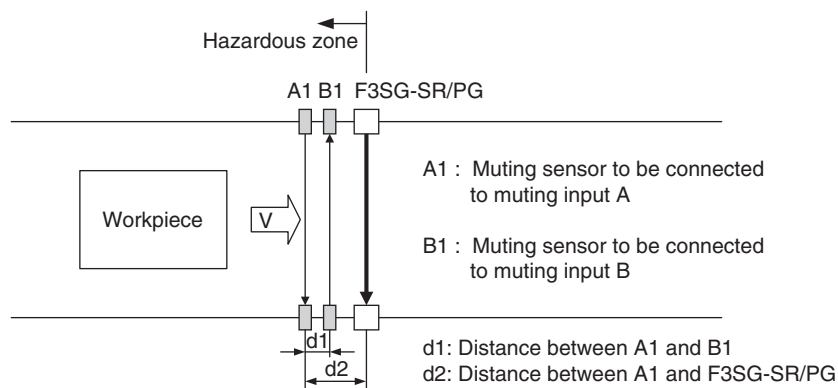

All muting sensors are turned OFF and the safety function of the F3SG-SR/PG is working.

2. MUTING started

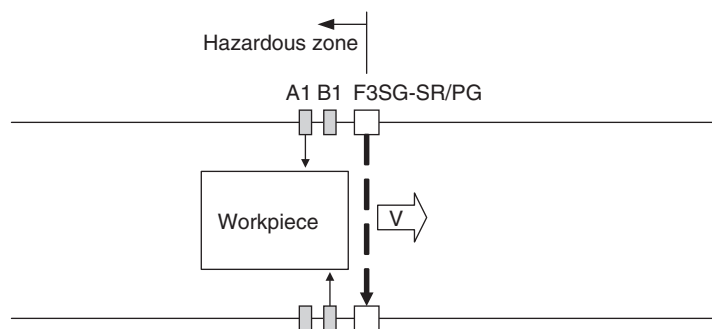

When the muting sensors A1 and B1 are turned ON in this order, and the MUTING state is enabled. In this state, the safety function of F3SG-SR/PG is disabled.

3. Muting state is maintained (Muting sensor A1: OFF)

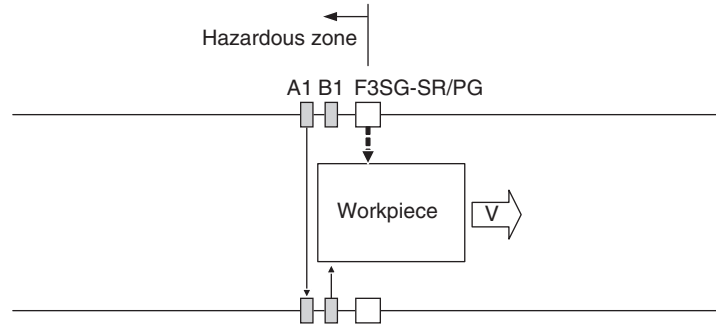

The workpiece has completely passed the muting sensor A1 and the sensor is now in the OFF state. In the Standard Muting mode, the Muting state is released here. In the Exit-Only Muting mode, the F3SG-SR/PG's safety function is disabled for the exit-only muting delay time: T5.

4. Muting state is maintained (Muting sensor B1: OFF)

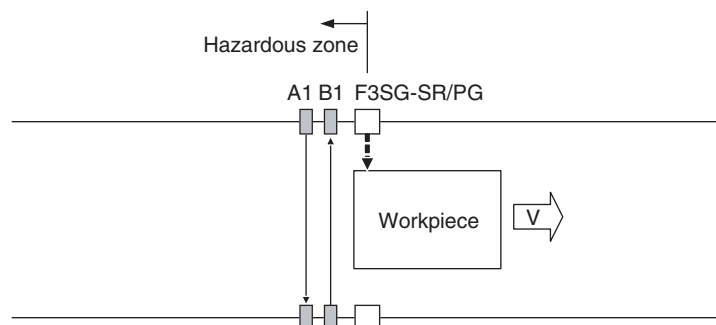

The workpiece has completely passed the muting sensor B1 and the sensor is turned OFF. The F3SG-SR/PG disables its safety function if it is within the exit-only muting delay time.

5. The workpiece passed the F3SG-SR/PG's detection zone

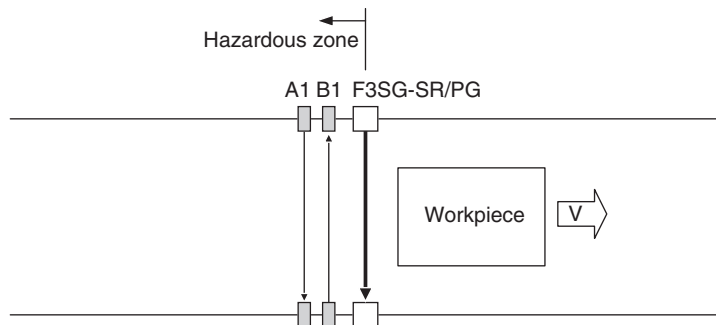

A workpiece has passed the F3SG-SR/PG's detection zone. When the muting end wait time: T4 (1 s: configurable) passes after the F3SG-SR/PG is unblocked, the MUTING state is released.

■ Installation distance

Distances between the muting sensors A1, B1, and the F3SG-SR/PG must be configured based on speed of a workpiece.

Distance d1 between the muting sensors A1 and B1 must satisfy Equations (1) and (2).

Distance d2 between the muting sensor A1 and F3SG-SR/PG must satisfy Equations (3) and (4).

Time t1 [s] to turn the muting sensors A1 and B1 in this order is:

$$t1 = d1 / V \text{ Equation (1)}$$

d1 [m] : Distance between muting sensors A1 and B1

V [m/s] : Approach speed of a workpiece

Time t1 in Equation (1) for F3SG-SR/PG to enter MUTING state is within a range shown below:

$$T1min < t1 < T1max \text{ Equation (2)}$$

T1min [s] : Muting input time limit value (minimum)

T1max [s] : Muting input time limit value (maximum)



The values of $T1_{min}$ and $T1_{max}$ can be changed by the SD Manager 3.

CHECK!

Time $t2$ [s] for a workpiece to pass the F3SG-SR/PG's detection zone after passing the muting sensor A1 is:

$$t2 = d2 / V$$

Equation (3) $d2$ [m] : Distance between muting sensor A1 and F3SG-SR/PG
 V [m/s] : Approach speed of a workpiece

Time $t2$ in Equation (3) must satisfy following condition:
 $t2 < T5$ Equation (4) $T5$: Exit-only muting delay time



The value of $T5$ can be changed by the SD Manager 3.

CHECK!

Sensors must be installed so that person's passing should not cause the MUTING state. Also, the muting sensors and F3SG-SR/PG must be installed so that MUTING state caused by a workpiece should be ended before the next workpiece arrives at the first muting sensor.

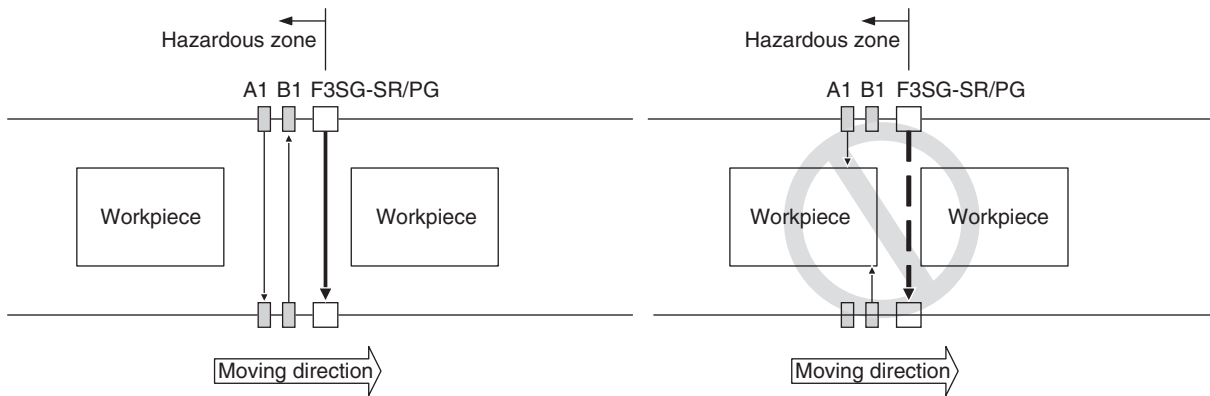

■ Timing chart

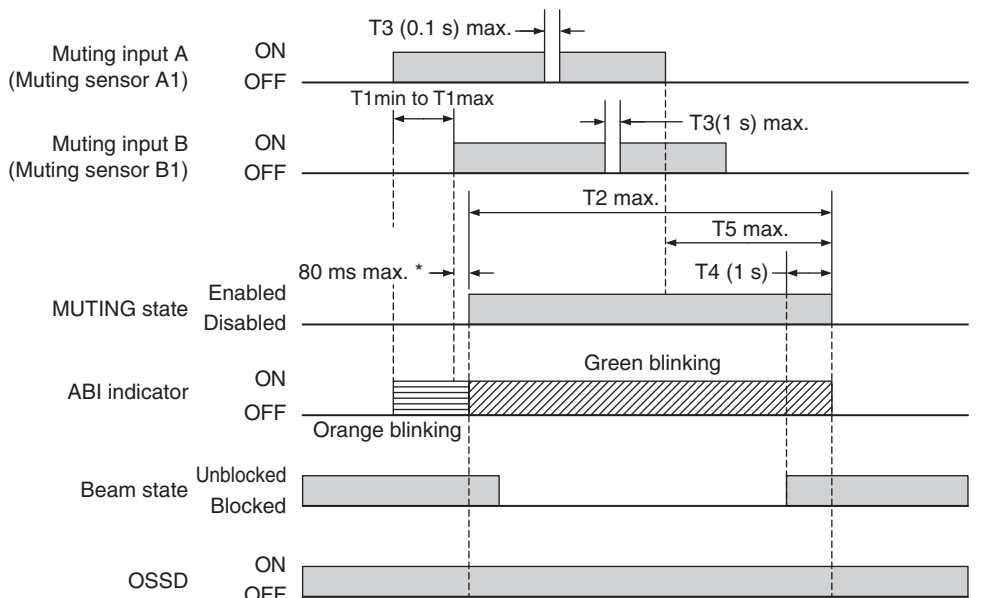

* 102 ms max. when the Intelligent Tap is connected to the F3SG-SR.

$T1_{min}$: Muting input time limit value (minimum)
 $T1_{max}$: Muting input time limit value (maximum)
 $T2$: Muting time limit
 $T3$: Maximum allowable muting signal interruption
 $T4$: Muting end wait time
 $T5$: Exit-only muting delay time

2-13-4. Position Detection Muting Mode

2-13-4-1. Overview

The MUTING state is enabled when the muting input A turns ON from the OFF state and the muting input B turns OFF from the ON state within the muting input time limit value T1max, measured by a limit switch, etc. Muting inputs must be heterogeneous redundant inputs such as the combination of NO contact and NC contact types. (When using photoelectric sensors of PNP output, use one for Light-ON operation while the other for Dark-ON.)

This mode can be used for such a case that the F3SG-SR/PG should be temporarily disabled while a worker puts objects at a loading station.



For the combination of NO and NC contacts, use the NO contact for the muting input A and the NC contact for the muting input B. For the combination of PNP-output photoelectric sensors, use Dark-ON operation for the muting input A and Light-ON operation for the muting input B.

CHECK!

■ Start conditions

If both of the following two conditions are satisfied, the MUTING state is enabled.

1. No blocking object is found in the F3SG-SR/PG's detection zone, and the safety outputs are ON.
2. The duration between when the muting input A is turned ON* from the OFF state and when the muting input B is turned OFF from the ON state* is within the range of the muting input time limit values T1max (4s: configurable) or less. Order of muting inputs A and B is irrelevant.

*PNP setting: Vs-3V to Vs, NPN setting: 0 to 3V

The MUTING state can be enabled in up to 80 ms after the condition No. 2 is satisfied.

If the condition No. 1 is satisfied but the time requirement of the condition No.2 is not, a muting error occurs, and the SEQ indicator on the receiver turns ON. However, when there is a muting error, the F3SG-SR/PG continues the normal operation with the safety function enabled.



For muting error indication, see 8-1-3-3. *Muting Sequence Error Indication*.

The Muting error state can be released by any of following conditions:

1. Correct initial muting condition continues for 0.1 s or longer. *1
2. Power cycle when the muting inputs A and B are in the OFF state.

*1 The correct initial muting condition is the state where the following two conditions are satisfied.

- Safety outputs of the F3SG-SR/PG are turned ON.
- Muting input A is turned OFF and Muting input B is turned ON.

■ End conditions

If any of the following conditions is satisfied, the MUTING state is released.

- Muting input A is in the OFF state for T3 or longer (0.1 s or longer).
- Muting input B is in the ON state for T3 or longer (0.1 s or longer).
- The duration of the MUTING state exceeds the muting time limit of T2 (60 s: Can be changed).



The MUTING state is also released when the F3SG-SR enters the LOCKOUT state.

CHECK!

■ Timing chart

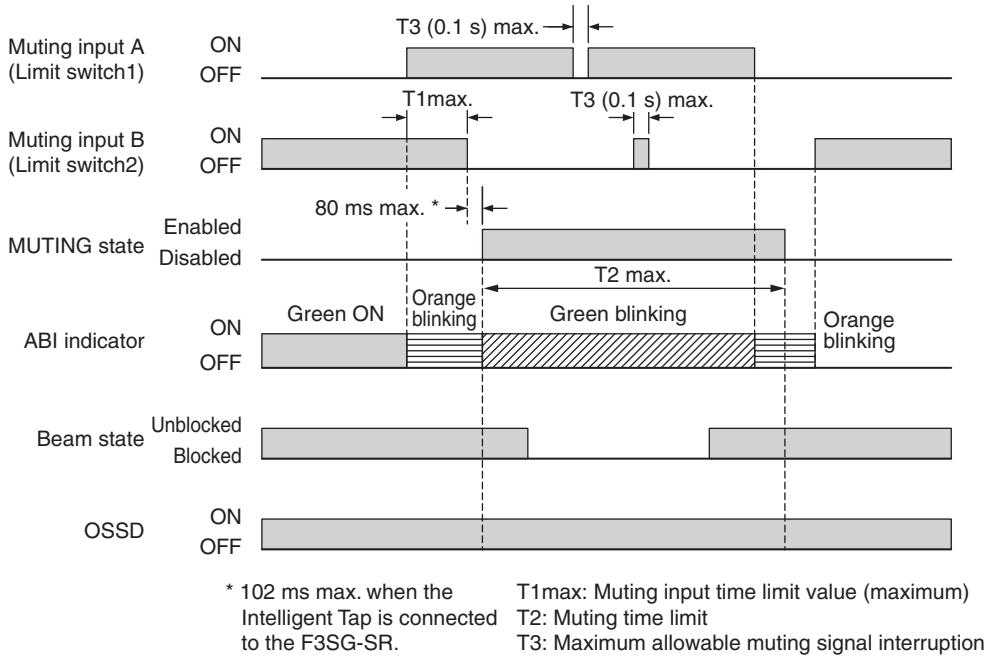

■ Factory default setting

Variable	Variable name	Value	Description
T1max	Muting input time limit value (maximum)	4 s	Maximum time difference between muting inputs A and B. If the time difference between muting inputs A and B is larger than this value, a muting error occurs.
T2	Muting time limit	60 s	The duration time of the Muting function. The MUTING state is cancelled if it continues for longer than this time limit.
T3	Maximum allowable muting signal interruption	0.1 s	Maximum duration of a signal interruption allowed in muting inputs A and B.

■ Basic wiring diagram

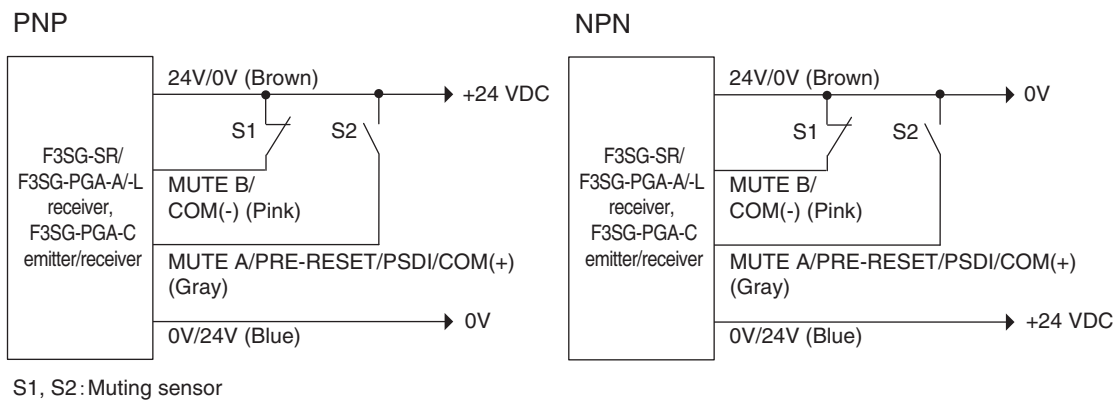

2-13-4-2. Installation Example of Position Detection Muting Mode

Shown below is an installation example of the Position Detection Muting mode.

This is an application that places a workpiece on a machine's turntable surrounded by guard fence.

When hazardous part of the machine is on the opposite side of a human body, the safety function of the F3SG-SR/PG can be disabled so that an operator should be able to place a workpiece on the turntable.

1. Hazardous part of the machine is on the same side of a human body

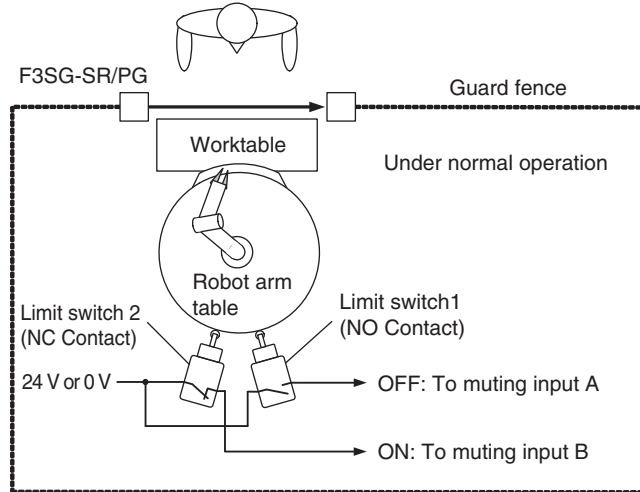

The safety functions of the F3SG-SR/PG is activated with the limit switch 1 being in OFF and the limit switch 2 being ON.

2. Hazardous part of the machine is on the opposite side of a human body

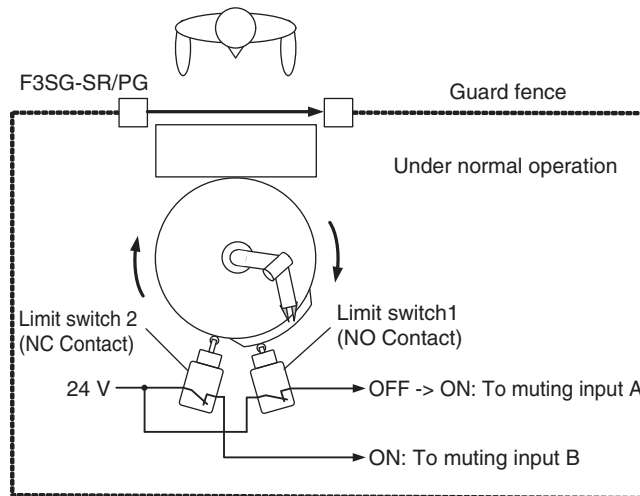

Rotation of a robot arm sets the muting input A from OFF to ON. The safety function of the F3SG-SR/PG is enabled.

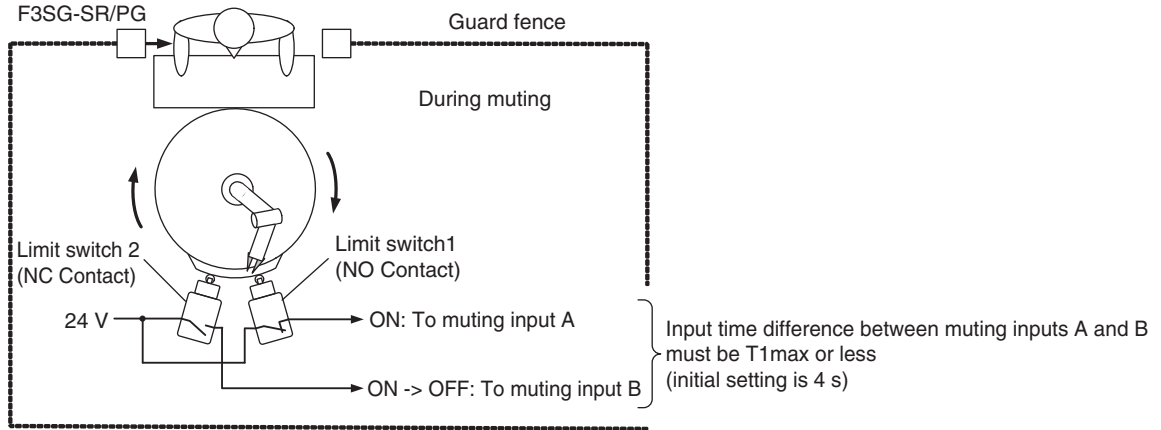

If the duration between when the muting input A is turned ON from the OFF state and when the muting input B is turned OFF from the ON state is within $T1_{max}$ [s], the safety function of the F3SG-SR/PG is disabled.

Time $t1$ [s] for the F3SG-SR/PG to enter MUTING state is within the range shown below:
 $t1 < T1_{max}$ Equation (5) $T1_{max}$ [s] : Muting input time limit value (maximum)

 The value of $T1_{max}$ can be changed by the SD Manager 3.
 CHECK!

■ Timing Chart

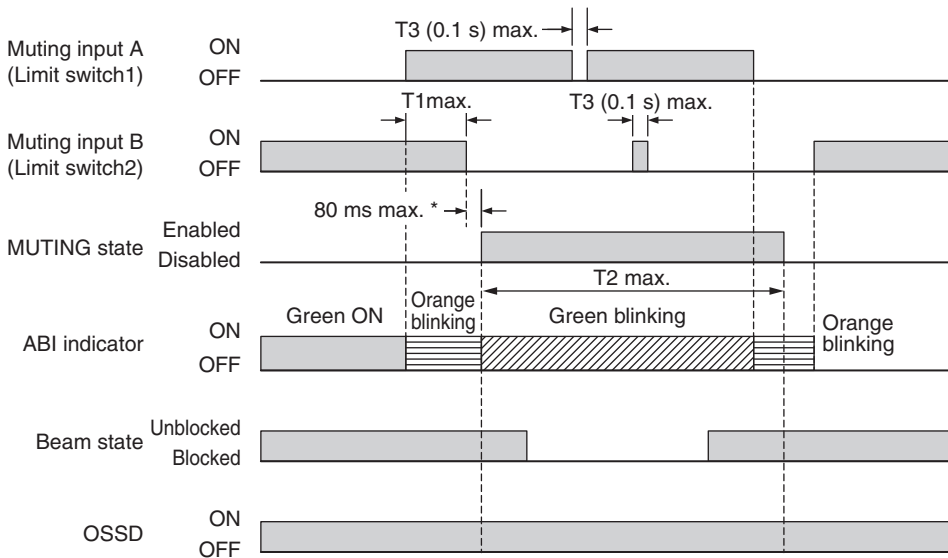

* 102 ms max. when the Intelligent Tap is connected to the F3SG-SR.
 $T1_{max}$: Muting input time limit value (maximum)
 $T2$: Muting time limit
 $T3$: Maximum allowable muting signal interruption

2-13-5. Dynamic Muting

The Dynamic Muting function can configure a new muting zone while the MUTING state is enabled, based on a result measuring a workpiece height for a certain period of time.

This materializes the safer Muting function with a limited muting zone adjusted according to a workpiece height.

■ Usage example

This function cannot be used for an application in which a workpiece height gets larger after measuring the zone as shown below.

Applicable Example		NOT Applicable Example	
Application Examples	Position after Zone Measurement	Application Examples	Position after Zone Measurement

■ Zone measurement start condition

After the muting start condition is satisfied and the full detection zone is muted, blocking a part of the F3SG-SR/PG causes the Zone Measurement to start.

■ Zone measurement

The Zone Measurement monitors the highest and lowest parts of a passing workpiece during the dynamic muting measurement time T_{dyn} (3 s: Can be changed). (Void spaces in workpiece(s) are ignored.)

■ Zone determination

A zone enclosed by the highest and the lowest parts of the workpiece is set as a new muting zone. Configuring a dynamic muting allowable beam allows the muting zone to be expanded by the number of allowable beams. Configuring a dynamic muting allowable beam prevents unintended line stop due to swing of a workpiece, etc. (The factory default setting of the dynamic muting allowable beam is 1.)

■ Dynamic muting allowable beam

The dynamic muting allowable beam allows the muting zone measured by the Zone Measurement to be expanded by the number of additional beam(s) specified as allowable beam.

■ Timing chart

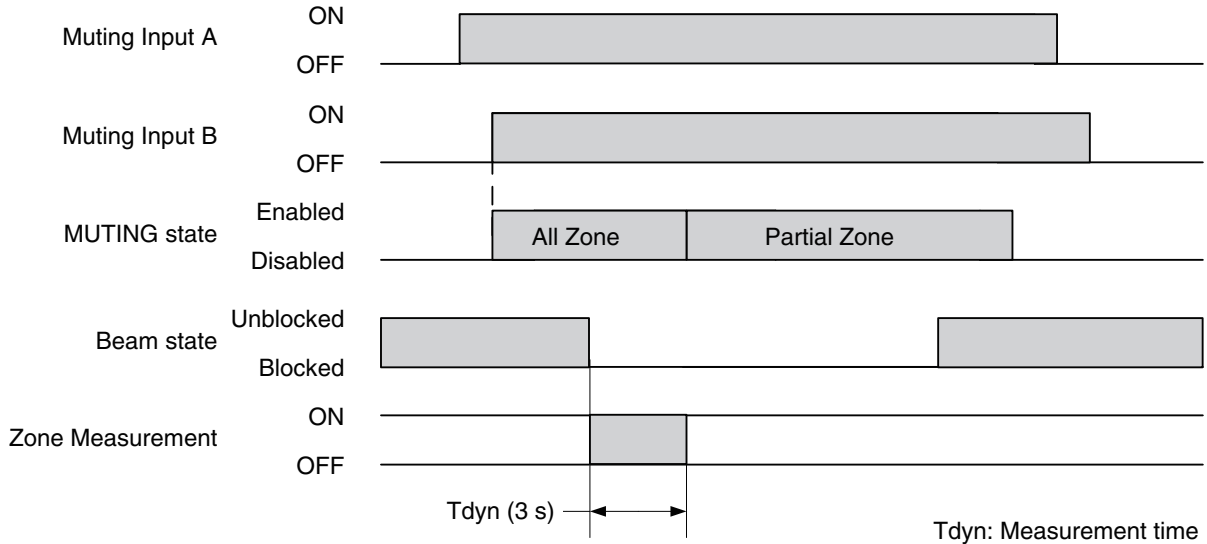

2-13-6. Factory Default Setting

The muting mode is set to Standard Muting Mode and the Dynamic Muting to Disable.

2-13-7. Setting with Intelligent Tap

If the Pre-Reset function is enabled by the DIP Switch, the Muting function is disabled. Otherwise the Muting function is always being enabled.

Refer to Chapter 3 Setting with Intelligent Tap for more information on setting this function by the Intelligent Tap.

2-13-8. Setting with SD Manager 3

The user can make changes to the settings of this function by the SD Manager 3.

Function	Initial value	Configurable value or numerical range
Muting function *	Enable	Enable/Disable
Muting mode	Standard muting mode	Standard Muting (Installation Example1) / Standard Muting (Installation Example2) Exit-only muting mode/Position detection muting mode
Setting by	Manual	Manual/Teach-in
Statistics data recording	Enable	Enable/Disable

*Setting parameters of the following functions is saved according to the states where the Muting function is enabled and disabled with the SD Manager 3, respectively. After changing the Muting function from Enable to Disable or from Disable to Enable, also check the settings of these functions again.

Affected functions: External Device Monitoring (EDM), Start Interlock, Restart Interlock, Auxiliary Output

Refer to 2-27-6. Muting Statistics Information for more information.

Standard Muting mode

Function		Initial value	Configurable value or numerical range
Muting zone	Bottom beam	All beams	any beam in 1-beam increments
	Top beam		
T1 _{min} : Muting input time limit value (minimum)		0.1 s	0.1 to 3.9 s in 0.1-s increments
T1 _{max} : Muting input time limit value (maximum)		4 s	0.2 to 60 s in 0.1-s increments, or infinite
T2: Muting time limit		60 s	1 to 600 s in 1-s increments, or infinite
T3: Maximum allowable muting signal interruption		0.1 s	0.1 to 20 s in 0.1-s increments

Exit-Only Muting mode

Function		Initial value	Configurable value or numerical range
Muting zone	Bottom beam	All beams	any beam in 1-beam increments
	Top beam		
T1 _{min} : Muting input time limit value (minimum)		0.1 s	0.1 to 3.9 s in 0.1-s increments
T1 _{max} : Muting input time limit value (maximum)		4 s	0.2 to 4 s in 0.1-s increments, or infinite
T2: Muting time limit		60 s	1 to 600 s in 1-s increments, or infinite
T3: Maximum allowable muting signal interruption		0.1 s	0.1 to 4 s in 0.1-s increments
T4: Muting end wait time		1 s	0.1 to 20 s in 0.1-s increments
T5: Exit-only muting delay time		4 s	4 to 20 s in 0.1-s increments

Position Detection Muting mode

Function		Initial value	Configurable value or numerical range
Muting zone	Bottom beam	All beams	any beam in 1-beam increments
	Top beam		
T1 _{max} : Muting input time limit value(maximum)		4 s	0.2 to 60 s in 0.1-s increments, or infinite
T2: Muting time limit		60 s	1 to 600 s in 1-s increments, or infinite
T3: Maximum allowable muting signal interruption		0.1 s	0.1 to 4 s in 0.1-s increments

Dynamic Muting

Function	Initial value	Configurable value or numerical range
Dynamic muting	Disable	Enable/Disable
Dynamic muting measurement time	3 s	1 to 25 s in 0.1-s increments
Number of dynamic muting allowable beams	1	0 to 5 in 1-beam increments

 It is recommended that the Position 2 of the DIP Switch be set at OFF (DIP Switch Disabled).
CHECK!

 Setting the muting time limit to infinite may cause a failure of the muting sensors to go undetected, resulting in the F3SG-SR in an unintended MUTING state. Conduct risk assessment analysis thoroughly before enabling this setting.
CHECK!

 Setting the muting input time limit value (maximum) to infinite may cause a failure of the muting sensors to go undetected, resulting in a failure of disabling the MUTING state. Conduct risk assessment analysis thoroughly before enabling this setting.
CHECK!

 Dynamic Muting can be used in conjunction with any of Standard, Exit-Only and Position Detection Muting modes.
CHECK!

 Refer to 4-3-4-3. *Muting/Override* for more information on setting this function by the SD Manager 3.

2-14. Override

⚠ WARNING

The Muting and Override functions disable the safety functions of the device. Especially setting the Muting Time Limit parameter to infinite may cause the safety functions to be disabled for a long time. Install the F3SG-SR/PG, muting sensor and physical barrier and configure time settings for Muting and Override so that an operator should not enter hazardous zone when the Muting and Override are active.



Muting lamps that indicate the state of the Muting and Override functions must be installed where they are clearly visible to workers from all the operating positions.



Install the switch to activate the Override function in a location that provides a clear view of the entire hazardous zone and where it cannot be activated from within the hazardous zone. Make sure that nobody is in the hazardous zone before activating the Override function.



Make sure to connect an override cancel switch to the RESET line when using the Override function. Otherwise, the OVERRIDE state may not be released by the override cancel switch, resulting in serious injury.



If a meeting error occurred while a workpiece blocks F3SG, you can use either of the following ways to remove the workpiece:



- 1) manually (with additional safety measures), or
 - 2) Override function (override under normal operation or on startup)
- You must use either of the above ways. You **MUST NOT** use both ways.

Using both ways may activate the Override function at an unintended timing for a worker.

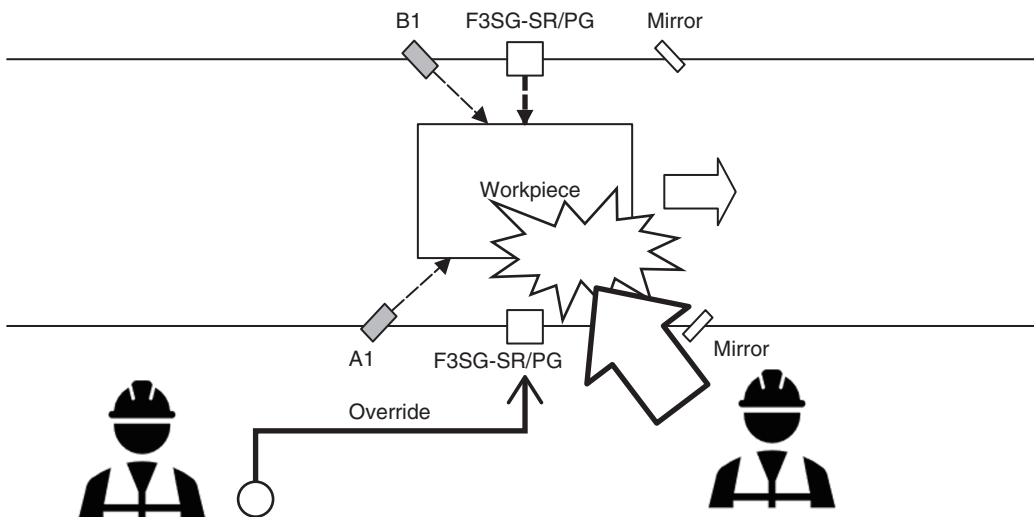

F3SG-SRA	✓	F3SG-PGA-A	✓	F3SG-PGA-C	✓
F3SG-SRB	✓	F3SG-PGA-L	✓		

2-14-1. Overview

The Override function turns the safety outputs ON when the muting start condition is not satisfied. If a workpiece stops while passing through the F3SG-SR/PG, as shown below, causing a muting error, the normal state cannot be recovered unless the workpiece is removed from the muting sensors and the detection field of the F3SG-SR/PG. However, the Override function will mute the safety outputs of the

F3SG-SR/PG so that the conveyor only can be restarted to move the workpiece out of the muting sensors and detection zone.

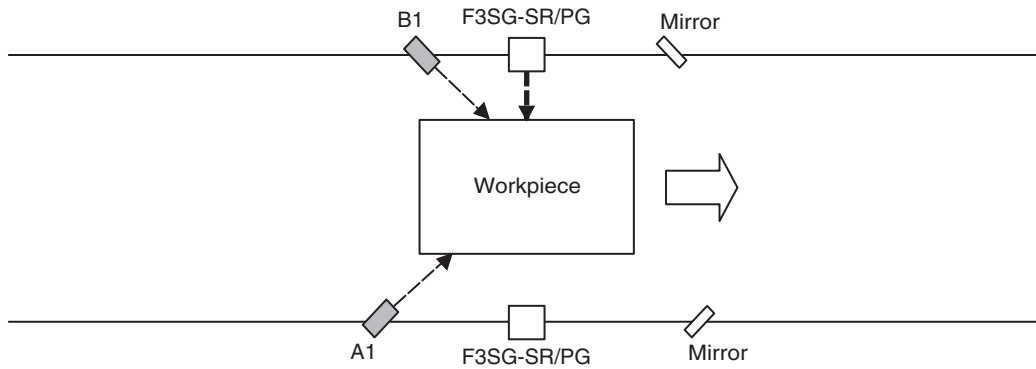

The Override function can be enabled for up to 600 s.

The Area Beam Indicator (ABI) *1 or TOP/BTM Indicator *2 blinks during the Override state.

*1 F3SG-SRA and F3SG-PGA-A/-L/-C are applicable.

*2 F3SG-SRB is applicable.

2-14-2. Override at Normal Operation

You can enable the Override function under the normal operation.

■ Override start conditions under normal operation

If all of the following conditions are satisfied, the OVERRIDE state is enabled.



CHECK!

The F3SG-SR does not enter the OVERRIDE state when the sensor is in LOCKOUT state.

Under standard muting mode

1. Either muting input A or B detects a workpiece. (One or more muting sensors are turned ON by a workpiece)
2. The F3SG-SR/PG is blocked and the safety outputs are in the OFF state.
3. An input signal of a special sequence is entered three times to the RESET line when the conditions No. 1 and 2 above are satisfied. The signal must be entered within a range from 0.1 s to the override input time limit T1 (1 s)(can be changed). (See the timing chart below.)

Under position detection muting mode

1. Either muting input A or B detects a mutable position. (Either muting input A is ON or muting input B is OFF)
2. The F3SG-SR/PG is blocked and the output is OFF.
3. Under the state of 1 and 2, provide a special sequence to the reset input three (3) times. The signal must be entered within a range from 0.1 s to the override input time limit T1 (1 s)(can be changed). (See the timing chart below.)

Under exit-only muting mode

1. Muting sequence error occurred
2. The F3SG-SR/PG is blocked and the output is OFF.
3. Under the state of 1 and 2, a special sequence is entered to the reset input three (3) times. The signal must be entered within a range from 0.1 s to the override input time limit T1 (1 s)(can be changed). (See the timing chart below.)

■ Override end conditions under normal operation

When any of the following conditions is satisfied, the OVERRIDE state is released.



CHECK!

The OVERRIDE state can be also released when the F3SG-SR enters the LOCKOUT state.

Under standard muting mode

1. A period of 600 s (configurable) passes in the OVERRIDE state
2. All muting inputs are turned OFF.
3. The following signal to cancel the OVERRIDE state is entered:
 - When the external device monitoring function is enabled, the RESET line is turned ON. (PNP: Connected to Vs-3 V~Vs; NPN: Connected to 0 V~3 V)
 - When the external device monitoring function is disabled, the RESET line is turned OFF.

Under position detection muting mode

1. A period of 600 s (configurable) passes in the OVERRIDE state
2. When muting input A is OFF and muting input B is ON
3. The following signal to cancel the OVERRIDE state is entered:
 - When the external device monitoring function is enabled, the RESET line is turned ON. (PNP: Connected to Vs-3 V~Vs; NPN: Connected to 0 V~3 V)
 - When the external device monitoring function is disabled, the RESET line is turned OFF.

Under exit-only muting mode

1. A period of 600 s (configurable) passes in the OVERRIDE state
2. When F3SG-SR/PG is unblocked
3. The following signal to cancel the OVERRIDE state is entered:
 - When the external device monitoring function is enabled, the RESET line is turned ON. (PNP: Connected to Vs-3 V~Vs; NPN: Connected to 0 V~3 V)
 - When the external device monitoring function is disabled, the RESET line is turned OFF.

■ Timing chart (When External Device Monitoring (EDM) is disabled)

Under standard muting mode

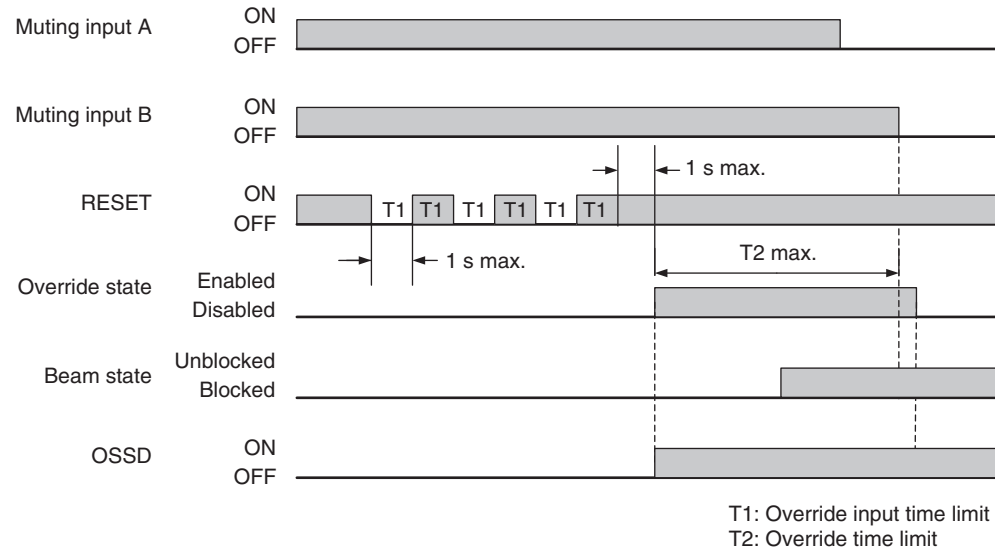

Note. In this timing chart, all muting sensors switched to OFF ends the OVERRIDE state.

Under position detection muting mode

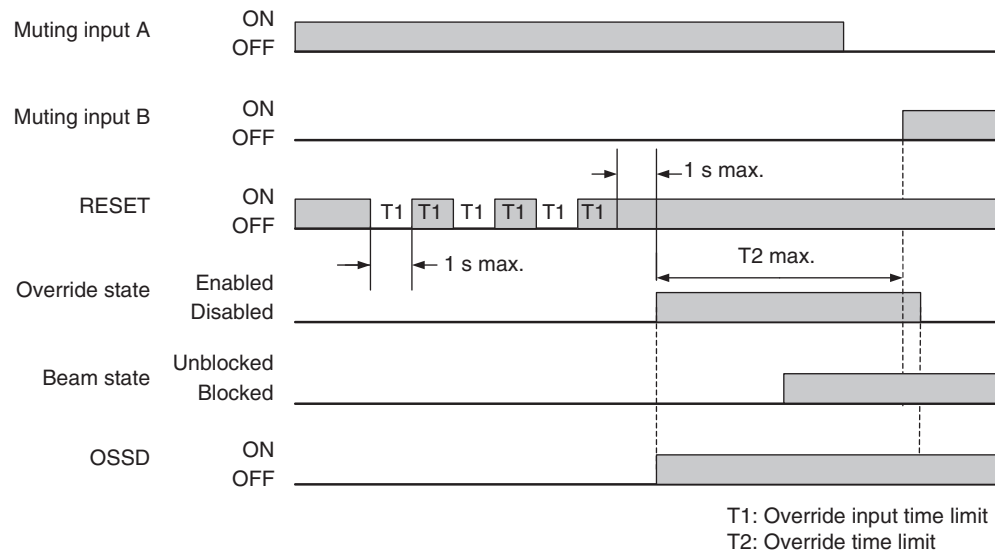

Note. In this timing chart, the OVERRIDE state ends when the muting input A is OFF and the muting input B is ON.

Under exit-only muting mode

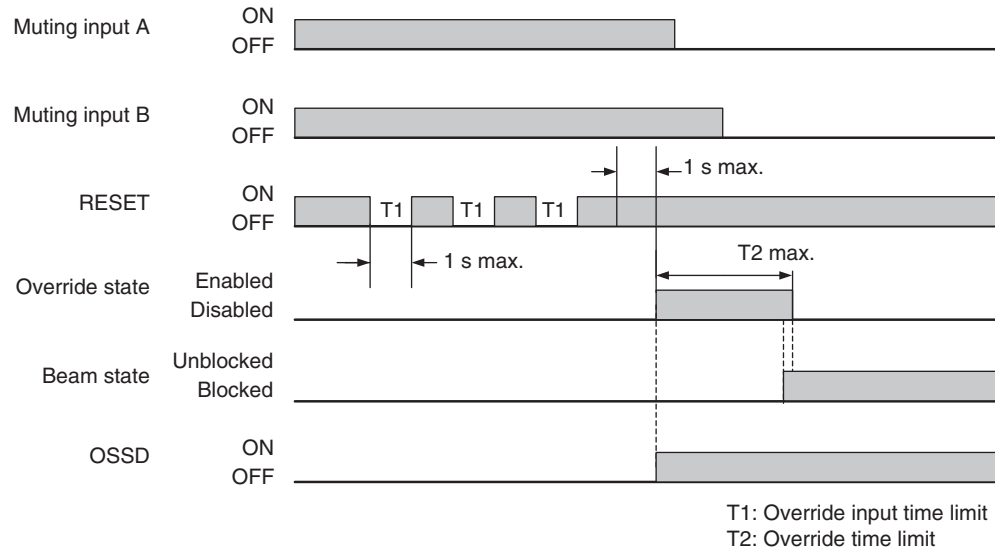

Note. In this timing chart, the OVERRIDE state ends when the F3SG-SR/PG receives light.

■ Factory default setting

Variable	Variable name	Value	Description
T1	Override input time limit	1 s	Maximum input time of override input.
T2	Override time limit	600 s	The duration time of the Override function. The OVERRIDE state is cancelled if it continues for longer than this time limit.

■ Basic wiring diagram

- External Device Monitoring used and in Manual Reset mode

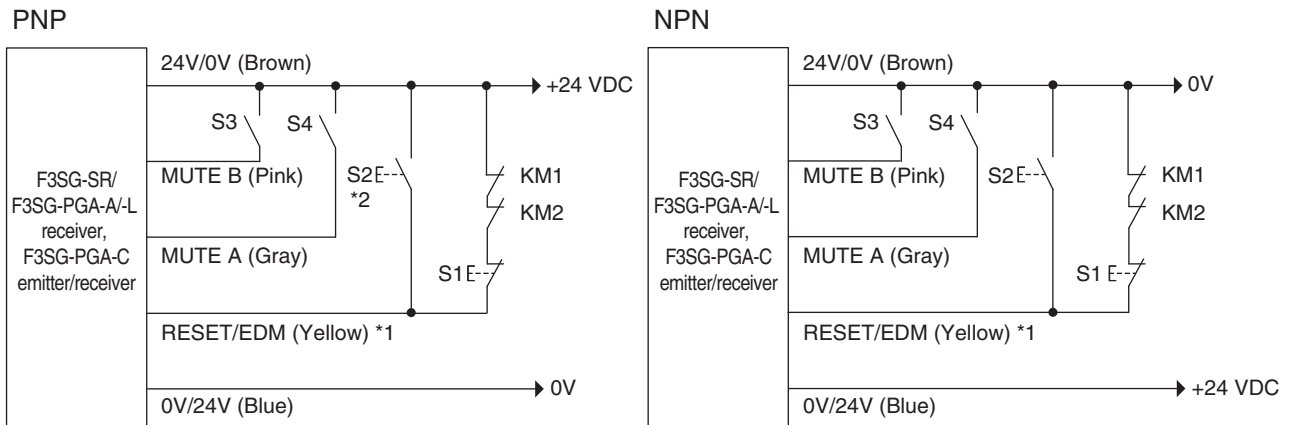

- S1: Lockout or interlock reset switch or override switch
- S2: Override cancel switch
- S3, S4: Muting sensor
- KM1, KM2: External device

*1. Also used as Override input line.

*2. Make sure to connect an override cancel switch to the RESET line when using the Override function. Otherwise the OVERRIDE state may not be released by the override cancel switch, resulting in serious injury.

- External Device Monitoring not used and in Manual Reset mode

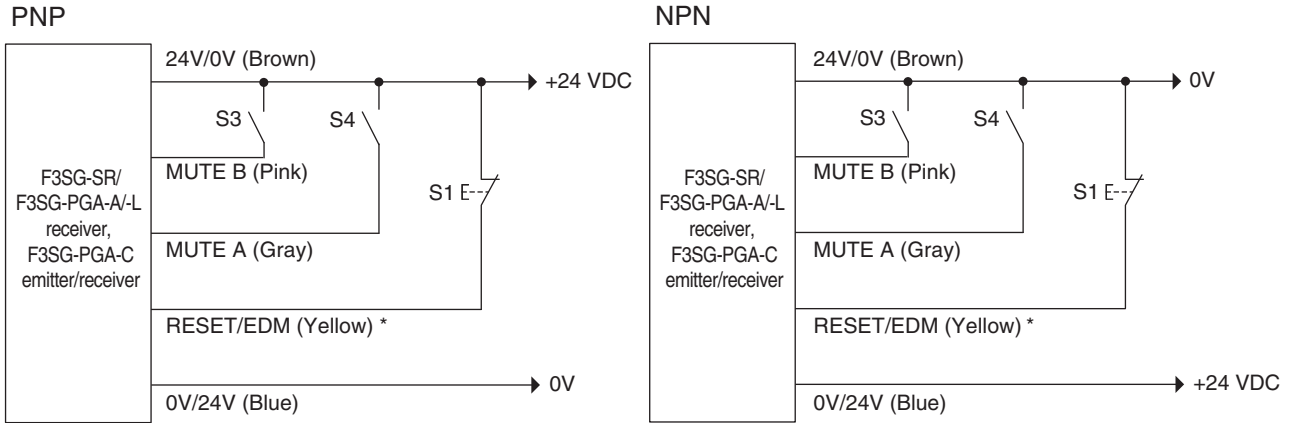

S1: Lockout/interlock reset switch or override switch or override cancel switch
 S3, S4: Muting sensor

*1. Also used as Override input line.

2-14-3. Override upon Startup

You can enable the OVERRIDE state by entering a special sequence when the power is turned on. This function is dedicated to Exit-Only Muting mode.



Under the Standard Muting mode or the Position Detection Muting mode, a workpiece can be ejected using the Override function under the normal operation as any of muting inputs always turns on even if the power is restarted while muting failed.

■ Override start conditions on startup

When all of the following conditions are satisfied, the OVERRIDE state is enabled. The OVERRIDE state can be achieved even when there is a muting error.

1. Under exit-only muting mode
2. F3SG-SR/PG is blocked
3. Under the state of 2 and 5, a special sequence is entered to the reset input three (3) times. The signal must be entered within a range from 0.1 s to the override input time limit T1 (1 s)(can be changed). (See the timing chart below.)

■ Override end condition on startup

Override is canceled when either one of the following conditions is met.

1. When 600s (can be changed) passes under the override state
2. When F3SG-SR/PG is unblocked
3. The following override cancel signal is provided
 - When the external device monitoring function is enabled, reset input is ON (PNP: Connected to Vs-3V to Vs, NPN: Connected to 0V to 3V)
 - When the external device monitoring function is disabled, reset input is OFF



The OVERRIDE state can be also released when the F3SG-SR/PG enters the LOCKOUT state.

■ Timing chart (When External Device Monitoring (EDM) is disabled)

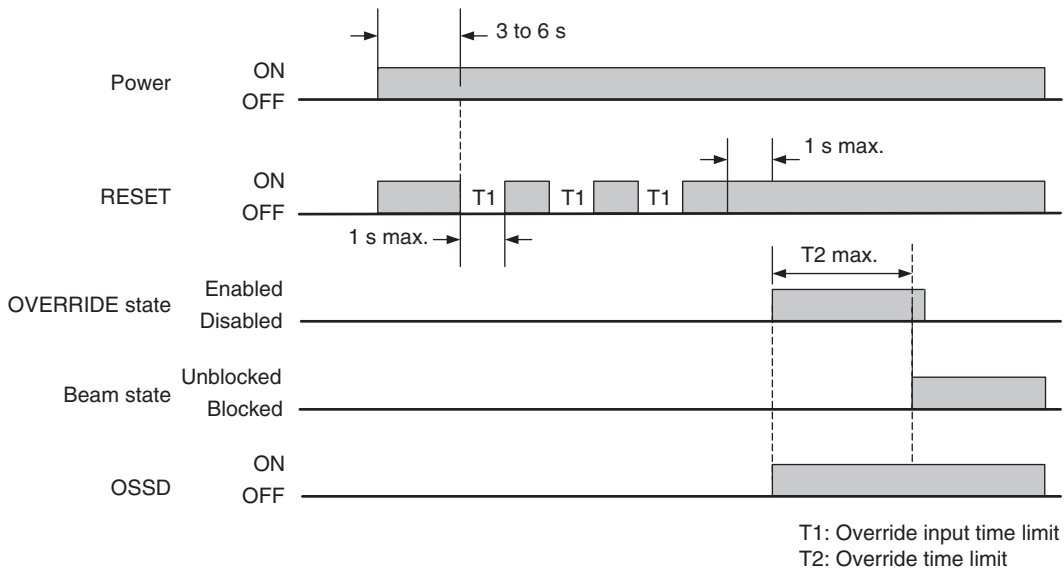

Note. In this timing chart, the OVERRIDE state ends when the F3SG-SR/PG receives light.

2-14-4. Setting with Intelligent Tap

The user cannot make any changes to this function by the DIP Switch.

2-14-5. Setting with SD Manager 3

The user can make changes to the settings of this function by the SD Manager 3.

Function	Initial value	Configurable value or numerical range
Override	Enable	Enable/Disable
Override input time limit	1 s	0.2 to 5 s in 0.1-s increments
Override time limit	600 s	1 to 600 s in 1-s increments, or infinite



It is recommended that the Position 2 of the DIP Switch be set at OFF (DIP Switch Disabled).

CHECK!



Setting the override time limit to infinite may cause a failure of disabling the OVERRIDE state when there is a failure of the override input signal. Conduct risk assessment analysis thoroughly before enabling this setting.

CHECK!



Refer to 4-3-4-3. *Muting/Override* for more information on setting this function by the SD Manager 3.

2-15. Fixed Blanking

⚠ WARNING

Install a protective structure to cover the whole blanked zone in order to prevent personnel approach to hazardous part of the machine through the blanked area.



If allowable beams are designated for Fixed Blanking, detection capability gets larger near an object that blocks beams. The safety distance calculation must be based on the increased detection capability for this function. Otherwise, the machine may not stop before a person reaches the hazardous part, resulting in serious injury.



F3SG-SRA	✓	F3SG-PGA-A		F3SG-PGA-C	
F3SG-SRB	✓	F3SG-PGA-L			

2-15-1. Overview

■ Fixed blanking function

This function disables a part of the F3SG-SR detection zone. The safety outputs stay in the ON state even if an object exists in the disabled zone.

The fixed blanking zone must include at least one zone consisting of continuous beams. Up to three fixed blanking zones (zone 1 to zone 3) can be set. Note that you cannot set all beams to the fixed blanking zone. In the primary sensor, you cannot set both of the end beams (or synchronization beams) to an identical fixed blanking zone.

■ Fixed blanking zone setting

A zone for fixed blanking zone must be configured. You can configure the zone by the Teach-In using a blocking object placed in a desired position or by designating desired beams manually. In this example shown below, the 5th and 10th beams are set as bottom and top beams respectively.



For details of the teach-in setting with Push Switch or Muting Input A., see 3-7-1. *Setting Fixed Blanking by Teach-in.*



For details of the teach-in setting with SD Manager 3, see 4-3-4-1. *Fixed Blanking.*

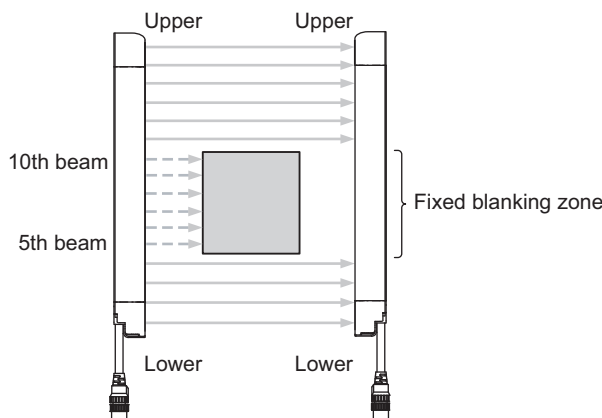

■ Fixed blanking monitoring function

For safety reasons, the F3SG-SR transitions to LOCKOUT state* if part of a fixed blanking zone is unblocked. (Factory default setting.)

In this case, power cycle or reset input enables the Fixed Blanking function again with the same setting as previous one. Turn off the power and on again or turn on the reset input while all fixed blanking zones are blocked.

When the F3SG-SR is set to Blanking Zone cancelled, the Fixed Blanking function is cancelled if part of a fixed blanking zone is unblocked.

In this case, power cycle enables the Fixed Blanking function again with the same setting as previous one.

Turn off the power and on again while all fixed blanking zones are blocked.

When quick blanking is set, if part of the zone set by the fixed blanking function is unblocked, the safety outputs are turned OFF.

In this case, if interlock is released with all the fixed blanking zones blocked, the safety outputs are turned ON.

When interlock is reset automatically, the safety outputs are turned ON at the same time as the blanking zone is blocked. When interlock is reset manually, the safety outputs are turned ON by the reset input after the blanking zone is blocked.

Setting to this monitoring function disabled disables the blanking monitoring.

* Allowable beams configured on both ends of fixed blanking zone are not monitored.

■ Allowable beam

Allowable beam represents a beam out of the target of the Fixed Blanking Monitoring. This should be configured for a fixed blanking beam that is irregularly blocked and unblocked due to oscillation of a blocking object. An allowable beam can be assigned to the beams on both ends or one end of a fixed blanking zone depending on the position of blocked beams and the number of beams in a zone to be blocked by an object (or blocked zone).

When a fixed blanking zone is configured by the Teach-in with the Push Switch or the Muting Input A, the allowable beams are configured automatically. Refer to the following descriptions for details.

For allowable beam setting with the SD Manager 3, refer to *Chapter 4 Setting with SD Manager 3*.

 Refer to 4-3-4-1. *Fixed Blanking* for more information on changing functions by SD Manager 3.

See below for an example. (The example shows the case where the settings are made by the SD Manager 3.)

In this case, 5th, 6th, and 10th beams are set as allowable beams. These beams are repeatedly blocked and unblocked due to oscillation of a blocking object. But because these beams are not the target of the monitoring, the F3SG-SR keeps the safety outputs in the ON state.

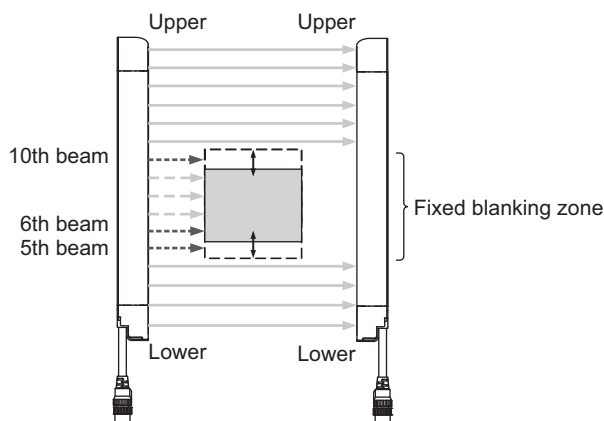

When a fixed blanking zone is configured by the Teach-in with the Push Switch or the Muting Input A, the fixed blanking zone and allowable beams are configured automatically depending on the position of blocked beams and the following conditions.

- When beams including the bottom or top beam are blocked
When beams including the bottom or top beam are blocked, allowable beams are configured as follows.

Condition	Number of blocked beams	Number of allowable beams		Zone with allowable beam configured	Figure No.
		Upper	Lower		
Beams including the bottom beam are blocked	1 or 2	1	-	Outside the upper beams of the blocked zone	Fig. 1
	3 or more	2	-	1 beam each for outside and inside the upper beams of the blocked zone	Fig. 2
Beams including the top beam are blocked	1 or 2	-	1	Outside the lower beams of the blocked zone	Fig. 3
	3 or more	-	2	1 beam each for outside and inside the lower beams of the blocked zone	Fig. 4

When beams including the lower beam are blocked:

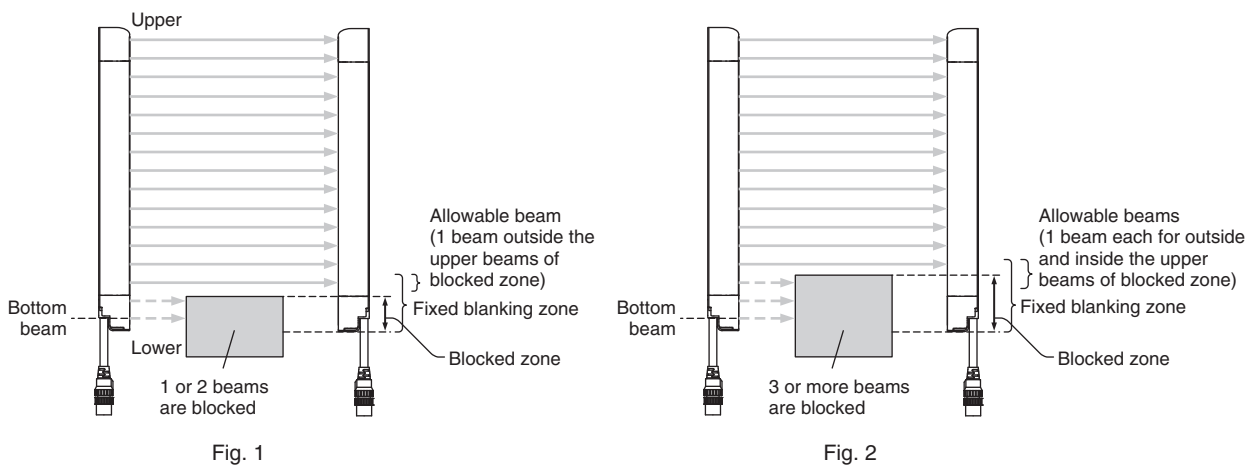

When beams including the top beam are blocked:

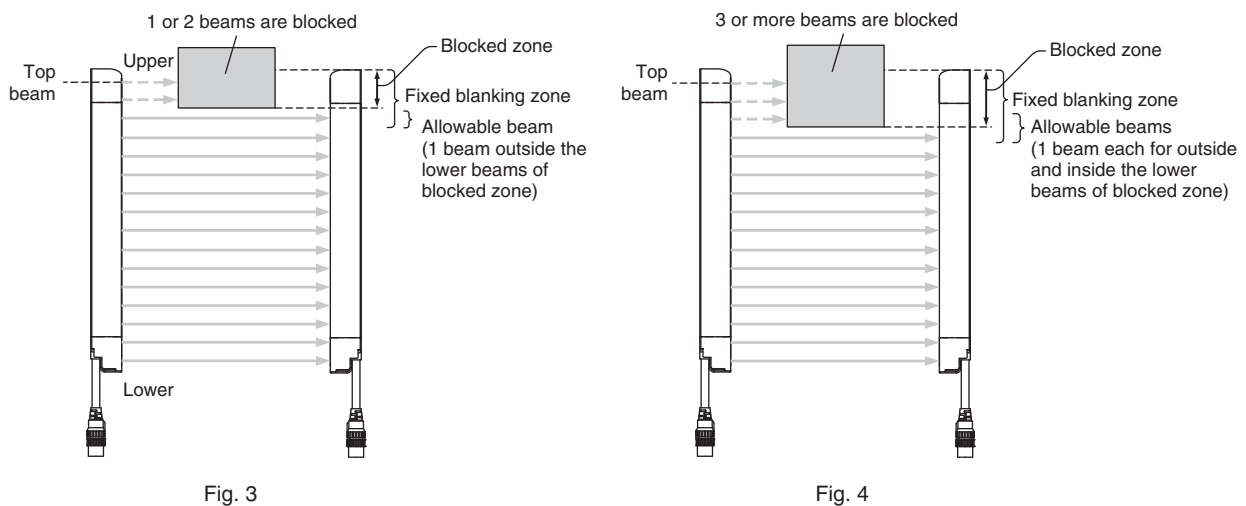

- When beams are blocked within the range from [1 beam next to bottom beam] to [1 beam next to top beam]
When beams are blocked within the range from [1 beam next to bottom beam] to [1 beam next to top beam], allowable beams are configured as follows.

Number of blocked beams	Number of allowable beams		Zone with allowable beam configured	Figure No.
	Upper	Lower		
1 or 2	1	1	Outside the blocked zone	Fig. 5
3 or more	2	2	1 beam each for outside and inside the blocked zone	Fig. 6

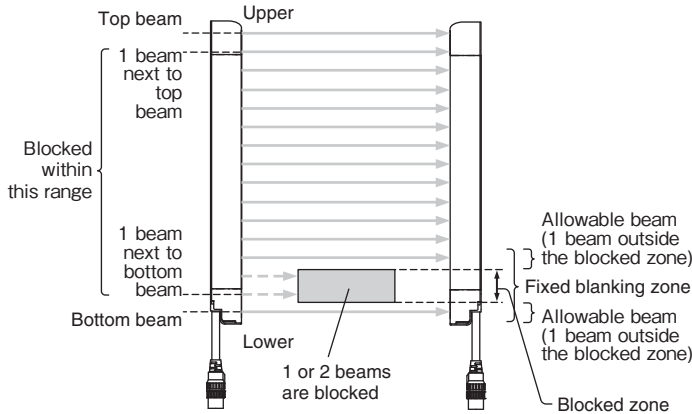

Fig. 5

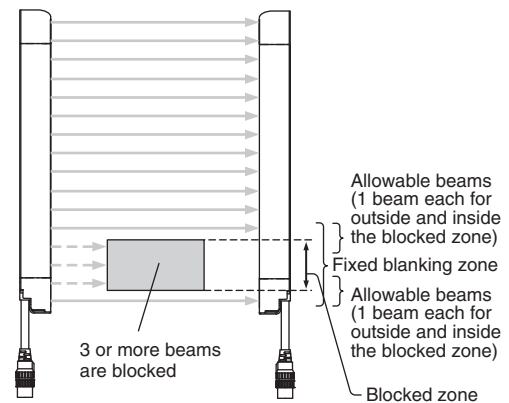

Fig. 6

The table below lists the number of allowable beams when a fixed blanking zone and allowable beams are configured with the SD Manager 3.

Number of allowable beams available for fixed blanking beams

Number of fixed blanking beams	Maximum number of allowable beams
1	Setting not possible
2	1
3	2
4	3
n	n-1

Refer to 3-7-1. *Setting Fixed Blanking by Teach-in* for more information on Teach-in with the DIP Switch.
Refer to 4-3-4-1. *Fixed Blanking* for more information on setting a fixed blanking zone with the SD Manager 3.

For detection capability on the border between the blanking zone and normal detection zone when allowable beam is configured, see next table.

Detection capability on the border between the blanking zone and normal detection zone when allowable beam is specified.

[mm]

Allowable beam on one end	F3SG-□SR□□□□□-14	F3SG-□SR□□□□□-25	F3SG-□SR□□□□□-45	F3SG-□SR□□□□□-85
Disable	14 (same as nominal)	25 (same as nominal)	45 (same as nominal)	85 (same as nominal)
1 beam	24	45	85	165
2 beams	34	85	125	245
n beams	14+(10×n)	25+(20×n)	45+(40×n)	85+(80×n)

■ LED indicator status

When the Fixed Blanking is being enabled, the CFG indicator turns on.

■ Constraint between fixed blanking zones

More than one fixed blanking zone can be configured adjacently (Figures 1 and 2). But allowable beams cannot be set adjacently (Figure 3). You cannot overlap fixed blanking zones. (Figure 4)

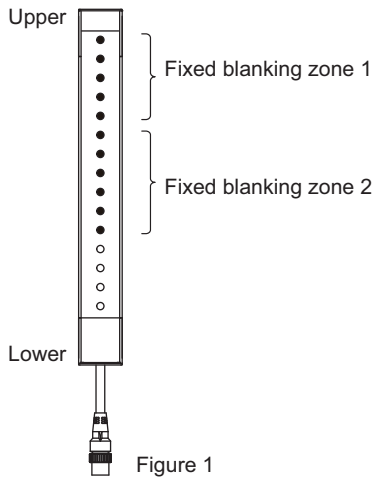

Figure 1

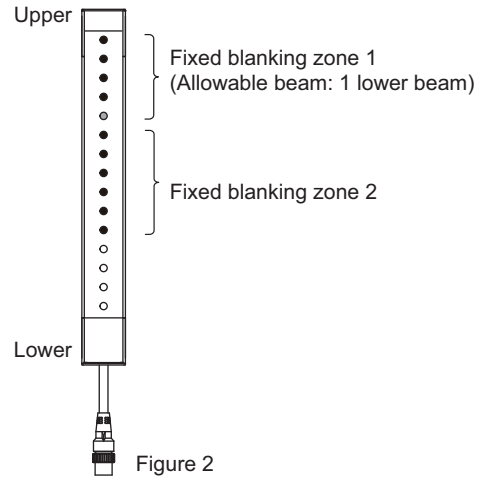

Figure 2

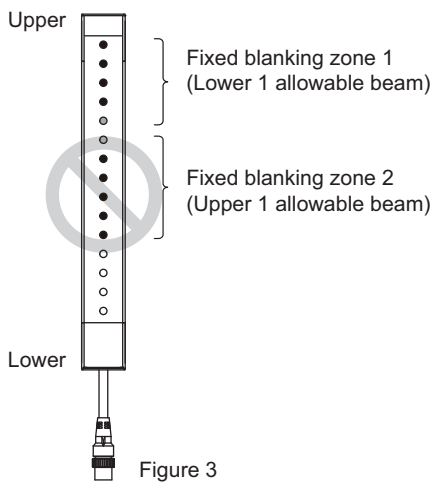

Figure 3

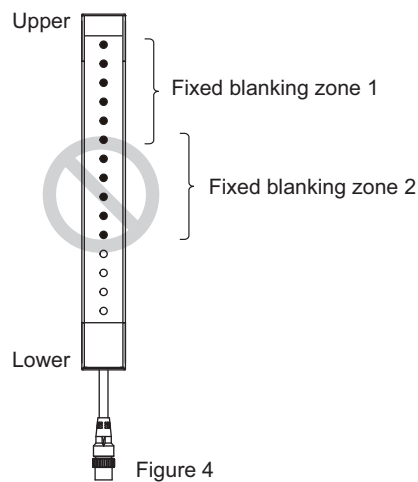



Figure 4

- Normal detecting beam
- Fixed blanking beam
- Allowable beam

■ Limitation for combination with other functions

You can use this function in combination with the Muting, Floating Blanking and Warning Zone functions at the same time with the SD Manager 3.

 Refer to 2-1. *Combination of Functions* for more information on the use in conjunction with other functions.

Settings for respective zone have limitations.

 Refer to 2-19. *Setting Zone Adjacency Conditions* for more information.

2-15-2. Factory Default Setting

Fixed Blanking is disabled.

2-15-3. Setting with Intelligent Tap

Fixed blanking can be configured using Positions 6 and 7 of the DIP Switch of the Intelligent Tap. The Fixed Blanking Monitoring function is configured as Lockout.



CHECK!

Make sure the Position 2 of the DIP Switch is set at ON (DIP Switch Enabled) to activate the settings by the DIP Switch.



Refer to *Chapter 3 Setting with Intelligent Tap* for more information on setting this function by the Intelligent Tap.

2-15-4. Setting with SD Manager 3

The user can make changes to the settings of this function by the SD Manager 3.

Setting is required for each sensor segment in case of a cascade connection.

Function		Initial value	Configurable value or numerical range
Fixed Blanking		Disable	Enable/Disable
Fixed Blanking zone	Bottom beam	1	any beam in 1-beam increments
	Top beam	1	any beam in 1-beam increments
Fixed Blanking Monitoring		Lockout	Lockout/Disable monitoring/Cancel blanking zone/Quick blanking
Number of allowable upper beams		0 beam	0 to 5 beams in 1-beam increments
Number of allowable lower beams		0 beam	0 to 5 beams (1-beam increments)



CHECK!

It is recommended that the Position 2 of the DIP Switch be set at OFF (DIP Switch Disabled).



CHECK!

Setting the Fixed Blanking Monitoring function to Disable Monitoring may create an undetectable area where a person can block the F3SG-SR without being detected, and it is not compliant with IEC 61496-2. Conduct risk assessment analysis thoroughly before enabling this setting.



Refer to *4-3-4-1. Fixed Blanking* for more information on setting this function by the SD Manager 3.

2-16. Floating Blanking

⚠ WARNING

Detection capability gets larger when the Floating Blanking function is used. When this function is used, the safety distance calculation must be based on the increased detection capability for this function. Otherwise, the machine may not stop before a person reaches to the hazardous part, resulting in serious injury.



If detection capability may get larger and a human body may pass a detection zone to reach a hazardous source, additional safety protection equipment must be installed such as a safety fence.



F3SG-SRA	✓	F3SG-PGA-A		F3SG-PGA-C	
F3SG-SRB	✓	F3SG-PGA-L			

2-16-1. Overview

■ Floating Blanking function

This function allows a specified number of beams to move freely in the detection zone of the F3SG-SR while keeping the safety outputs in the ON state.



Refer to 2-1. *Combination of Functions* for more information on the use in conjunction with other functions.

■ Floating blanking zone

All beams are configured as a floating blanking zone. If the zone overlapped with that of other function (e.g. Fixed Blanking, Warning Zone), the other function is prioritized in the overlapped zone.

■ Floating Beam

The number of beams that prevents the safety outputs to be turned OFF can be configured by setting the number of floating beams. Setting of the number of floating beams can be configured by specifying the number of beams manually or by moving a blocking object in the detection zone. For details of teach-in setting, see 3-7-2. *Setting Floating Blanking by Teach-in*.

■ Floating Blanking Monitoring function

The F3SG-SR monitors a blocking object in a floating blanking zone. (If the object is removed or gets smaller, human entry may not be detected by the F3SG-SR, resulting in serious injury.)

The F3SG-SR enters lockout when a blocking object becomes smaller, or removed. (Factory default setting) In this case, power cycle or reset input enables the Floating Blanking function again with the same setting as previous one. Turn off the power and on again or turn on the reset input while all the specified beams are blocked.

You can configure the F3SG-SR as transitioning to lockout state (factory default setting) in addition to disabling monitoring function and canceling blanking zone when a blocking object is removed.

If the monitoring function is disabled, lockout does not occur and the control output does not turn OFF when a blocking object is removed.

In case configured as Cancel blanking zone, if a blocking object gets smaller than the setting value, the Floating Blanking function is cancelled. That is, the entire detection zone of the F3SG-SR works as the normal detection zone.

In this case, power cycle enables the Floating Blanking function again with the same setting as previous one. Turn off the power and on again while all the specified beams are blocked.

If Temporarily Disable Monitoring by Wiring is configured, the monitoring function can be temporarily disabled during operation by hard wiring of the muting input A and the muting input B. For details, see below.



If Temporarily Disable Monitoring by Wiring is configured, the Muting function cannot be used.

CHECK!

Temporarily disable monitoring by external wiring

If Temporarily Disable Monitoring by Wiring is configured, the Floating Blanking Monitoring function can be temporarily disabled during operation by hard wiring of the muting input A and the muting input B of a receiver.

The Floating Blanking Monitoring function is disabled for a period of T2 by turning the muting input A from OFF to ON and the muting input B from ON to OFF within an input time difference T1 (4s) using a limit switch, etc. Inputs of the muting input A and the muting input B must be redundant inputs of different kinds such as a combination of NO contact and NC contact types.

(In case of a PNP output photoelectric sensor, use one output as Light-ON and the other as Dark-ON operation)

The user can use this function only when the F3SG-SR is used as a one segment system and the function is enabled by the SD Manager 3. The function cannot be enabled when the F3SG-SR is in the cascade connection.

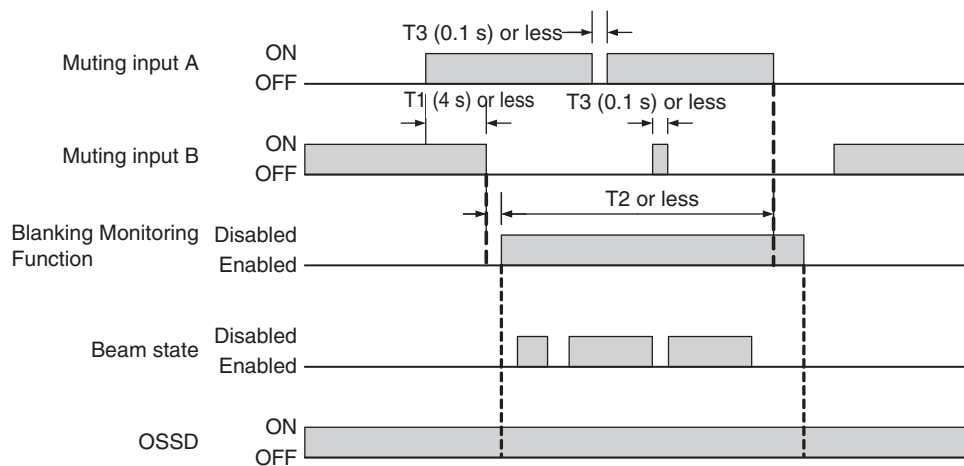

- T1: Muting input limit (fixed to 4 s)
The maximum value of an input time difference between muting input A/B. Configured as 4 s.
- T2: Monitoring Temporarily Disabled Time Limit
A time limit to disable the Floating Blanking Monitoring function. When this time period passed, the blanking monitoring function is enabled, and lockout occurs if the blanked beam is unblocked. The factory default setting is 10 s (configurable).
- T3: Maximum allowable muting signal interruption (fixed to 0.1 s)
Maximum duration of a signal interruption allowed in Muting inputs A and B. This is set at 0.1 s.

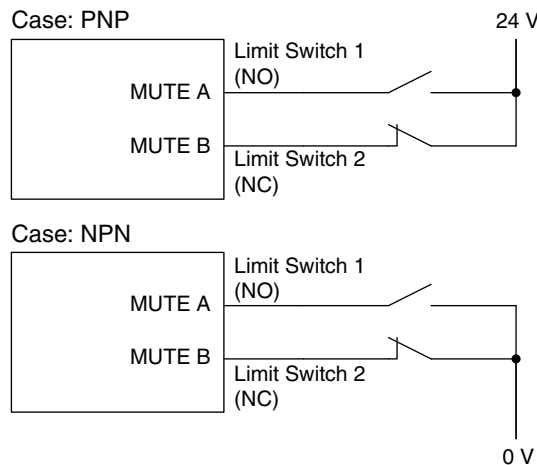

 The Muting is not enabled when the Temporarily Disable Monitoring by External Wiring is enabled.
CHECK!

■ Number of allowable beams

Number of beams in the floating blanking zone, that are not monitored by the Floating Blanking Monitoring function.

When the Floating Blanking Monitoring function is enabled and the number of blocked beams becomes less than "the number of Floating beams - the number of allowable beam(s)", the F3SG-SR enters the LOCKOUT state.

Setting Example: the F3SG-SR with 14-mm detection capability

When the number of floating beams is configured as 4 beams, the safety outputs are turned OFF if 5 or more beams are blocked. (Fig. 1)

If the monitoring function is being disabled and the number of floating beams is configured as 4 beams, the safety outputs are not turned OFF even when 4 or fewer beams are blocked or a blocking object is lost. (Fig. 2)

If the monitoring function is being enabled and the number of allowable beams is configured as 1 beam, lockout occurs when a blocking object is lost or 2 or less beams are blocked. (Fig. 3)

When also a blocking object of the size that does not turn OFF the safety outputs blocks multiple locations, the safety outputs are turned OFF. (Fig. 4)

5 or more beams are blocked

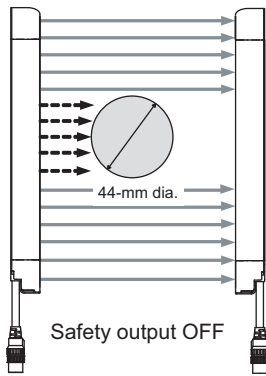

Fig. 1

4 or fewer are blocked

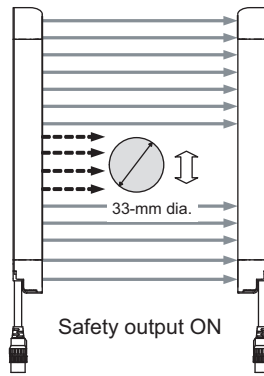

Fig. 2

2 or fewer are blocked

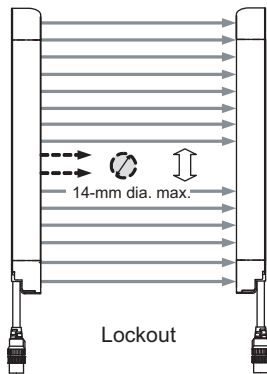

Fig. 3

More than one zone is blocked

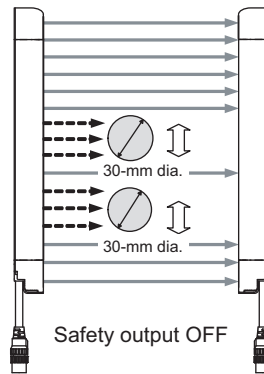

Fig. 4

■ Detection capability

Detection capability for F3SG-SR differs based on the number of floating beams as shown below.

Model	Number of floating beams configured	Detection capability	Number of blocked beams to turn safety outputs OFF
F3SG-□SR□□□□□-14	-	14 mm	1 beam
	1 beam	24 mm	2 beams
	2 beams	34 mm	3 beams
	3 beams	44 mm	4 beams
	4 beams	54 mm	5 beams
	n beams	$14+(10 \times n)$ mm	(n+1) beams
F3SG-□SR□□□□□-25	-	25 mm	1 beam
	1 beam	45 mm	2 beams
	2 beams	65 mm	3 beams
	3 beams	85 mm	4 beams
	4 beams	105 mm	5 beams
	n beams	$25+(20 \times n)$ mm	(n+1) beams
F3SG-□SR□□□□□-45	-	45 mm	1 beam
	1 beam	85 mm	2 beams
	2 beams	125 mm	3 beams
	3 beams	165 mm	4 beams
	4 beams	205 mm	5 beams
	n beams	$45+(40 \times n)$ mm	(n+1) beams
F3SG-□SR□□□□□-85	-	85 mm	1 beam
	1 beam	165 mm	2 beams
	2 beams	245 mm	3 beams
	3 beams	325 mm	4 beams
	4 beams	405 mm	5 beams
	n beams	$85+(80 \times n)$ mm	(n+1) beams

■ LED indicator status

When Floating Blanking is being enabled, the Blanking indicator turns on.

■ Limitation for combination with other functions

You can use this function in combination with the Muting, Fixed Blanking, and Warning Zone functions at the same time with the SD Manager 3. Settings for respective zone have limitations.

 Refer to 2-1. *Combination of Functions* for more information on the use in conjunction with other functions.

2-16-2. Factory Default Setting

The Floating Blanking is disabled.

2-16-3. Setting with Intelligent Tap

Floating blanking can be configured using Positions 6 and 7 of the DIP Switch of the Intelligent Tap. The Floating Blanking Monitoring function is configured as Lockout.



CHECK!

Make sure the Position 2 of the DIP Switch is set at ON (DIP Switch Enabled) to activate the settings by the DIP Switch.



Refer to *Chapter 3 Setting with Intelligent Tap* for more information on setting this function by the Intelligent Tap.

2-16-4. Setting with SD Manager 3

The user can make changes to the settings of this function by the SD Manager 3.

Setting is required for each sensor segment in case of a cascade connection.

Function	Initial value	Configurable value or numerical range
Floating Blanking	Disable	Enable/Disable
Floating Blanking Monitoring	Lockout	Disable monitoring/Lockout/Cancel blanking zone
Temporarily Disable Monitoring Function	Disable	Enable/Disable
Monitoring temporarily disabled time limit	10 s	1 to 200 s (1-s increments), or infinite
Number of floating beams	1	1 to 15 beams (1-beam increments)
Number of allowable beams	0	0 to 5 beams (1-beam increments)



CHECK!

It is recommended that the Position 2 of the DIP Switch be set at OFF (DIP Switch Disabled).



CHECK!

Setting the Floating Blanking Monitoring function to Disable Monitoring may create an undetectable area where a person can block the F3SG-SR without being detected, and it is not compliant with IEC 61496-2. Conduct risk assessment analysis thoroughly before enabling this setting.



Refer to 4-3-4-2. *Floating Blanking* for more information on changing functions by SD Manager 3.

2-17. Reduced Resolution

⚠ WARNING

Detection capability gets larger when the Reduced Resolution function is used. When this function is used, the safety distance calculation must be based on the increased detection capability for this function. Otherwise, the machine may not stop before a person reaches the hazardous part, resulting in serious injury.



If detection capability may get larger and a human body may pass a detection zone to reach a hazardous source, additional safety protection equipment must be installed such as a safety fence.



F3SG-SRA	✓	F3SG-PGA-A		F3SG-PGA-C	
F3SG-SRB	✓	F3SG-PGA-L			

2-17-1. Overview

The Reduced Resolution function prevents the safety outputs to turn off by an object moving in a detection zone. With this function, an object with a size of 1 to 3 beams can be ignored by changing a detection capability size. Unless the number of continuously blocked beams exceeds the setting (1 to 3 beams), the total number of blocked beams has no limit. The response time remains the same even when the detection capability is changed.

The difference from the Floating Blanking is that the Reduced Resolution keeps the safety outputs ON even when an object is present discontinuously.

 Refer to 2-1. *Combination of Functions* for more information on the use in conjunction with other functions.

Example:

- Enter of a person into the detection zone is monitored while enter of a transport dolly is allowed.

Example: When the setting is 2 beams

The F3SG-SR turn the safety outputs OFF when the number of blocked continuous beams is 3 or more. (Fig. 1)

The F3SG-SR does not turn the safety outputs OFF when the number of blocked continuous beams is 2 or less. (Fig. 2)

The F3SG-SR does not turn the safety outputs OFF when there are some combinations of continuously blocked beams in a detection zone but the number of the continuously blocked beams of each combination is 2 or less. (Fig. 3)

The F3SG-SR does not go to the LOCKOUT state and does not turn the safety outputs OFF even when an object has been removed from the detection zone. (Fig. 4)

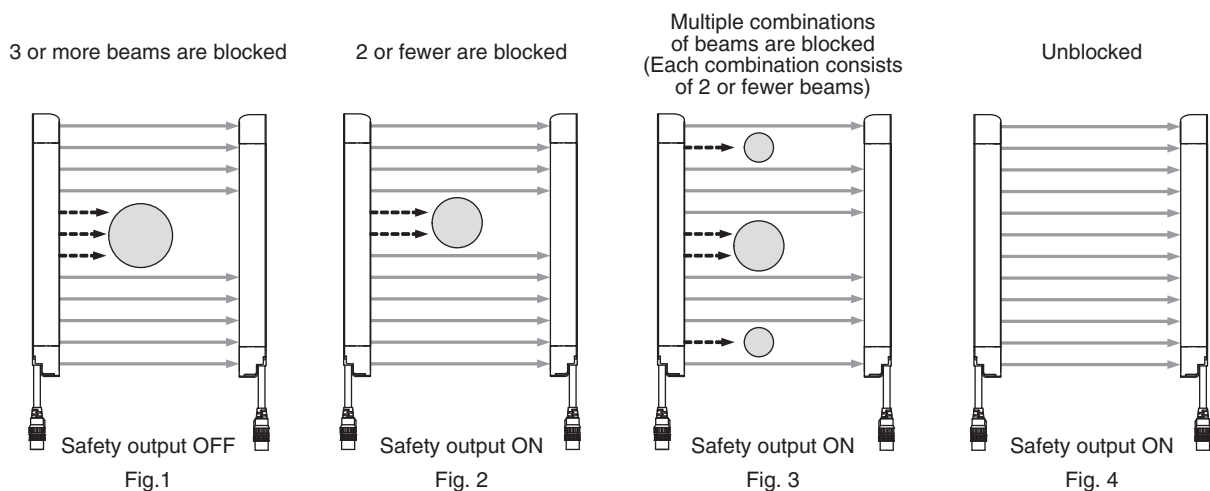

■ Detection capability

Detection capability for the F3SG-SR differs based on the number of floating beams as shown below.

Model	Number of blocked beams configured	Detection capability	Number of blocked beams to turn safety outputs OFF	Maximum diameter that does not turn off the safety outputs in the detection zone
F3SG-□SR□□□□□□-14	-	14 mm	1 beam	-
	1 beam	24 mm	2 beams	6 mm
	2 beams	34 mm	3 beams	16 mm
	3 beams	44 mm	4 beams	26 mm
F3SG-□SR□□□□□□-25	-	25 mm	1 beam	-
	1 beam	45 mm	2 beams	15 mm
	2 beams	65 mm	3 beams	35 mm
	3 beams	85 mm	4 beams	55mm
F3SG-□SR□□□□□□-45	-	45 mm	1 beam	-
	1 beam	85 mm	2 beams	35 mm
	2 beams	125 mm	3 beams	75 mm
	3 beams	165 mm	4 beams	115 mm
F3SG-□SR□□□□□□-85	-	85 mm	1 beam	-
	1 beam	165 mm	2 beams	75 mm
	2 beams	245 mm	3 beams	155 mm
	3 beams	325 mm	4 beams	235 mm

■ LED indicator status

When the reduced resolution is enabled, the CFG indicator of the F3SG-SR receiver turns ON.

 Refer to 2-1. *Combination of Functions* for more information on the use in conjunction with other functions.

2-17-2. Factory Default Setting

Reduced Resolution is disabled.

2-17-3. Setting with Intelligent Tap

The user cannot make any changes to the settings of this function by DIP Switch on the Intelligent Tap.

2-17-4. Setting with SD Manager 3

The user can make changes to the settings of this function by the SD Manager 3.

Function name	Initial value	Configurable value or numerical range
Reduced Resolution	Disable	Enable*/Disable
Number of beams	1	1 to 3 beams in 1-beam increments

*It is not possible to configure the Reduced Resolution function together with the Muting function. To enable settings of the Reduced Resolution function, disable the Muting function.

In addition, setting parameters of the following functions is saved according to the states where the Muting function is enabled and disabled, respectively. After changing the Muting function from Enable to Disable or from Disable to Enable with the SD Manager 3, also check the settings of these functions again.

Affected functions: External Device Monitoring (EDM), Start Interlock, Restart Interlock, Auxiliary Output



CHECK!

It is recommended that the Position 2 of the DIP Switch be set at OFF (DIP Switch Disabled).



Refer to 4-3-4-5. *Reduced Resolution* for more information on setting this function by the SD Manager 3.

2-18. Warning Zone

WARNING

When a warning zone is configured, you must attach labels that indicate a border between normal detection zone and warning zone. Otherwise, the machine may not stop before a person reaches to the hazardous part, resulting in serious injury.



A warning zone must not be used for safety applications. Always install your system so that a detection zone should be passed before reaching a hazardous part of the machine. If access to the hazardous part by reaching over the detection zone of a vertically mounted F3SG-SR cannot be excluded, the height of the detection zone and the safety distance shall be determined in consideration of such a risk.

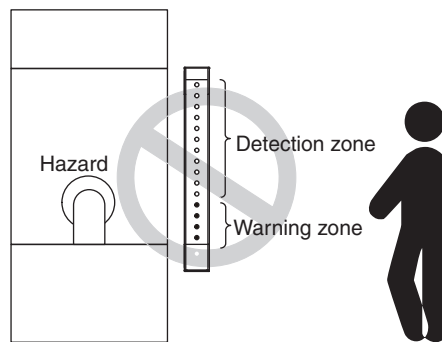

A warning zone must be configured based on a safety distance.

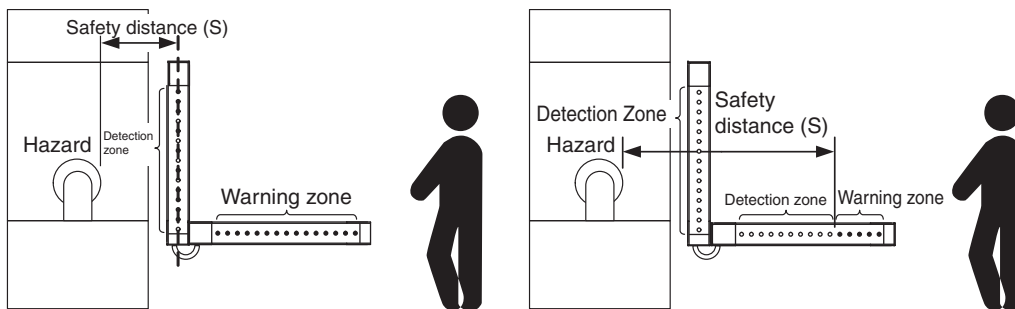

Refer to 5-1-2. *Safety Distance* for more information on safety distance calculations for orthogonal and parallel approaches.

F3SG-SRA	X	F3SG-PGA-A	-	F3SG-PGA-C	-
F3SG-SRB	X	F3SG-PGA-L	-		

2-18-1. Overview

Part of the detection zone can be set as a warning zone.

Example:

- When a person enters, indicator or buzzer should notify warning without stopping a machine.

You can specify beams to configure for warning zone. (Fig. 4 & 5)

Configuration cannot be executed for cases shown below.

- All beams are configured as a warning zone (Fig. 7).
- A warning zone is configured without including either the top end beam or bottom end beam. (Fig. 8)

When it is configured for the F3SG-SR in cascade connection to have the detection zone, it is possible for the other F3SG-SR's to have the warning zone for the all beams. (Fig. 6)

 For the application as shown in Fig. 6, make sure the primary sensor has the detection zone and the secondary sensor has the warning zone.
CHECK!

■ Operation Example

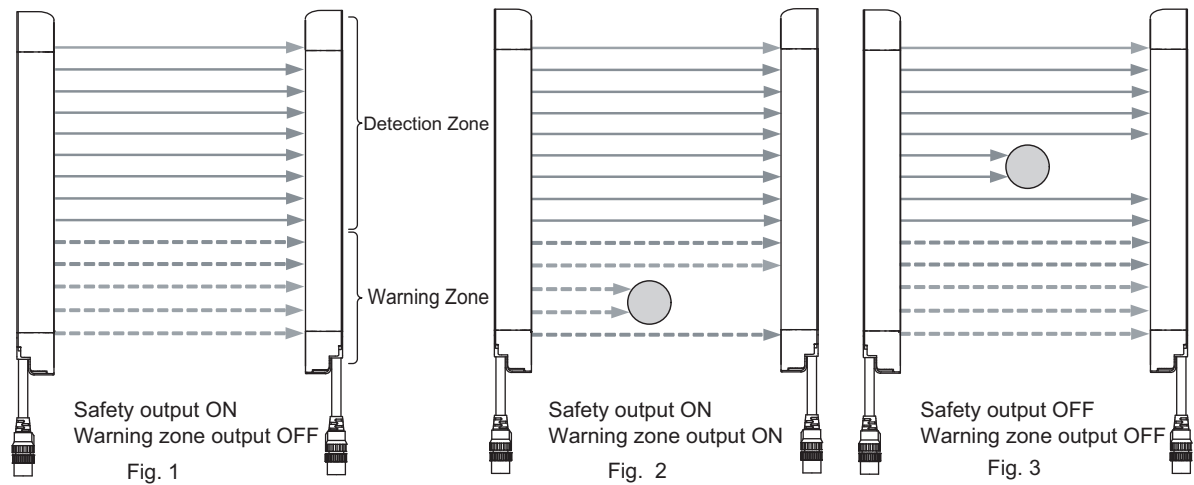

■ Timing chart

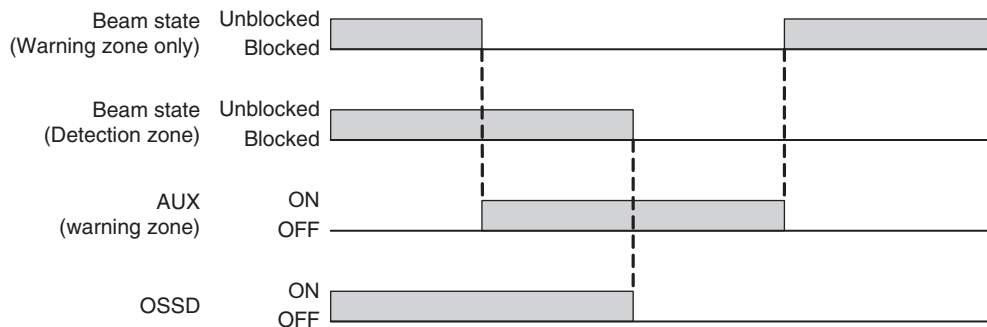

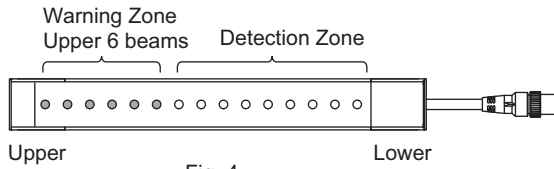

Fig. 4

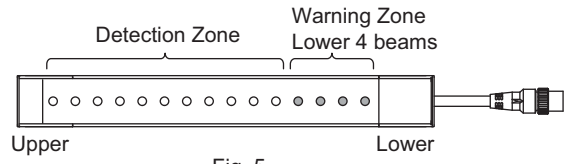

Fig. 5

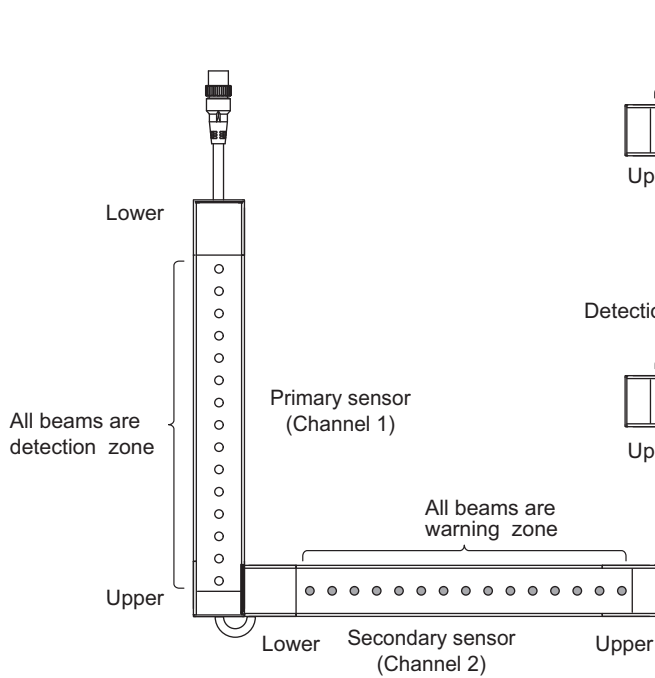

Fig. 6

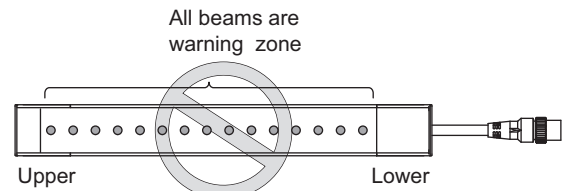

Fig. 7

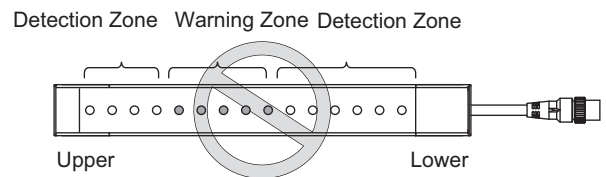
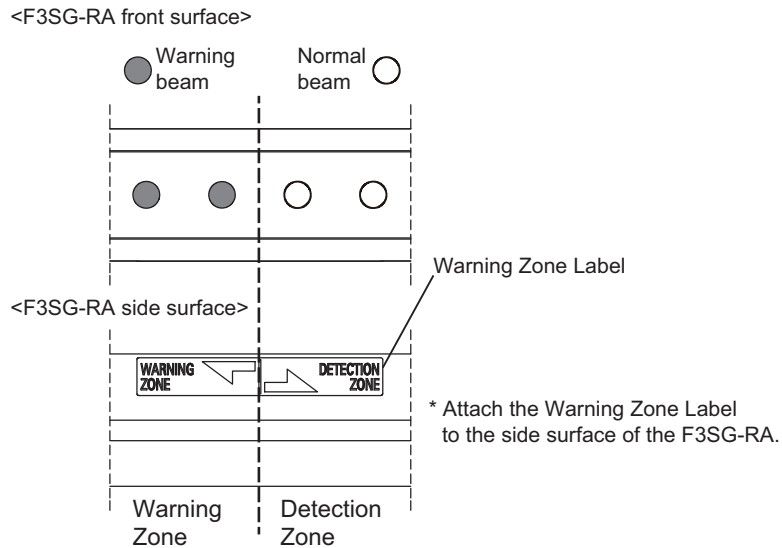

Fig. 8

When a warning zone is configured, you must attach Warning Zone Label (included) that indicate a border between normal detection zone and warning zone.



When the warning zone is enabled, the CFG indicator of the F3SG-SR receiver turns ON.

Refer to 2-1. Combination of Functions for more information on the use in conjunction with other functions.

2-18-2. Factory Default Setting

Warning Zone is disabled.

2-18-3. Setting with Intelligent Tap

The user cannot make any changes to the settings of this function by the Intelligent Tap.

2-18-4. Setting with SD Manager 3

The user can make changes to the settings of this function by the SD Manager 3.

Function	Initial value	Configurable value or numerical range
Warning Zone	Disable	Disable/Enable from upper/Enable from lower
Zone setting	None	Any beam from top beam/any beam from bottom beam
Setting by	Manual	Manual/Teach-in

If you want to output the beam state of the warning zone, set the output operation mode of the Auxiliary Output to Warning Zone Information.



It is recommended that the Position 2 of the DIP Switch be set at OFF (DIP Switch Disabled).

CHECK!



Refer to 4-3-4-6. *Warning Zone* for more information on setting this function by the SD Manager 3.

2-19. Setting Zone Adjacency Conditions

If any two functions of Muting, Fixed Blanking or Warning Zone functions of the F3SG-SR are used at the same time, the setting zones have limitations.

This section describes the limitations for following points:

1. Zone adjacent condition: If zones for multiple functions are configured adjacently
2. Zone overlap condition: If zones for multiple functions are configured as overlapped

2-19-1. Zone Adjacency Condition

The table below describes the conditions to configure setting zones for adjacent beams. Except for some conditions, setting zones for these 3 functions can be located adjacently. The user can make the setting by the SD Manager 3.

Zone adjacency condition

Function	Muting	Fixed Blanking	Warning Zone
Muting	-	Yes	Yes
Fixed Blanking	Yes	*	Yes
Warning Zone	Yes	Yes	-

Yes: Possible to configure

* For details about setting adjacent fixed blanking zones.



Refer to *Constraint between fixed blanking zones* under 2-15. *Fixed Blanking*.

2-19-2. Zone Overlap Condition

The table below describes the conditions to configure setting zones for overlapping beams. Except for combination of muting zone and fixed blanking zone (figure 1), setting zones of these 3 functions cannot be overlapped. (Figure 2)

The user can make the setting by the SD Manager 3.

Zone overlap condition

Function	Muting	Fixed Blanking	Warning Zone
Muting	-	Yes	No
Fixed Blanking	Yes	No	No
Warning Zone	No	No	-

Yes: Possible to configure

No: Not possible to configure

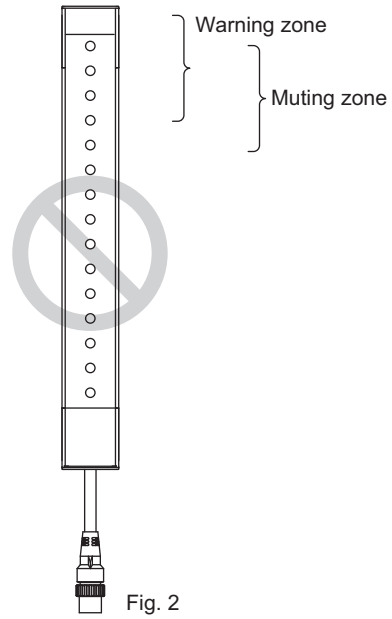
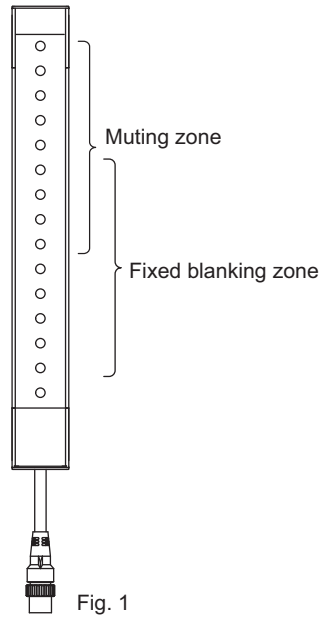

Setting zones of Muting and Floating functions can be overlapped only if each zone covers the full detection zone.

CHECK!



Even if a muting zone and a fixed blanking zone are configured as overlapped, Fixed Blanking Monitoring function is effective.

CHECK!

2-20. Operating Range Selection

F3SG-SRA	✓	F3SG-PGA-A		F3SG-PGA-C	
F3SG-SRB	✓	F3SG-PGA-L	✓		

2-20-1. Overview

The Operating Range Selection function can change the operating range by changing emission light intensity.

The following two modes in the table below are available for operating range.

Mode	F3SG-SR				F3SG-PGA-L
	Operating range *2*3				Operating range *2
	14 mm *1	25 mm *1	45 mm *1	85 mm *1	-
Short	0.3 to 3.0 m	0.3 to 7.0 m			0.5 to 20 m
Long	0.3 to 10.0 m	0.3 to 20.0 m			20 to 70 m

*1 Detection capability

*2 If the spatter protection cover (F39-HSG) is attached, the operating range of F3SG-SR and F3SG-PGA-L/A decreases by about 10%, and that of F3SG-PGA-C by about 20%.

*3 The operating range of the IP69K model is about 20% lower than that of the standard model.

Example

- To set shorter operating range to prevent the F3SG-SR or F3SG-PGA-L from affecting other photoelectric sensors
- To set shorter operating range to prevent mutual interference in a close area

LED indicator status

When the Operating Range Selection is configured as LONG Mode, the LONG indicator turns on.

Basic wiring diagram

PNP

• Long mode

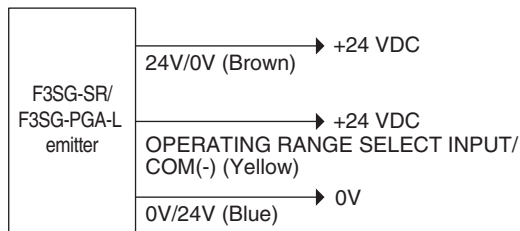

• Short mode

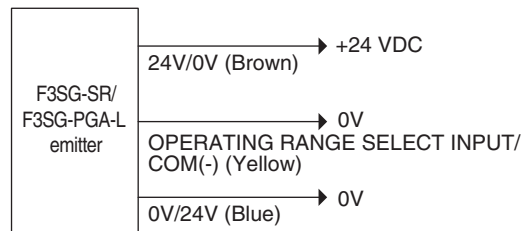

NPN

• Long mode

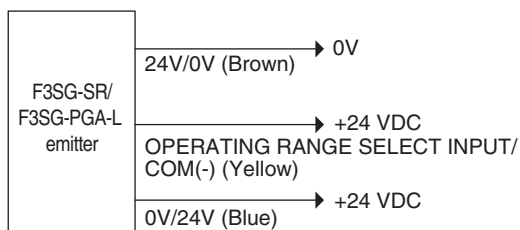

• Short mode

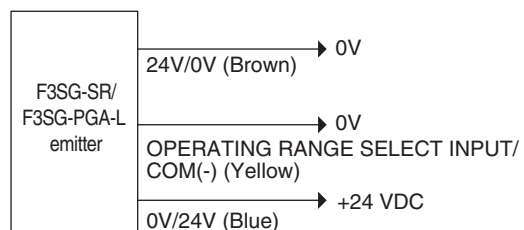

- The F3SG-SR is set to the Long Mode when the OPERATING RANGE SELECT INPUT line (yellow) is open.
- When setting to the operating range by wiring the OPERATING RANGE SELECT INPUT line, the setting is enabled at power-on. Perform the wiring before turning the power on.
- In case of F3SG-PGA-A and F3SG-PGA-C, the operating range is fixed regardless of wiring and intelligent tap setting.

2-20-2. Factory Default Setting

The Operating Range Selection is configured as Long Mode. The operating range for the long mode setting is from 0.3 to 20 m for F3SG-SR 25-mm/45-mm/85-mm detection capability model, from 0.3 m to 10 m for F3SG-SR 14-mm detection capability model, and from 20 to 70 m for F3SG-PGA-L.

2-20-3. Setting with Intelligent Tap

The user can select the mode of Operating Range Selection by the DIP Switch.



- Make sure the Position 2 of the DIP Switch is set at ON (DIP Switch Enabled) to activate the settings by the DIP Switch.
- Under the optical synchronization setting, the operating range is determined by the wiring of the operating range selection input line, regardless of the setting of the Intelligent Tap.



Refer to *Chapter 3 Setting with Intelligent Tap* for more information on setting this function by the Intelligent Tap.

2-20-4. Setting with SD Manager 3

The user can make changes to the settings of this function by the SD Manager 3.

Function name	Description	Initial value	Configurable value or numerical range
Operating Range Selection	Select the operating range.	Long mode	Short mode/Long mode



- It is recommended that the Position 2 of the DIP Switch be set at OFF (DIP Switch Disabled).
- Under the optical synchronization setting, the operating range is determined by the wiring of the operating range selection input line, regardless of the setting of the SD Manager 3.



Refer to 4-3-5-3. *Operating Range Selection* for more information on changing functions by SD Manager 3.

2-21. Response Time Adjustment

WARNING

To change the response time, calculate the safety distance based on the setting. Otherwise, the machine may not stop before a person reaches the hazardous part, resulting in serious injury.



F3SG-SRA	✓	F3SG-PGA-A	✓	F3SG-PGA-C	✓
F3SG-SRB	✓	F3SG-PGA-L	✓		

2-21-1. Overview

The Response Time Adjustment function allows the user to select the longer response time in order to reduce the chance the safety outputs are turned OFF by an accidental block of the F3SG-SR due to an environmental factor. Environmental factors include noise, smoke, dust, and bugs.

2-21-2. Factory Default Setting

The response time is configured to the normal mode.



For the response time of factory default setting, see 1-6-1. *List of Models and Response Times*

2-21-3. Setting with Intelligent Tap

The user cannot make any changes to the settings of this function by the Intelligent Tap.

2-21-4. Setting with SD Manager 3

The user can make changes to the settings of this function by the SD Manager 3.

Function	Initial value	Configurable value or numerical range
Response Time Adjustment	Normal mode	Normal mode/2 times slow/ 4 times slow/8 times slow

The ON-to-OFF response time of the Slow mode is doubled compared to the Normal mode.

Slow mode	ON to OFF response time
2 times slow	2 times slower than normal mode
4 times slow	4 times slower than normal mode
8 times slow	8 times slower than normal mode



It is recommended that the Position 2 of the DIP Switch be set at OFF (DIP Switch Disabled).

CHECK!



Refer to 4-3-5-1. *Response Time Change* for more information on changing functions by SD Manager 3.

2-22. Area Beam Indicator (ABI)

F3SG-SRA	✓	F3SG-PGA-A	✓	F3SG-PGA-C	✓
F3SG-SRB		F3SG-PGA-L	✓		

2-22-1. Overview

The unblocked/blocked state of beams, internal state of the sensor, and the state of external wiring are displayed on the Area Beam Indicator (or ABI indicators) located on the beam face according to the setting below.

 When the wired synchronization setting is applied, the ABI indicators of the emitter and receiver display synchronously. When the optical synchronization setting is applied, the ABI indicators of the emitter always holds OFF.
CHECK!

 In the Optical Synchronization, the ABI indicators are illuminated based on the table above after synchronization is established between the emitter and receiver. If synchronization is not established yet, the ABI indicators are not illuminated.
CHECK!

■ Unblocked/Blocked State

The ABI indicators located near each beam is illuminated according to the unblocked/blocked state of the beam.

The basic operation is as follows.

Beam unblocked/blocked state	ABI indicator state
Unblocked (stably unblocked or unstably unblocked) and safety outputs OFF.	OFF
Stable state and safety outputs ON	Illuminated in green
Unstable state and safety outputs ON	Illuminated in orange
Blocked	Illuminated in red

[F3SG-SRA ABI placement example]

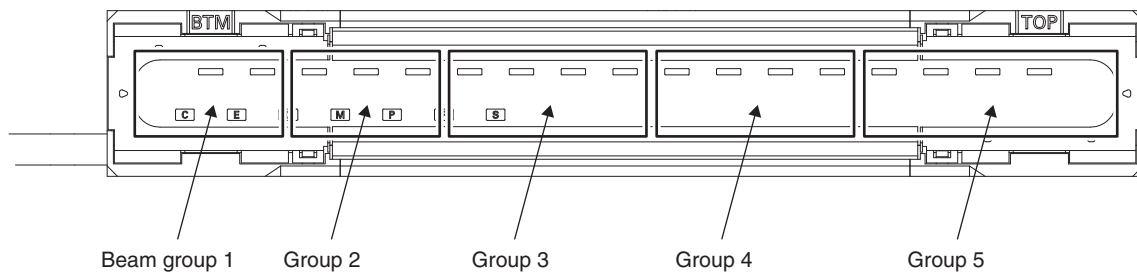

[F3SG-PG ABI placement example]

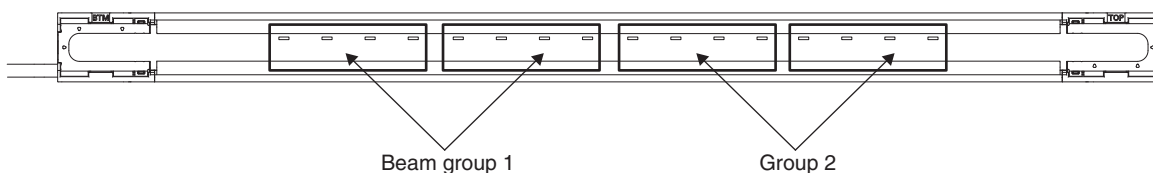

For example on the figure above, if even one of the beams in beam group 1 is blocked, the ABI indicators of that group are illuminated in red. When all the beams in that group are unblocked, the ABI indicators are turned OFF.

After the control output is turned ON, if even one of the beams in a group enters the unstable state, the the ABI indicators of that group are illuminated in orange.

[ABI indication in beam alignment]

For the installation of the F3SG-SR/PG, you can use the ABI indicators to display that beam alignment is successful.

After the F3SG-SR/PG is powered up and synchronization between the emitter and receiver is established, if stable unblocked state cannot be confirmed, the ABI indicators are illuminated as follows. However, the F3SG-SR/PG does not monitor all beams like in normal operation but monitors the unblocked/blocked state of only some beams in the group (hereinafter those beams are called monitoring beams). One or two beams are selected automatically from the group as monitoring beams.

Unblocked/blocked state of monitoring beam	ABI indicator state
Stable state	Illuminated in orange
Unstable state or blocked	Illuminated in red

When all monitoring beams reach stable state, all the ABI indicators change indication at every second like green -> orange -> green -> orange -> green, indicating that beam adjustment is completed.



This operation is executed only in the unblocked/blocked state indication configuration and during start-up. In addition, if stable state of all monitoring beams can be confirmed soon after synchronization is established, this indication is not executed. So, after installation is completed, when the F3SG-SR is powered up again in the arrangement and usage that all beams are unblocked or in the normal blocked state, the indication above is not executed.

■ Input Signal Linkage

Indication of all the ABI indicators can be operated by muting input A and muting input B. For example, by turning ON the ABI indicators using the output signal from the PLC, the ABI indicators are usable as a guide light for the operator.

Muting input A	Muting input B	ABI indicator state
0 V to 1/2 Vs	0 V to 1/2 Vs	OFF
Vs-3 V to Vs	0 V to 1/2 Vs	Illuminated in green
0 V to 1/2 Vs	Vs-3 V to Vs	Illuminated in red
Vs-3 V to Vs	Vs-3 V to Vs	Illuminated in orange

■ Output Information

F3SG-SR/PG's state can be displayed by the ABI indicators. The information assigned is equal to the information assigned to the auxiliary output.



For the details of the information assigned to the auxiliary output, refer to 2-12. *Auxiliary Output*.

2-22-2. Factory Default Setting

The factory default setting is set as unblocked/blocked state information.

2-22-3. Setting Change using Intelligent Tap

It is unable to change the setting of this function using the DIP Switch of the Intelligent Tap.

2-22-4. Setting Change using SD Manager 3

The following setting can be done using SD Manager 3.

Function name	Initial value	Configurable value or numerical range
Output operation mode	Unblocking/blocking information	Disabled, unblocking/blocking information, input signal linkage*1, and output information

Setting when selecting output information

ABI pattern	Function	Initial value	Configurable item
Red	Output operation mode	Safety output information	*2
	Inverted signal output	Enabled	Enabled/disabled
	Output pattern	Solid-ON	Solid-ON, ON 1 time, ON 2 times, and ON 3 times
Orange	Output operation mode	Stable state information	*2
	Inverted signal output	Enabled	Enabled/disabled
	Output pattern	ON 1 time	Solid-ON, ON 1 time, ON 2 times, and ON 3 times
Green	Output operation mode	Safety output information	*2
	Inverted signal output	Disable	Enabled/disabled
	Output pattern	Solid-ON	Solid-ON, ON 1 time, ON 2 times, and ON 3 times

*1. It is unable to use input signal linkage and the muting function together. To enable the setting of input signal linkage, disable the muting function.

In addition, for the following functions, setting parameters are kept individually in each case that the muting function is set enabled or disabled. When changing the muting state from enabled to disabled or vice versa using SD Manager 3, confirm the setting of the respective functions again.

Functions influenced:

External device monitoring, start interlock, restart interlock, and auxiliary output

*2. Configurable items are equal to the information assigned to the auxiliary output. For the details of the information assigned to the auxiliary output, refer to Section 2-12. "Auxiliary Output."



It is recommended that the Position 2 of the DIP Switch be set at OFF (DIP Switch Disabled).

CHECK!



For the details of change of setting parameters using SD Manager 3, refer to 4-3-3-3. *Area Beam Indicator (ABI)*.

2-23. Designated Beam Output

F3SG-SRA	✓	F3SG-PGA-A	✓	F3SG-PGA-C	✓
F3SG-SRB	✓	F3SG-PGA-L	✓		

2-23-1. Overview

This function allows information on unblocked/blocked states of a given beam to be output.

Example:

- To turn Area Beam Indicator (ABI) ON when a specified beam of the F3SG-SR is blocked
- To output, from the auxiliary output, a signal of information on a specified beam being unblocked

If one or more specified beams are blocked or unblocked, the information on the beam state can be provided as an auxiliary output or Area Beam Indicator (ABI).

Operation Example

Designated beam state: Dark-ON

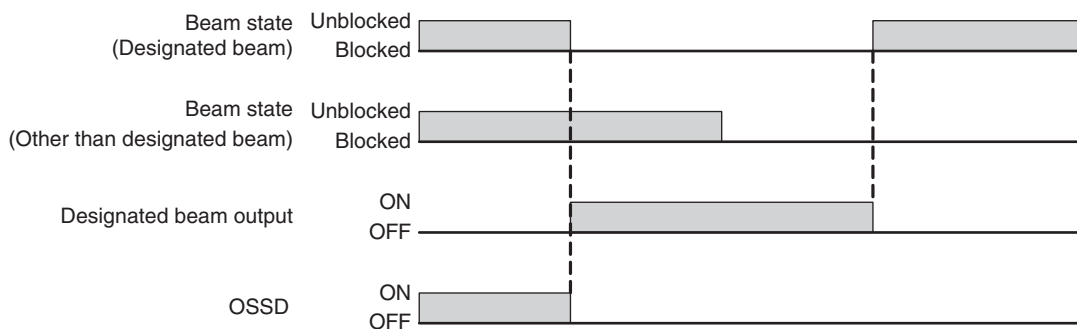
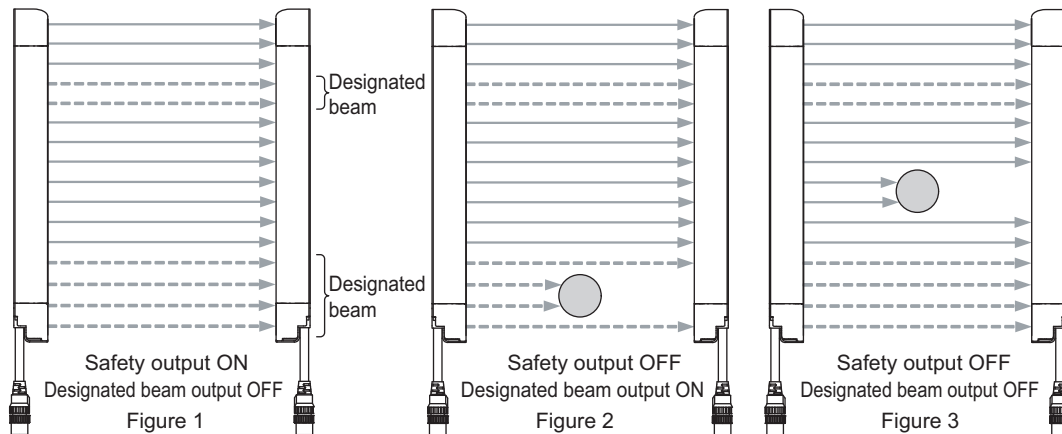

2-23-2. Factory Default Setting

Designated Beam Output is disabled.

2-23-3. Setting with Intelligent Tap

The user cannot make any changes to the settings of this function by the DIP Switch on the Intelligent Tap.

2-23-4. Setting with SD Manager 3

The user can make changes to the settings of this function by the SD Manager 3.

Function		Initial value	Configurable value or numerical range
Designated beam output		Disable	Enable/Disable
Setting by		Manual	Manual/Teach-in
Designated beam zone	Bottom beam	-	Any beam in 1-beam increments
	Top beam	-	
Designated beam state		Light-ON	Light-ON/Dark-ON

The designated beam setting can be changed using SD Manager 3. The number of areas available for setting of designated beam area is 1. If you want to output the light unblocked/blocked states of a designated beam, set the output operation mode of the Auxiliary Output to Designated beam output information.



CHECK!

It is recommended that the Position 2 of the DIP Switch be set at OFF (DIP Switch Disabled).



Refer to 4-3-3-2. *Designated Beam Output* for more information on setting this function by the SD Manager 3.

2-24. Stable Light Threshold Adjustment

F3SG-SRA	✓	F3SG-PGA-A	✓	F3SG-PGA-C	✓
F3SG-SRB	✓	F3SG-PGA-L	✓		

2-24-1. Overview

The threshold value to judge if the unblocked light quantity of a beam is stable or not can be changed. The threshold value to judge as unblocked is equal to 100%.

The judging status of stable unblocking can be monitored by changing the threshold value according to the operating environment and assigning the stable unblocking information to the auxiliary output and the area beam indicator (ABI).



When the stable light threshold value is changed, the following threshold values of the output information are also changed.

- CHECK!**
- Auxiliary Output: Stable-state information and Light level diagnosis information (upper limit)
 - Area Beam Indicator: Stable-state information and Light level diagnosis information (upper limit)
 - IO-Link Process Data: Light level diagnosis information (upper limit)



For the details of the information assigned to the auxiliary output, refer to 2-12. *Auxiliary Output*.

2-24-2. Factory Default Setting

The threshold value is set to 170%.

2-24-3. Setting Change using Intelligent Tap

It is unable to change the setting of this function using the DIP Switch of the Intelligent Tap.

2-24-4. Setting Change using SD Manager 3

The following setting can be made using SD Manager 3.

Function name	Initial value	Configurable value or numerical range
Stable light threshold	170%	100-300% (by 10%)



It is recommended that the Position 2 of the DIP Switch be set at OFF (DIP Switch Disabled).

CHECK!



For the details of the setting change using SD Manager 3, refer to 4-3-5-2. *Stable Light Threshold Adjustment*.

2-25. Incident/Ambient Light Level Monitoring

F3SG-SRA	✓	F3SG-PGA-A	✓	F3SG-PGA-C	✓
F3SG-SRB	✓	F3SG-PGA-L	✓		

2-25-1. Incident Light Level Information

2-25-1-1. Overview

The user can use the SD Manager 3 or SD Manager Mobile APP to read incident light level of the F3SG-SR/PG and view on a screen. This function allows beam adjustment while checking incident light level.

2-25-1-2. Setting with SD Manager 3

The user can enable this function to retrieve incident light level information. Making any changes to the function is not possible. (When the F3SG-SR is in the cascade connection, incident light level of each segment can be retrieved.)

2-25-2. Ambient Light Level Information

2-25-2-1. Overview

The user can use the SD Manager 3 or SD Manager Mobile APP to read incident light level of ambient light from a photoelectric sensor or another F3SG-SR/PG unit in a close area and view it on a screen. This function allows the user to identify a photoelectric sensor radiating ambient light or beams being affected by the light.

2-25-2-2. Setting with SD Manager 3

The user can enable this function to retrieve ambient light level information. Making any changes to the function is not possible. (When the F3SG-SR is in the cascade connection, ambient light level of each segment can be retrieved.)



Refer to 4-4-1-1. *Incident Light/Ambient Light* for more information on setting this function by the SD Manager 3 or SD Manager Mobile APP.

2-26. Lamp

F3SG-SRA	✓	F3SG-PGA-A	✓	F3SG-PGA-C	✓
F3SG-SRB	✓	F3SG-PGA-L	✓		

2-26-1. Functional Description

By connecting a lamp (optional: F39-SGLP) to the F3SG-SR/PG, the lamp can display the light-unblocked/blocked state of beams, the internal state of the sensor, and the external wiring state. Scan codes can be set during optical synchronization.

Application:

- To indicate that the F3SG-SR/PG is under muting or overriding
- To indicate that the F3SG-SR/PG is under lockout
- To indicate light reception status of F3SG-SR/PG
- To indicate that the machine is halted (control output is OFF)

The lamp can display red, orange, and green. By saving the settings in the F3SG-SR/PG, one of three different states can be assigned to each color. If lamp indication conditions are the same, indication is prioritized: Red > Orange > Green solid-ON/flashing. For the lamp's factory default setting, refer to 2-26-3. *Factory Default Setting*.



- When a lamp is connected to the F3SG-SR/PG and F3SG-PGA-A/L, it can only be used on the receiver side during optical synchronization. In case of wired synchronization, it can be used on both receiver and emitter.
- When a lamp is connected to the F3SG-PGA-C, it must be connected to the emitter / receiver.

■ Scan Code Switching by Lamp on Optical Synchronization

Using the rotary switch above the lamp, you can configure the scan code on optical synchronization to either code A or B. To change the scan code, make sure that power of F3SG-SR/PG is OFF. Under wired synchronization, scan code switching is not necessary.

Rotary switch

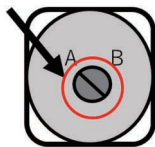

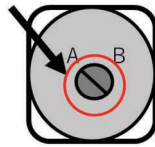
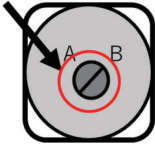
Setting	Overview
Rotary switch 	Scan code A (factory default setting)
Rotary switch 	Scan code B

* Recommended torque of rotary switch: 0.2 N•m max.



For more information on the optical synchronization/wired synchronization, refer to 2-3. *Mutual Interference Prevention*.

When connected to the F3SG-PGA-C, it must be connected to the emitter and receiver.

2-26-2. Installation to Main Unit

Remove the end cap attached to the TOP end of F3SG-SR/PG, and attach the lamp. If the F3SG-SR/PG is cascaded, attach the lamp to the secondary sensor farthest from the power supply.



For installation details, refer to lamp's operation manual.

2-26-3. Factory Default Setting

The rotary switch of the lamp is set as scan code A. See below for lamp's default lighting settings.

Light unblocked/blocked status	Red (priority 1)	Orange (priority 2)	Green (priority 3)
Output operation mode	Control output information	Stable unblocked information	Control output information
Output reverse function	Enabled	Enabled	Disabled
Output pattern	Solid ON	ON 1 time	Solid ON



When a lamp is connected to the emitter side of the F3SG-SR/PG and F3SG-PGA-A/L and operated under the optical synchronization setting, the lamp always remains OFF.

2-26-4. Setting with Intelligent Tap

The user cannot make any changes to the settings of this function by the DIP Switch on the Intelligent Tap.

2-26-5. Setting with SD Manager 3

The user can use SD Manager 3 to configure the settings of this function for each lamp color.

Color	Function name	Initial value		Available setting item
		Muting function enabled*1	Muting function disabled*1	
Red (priority 1)	Output operation mode	Control output information	Control output information	*2
	Output reverse function	Enable	Enable	Enable/Disable
	Output pattern	Solid ON	Solid ON	Solid-ON/ON 1 time/ON 2 times/ON 3 times
Orange (priority 2)	Output operation mode	Stable unblocked information	Stable unblocked information	*2
	Output reverse function	Enable	Enable	Enable/Disable
	Output pattern	ON 1 time	ON 1 time	Solid-ON/ON 1 time/ON 2 times/ON 3 times
Green (priority 3)	Output operation mode	Control output information	Control output information	*2
	Output reverse function	Disable	Disable	Enable/Disable
	Output pattern	Solid ON	Solid ON	Solid-ON/ON 1 time/ON 2 times/ON 3 times

* 1. This function retains the setting value individually for each of the muting function setting enabled/disabled. If you changed the muting function with SD Manager 3 from Enabled to Disabled or the other way around, check the settings of this function again.



• For details, refer to 2-1. *Combination of Functions*, ■ *Considerations for enabling and disabling Muting function with SD Manager 3*.

• For the muting function's settings, refer to 2-13. *Muting*.

*2. Refer to "Information assigned to lamp".

*3. Output by the pattern described in "output pattern chart".

■ Output pattern chart

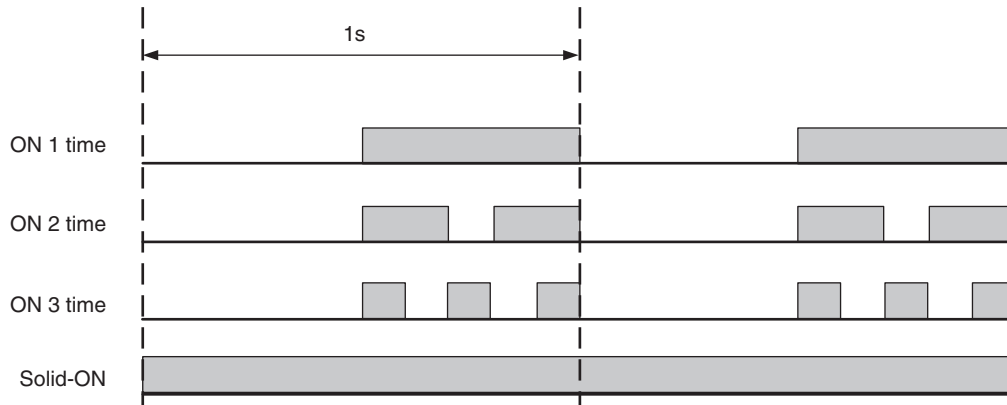

Information assigned to lamp

Information Name	Description (Lamp output is turned ON under the following condition.)
Safety output information	When the safety outputs are in the ON state
Interlock information	Under the INTERLOCK state
Lockout information	Under the LOCKOUT state
Excess power-on time information	When power-on time exceeds power-on time threshold
Excess load switching frequency information	When load switching frequency exceeds load switching frequency threshold
Stable-state information	When light intensity, which is constantly monitored, is 170% or higher of ON-threshold
Muting information	Under the MUTING state
Override information	Under the OVERRIDE state
Muting/Override information	Under either the MUTING or OVERRIDE state
Light level diagnosis information	When the F3SG-SR/PG is unblocked and light intensity is within a range from 100% to 170% of ON-threshold for 10 s or longer
Warning Zone Information*1	When warning zone is blocked
PSDI Information*1	When the F3SG-SR is ready to be blocked for feeding or removing parts
Blanking beam unblocked information	When Fixed-Blanking or Floating Blanking beams are unblocked
Troubleshooting support signal	When one of the signals of Sequence error information, instantaneous block information and Light level diagnosis information is in the ON state.
Designated beam output information	When a designated beam is blocked or unblocked
Sequence error information	Under the MUTING SEQUENCE ERROR state or the INTERLOCK SEQUENCE ERROR state
Reset-input information	When RESET/EDM/Override input is in the ON state
Mute A input signal information	When MUTE A input is in the ON state
Mute B input signal information	When MUTE B input is in the ON state
EDM input information	When EDM signal input is in the ON state
Individual cascaded sensor output (Channel 1)	When the safety outputs of the primary sensor in cascade connection are in the ON state
Individual cascaded sensor output (Channel 2)*1	When the safety outputs of the 1st secondary sensor in cascade connection are in the ON state
Individual cascaded sensor output (Channel 3)*1	When the safety outputs of the 2nd secondary sensor in cascade connection are in the ON state
Blanking/Warning-zone information*1	When Fixed Blanking, Floating Blanking, Reduced Resolution or Warning Zone function is enabled
Instantaneous block information	When the F3SG-SR/PG system stops accidentally due to interference or vibration. (In case of cascade connection, when any of cascaded segments comes under this condition.)
Pre-reset Information	Under Pre-reset state
Communication quality diagnosis information	Assigned when retry occurs in communications due to noise or short-circuit of the communication line.
Recoverable error information	Assigned when a recoverable error occurs.
Replacement-recommended error information	Assigned when a replacement-recommended error occurs.
None (OFF)	This function is disabled.

*1. Not supported by F3SG-PG.



It is recommended that the Position 2 of the DIP Switch be set at OFF (DIP Switch Disabled).

CHECK!



For details of function change by SD Manager 3, 4-3-3-1. Auxiliary Output/Lamp.

2-27. Maintenance Information

F3SG-SRA	✓	F3SG-PGA-A	✓	F3SG-PGA-C	✓
F3SG-SRB	✓	F3SG-PGA-L	✓		

2-27-1. Overview

You can use the SD Manager 3 or SD Manager 3 Mobile APP to read the maintenance information of F3SG-SR/PG to view on a PC screen. The Maintenance Information function indicates the following information:

- Error Log
- Warning Log
- Power-On Time *
- Load Switching Frequency *
- Muting Statistics Information

* The setting parameters of power ON time threshold and load switching frequency threshold cannot be changed using SD Manager 3 Mobile APP.



Refer to 4-4-3. *Maintenance Information* for more information on setting this function by the SD Manager 3.

2-27-2. Error Log

The user can view details of errors occurred in the past. The error information is recorded in the F3SG-SR/PG main unit when an error occurs. The displayed information is useful for troubleshooting. Up to 50 past errors can be recorded. The information is displayed for the emitter and receiver, respectively.



CHECK!

In case of F3SG-PGA-C emitter/receiver, you can check for the emitter and receiver in it respectively.



- For how to check error history by SD Manager 3, refer to 4-4-3-1. *Error Log Information*.
- For how to check error history by SD Manager 3 Mobile APP, refer to 4-5-5-3. *Maintenance Information*.

2-27-3. Warning Log

The user can view details of the following warnings occurred in the past. The warning information is recorded in the F3SG-SR/PG main unit when a warning occurs. The displayed information can be used for troubleshooting. Up to 50 past warnings can be recorded. The information is displayed for the emitter and receiver, respectively.

- Muting sequence error
- Interlock sequence error
- Interference/vibration information



CHECK!

In case of F3SG-PGA-C emitter/receiver, you can check for the emitter and receiver in it respectively.



- For how to check warning history by SD Manager 3, refer to 4-4-3-2. *Warning Log*.
- For how to check warning history by SD Manager 3 Mobile APP, refer to 4-5-5-3. *Maintenance Information*.

2-27-4. Power-ON Time

The user can view the following information related to the power-on time of the F3SG-SR/PG. The power-on time information is recorded in the F3SG-SR/PG main unit every 15 minutes. This information is useful to better understand when to schedule of the F3SG-SR/PG.

- Power-on time threshold

It is possible to give an output signal to the auxiliary output or indicate with Area Beam Indicator (ABI) when the power-on time exceeds the power-on time threshold. The excess power-on time information must be assigned to the output operation mode of the auxiliary output or Area Beam Indicator (ABI).



For the details of the information assigned to the auxiliary output, refer to 2-12. *Auxiliary Output*.

- Power-on time

This is the current power-on time since the power-on time was last reset. If the power-on time has never been reset, this value is the same as the accumulated power-on time. The information is displayed for the emitter and receiver, respectively.

- Accumulated power-on time

This is the cumulative power-on time, from when the F3SG-SR/PG is powered on for the first time after purchase until the present. It is not possible to reset this value by the power-on time reset function.

- Power-on time reset

This function can reset the power-on time of the F3SG-SR/PG to zero. When the F3SG-SR/PG is in cascade connection, the power-on time can be reset for each cascaded F3SG-SR/PG segment.

The user can make changes to the settings by the SD Manager 3.

Function	Initial value	Configurable value or numerical range
Power-on time threshold	30,000 h	30,000 to 1,000,000 h in 1-h increments/Disable



In case of F3SG-PGA-C emitter/receiver, you can check for the emitter and receiver in it respectively.

CHECK!



For how to check and configure setting by SD Manager 3, refer to 4-4-3-4. *Power-On Time/Load Switching Frequency*.

2-27-5. Load Switching Frequency

The user can view the number of switching operations of the load connected to the F3SG-SR/PG. The load switching frequency information is recorded in the F3SG-SR/PG main unit every 15 minutes. This information is useful to understand the switching frequency of relays and contactors connected to the F3SG-SR/PG.

- Load switching frequency threshold

It is possible to give an output signal to the auxiliary output or indicate with Area Beam Indicator (ABI) when the switching frequency exceeds the switching frequency threshold. The excess load switching frequency information must be assigned to the output operation mode of the auxiliary output or Area Beam Indicator (ABI).



For the details of the information assigned to the auxiliary output, refer to 2-12. *Auxiliary Output*.

- Load switching frequency

This is the switching frequency of the load connected to the F3SG-SR/PG. When the F3SG-SR/PG is in cascade connection, the load switching frequency can be reset for each cascaded F3SG-SR/PG segment.

- Accumulated load switching frequency

This is the cumulative load switching frequency, from when the F3SG-SR/PG is powered on for the first time after purchase until the present. It is not possible to reset this value by the load switching frequency reset function.

- Load switching frequency reset

This function can reset the load switching frequency of the F3SG-SR/PG to zero. When the F3SG-SR/PG is in cascade connection, the load switching frequency can be reset for each cascaded F3SG-SR/PG segment. Use this reset function whenever you install or replace relays or contactors.

The user can make changes to the settings by the SD Manager 3.

Function	Initial value	Configurable value or numerical range
Load switching frequency threshold	100,000 times in 1-time increment	100,000 to 4,000,000 times in 1-time increments/Disable

 For how to check and configure setting by SD Manager 3, refer to 4-4-3-4. *Power-On Time/Load Switching Frequency*.

2-27-6. Muting Statistics Information

This function logs and visualizes conditions of the F3SG-SR/PG muting operations to help the user adjust settings of muting input time difference. Also, its statistic calculation allows for optimal settings with reduced test runs.

 Refer to 4-3-4-3. *Muting/Override* for more information on using this function by the SD Manager 3 or SD Manager 3 Mobile APP.

2-27-7. Intelligent Tap Log

You can use the SD Manager 3 to read the maintenance information (Error Log / Accumulated power-on time) of the Intelligent Tap to view on a PC screen. The Maintenance Information function indicates the following information:

- Error Log

The user can view details of errors occurred in the past. The error information is recorded in the Intelligent Tap at the time of occurrence of an error. The displayed information is useful for troubleshooting. Up to 50 past errors can be recorded.

- Accumulated power-on time

The user can view an accumulated value of power-on time from when the Intelligent Tap is powered on for the first time after purchase until the present. It is not possible to reset this value by the power-on time reset function.

 For how to check by SD Manager 3, refer to 4-4-3-3. *Intelligent Tap Log*.

2-28. Operating Status Monitoring

F3SG-SRA	✓	F3SG-PGA-A	✓	F3SG-PGA-C	✓
F3SG-SRB	✓	F3SG-PGA-L	✓		

2-28-1. Overview

I/O information and the state of the F3SG-SR/PG can be read out with the SD Manager 3.



Refer to 4-4-1-2. *Operating Status Monitoring* for more information on using this function by the SD Manager 3 or SD Manager 3 Mobile APP.

2-28-2. Readout Information

The following information is displayed related to F3SG-SR/F3SG-PGA-A/-L receiver and F3SG-PGA-C emitter/receiver.

The information is displayed in a block in case of a cascade connection of F3SG-SR.

Information name		Description
External wiring information	Power Supply	Displays a supply voltage being supplied
	OSSD 1 (Black)	Linked to OSSD 1 signal
	OSSD 2 (White)	Linked to OSSD 2 signal
	RESET (Yellow)	Linked to Reset/External Device Monitoring (EDM)/Override input signal
	AUX (Red)	Linked to Auxiliary output signal
	MUTE A (Gray)	Linked to Muting input A/Pre-Reset/PSDI input
	MUTE B (Pink)	Linked to Muting input B
Sensor Information	Scan code	Displays Scan Code setting
	EDM	Displays EDM setting
	Interlock/Pre-Reset/PSDI	Displays Interlock/Pre-Reset/PSDI setting
	Fixed/Floating Blanking	Displays Fixed/Floating Blanking setting
	PNP/NPN	Displays output mode (PNP/NPN) setting
	DIP Enable/Disable	Displays whether the settings by the DIP Switches of the intelligent tap are enabled or disabled.
Operating Status	Muting information	Linked to the MUTING state
	Override information	Linked to the OVERRIDE state
	Sequence error information	Linked to the MUTING SEQUENCE ERROR state or the INTERLOCK SEQUENCE ERROR state
	Safety output information	Linked to safety output signal
	Push-SW information	Linked to the input signal of Push Switch on Intelligent Tap
	Blanking beam unblocked information	Linked to the state where the blanking beam is unblocked

2-29. Instantaneous Block Detection

F3SG-SRA	✓	F3SG-PGA-A	✓	F3SG-PGA-C	✓
F3SG-SRB	✓*1	F3SG-PGA-L	✓		

*1. F3SG-SRB does not record oscillation.

2-29-1. Overview

When instantaneous blocking is detected, the beam number and occurrence time of the detection are recorded.

You can use the SD Manager 3 to read the instantaneous block detection information of F3SG-SR to view on a PC screen. The instantaneous block detection information indicates the following information:

- Blocked axis

If blocking occurs on more than one beam, the number of the beam which detected the blocking first is recorded. The beam numbers are serial numbers beginning with one, assigned from the power cable side to the termination cap side.



CHECK!

The instantaneous blocking means blocking within the time calculated as the ON to OFF response time of each sensor multiplied by 0.5 to 1.5. If the response time is changed by the Response Time Adjustment function, the detection time changes according to the change.

- Presence of vibration

The presence of vibration is recorded at the time of detection of instantaneous blocking.



CHECK!

F3SG-SRB does not record oscillation.

- Accumulated power-on time

The accumulated value of power-on time is recorded at the time of detection of instantaneous blocking.

2-29-2. Factory Default Setting

The instantaneous blocking detection is set as disabled.

2-29-3. Setting Change using Intelligent Tap

It is unable to change the setting of this function using the Intelligent Tap.

2-29-4. Setting Change using SD Manager 3

The following setting can be done using SD Manager 3.

Function	Initial value	Configurable value or numerical range
Instantaneous block detection Information	Unblocking/blocking information	Disabled, unblocking/blocking information, input signal linkage*1, and output information



For the details of the setting change using SD Manager 3, refer to 4-4-3-5. *Instantaneous Block Detection Information*.

2-30. Setting Recovery

F3SG-SRA	✓	F3SG-PGA-A	✓	F3SG-PGA-C	✓
F3SG-SRB	✓	F3SG-PGA-L	✓		

You can use the SD Manager 3 to recover the F3SG-SR/PG setting to the default factory setting.



It is recommended that the Position 2 of the DIP Switch be set at OFF (DIP Switch Disabled).

CHECK!



Refer to 4-4-3. *Maintenance Information* for more information on setting this function by the SD Manager 3.

2-31. Backup/Restoration

F3SG-SRA	✓	F3SG-PGA-A	✓	F3SG-PGA-C	✓
F3SG-SRB	✓	F3SG-PGA-L	✓		

2-31-1. Overview

Implement restoration or copying of the settings of F3SG-SR/PG using the Intelligent Tap.

■ Backup

This is the function to save the configuration of F3SG-SR/PG in the Intelligent Tap.

■ Restoration

This is the function to write the configuration saved in the Intelligent Tap into F3SG-SR/PG.



Both backup and restoration do not need SD Manager 3 and can be implemented even if multiple sensors are connected with each other.

CHECK!



For details, refer to 3-6. *Backup/Restoration*.

2-31-2. Factory Default Setting

The Backup/Restoration function is enabled by default.

The operation settings are configured as follows: Backup: Manual Operation, Restoration: Auto Operation

2-31-3. Setting Change using Intelligent Tap

It is unable to change the setting of this function using the DIP Switch of the Intelligent Tap.

2-31-4. Setting Change using SD Manager 3

The following settings can be modified using SD Manager 3:

Feature Name	Default Value	Configurable Options
Backup/Restoration	Enable	Enable / Disable
Operation Settings	Backup: Manual Operation, Restoration: Auto Operation	Backup: Manual Operation, Restoration: Auto Operation / Backup: Manual Operation, Restoration: Manual Operation



Refer to 4-3-7. *Backup/Restoration* for details on configuration changes using SD Manager 3.

2-32. IO-Link

WARNING

Do not use the output signal of the IO-Link output for safety applications. Failure to do so may result in serious injury when the F3SG-SR/PG fails.



F3SG-SRA	✓	F3SG-PGA-A	✓	F3SG-PGA-C	✓
F3SG-SRB	✓	F3SG-PGA-L	✓		

By using the Intelligent Tap as an IO-Link device, sensor's configuration and monitoring information can be provided via the IO-Link master.



For the details of the IO-Link communications using the Intelligent Tap, refer to 3-9. *IO-Link*.

Chapter 3 Setting with Intelligent Tap

3-1. List of Functions Configurable by Intelligent Tap and Initial Setup Method	153
3-1-1. Functions Configurable by Intelligent Tap	153
3-1-2. Initial Setup Method after Purchase	153
3-2. Connection	154
3-3. Wiring	157
3-4. LED Indicators on Intelligent Tap	158
3-5. DIP Switch on Intelligent Tap	159
3-6. Backup/Restoration	161
3-6-1. Description of Functions	161
3-6-2. Performing Backup	162
3-6-3. Performing Restoration	164
3-6-4. Various Usage of Backup and Restoration	168
3-6-4-1. Plug and Work	168
3-6-4-2. Copy and Paste of Sensor Settings	168
3-6-4-3. Changing F3SG-SR/PG Configuration to Connect to Intelligent Tap	168
3-6-4-4. Changing F3SG-SR/PG's Settings with Intelligent Tap DIP Switch	168
3-7. Teach-in (Fix Blanking / Floating Blanking)	169
3-7-1. Setting Fixed Blanking by Teach-in	169
3-7-2. Setting Floating Blanking by Teach-in	174
3-8. Connection to SD Manager 3	178
3-9. IO-Link	179
3-9-1. Functional Description	179
3-9-2. Communication Specifications	179
3-9-3. Process Data	179
3-9-4. Service Data	182

3-10. Intelligent Tap Application Example	186
3-10-1. Setting F3SG-SR/PG with DIP Switch	186
3-10-2. Saving Sensor Setting to Intelligent Tap Using Backup Function	188
3-10-3. Applying Setting Saved in Intelligent Tap to Sensor Using Restoration	190
3-10-4. Replacing Intelligent Tap	193

3-1. List of Functions Configurable by Intelligent Tap and Initial Setup Method

3-1-1. Functions Configurable by Intelligent Tap

The following functions are configurable by the DIP Switch on the Intelligent Tap (F39-SGIT-IL3).

Function	Page
Interlock	61
Pre-Reset	64
External Device Monitoring (EDM)	70
Fixed Blanking	108
Floating Blanking	114
Operating Range Selection	128



CHECK!

No password is required for configuring the functions by the DIP Switch on the Intelligent Tap. Make sure the Responsible Person keeps the Intelligent Tap properly.

3-1-2. Initial Setup Method after Purchase

When connecting the Intelligent Tap to the F3SG-SR/PG for the first time after purchase, you need to make the following settings.

1. Connect the Intelligent Tap to the F3SG-SR/PG. Set the Intelligent Tap DIP-SW as factory default settings. As shown below, set the DIP switch channel 1 as ON (lock) and channels 2 to 8 as OFF.

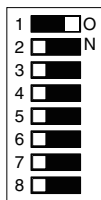

: Indicates the switch position.

2. Turn the power on. Then the Intelligent Tap performs the Backup automatically and restarts itself.
3. If the DIP Switch Position 1 is set at ON (Lock), the F3SG-SR/PG performs its normal operation.
4. Operate according to the usage below.
 - Setting with DIP Switch
Turn the power off and operate referring to the following chapter(s).
3-5. DIP Switch on Intelligent Tap and 3-6-3. Performing Restoration
 - Setting with SD Manager 3
Connect a USB-C™ cable to the Intelligent Tap and operate referring to the following chapter(s).
Chapter 4 Setting with SD Manager 3
 - Setting not needed
Use the devices as they are.



CHECK!

- When the DIP Switch Position 1 is set at OFF (Unlock) in the step 1 and 2, the Intelligent Tap and the F3SG-SR/PG are waiting for the Backup operation (or waiting for Push Switch operation). In this case, turn the power off, then switch the DIP Switch Position to ON (Lock) and turn the power on again. After this, the F3SG-SR/PG performs its normal operation.
- If you write settings with SD Manager 3 to the Intelligent Tap alone before you connect the Intelligent Tap to the F3SG-SR/PG for the first time after purchase, the Backup is not started automatically. Operate according to the Backup procedure. For more information on the Backup procedure, refer to 3-6-2. *Performing Backup*.
- During backup or restore operations, the SD Manager 3 cannot be connected.

3-2. Connection

Shown below is a connection example of the Intelligent Tap, F3SG-SR, PC and IO-Link Master. For other connection examples, refer to 4-1-3-1. *Connection Patterns of F3SG-SR/PG, Intelligent Tap, and Each Device.*

For IO-Link master details, see the manual of the IO-Link to connect.

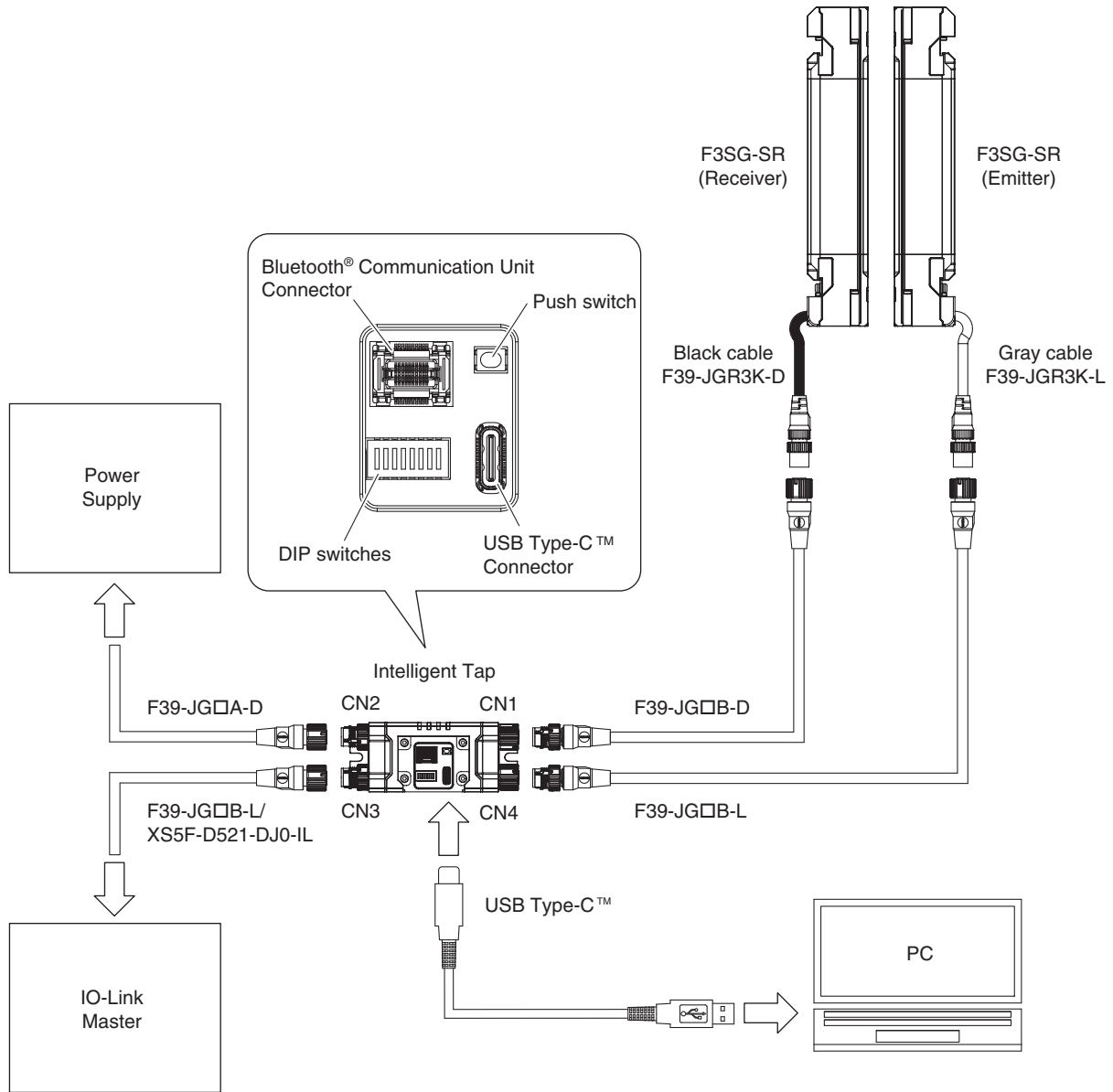

If you do not want to permanently install an Intelligent Tap and use an Intelligent Tap as needed, please temporarily change the wiring as shown below.

	Current Usage (When the Intelligent Tap is Not in Use)	When using the Intelligent Tap
the Optical Synchronization	<p>When extending the cable (up to 100m)</p>	<p>For permanent use (wired synchronization)</p> <p>When extending the cable (up to 100m)</p>
	<p>Remarks</p> <p>[Task] Insert an Intelligent Tap between cables (2) and (4) (or between cables (4) and (6)).</p> <p>[Caution] • Configuration changes/monitoring on the emitter side are not allowed.</p>	
the wired synchronization	<p>When extending the cable (up to 100m)</p>	<p>For permanent use (wired synchronization)</p> <p>When extending the cable (up to 100m)</p>
	<p>Remarks</p> <p>[Task] Insert an Intelligent Tap between cables (2) and (4) (or between cables (4) and (6)). Connect cable (1) or (3) to the Intelligent Tap.</p> <p>[Caution] • The test function on the emitter side cannot be used. • The detection range selection on the emitter side operates based on the DIP switch settings of the Intelligent Tap or the configuration information (settings from SD Manager3).</p>	

- (1) F39-JGR3K-L
- (2) F39-JGR3K-D
- (3) F39-JG□B-L
- (4) F39-JG□A-D
- (5) F39-JG□A-L
- (6) F39-JG□B-D

For F3SG-SR-K, use a terminal block to connect to an intelligent tap as it is the open-ended type. The figure below shows a connection example of F3SG-SR-K and the intelligent tap.

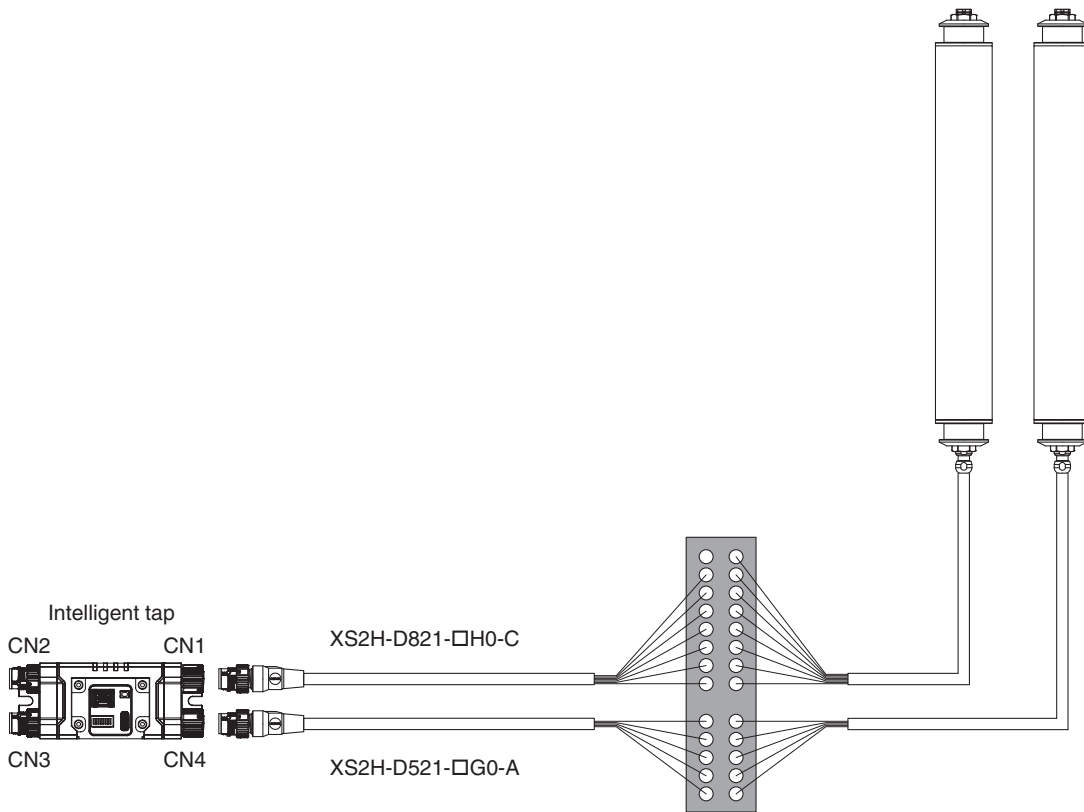

Terminal #	Terminal name	Wire color	
		XS2H-D821-□H0-C	F3SG-SR-K receiver
1	Reset Input/External Device Monitoring	White	Yellow
2	+24V	Brown	Brown
3	Communication line (+)	Green	Gray
4	Communication line (-)	Yellow	Pink
5	Control Output 1	Gray	Black
6	Control Output 2	Pink	White
7	0V	Blue	Blue
8	Auxiliary Output	*	Red

Terminal #	Terminal name	Wire color	
		XS2H-D521-□G0-A	F3SG-SR-K emitter
1	+24V	Brown	Brown
2	TEST	White	Black
3	0V	Blue	Blue
4	Communication line (+)	Black	White
5	Communication line (-)	Gray	Yellow

* To use the auxiliary output, the line must be wired separately from that of the Intelligent Tap.



CHECK!

If UL certification is required for the entire machine, you must select the terminal block that connects the F3SG-SR-K and the intelligent tap as a UL-approved FW2 product.

3-3. Wiring

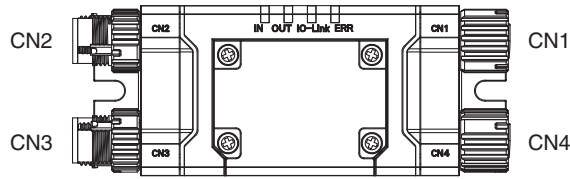

<Internal wiring diagram>

CN2																									
	<table border="1"> <tr> <td>RESET/EDM</td> <td>Yellow</td> <td>1</td> </tr> <tr> <td>24V/0V</td> <td>Brown</td> <td>2</td> </tr> <tr> <td>MUTE A/PRE-RESET/PSDI</td> <td>Gray</td> <td>3</td> </tr> <tr> <td>MUTE B</td> <td>Pink</td> <td>4</td> </tr> <tr> <td>OSSD 1</td> <td>Black</td> <td>5</td> </tr> <tr> <td>OSSD 2</td> <td>White</td> <td>6</td> </tr> <tr> <td>0V/24V</td> <td>Blue</td> <td>7</td> </tr> <tr> <td>AUX</td> <td>Red</td> <td>8</td> </tr> </table>	RESET/EDM	Yellow	1	24V/0V	Brown	2	MUTE A/PRE-RESET/PSDI	Gray	3	MUTE B	Pink	4	OSSD 1	Black	5	OSSD 2	White	6	0V/24V	Blue	7	AUX	Red	8
RESET/EDM	Yellow	1																							
24V/0V	Brown	2																							
MUTE A/PRE-RESET/PSDI	Gray	3																							
MUTE B	Pink	4																							
OSSD 1	Black	5																							
OSSD 2	White	6																							
0V/24V	Blue	7																							
AUX	Red	8																							

The wire colors are those of the F39-JG□A-D to be connected to the CN2.

CN1																	
	<table border="1"> <tr> <td>1</td> <td>RESET/EDM</td> </tr> <tr> <td>2</td> <td>+24V</td> </tr> <tr> <td>3</td> <td>COM(+)</td> </tr> <tr> <td>4</td> <td>COM(-)</td> </tr> <tr> <td>5</td> <td>OSSD 1</td> </tr> <tr> <td>6</td> <td>OSSD 2</td> </tr> <tr> <td>7</td> <td>0V</td> </tr> <tr> <td>8</td> <td>AUX</td> </tr> </table>	1	RESET/EDM	2	+24V	3	COM(+)	4	COM(-)	5	OSSD 1	6	OSSD 2	7	0V	8	AUX
1	RESET/EDM																
2	+24V																
3	COM(+)																
4	COM(-)																
5	OSSD 1																
6	OSSD 2																
7	0V																
8	AUX																

CN3																
	<table border="1"> <tr> <td>L+</td> <td>Brown</td> <td>1</td> </tr> <tr> <td>DO</td> <td>White</td> <td>2</td> </tr> <tr> <td>L-</td> <td>Blue</td> <td>3</td> </tr> <tr> <td>C/Q</td> <td>Black</td> <td>4</td> </tr> <tr> <td>Not used</td> <td>Yellow</td> <td>5</td> </tr> </table>	L+	Brown	1	DO	White	2	L-	Blue	3	C/Q	Black	4	Not used	Yellow	5
L+	Brown	1														
DO	White	2														
L-	Blue	3														
C/Q	Black	4														
Not used	Yellow	5														

The wire colors are those of the XS5F-D521-DJ0-IL to be connected to the CN3.

CN4											
	<table border="1"> <tr> <td>1</td> <td>+24V</td> </tr> <tr> <td>2</td> <td>TEST</td> </tr> <tr> <td>3</td> <td>0V</td> </tr> <tr> <td>4</td> <td>COM(+)</td> </tr> <tr> <td>5</td> <td>SIO-</td> </tr> </table>	1	+24V	2	TEST	3	0V	4	COM(+)	5	SIO-
1	+24V										
2	TEST										
3	0V										
4	COM(+)										
5	SIO-										

3-4. LED Indicators on Intelligent Tap

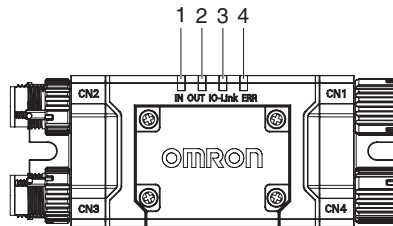

Shown below are indication statuses of LED indicators on the Intelligent Tap when you purchased.

Location	Indicator	Name	Color	Illuminated	Blinking
1	IN	Sensor status	Yellow	Safety outputs of the F3SG-SR/PG are in the ON state	The F3SG-SR/PG is in the LOCKOUT state. Or the Intelligent Tap is waiting for Push Switch operation (in the Backup) or the Intelligent Tap and F3SG-SR/PG are waiting for restart (in the Backup). Or communication error in the Backup or between the F3SG-SR/PG and the Intelligent Tap. Or the Restoration failed
2	OUT	Output status	Green	Outputs of the Intelligent Tap are in the ON state (*1)	The Restoration failed. Or in the Restoration, the Intelligent Tap has communication error, is waiting for Push Switch operation or transferring data, or the Intelligent Tap and F3SG-SR/PG are waiting for restart
			Red	Outputs of the Intelligent Tap are in the OFF state (*2)	Communication error between the F3SG-SR/PG and the Intelligent Tap
3	IO-Link	IO-Link	Green	-	Intelligent Tap communicates with IO-Link Master. Or IO-Link circuit error
4	ERR	Lockout	Red	The Intelligent Tap is in the LOCKOUT state, or has communication error, DIP Switch circuit error at startup, communication error in the Backup or Restoration, restoration failure, IO-Link circuit error, power supply voltage error or other errors	-

*1. When the safety outputs of the F3SG-SR/PG are in the ON state, the outputs of the Intelligent Tap are in the ON state.

*2. When the safety outputs of the F3SG-SR/PG are in the OFF state, the outputs of the Intelligent Tap are in the OFF state.



In the SETTING state to make settings with the SD Manager 3, the IN and OUT indicators blink. (IN: Yellow, OUT: Green)

CHECK!

For more information on the statuses of the LED indicators in the SETTING state, refer to 4-1-4. SETTING State of F3SG-SR/PG with SD Manager 3 Connected.

3-5. DIP Switch on Intelligent Tap

⚠ WARNING

Make sure the Responsible Person tests the operation of the F3SG-SR/PG after setting with the DIP Switch on the F39-SGIT-IL3 to verify that the F3SG-SR/PG operates as intended. Make sure to stop the machine until the test is complete. Unintended settings may cause a person to go undetected, resulting in serious injury.



The table below lists the positions and assigned functions of the DIP Switches on the Intelligent Tap.



For detailed steps to change the settings of F3SG-SR/PG using the DIP Switch, refer to 3-10-1. *Setting F3SG-SR/PG with DIP Switch.*

☐: Indicates a switch position.

Position	Function	Setting	Description
1	Lock/Unlock	1 <input type="checkbox"/> ON	Unlock
		1 <input checked="" type="checkbox"/> ON	Lock (factory default setting)
2	DIP Switch Enable/Disable	2 <input type="checkbox"/> ON	DIP Switch Disabled (factory default setting)
		2 <input checked="" type="checkbox"/> ON	DIP Switch Enabled
3	EDM	3 <input type="checkbox"/> ON	EDM Disabled (factory default setting)
		3 <input checked="" type="checkbox"/> ON	EDM Enabled
4, 5	Interlock/Pre-Reset	4 <input type="checkbox"/> ON 5 <input type="checkbox"/> ON	Auto Reset (factory default setting)
		4 <input checked="" type="checkbox"/> ON 5 <input type="checkbox"/> ON	Pre-Reset
		4 <input type="checkbox"/> ON 5 <input checked="" type="checkbox"/> ON	Manual Reset (Start/Restart Interlock)
		4 <input checked="" type="checkbox"/> ON 5 <input checked="" type="checkbox"/> ON	Auto Reset (same as Auto Reset (factory default setting))
		6 <input type="checkbox"/> ON 7 <input type="checkbox"/> ON	Blanking Disabled (factory default setting)
		6 <input checked="" type="checkbox"/> ON 7 <input type="checkbox"/> ON	Fixed Blanking Enabled
6, 7	Fixed Blanking/ Floating Blanking *1	6 <input type="checkbox"/> ON 7 <input checked="" type="checkbox"/> ON	Floating Blanking Enabled
		6 <input checked="" type="checkbox"/> ON 7 <input type="checkbox"/> ON	Blanking Disabled (same as Blanking Disabled (factory default setting))
		8 <input type="checkbox"/> ON	Long (factory default setting)
		8 <input checked="" type="checkbox"/> ON	Short

*1. Not supported by F3SG-PG.

*2. Not supported by F3SG-PGA-A/C.



CHECK!

When the DIP Switch Position 1 is set at ON (Lock), Position 2 at ON (DIP Switch Enabled) and Positions 3 to 8 at OFF*, the functions assigned to the Positions 3 to 8 operates according to the settings of the OFF positions and the following functions are set as described in the table below.

Item	Function	Setting
PSDI	PSDI	Disable
Muting	Muting	Enable
	Zone setting	All beams
Teach-in	Teach-in Input	Enable Teach-in by Push Switch
Area Beam Indicator	Output operation mode of Area Beam Indicator	Block/Unblock Information
Warning Zone	Warning Zone	Disable
Reduced Resolution	Reduced Resolution	Disable

* Refer to 2-1. *Combination of Functions* for settings to be affected when any of Positions 3 to 8 is set at ON.

3-6. Backup/Restoration

3-6-1. Description of Functions

F3SG-SR/PG series allow easier restoration or copy of F3SG-SR/PG's settings with an Intelligent Tap.

■ Backup

You can save the F3SG-SR/PG's settings to an Intelligent Tap.

■ Restoration

You can write the F3SG-SR/PG's settings saved in an Intelligent Tap to the sensor.



- You can perform both Backup and Restoration without the SD Manager 3 and even when the F3SG-SR/PG is in the cascade connection. When performing the Restoration, the sensor configuration saved in the Intelligent Tap must be the same as the actual sensor configuration. If the sensor configuration of other than the number of beams is not the same, perform the Backup of the connected F3SG-SR/PG and then perform the Restoration again. Refer to 3-6-3. *Performing Restoration* for the conditions to perform the Restoration.
- When the power is shut down or the F3SG-SR/PG is restarted by a reset input in the middle of the Backup or the Restoration, the Backup or the Restoration is interrupted. Start the Backup or the Restoration over again. Refer to 3-6-2. *Performing Backup* for the Backup procedure and 3-6-3. *Performing Restoration* for the Restoration procedure.

3-6-2. Performing Backup

⚠ WARNING

When performing the Backup, make sure to set the DIP Switch Position 1 at OFF (Unlock) before turning on the power. If the DIP Switch Position 1 is at ON (Lock), the Restoration is performed, which may case the settings of the F3SG-SR/PG to be overwritten and a person to go undetected, resulting in serious injury.



Follow the flowchart below to perform backup.

For detailed steps, refer to 3-10-2. *Saving Sensor Setting to Intelligent Tap Using Backup Function.*

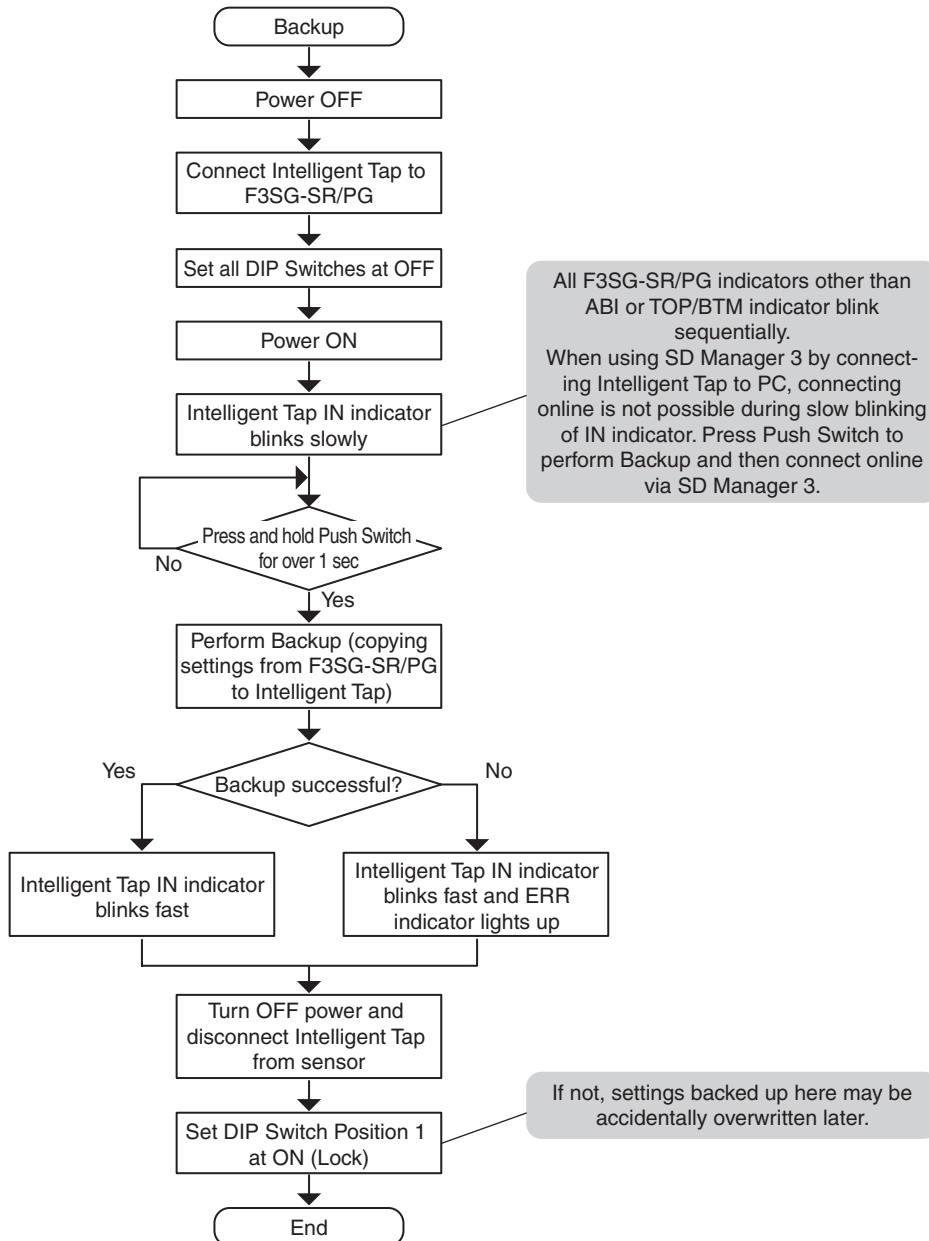

To run the Intelligent Tap while being connected to the F3SG-SR/PG, you must save the F3SG-SR/PG's settings in the Intelligent Tap by the backup operation. After performing the Backup, set the DIP Switch Position 1 at ON (Lock) and connect the Intelligent Tap to the F3SG-SR/PG.

If the Intelligent Tap is under the factory shipment status, the Backup will be automatically performed even if DIP Switch Position 1 is set at ON (Lock) as it has no backup data in it. Unlike the normal Backup, you do not have to operate the Push Switch nor restart the device after the end of the Backup.

The Backup saves the F3SG-SR/PG's setup information in the Intelligent Tap which is automatically restarted and performs its normal operation.

■ LED indication during Backup

Function		Indicator			
Mode	State	IN (Yellow)	OUT (Green/Red)	IO-Link (Green)	ERR (Red)
Backup	Transitioning modes			--	
	Waiting for Push Switch operation				
	Transferring data				
	Waiting for restart after Backup				
	Waiting for restart due to communication error				



3-6-3. Performing Restoration

WARNING

When performing the Restoration, make sure to set the DIP Switch Position 1 at ON (Lock) before turning on the power. If the DIP Switch Position 1 at OFF (Unlock), the Backup is performed, which may cause the settings of the Intelligent Tap to be overwritten and a person to go undetected, resulting in serious injury.



When the Restoration is performed, if the DIP Switch Position 2 is at ON (DIP Switch Enabled) and settings of the DIP Switch Positions 3 to 8 are different from the backup data in the F39-SGIT-IL3, the settings in the DIP Switch takes priority and are saved in the F3SG-SR/PG. To prevent such an accident, it is recommended that you set the DIP Switch Position 2 at OFF before performing the Restoration when you use the settings backed up from the F3SG-SR/PG or make settings with the SD Manager 3.



CHECK!

- When performing the Restoration of the backup data saved in the Intelligent Tap to the F3SG-SR/PG, if the DIP Switch Position 2 is set at ON (DIP Switch Enabled) and the Positions 3 to 8 are set to different functions from the settings of the backup data, the settings of the DIP Switch will be restored to the F3SG-SR/PG. When you want to change the settings of the F3SG-SR/PG to the backup data in the Intelligent Tap, change the DIP Switch Position 2 to OFF (DIP Switch Disabled) and then perform the Restoration again.
- If the DIP Switch Position 1 is set at ON (Lock) and settings in the Intelligent Tap corresponds with that in the sensor, restoration is not performed.
- If the Restoration is performed when the sensor configuration is different from the backup data, the information of the sensor that was restored will be newly recorded in the Intelligent Tap.

Follow the flowchart below to perform the Restoration.

 For detailed steps, refer to 3-10-3. *Applying Setting Saved in Intelligent Tap to Sensor Using Restoration.*

■ Flowchart for performing automatic Restoration

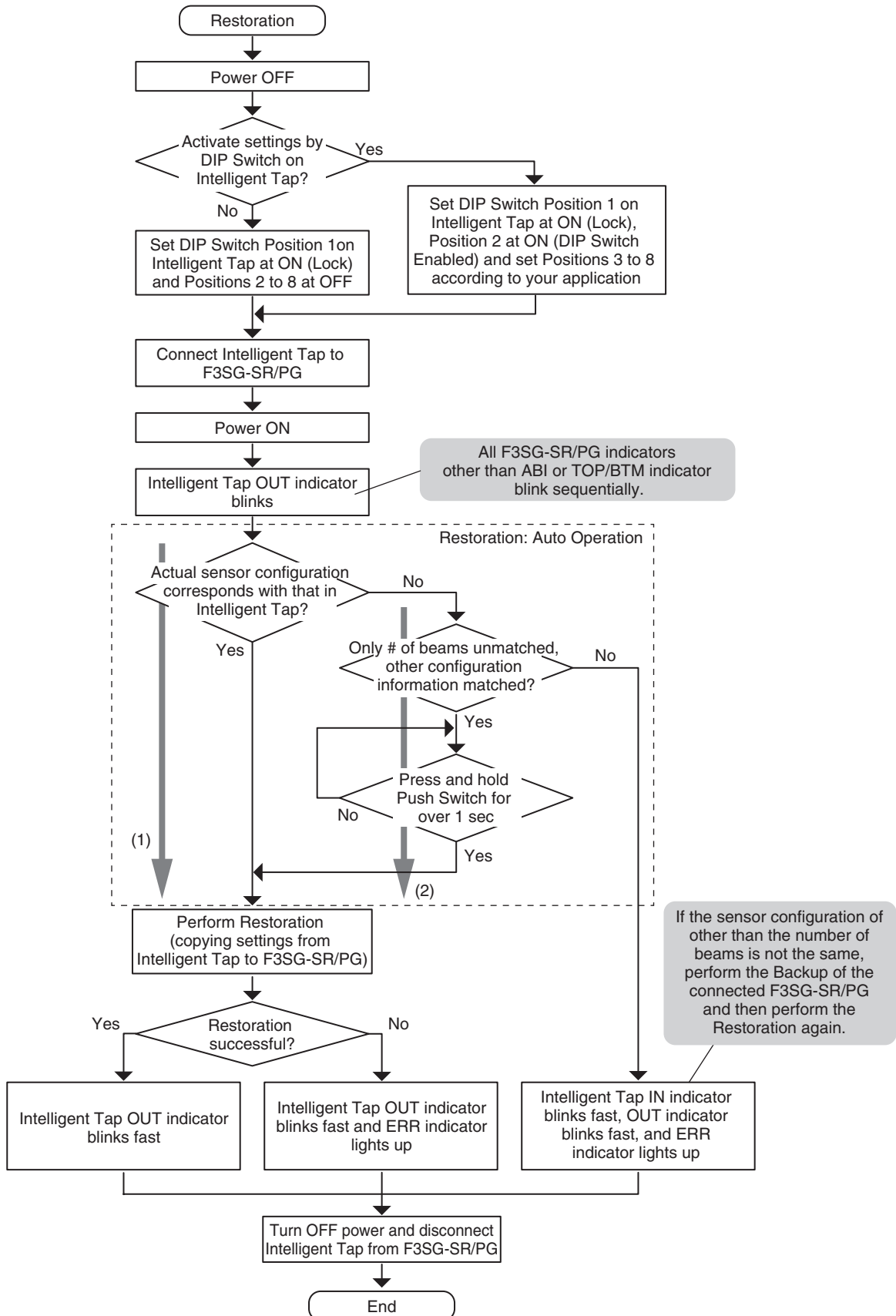

■ Flowchart for performing manual Restoration

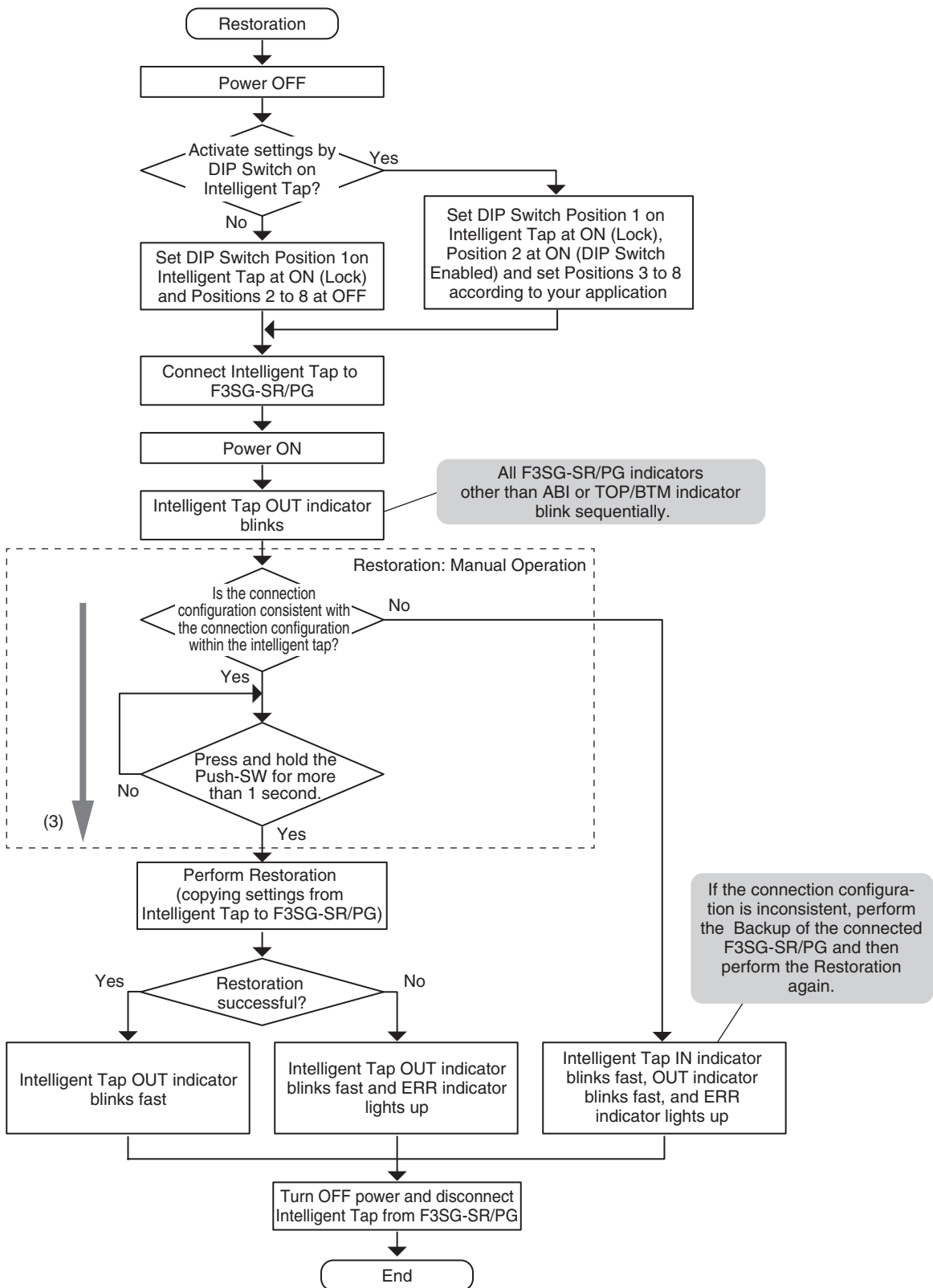

If the sensor configuration (model and cascading) in the Intelligent Tap corresponds with that of the actual one, the Restoration is automatically performed.(1)

If the sensor configurations differ only in the number of beams, you can forcibly perform the Restoration with the Push Switch.(2)

If the sensor configuration of other than the number of beams is not the same, perform the Backup of the connected F3SG-SR/PG and then perform the Restoration again.

When Restore is set to manual execution, Push-SW operation is required to execute the restore function, regardless of whether the sensor configuration within the Intelligent Tap matches the actual configuration or if only the number of optical axes differs. (3)



After the Restoration is performed, verify that the F3SG-SR/PG operates with intended settings before using the F3SG-SR/PG.

LED indication during Restoration

Function		Indicator			
Mode	State	IN (Yellow)	OUT (Green/Red)	IO-Link (Green)	ERR (Red)
Restoration	Transitioning modes	■	Green	--	■
	Waiting for Push Switch operation	■	Green		■
	Transferring data	■	Green		■
	Waiting for restart after Restoration	■	Green		■
	Waiting for restart due to unenforceable condition		Green		
	Waiting for restart due to communication error	■	Green		

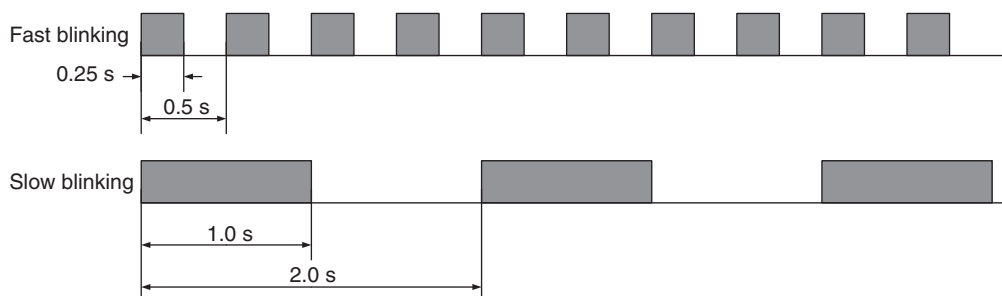

3-6-4. Various Usage of Backup and Restoration



This is an example of use when the Backup/Restoration function is enabled, with operation settings configured as Backup: Manual Operation, Restoration: Auto Operation.

For more details on configuration changes for these functions, please refer to 4-3-7. *Backup/Restoration*.

3-6-4-1. Plug and Work

If the F3SG-SR/PG with the Intelligent Tap installed causes a fault, its settings can be reconfigured only by replacing with a new F3SG-SR/PG of the same model and turning its power ON.

3-6-4-2. Copy and Paste of Sensor Settings

You can configure the same settings to multiple F3SG-SR/PG's by configuring one F3SG-SR/PG, performing the Backup to an Intelligent Tap, and restoring the settings to other F3SG-SR/PG's.

3-6-4-3. Changing F3SG-SR/PG Configuration to Connect to Intelligent Tap

If you want to change an F3SG-SR/PG's configuration to connect to an Intelligent Tap or if you want to connect the Intelligent Tap to another F3SG-SR/PG, perform the Backup of the settings of the newly connected F3SG-SR/PG first.

3-6-4-4. Changing F3SG-SR/PG's Settings with Intelligent Tap DIP Switch

To change the F3SG-SR/PG's settings only by setting the DIP Switch on the Intelligent Tap without using the SD Manager 3, follow the steps below.

1. If the light curtain is under operation while the Intelligent Tap is already connected

- (1) Make sure the power is OFF.
- (2) Make sure that the DIP Position 1 is set at ON (Lock), and set the Position 2 at ON (DIP Switch Enabled).
- (3) Configure other functions with the DIP Switch Positions 3 to 8.
- (4) After restart, restoration is performed.
- (5) When the Restoration is complete, the OUT indicator (green) blinks fast. Restart the F3SG-SR/PG.

2. To reflect the DIP Switch settings to an F3SG-SR/PG that has no Intelligent Tap connected

- (1) Connect an Intelligent Tap to the F3SG-SR/PG.
- (2) Turn the power ON. Refer to "3-6-2. *Performing Backup*" for the procedure of the Backup.
- (3) Perform the steps from (1) to (4) of the procedure No. 1 above.
- (4) After the Restoration is complete, turn the power OFF and disconnect the Intelligent Tap.

3-7. Teach-in (Fix Blanking / Floating Blanking)

⚠ WARNING

Make sure the Responsible Person test the operation of the F3SG-SR after setting with the Teach-in to verify that the F3SG-SR operates as intended. Unintended settings may cause a person to go undetected, resulting in serious injury.



F3SG-SRA	✓	F3SG-PGA-A		F3SG-PGA-C	
F3SG-SRB	✓	F3SG-PGA-L			

3-7-1. Setting Fixed Blanking by Teach-in

■ Overview

You can teach-in the settings of the Fixed Blanking by interrupting the target area of the Fixed Blanking. The Teach-in described in this chapter is performed with the Intelligent Tap connected to the F3SG-SR and using the Push Switch or the Muting Input A.

■ Teach-in steps

Perform the Teach-in of the Fixed Blanking based on the following steps.

- (1) Connect Intelligent Tap to F3SG-SR
- (2) Beam Alignment
- (3) DIP Switch Setting
- (4) Transition to Teach-in Mode
- (5) Teach-In and Check Processes
- (6) Restart

(1) Connect Intelligent Tap to F3SG-SR

Connect the Intelligent Tap to the F3SG-SR.

(2) Beam Alignment

Perform the beam alignment for the F3SG-SR . In the case of the Optical Synchronization, install the F3SG-SR so that the synchronization beams are clear. For detailed beam adjustment steps, see 5-3-4-5. *Mounting IP69K Model.*



CHECK!

Misalignment during the Teach-in may result in an unintended setting or a failure of the Teach-in.

(3) DIP Switch Setting

Before powering the F3SG-SR, set the DIP Switch of the intelligent tap as shown below, then power the F3SG-SR.

- Set channel 1 to ON (Lock)
- Set channel 2 to ON (DIP Switch Enabled)
- Set channel 6 to ON and channel 7 to OFF (Fixed Blanking Enabled)

The Intelligent Tap restores the settings configured by the DIP Switch, to the F3SG-SR. When the Restoration process is complete successfully, restart the F3SG-SR and check if the F3SG-SR operates normally.

Block the target Fixed Blanking zone by an object. Do not remove the object until the Step (5) is complete.

 Refer to 3-4. *LED Indicators on Intelligent Tap* for more information.

(4) Transition to Teach-in Mode

Under the factory default setting, pressing and holding the Push Switch (for 3 s or longer) makes the product transition to Teach-in mode.



When the F3SG-SR transitioned to Teach-in mode, the CFG indicator of the F3SG-SR receiver blinks. (The mode transition to Teach-in mode does not occur if the setting of the DIP Switch is configured as "Unlock", "DIP Switch Disabled" or "Fixed Blanking Disabled".)

 The factory default setting of the Teach-in Input is [Enable Teach-in by Push Switch]. When selecting [Enable Teach-in by Push Switch or wiring], select [Teach-in Input] – [Enable Teach-in by Push Switch or wiring] with the SD Manager 3 after the step (2), and then perform the Restoration.

CHECK! The [Enable Teach-in by Push Switch or wiring] function cannot be used in combination of some functions. Refer to 2-1. Combination of Functions for more information on combinations of functions.

 Refer to 4-3-2-3. *Teach-in Input* for more information on setting this function by the SD Manager 3.
Refer to 4-2-7-3. *Writing Configuration into Intelligent Tap* for more information on the Restoration by the SD Manager 3.

Indicator status of the F3SG-SR receiver under the Teach-in mode.

LED Indicator	Status
SEQ	OFF 
CFG	Blinking 
ABI *1	Area blocked by blocking object is illuminated in red

*1 If F3SG-SRA is used with the wired synchronization setting, the ABI indicator of the emitter for the area blocked by an object turns ON red.

(5) Teach-In and Check Processes

When it is ensured that the F3SG-SR is in the Teach-in mode, press the Push Switch (for within 1 s) or turn the muting input A ON (for within 1 s) to activate the scanning of the blocked area and automatically configure the setting related to the Fixed Blanking.*1

The F3SG-SR judges if the setting is valid or not.

If the setting is invalid*2, SEQ indicator of the receiver blinks. In this case, try the steps again from (4).

*1 The Fixed Blanking zone is configured to include one additional beam outside the actually blocked beams. Two beams on both ends are configured as allowable beams.

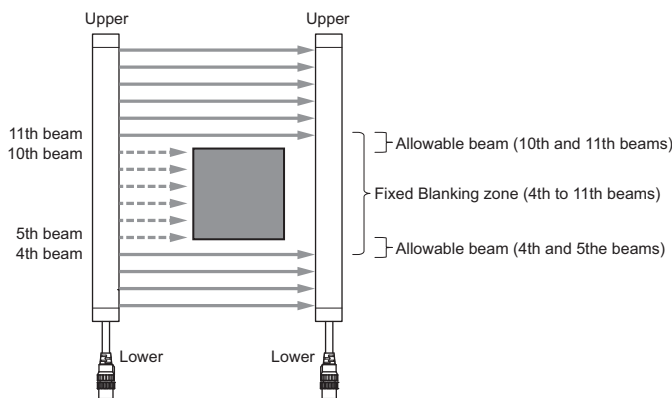

*2 If the setting value is not an allowable one, the setting is invalid. The following cases are judged as invalid.

- All beams have been configured as a Fixed Blanking zone (including allowable beams).(Fig. 1)
- All beams except the beams at both ends have been configured as a Fixed Blanking zone. (Fig. 2)
- End beams (synchronization beams) have been configured as a Fixed Blanking zone at the same time. (Primary sensor in Optical Synchronization only) (Fig. 3)
- If beams are not blocked before transition to the Teaching Mode.
- If the gap between blocking objects is not 3 beams or wider on teaching of multiple fixed blanking areas.(Fig. 4)
- Four or more areas have been configured as Fixed Blanking zones for one channel.

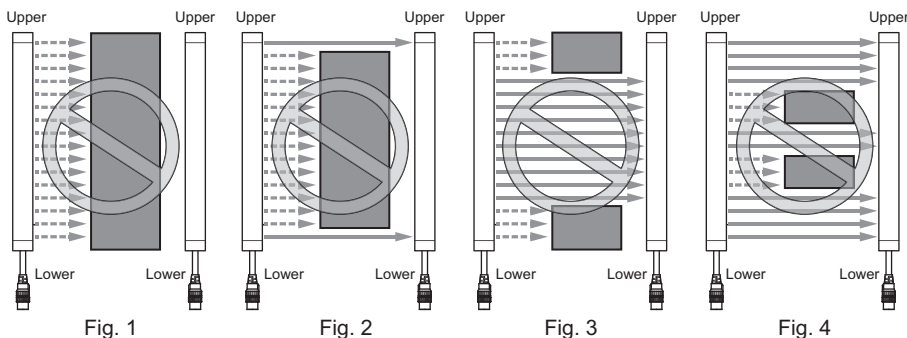

Indicator status of the F3SG-SR receiver when Teach-in setting is valid or invalid

Teach-in setting is valid		Teach-in setting is invalid	
LED Indicator	Status	LED Indicator	Status
SEQ	OFF	SEQ	Blinking
CFG	illuminated	CFG	Blinking
ABI *1	Area blocked by blocking object is illuminated in red	ABI *1	Area blocked by blocking object is illuminated in red

*1 If F3SG-SRA is used with the wired synchronization setting, the ABI indicator of the emitter for the area blocked by an object turns ON red.

(6) Restart

<When operating the F3SG-SR with the Intelligent Tap not connected>

When completing the Teach-in setting, power off the F3SG-SR and remove the Intelligent Tap. Then restart the F3SG-SR.

<When operating the F3SG-SR with the Intelligent Tap connected>

When completing the Teach-in setting, power off the F3SG-SR and set the DIP Switch Position 1 at OFF (Unlock). Then restart the F3SG-SR.

There are two ways to restart.

- Power cycling
- Pressing and holding reset switch (for 1 s or longer): Set the DIP Switch Position 1 at OFF (Unlock). (If restarting the F3SG-SR with the DIP Switch Position 1 set at ON (Lock), the configured zone will be invalid. In this case, try the steps again from (4).)

After the restarting, the F3SG-SR waits for the Backup process of the settings. Perform the Backup process. After the Backup process is complete, the power off the F3SG-SR and set the DIP Switch Position 1 at ON (Lock). Check if the DIP Switch Positions 2 to 8 and other settings are configured as intended, and then restart the F3SG-SR. After the F3SG-SR is restarted, the check if the Fixed Blanking zone and other settings are properly configured.



Refer to 3-6-2. *Performing Backup* for more information on the Backup procedure.

Others

- When the Teach-in is performed with the all Fixed Blanking zone being unblocked, the Fixed Blanking is configured as Disabled. Teach-in is available under cascade connection as well. In such a case, use the Push Switch on the Intelligent Tap or the muting input A to perform Teach-in with the similar steps.
- When the F3SG-SR is in the cascade connection, the Teach-in setting is performed for each channel independently. This allows different F3SG-SR's to have different Teach-in settings depending on the position or size of the blocking object. For example, when the secondary sensor (Channel 2) of the F3SG-SR is blocked, that secondary sensor (Channel 2) only has the Fixed Blanking setting.

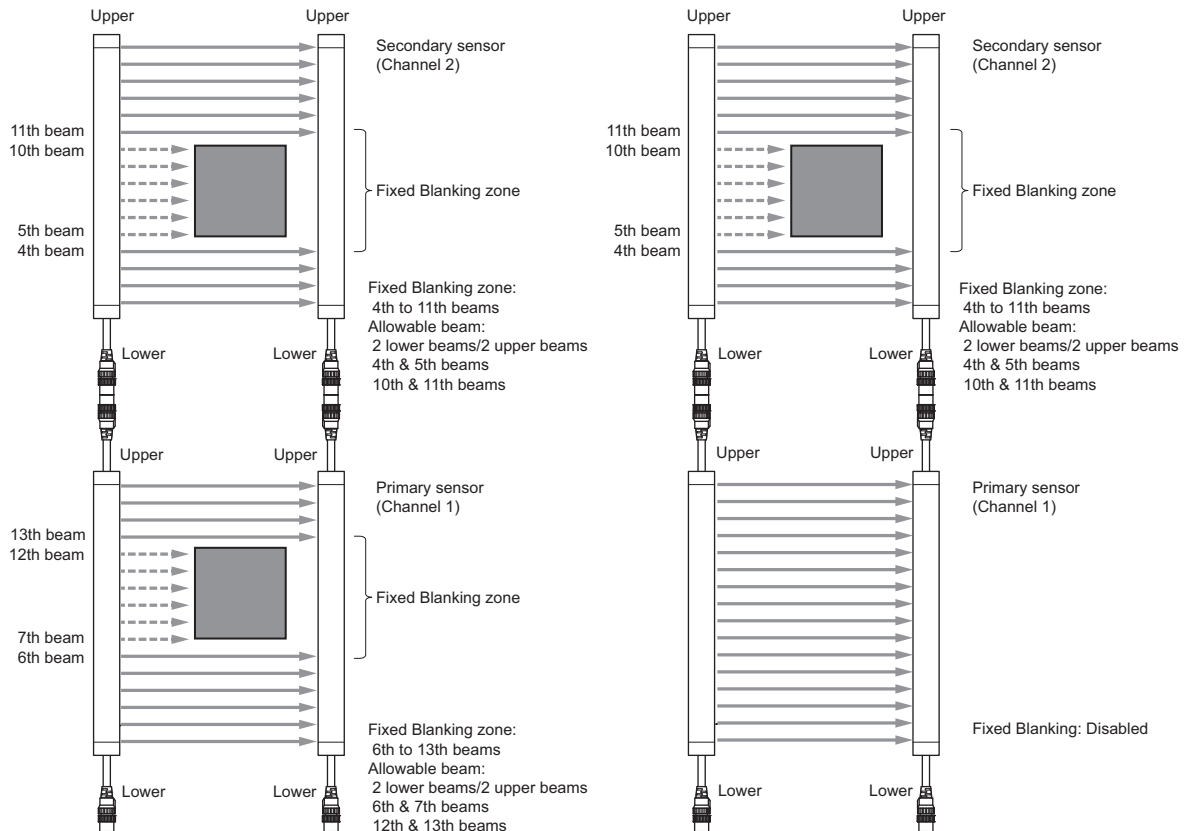

- The Teach-in result for Fixed Blanking and Floating Blanking cannot be saved together. When the Teach-in is performed for Floating Blanking, the result of the Teach-in for Fixed Blanking is cleared.

3-7-2. Setting Floating Blanking by Teach-in

■ Overview

You can teach-in the settings of the Floating Blanking by interrupting with an object to monitor by the Floating Blanking. The Teach-in described in this chapter is performed with the Intelligent Tap connected to the F3SG-SR and using the Push Switch or the Muting Input A.

■ Teach-in steps

Perform the Teach-in of the Floating Blanking based on the following steps.

- (1) Connect Intelligent Tap to F3SG-SR
- (2) Beam Alignment
- (3) DIP Switch Setting
- (4) Transition to Teach-in Mode
- (5) Result Check Process
- (6) Restart

(1) Connect Intelligent Tap to F3SG-SR

Connect the Intelligent Tap to the F3SG-SR.

(2) Beam Alignment

Perform the beam alignment for the F3SG-SR. In the case of the Optical Synchronization, install the F3SG-SR so that the synchronization beams are clear.

For detailed beam adjustment steps, see 5-3-4-5. *Mounting IP69K Model*.



CHECK!

Misalignment during the Teach-in may result in an unintended setting or a failure of the Teach-in.



CHECK!

The factory default setting of the Teach-in Input is [Push Switch]. When selecting [Push Switch or external wiring], select [Teach-in Input] – [Push Switch or external wiring] with the SD Manager 3 after the step (2), and then perform the Restoration.



Refer to 4-3-2-3. *Teach-in Input* for more information on setting this function by the SD Manager 3.

Refer to 4-2-7-3. *Writing Configuration into Intelligent Tap* for more information on the Restoration by the SD Manager 3.

(3) DIP Switch Setting

Before powering F3SG-SR, set the DIP Switch of the intelligent tap as shown below, then power the F3SG-SR.

- Set channel 1 to ON (Lock)
- Set channel 2 to ON (DIP Switch Enabled)
- Set channel 6 to OFF and channel 7 to ON (Floating Blanking Enabled)

The Intelligent Tap restores the settings configured by the DIP Switch, to the F3SG-SR. When the Restoration process is complete is completed successfully, restart the F3SG-SR and check if the F3SG-SR operates normally.

Block the target Floating Blanking zone by an object. Do not remove the object until the Step (5) is complete.



CHECK!

The object must be no smaller than the object resolution.



Refer to 3-4. *LED Indicators on Intelligent Tap* for more information.

(4) Transition to Teach-in Mode

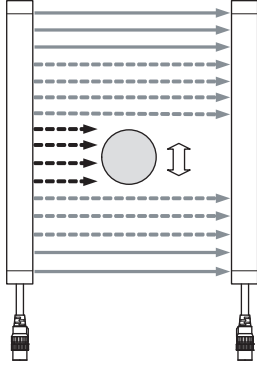

Press and hold the Push Switch (for 3 s or longer) or turn the muting input A ON (for 3 s or longer) to make the F3SG-SR transition to Teach-in mode. Upon transition the scan is started for the blocked location. Move the blocking object in parallel with the F3SG-SR.

The object of the size of at least 1 beam must be moved. Failure to do so will result in a failure of allowable beam setting.



When transitioned to Teach-in mode, the CFG indicator of the F3SG-SR receiver blinks. (The mode transition to Teach-in mode does not occur if the setting of the DIP Switch is configured as "Unlock", "DIP Switch Disabled" or "Floating Blanking Disabled".)

Indicator status of the F3SG-SR receiver in Teach-in mode.

LED Indicator	Status
SEQ	OFF 
CFG	Blinking 
ABI *1	Area blocked by blocking object is illuminated in red

*1 If F3SG-SRA is used with the wired synchronization setting, the ABI indicator of the emitter for the area blocked by an object turns ON red.





(5) Result Check Process

Press the Push Switch (for within 1 s) or turn the muting input A ON (for within 1 s) automatically configures the Floating Blanking setting based on the scan result.*1

The determined setting is processed for valid/invalid judgment process in the sensor.

If the setting is invalid*2, SEQ indicator of the receiver blinks. In this case, try the steps again from (4).

Indicator status of the F3SG-SR receiver when Teach-in setting is valid or invalid

Teach-in setting is valid		Teach-in setting is invalid	
LED Indicator	Status	LED Indicator	Status
SEQ	OFF 	SEQ	Blinking 
CFG	illuminated 	CFG	Blinking 
ABI *3	Area blocked by blocking object is illuminated in red	ABI *3	Area blocked by blocking object is illuminated in red

*1 The number of blanked beams is configured with the maximum number of blocked beams in the Teach-in process (steps (4) to (5)). Allowable beams are configured with (Maximum blocked beams - Minimum blocked beams) in the teach-in process. The blanking monitoring function is configured as lockout.

*2 If the setting value is not an allowable one, the setting is invalid. The following cases are judged as invalid.

- The number of blanked beams is configured as nine (9) or more.
- The number of allowable beams is configured as three (3) or more.
- The number of blanked beams is the same as that of sensor beams.
- Number of allowable beams \geq Number of blanked beams
- Teach-in is started when an object does not exist.
- Beam-blocked state is detected discontinuously in the Teach-in process.
- The blocking object is removed until the steps (4) to (5) are completed.

*3 If F3SG-SRA is used with the wired synchronization setting, the ABI indicator of the emitter for the area blocked by an object turns ON red.

(6) Restart

<When operating the F3SG-SR with the Intelligent Tap not connected>

When completing the Teach-in setting, power off the F3SG-SR and remove the Intelligent Tap. Then restart the F3SG-SR.

<When operating the F3SG-SR with the Intelligent Tap connected>

When completing the Teach-in setting, power off the F3SG-SR and set the DIP Switch Position 1 at OFF (Unlock). Then restart the F3SG-SR.

There are two ways to restart.

- Power cycling
- Pressing and holding reset switch (for 1 s or longer): Set the DIP Switch Position 1 at OFF (Unlock). (If restarting the F3SG-SR with the DIP Switch Position 1 set at ON (Lock), the configured zone will be invalid. In this case, try the steps again from (4).)

After the restarting, the F3SG-SR waits for the Backup process of the settings. Perform the Backup process. After the Backup process is complete, the power off the F3SG-SR and set the DIP Switch Position 1 at ON (Lock). Check if the DIP Switch Positions 2 to 8 and other settings are configured as intended, and then restart the F3SG-SR. After the F3SG-SR is restarted, the check if the Floating Blanking zone and other settings are properly configured.



Refer to 3-6-2. *Performing Backup* for more information on the Backup procedure.

■ Others

- Be sure to perform the Teach-in setting of the Floating Blanking while moving the interrupting object. If teach-in is performed with all areas receiving light, the Floating Blanking is configured as invalid.
- The Teach-in is available under cascade connection as well.
- If The Teach-in is performed with a cascade connection, Teach-in setting is configured for each channel independently. If sizes of blocking objects are different, settings are configured differently for sensors as well. For example, if only the secondary sensor (Channel 2) of the F3SG-SR is blocked, the blanking setting is configured for the secondary sensor (Channel 2) only. Other sensors than the Channel 2 work as normal detection zone.

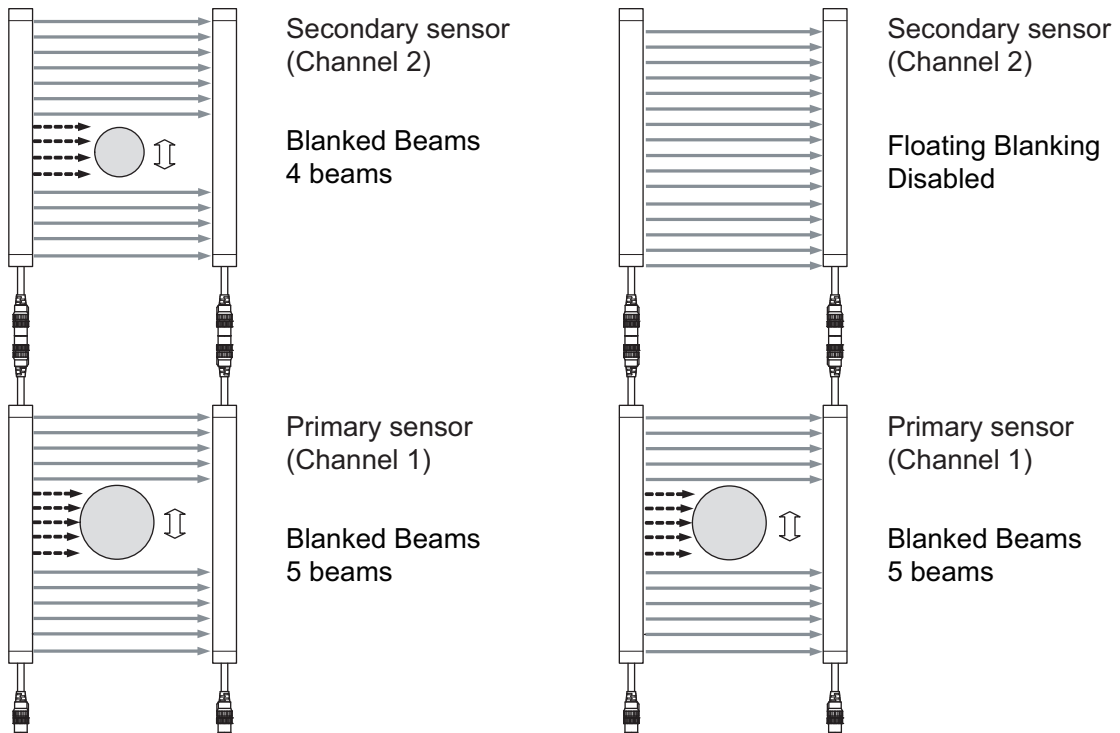

3-8. Connection to SD Manager 3

Follow the steps below to connect to the SD Manager 3.

■ To edit backup/restoration data in the Intelligent Tap

1. Connect the Intelligent Tap and computer via a USB cable. Make sure that the DIP Switch Position 1 is set at ON (Lock) and DIP Switch Position 2 at OFF (DIP Switch Disabled). The Intelligent Tap can run by USB power supply with no external power supply connected.
2. Load the backup/restoration data from the Intelligent Tap, then edit the data with the SD Manager 3, and write the data to the Intelligent Tap.
3. When the write is complete, unplug the USB cable from the Intelligent Tap.



CHECK!

- Make sure that the DIP Switch Position 1 is set at ON (Lock) before connecting to F3SG-SR/PG and turning on power. If the DIP Switch Position 1 is set at OFF (Unlock), the Backup is performed and the edited setup data may be overwritten by the sensor setup data in the connected unit.
- Even when the DIP Switch Position 1 is set at ON (Lock), you can edit the configuration by the SD Manager 3.

■ To edit F3SG-SR/PG setup data

1. Connect the Intelligent Tap to the F3SG-SR/PG and set the F3SG-SR/PG to the state where the backup has been performed. Make sure that the DIP Switch Position 1 is set at ON (Lock) and DIP Switch Position 2 at OFF (DIP Switch Disabled).
2. Connect the Intelligent Tap and computer via a USB cable with the F3SG-SR/PG and the Intelligent Tap powered.
3. Load the setup parameters, then edit and write them. The setup parameters are written to both F3SG-SR/PG and Intelligent Tap.
4. Before restarting, make sure that the DIP Switch Position 1 is set at ON (Lock) and DIP Switch Position 2 at OFF (DIP Switch Disabled), or that the Intelligent Tap is unplugged from the F3SG-SR/PG.



CHECK!

- If the DIP Switch Position 2 is set at ON (DIP Switch Enabled) and if the restoration is performed, settings of interlock, blanking, and Operating Range Selection will be overwritten by the settings of the DIP switch.

3-9. IO-Link

⚠ WARNING

Do not use the output signal of the IO-Link output for safety applications. Failure to do so may result in serious injury when the F3SG-SR/PG fails.



3-9-1. Functional Description

The Intelligent Tap, as an IO-Link device, can send information of sensor's setup status and monitoring via the IO-Link master.

Download an IO-Link Device Description file (IODD file) from the website.



For details, refer to your local Omron website.

3-9-2. Communication Specifications

Model	F39-SGIT-IL3
IO-Link version	Version 1.1
Transmission rate	COM3 (230.4 kbps)
Minimum cycle time	22 ms
Process data length	4 bytes
On-request data length	32 bytes
Process data endian	Big endian *1
Message sequence type	TYPE_2_V
Vendor ID	612 (0x0264)
Device ID	262145 (0x040001)

*1. The endian is big endian even if the service data is 2 bytes or larger.

3-9-3. Process Data

Byte 0 (PD0)	Bit7	Bit6	Bit5	Bit4	Bit3	Bit2	Bit1	Bit0	
	Offset31	Offset30	Offset29	Offset28	Offset27	Offset26	Offset25	Offset24	
Power supply voltage (Upper 8bit)									
Byte 1 (PD1)	Bit7	Bit6	Bit5	Bit4	Bit3	Bit2	Bit1	Bit0	
	Offset23	Offset22	Offset21	Offset20	Offset19	Offset18	Offset17	Offset16	
Power supply voltage (Lower 8bit)									
Byte 2 (PD2)	Bit7	Bit6	Bit5	Bit4	Bit3	Bit2	Bit1	Bit0	
	Offset15	Offset14	Offset13	Offset12	Offset11	Offset10	Offset9	Offset8	
	Reserved (0)	Instantaneous Block Detection Information (Channel 3)	Instantaneous Block Detection Information (Channel 2)	Instantaneous Block Detection Information (Channel 1)	Light level diagnosis information (Channel 3)	Light level diagnosis information (Channel 2)	Light level diagnosis information (Channel 1)	Sequence error information	

Byte 3 (PD3)	Bit7	Bit6	Bit5	Bit4	Bit3	Bit2	Bit1	Bit0
	Offset7	Offset6	Offset5	Offset4	Offset3	Offset2	Offset1	Offset0
	Sensor or Intelligent Tap Lockout information	Intelligent Tap Lockout information	Reserved (0)	RESET/ EDM/ Override input status	Mute B input status	Mute A input status	Auxiliary output status	Safety output status

The table below lists the data size and descriptions of the process data items.

Name	Data size	Description
Power supply voltage	16 bits	Power supply voltage value for Receiver being supplied. (mV)
Sequence error information	1 bit	1: Under muting sequence error state or interlock sequence error state 0: The others
Light level diagnosis information (Channel 1)	1 bit	1: When one segment system of the F3SG-SR/PG or the primary sensor is unblocked and light intensity is within a range from 100% to 170% (factory default setting*1) of ON-threshold for 10 s or longer. *2 0: The others
Light level diagnosis information (Channel 2)	1 bit	1: When the 1st secondary sensor in cascade connection is unblocked and light intensity is within a range from 100% to 170% (factory default setting*1) of ON-threshold for 10 s or longer. *2 0: The others
Light level diagnosis information (Channel 3)	1 bit	1: When the 2nd secondary sensor in cascade connection is unblocked and light intensity is within a range from 100% to 170% (factory default setting*1) of ON-threshold for 10 s or longer. *2 0: The others
Instantaneous Block Detection Information (Channel 1)	1 bit	1: When the Sensor system of one segment system of the F3SG-SR/PG or the primary sensor stops accidentally due to instantaneous blocking. 0: The others
Instantaneous Block Detection Information (Channel 2)	1 bit	1: When the Sensor system of the 1st secondary sensor in cascade connection stops accidentally due to instantaneous blocking. 0: The others
Instantaneous Block Detection Information (Channel 3)	1 bit	1: When the Sensor system of the 2nd secondary sensor in cascade connection stops accidentally due to instantaneous blocking. 0: The others
Safety output status	1 bit	1: ON, 0: OFF
Auxiliary output status	1 bit	1: ON, 0: OFF
Mute A input status	1 bit	1: ON, 0: OFF
Mute B input status	1 bit	1: ON, 0: OFF
RESET/EDM/Override input status	1 bit	1: ON, 0: OFF
Intelligent Tap Lockout information	1 bit	1: Intelligent Tap is in LOCKOUT state 0: The others
Sensor or Intelligent Tap lockout information	1 bit	1: Sensor or Intelligent Tap is in LOCKOUT state 0: The others
Reserved	4 bytes	0

*1. It is necessary to change the value in the setting of [Stable Light Threshold Adjustment] of the SD Manager 3.

Refer to 2-24. *Stable Light Threshold Adjustment* and 4-3-5-2. *Stable Light Threshold Adjustment* for more information on the stable light threshold value.

*2. After the bit becomes 1 then normal blocking occurs, it becomes 0.

3-9-4. Service Data

Index	Sub-Index	Name	R/W	Length	Setting contents
16	0	Vendor Name	R	64 bytes	"OMRON Corporation" (17bytes)
17	0	Vendor Text	R	64 bytes	"OMRON Corporation" (17bytes)
18	0	Product Name	R	64 bytes	"F39-SGIT-IL3" (30bytes)
20	0	Product text	R	64 bytes	"Intelligent Tap" (15bytes)
21	0	Serial Number	R	10 bytes	Intelligent Tap's Serial Number(8 characters and 2 spaces)
22	0	Hardware Version	R	5 bytes	Intelligent Tap's Hardware Version XX.XX (5characters)
23	0	Firmware Version	R	5 bytes	Intelligent Tap's Firmware Version XX.XX (5characters)
24	0	Application Specific Tag	R/W	32 bytes	initial value: ***** (32 asterisks)
40	0	Process- DataInput	R	4 bytes	16-31bit: Power supply
					15 bit: Reserved (0)
					14 bit: Instantaneous Block Detection Information (Channel 3)
					13 bit: Instantaneous Block Detection Information (Channel 2)
					12 bit: Instantaneous Block Detection Information (Channel 1)
					11 bit: Light level diagnosis information (Channel 3)
					10 bit: Light level diagnosis information (Channel 2)
					9 bit: Light level diagnosis information (Channel 1)
					8 bit: Sequence error information
					7 bit: Sensor or Intelligent Tap lockout information
					6 bit: Intelligent Tap Lockout Information
					5bit: Reserved (0)
					4 bit: Reset/EDM/Override input status
					3 bit: Mute B input status
					2 bit: Mute A input status
1 bit: Auxiliary output status					
0 bit: Safety output status					
64 (Primary sensor Receiver)	1	Supplier	R	17 bytes	OMRON Corporation 0 if the sensor is not connected
	2	Product name	R	30 bytes	F3SG-XXXX 0 if the sensor is not connected
	3	Serial Number	R	10 bytes	Serial Number 0 if the sensor is not connected
	4	Hardware Version	R	5 bytes	Hardware Version XX.XX (5characters) 0 if the sensor is not connected
	5	Firmware Version	R	5 bytes	Firmware Version XX.XX (5characters) 0 if the sensor is not connected
65 (SLC's 2nd Receiver)	1	Supplier	R	17 bytes	OMRON Corporation 0 if the sensor is not connected
	2	Product name	R	30 bytes	F3SG-XXXX 0 if the sensor is not connected
	3	Serial Number	R	10 bytes	Serial Number 0 if the sensor is not connected
	4	Product version (Hardware)	R	5 bytes	Hardware Version XX.XX (5characters) 0 if the sensor is not connected
	5	Product version (Firmware)	R	5 bytes	Firmware Version XX.XX (5characters) 0 if the sensor is not connected

Index	Sub-Index	Name	R/W	Length	Setting contents	
66 (Secondary sensor 2 Receiver)	1	Supplier	R	17 bytes	OMRON Corporation	
					0 if the sensor is not connected	
	2	Product name	R	30 bytes	F3SG-XXXX	
					0 if the sensor is not connected	
	3	Serial Number	R	10 bytes	Serial Number	
					0 if the sensor is not connected	
	4	Hardware Version	R	5 bytes	Hardware Version XX.XX (5characters)	
					0 if the sensor is not connected	
	5	Firmware Version	R	5 bytes	Firmware Version XX.XX (5characters)	
					0 if the sensor is not connected	
	67 (Primary sensor Emitter)	1	Supplier	R	17 bytes	OMRON Corporation
						0 if the sensor is not connected
		2	Product name	R	30 bytes	F3SG-XXXX
						0 if the sensor is not connected
		3	Serial Number	R	10 bytes	Serial Number
0 if the sensor is not connected						
4		Hardware Version	R	5 bytes	Hardware Version XX.XX (5characters)	
					0 if the sensor is not connected	
5		Firmware Version	R	5 bytes	Firmware Version XX.XX (5characters)	
					0 if the sensor is not connected	
68 (Secondary sensor 1 Emitter)		1	Supplier	R	17 bytes	OMRON Corporation
						0 if the sensor is not connected
		2	Product name	R	30 bytes	F3SG-XXXX
						0 if the sensor is not connected
		3	Serial Number	R	10 bytes	Serial Number
	0 if the sensor is not connected					
	4	Hardware Version	R	5 bytes	Hardware Version XX.XX (5characters)	
					0 if the sensor is not connected	
	5	Firmware Version	R	5 bytes	Firmware Version XX.XX (5characters)	
					0 if the sensor is not connected	
	69 (Secondary sensor 2 Emitter)	1	Supplier	R	17 bytes	OMRON Corporation
						0 if the sensor is not connected
		2	Product name	R	30 bytes	F3SG-XXXX
						0 if the sensor is not connected
		3	Serial Number	R	10 bytes	Serial Number
0 if the sensor is not connected						
4		Hardware Version	R	5 bytes	Hardware Version XX.XX (5characters)	
					0 if the sensor is not connected	
5		Firmware Version	R	5 bytes	Firmware Version XX.XX (5characters)	
					0 if the sensor is not connected	

Index	Sub-Index	Name	R/W	Length	Setting contents
70	1	Synchronization method setting	R	1 byte	0: Optical sync. Scan code A
					1: Optical sync. Scan code B
					2: Wired sync.
					3: Reserved.
	2	External device monitor setting	R	1 byte	1: Enable , 0: Disable
	3	Interlock / Pre-Reset / PSDI setting	R	1 byte	0: Auto reset (both start and re-start interlock are disabled)
					1: Start interlock is enabled.
					2: Re-start interlock is enabled.
					3: Manual reset (both start and re-start interlock are enabled)
					4: Pre-Reset is enabled.
					5: PSDI single break
					6: PSDI double break
The others: Reserved.					
4	Blanking setting	R	1 byte	1: One of Fixed Blanking or Floating Blanking and Warning zone setting is enabled. 0: Fixed Blanking, Floating Blanking and Warning zone setting are disabled.	
5	PNP / NPN setting	R	1 byte	1: PNP setting 0: NPN setting	
6	Dip switch setting	R	1 byte	1: Enable 0: Disable (setting is done by Tool)	
7	Muting status	R	1 byte	1: Under the MUTING state 0: The other	
8	Override status	R	1 byte	1: Under the OVERRIDE state 0: The other	
9	Muting sequence error status	R	1 byte	1: Muting setting is active and sequence error occurs. 0: The other	
10	Safety output status	R	1 byte	1: ON 0: OFF	
11	Blanking bream unblocked information	R	1 byte	1: When Fixed-Blanking or Floating Blanking beams are unblocked 0: The other	
12	Push switch status	R	1 byte	1: ON 0: OFF	
71 (Primary sensor Receiver)	0	Receiving light level	R	232 bytes	1byte x 232 beams The incident light level data of each beam is output in 0 to 255 (8 bits) every beam (1 byte). *1 0 if the sensor is not connected or no light is received
72 (Secondary sensor 1 Receiver)	0	Receiving light level	R	232 bytes	1byte x 232 beams The incident light level data of each beam is output in 0 to 255 (8 bits) every beam (1 byte). *1 0 if the sensor is not connected or no light is received
73 (Secondary sensor 2 Receiver)	0	Receiving light level	R	232 bytes	1byte x 232 beams The incident light level data of each beam is output in 0 to 255 (8 bits) every beam (1 byte). *1 0 if the sensor is not connected or no light is received
80	0	Error code of Intelligent Tap	R	48 bytes (8 bytes x 6)	Error code data is output in 8 bytes. In order from upper to lower 1 byte: Error code 4 bytes: Power-ON Time (1 count every 15 minutes) 3 bytes: Data for inquiry* Latest 6 records can be got. * Please use the data for your inquiry.

*1. Defining the receiving light intensity level that turns ON the control output as 100%, the output is 22. Therefore, if the level is 170% and 90%, the output is 38 and 20, respectively.

Index	Sub-Index	Name	R/W	Length	Setting contents
81 (Primary sensor Receiver)	0	Error code	R	32 bytes (8 bytes x 4)	Error code data is output in 8 bytes. In order from upper to lower 1 byte: Error code 4 bytes: Power-ON Time (1 count every 15 minutes) 3 bytes: Data for inquiry* Latest 4 records can be got. * Please use the data for your inquiry. 0 if the sensor is not connected
82 (Secondary sensor 1 Receiver)	0	Error code	R	32 bytes (8 bytes x 4)	Error code data is output in 8 bytes. In order from upper to lower 1 byte: Error code 4 bytes: Power-ON Time (1 count every 15 minutes) 3 bytes: Data for inquiry* Latest 4 records can be got. * Please use the data for your inquiry. 0 if the sensor is not connected
83 (Secondary sensor 2 Receiver)	0	Error code	R	32 bytes (8 bytes x 4)	Error code data is output in 8 bytes. In order from upper to lower 1 byte: Error code 4 bytes: Power-ON Time (1 count every 15 minutes) 3 bytes: Data for inquiry* Latest 4 records can be got. * Please use the data for your inquiry. 0 if the sensor is not connected
84 (Primary sensor Emitter)	0	Error code	R	32 bytes (8 bytes x 4)	Error code data is output in 8 bytes. In order from upper to lower 1 byte: Error code 4 bytes: Power-ON Time (1 count every 15 minutes) 3 bytes: Data for inquiry* Latest 4 records can be got. * Please use the data for your inquiry. 0 if the sensor is not connected
85 (Secondary sensor 1 Emitter)	0	Error code	R	32 bytes (8 bytes x 4)	Error code data is output in 8 bytes. In order from upper to lower 1 byte: Error code 4 bytes: Power-ON Time (1 count every 15 minutes) 3 bytes: Data for inquiry* Latest 4 records can be got. * Please use the data for your inquiry. 0 if the sensor is not connected
86 (Secondary sensor 2 Emitter)	0	Error code	R	32 bytes (8 bytes x 4)	Error code data is output in 8 bytes. In order from upper to lower 1 byte: Error code 4 bytes: Power-ON Time (1 count every 15 minutes) 3 bytes: Data for inquiry* Latest 4 records can be got. * Please use the data for your inquiry. 0 if the sensor is not connected
160	0	Operation Time Operation time period	R	4 bytes	The Power-ON Time of Intelligent Tap (1 count every 1 hours)



Refer to 8-1-2-2. *Troubleshooting* for more information on error codes and error descriptions.

3-10. Intelligent Tap Application Example

 This is an example of use when the Backup/Restoration function is enabled, with operation settings configured as Backup: Manual Operation, Restoration: Auto Operation.
For more details on configuration changes for these functions, please refer to 4-3-7. *Backup/Restoration*.

3-10-1. Setting F3SG-SR/PG with DIP Switch

You can change the F3SG-SR/PG settings using DIP-SW of the intelligent tap.

■ Work steps

1. If power of the intelligent tap or F3SG-SR/PG is ON, turn it OFF.
2. Use a Phillips screwdriver to remove the cover of the intelligent tap.

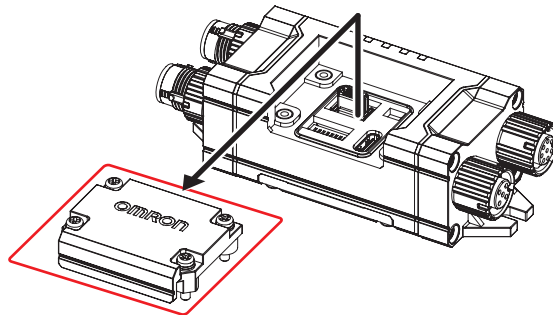

3. Set the DIP-SW channels 1 and 2 ON.

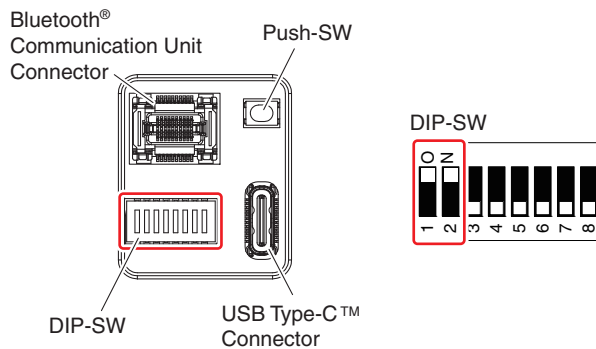

4. Set the DIP-SW channels 3 to 8 ON or OFF as needed.

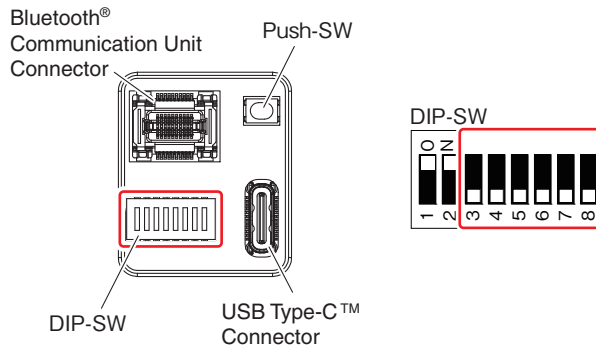

 For details of the channels, refer to 3-5. *DIP Switch on Intelligent Tap*.

5. If the intelligent tap is not connected yet, connect it to F3SG-SR/PG.

Make sure that the configuration is as shown below in the right.

F3SG-SR AND F3SG-PG-A/-L
Wiring for Optical Synchronization without Intelligent Tap

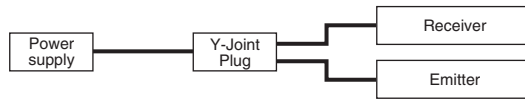

F3SG-SR AND F3SG-PG-A/-L
Wiring for Wired Synchronization with Intelligent Tap

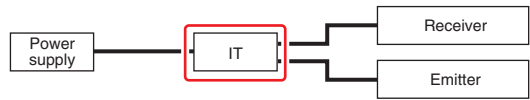

F3SG-SR AND F3SG-PG-A/-L
Wiring for Wired/Optical Synchronization without Intelligent Tap



F3SG-SR AND F3SG-PG-A/-L
Wiring for Optical Synchronization with Intelligent Tap

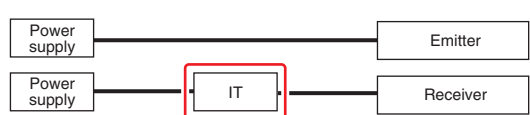

F3SG-PG-C
Wiring for Optical Synchronization without Intelligent Tap



F3SG-PG-C
Wiring for Wired Synchronization with Intelligent Tap



IT : Intelligent Tap

6. Turn on power of the intelligent tap and F3SG-SR/PG.

Restoration is automatically performed.

7. Check the indicators on the intelligent tap if restoration is complete.

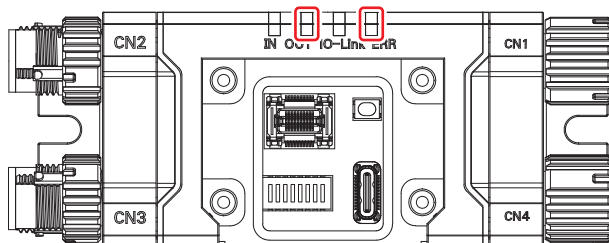

<Status of indicators at normal end>
OUT :Flashing green at 0.5 second cycle
(quick flashing)
ERR :Not lit

If the indicators are not proper, turn off power of the intelligent tap, make sure that the wiring is proper, and go back to step 3. to perform the steps again.

8. Turn off power of the intelligent tap and F3SG-SR/PG, then turn on power of them.

The settings are not enabled unless the intelligent tap and F3SG-SR/PG are restarted.



CHECK!

9. Check that F3SG-SR/PG runs as intended.

If it does not, turn off power of the intelligent tap, make sure that the wiring is proper, and go back to step 3. to perform the steps again.

10. Turn off power of the intelligent tap and F3SG-SR/PG.

- To finish the maintenance task and start normal operation of the facility, perform the followings.

1. Use a Phillips screwdriver to attach the cover of the intelligent tap.
(Recommended tightening torque: 0.35N•m)

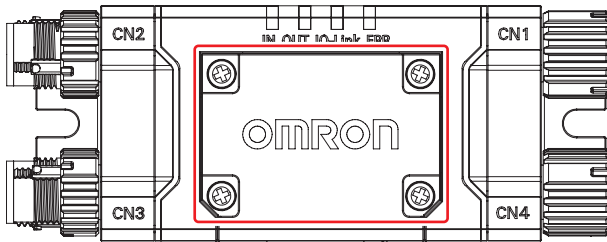

2. If a cable is not attached to CN3, use the torque wrench XY2F-0004 to attach the accessory waterproof cover (for plug).
(Recommended tightening torque for waterproof cover (for plug): 0.39 to 0.49N•m)
3. If a cable is not attached to CN4, attach the accessory waterproof cover (for socket).

3-10-2. Saving Sensor Setting to Intelligent Tap Using Backup Function

You can use the backup function to save to the intelligent tap the same settings as setup information stored in F3SG-SR/PG. To apply the saved setting to another F3SG-SR/PG, refer to 3-10-3. *Applying Setting Saved in Intelligent Tap to Sensor Using Restoration.*

- Work steps

1. If power of the intelligent tap or F3SG-SR/PG is ON, turn it OFF.
2. Use a Phillips screwdriver to remove the cover of the intelligent tap.

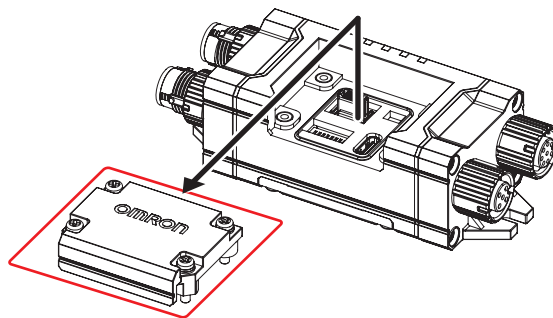

3. Set the DIP-SW channels 1 to 8 OFF.

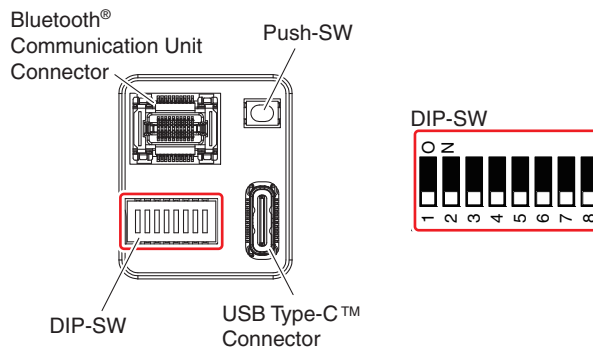

4. If the intelligent tap is not connected yet, connect it to F3SG-SR/PG. Refer to the chart in 3-10-1. *Setting F3SG-SR/PG with DIP Switch, ■Step 5.* to make sure that the system has the configuration with intelligent tap.
5. Turn on power of the intelligent tap and F3SG-SR/PG.
6. Press and hold the Push-SW of the intelligent tap for 1 second or longer. The setting of F3SG-SR/PG are backed up in the intelligent tap.

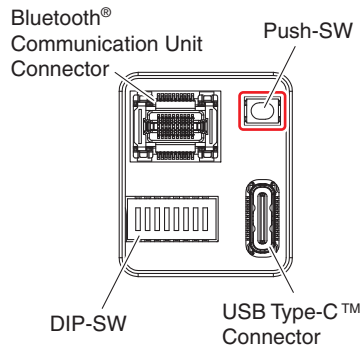

7. Check the indicators if backup is complete.

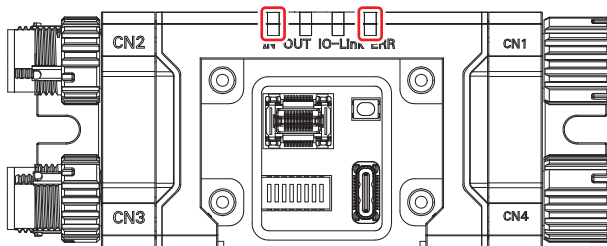

<Status of indicators at normal end>
 OUT :Flashing yellow at 0.5 second cycle (quick flashing)
 ERR :Not lit

If the indicators are different from the above, turn off power of the intelligent tap and F3SG-SR/PG, make sure that the wiring is proper, and go back to step 2. to perform the steps again.

8. Turn off power of F3SG-SR/PG.
9. Set the DIP-SW channel 1 ON.

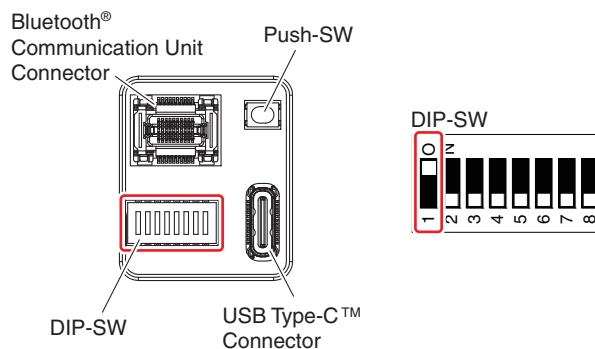

10. Turn on power of the intelligent tap and F3SG-SR/PG.
11. Check that F3SG-SR/PG runs as intended. If it does not, turn off power of the intelligent tap and F3SG-SR/PG, make sure that the wiring is proper, and go back to step 2. to perform the steps again.
12. Turn off power of the intelligent tap and F3SG-SR/PG.

- To finish the maintenance task and start normal operation of the facility, perform the followings.

1. To finish the maintenance task and start normal operation of the facility, perform the followings. (Recommended tightening torque: 0.35N•m)

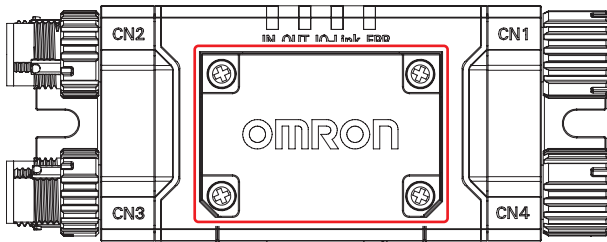

2. If a cable is not attached to CN3, use the torque wrench XY2F-0004 to attach the accessory waterproof cover (for plug). (Recommended tightening torque for waterproof cover (for plug): 0.39 to 0.49N•m)

3. If a cable is not attached to CN4, attach the accessory waterproof cover (for socket).

3-10-3. Applying Setting Saved in Intelligent Tap to Sensor Using Restoration

Before performing this step, use the setup information stored in the intelligent tap using the backup function and SD Manager 3 to change the F3SG-SR/PG settings. For how to save the setup information using the backup function, refer to 3-10-2. *Saving Sensor Setting to Intelligent Tap Using Backup Function*. For how to save the settings to the intelligent tap using SD Manager 3, refer to 3-8. (1) *To edit backup/restoration data in the Intelligent Tap* and 4-3. *Changing Settings with SD Manager 3*.

■ Work steps

1. If power of the intelligent tap or F3SG-SR/PG is ON, turn it OFF.
2. Use a Phillips screwdriver to remove the cover of the intelligent tap.

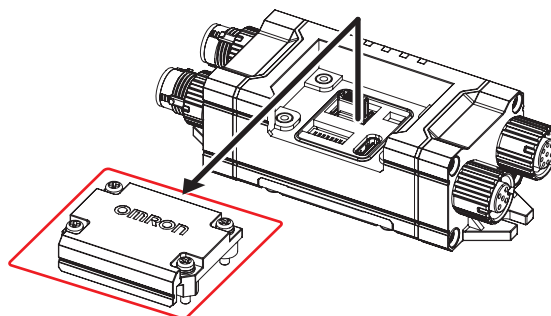

- Set the DIP-SW channel 1 ON and channel 2 OFF.

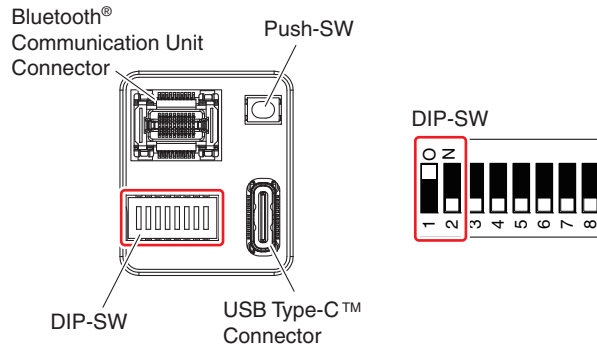

- Set the DIP-SW channels 3 to 8 OFF.

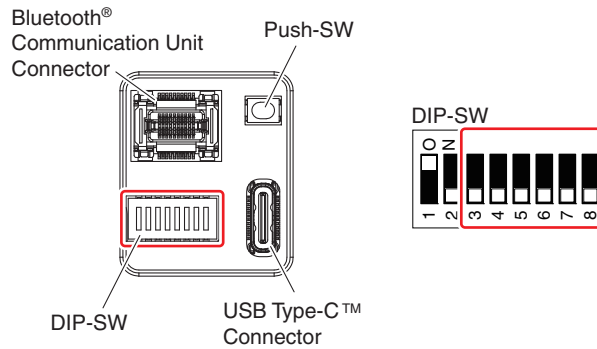

- If the intelligent tap is not connected yet, connect it to F3SG-SR/PG. Refer to the chart in 3-10-1. *Setting F3SG-SR/PG with DIP Switch*, ■Step 5. to make sure that the system has the configuration with intelligent tap.
- Turn on power of the intelligent tap and F3SG-SR/PG.
- Check the indicators on the intelligent tap if restoration is complete.

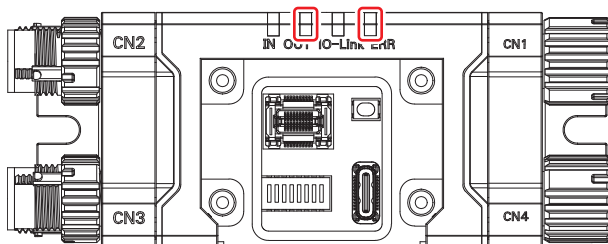

<Status of indicators at normal end>
 OUT :Flashing green at 0.5 second cycle
 (quick flashing)
 ERR :Not lit

If restoration is not complete, the indicators are as shown below.

■ If intelligent tap's ERR indicator is red ON

The sensor model and/or configuration settings stored in the intelligent tap differ from those that are actually connected. Use SD Manager 3 to modify the settings stored in the intelligent tap so that they should correspond with the actual sensor configuration, and go back to step 3. to perform the steps again.

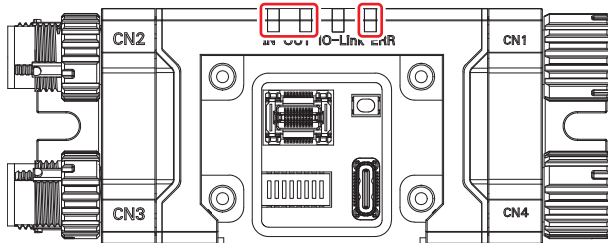

<Status of indicators at abnormal number of beams/configuration error>
 IN :Flashing yellow at 0.5 second cycle (quick flashing)
 OUT :Flashing green at 0.5 second cycle (quick flashing)
 ERR :Red ON

■ If the OUT indicator of the intelligent tap flashes green in 2.0 second cycle

The restoration is not performed.

The number of beams of the sensor stored in the intelligent tap differs from that of the sensor actually connected.

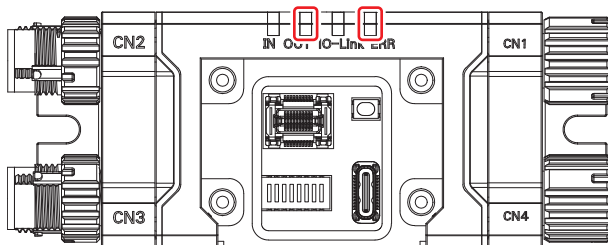

<Status of indicators at abnormal number of beams>
 OUT :Flashing green at 2.0 second cycle (slow flashing)
 ERR :Not lit

If a function related to the number beams is used, such as blanking, use SD Manager 3 to modify the settings stored in the intelligent tap so that they should correspond with the actual sensor configuration, and go back to step 3. to perform the steps again.

If no function is used that is related to the number of beams, press and hold the Push switch of the intelligent tap for 1 second or longer. Restoration starts.

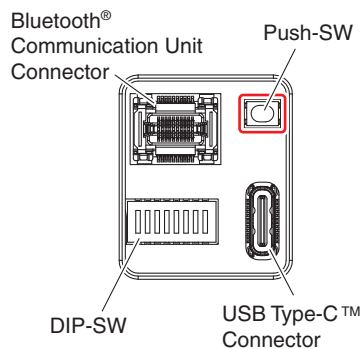

8. Turn off power of the intelligent tap and F3SG-SR/PG, then turn on power of them.



CHECK!

The settings are not enabled unless the intelligent tap and F3SG-SR/PG are restarted.

9. Check that F3SG-SR/PG runs as intended.

If it does not, use SD Manager 3 to check the settings, and go back to step 3. to perform the steps again.

10. Turn off power of the intelligent tap and F3SG-SR/PG.

- To finish the maintenance task and start normal operation of the facility, perform the followings.

1. Use a Phillips screwdriver to attach the cover of the intelligent tap.
(Recommended tightening torque: 0.35•Nm)

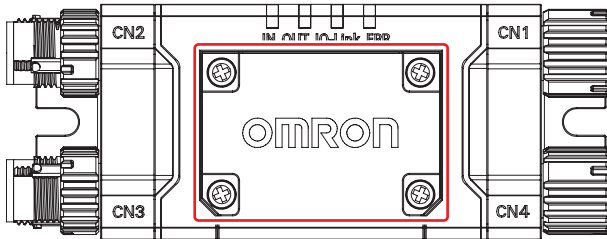

2. If a cable is not attached to CN3, use the torque wrench XY2F-0004 to attach the accessory waterproof cover (for plug).
(Recommended tightening torque for waterproof cover (for plug): 0.39 to 0.49N•m)
3. If a cable is not attached to CN4, attach the accessory waterproof cover (for socket).

3-10-4. Replacing Intelligent Tap

Replace the existing intelligent tap with a new one.

3-10-4-1. Setting with DIP-SW

This applies to a case that F3SG-SR/PG settings were changed by DIP-SW.

■ Work steps

1. If power of the intelligent tap or F3SG-SR/PG is ON, turn it OFF.
2. Remove the existing intelligent tap from the facility.
3. Remove the cover of the new intelligent tap to attach.

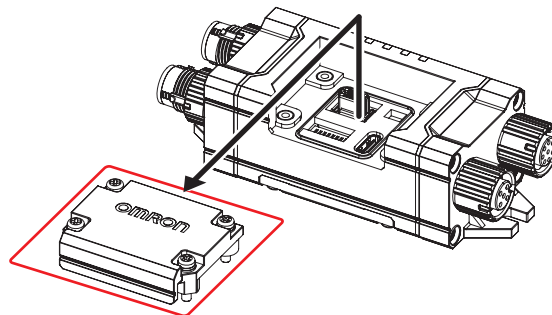

- Set the DIP-SW channels 1 and 2 ON of the new intelligent tap to attach.

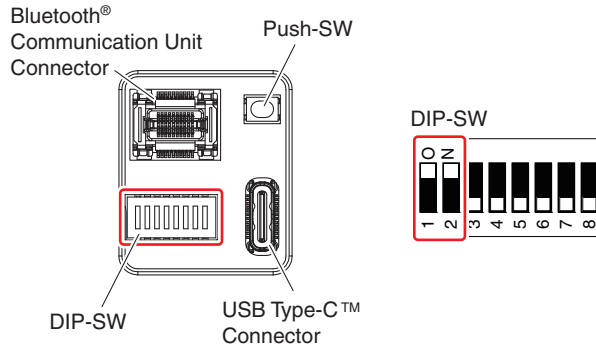

- Set the new intelligent tap's DIP-SW channels 3 to 8 as those of the existing one.

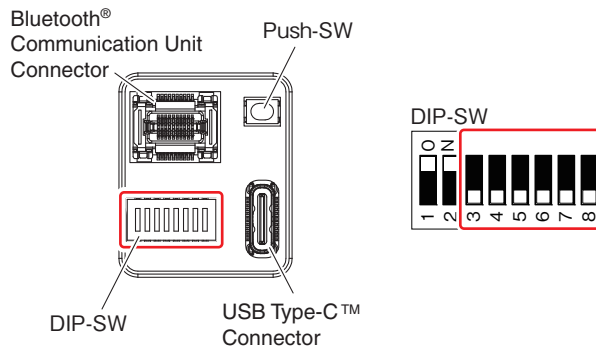

For details of the channels, refer to 3-5. *DIP Switch on Intelligent Tap.*

- Refer to the chart in 3-10-1. *Setting F3SG-SR/PG with DIP Switch*, ■ Step 5. to connect the new intelligent tap to F3SG-SR/PG.
- Turn on power of the new intelligent tap and F3SG-SR/PG. Restoration is automatically performed.
- Check the indicators on the intelligent tap if restoration is complete.

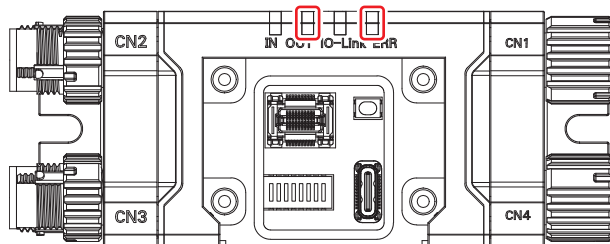

<Status of indicators at normal end>
 OUT :Flashing green at 0.5 second cycle (quick flashing)
 ERR :Not lit

If the indicators are different from the above, turn off power of the intelligent tap and F3SG-SR/PG, make sure that the wiring is proper, and go back to step 4. to perform the steps again.

When power of the newly purchased intelligent tap is turned ON for the first time, backup is automatically performed once and IN indicator turns ON in yellow for a while. After then, if the indicators are under the statuses above, the restoration has been normally completed.
 CHECK!

- Turn off power of the intelligent tap and F3SG-SR/PG, then turn on power of them.

The settings are not enabled unless the intelligent tap and F3SG-SR/PG are restarted.
 CHECK!

- 10.** Check that F3SG-SR/PG runs as intended.
If it does not, turn off power of the intelligent tap and F3SG-SR/PG, make sure that the wiring is proper, and go back to step 4. to perform the steps again.

- 11.** Turn off power of the intelligent tap and F3SG-SR/PG.

- To finish the maintenance task and start normal operation of the facility, perform the followings.

- 1.** Use a Phillips screwdriver to attach the cover of the intelligent tap.
(Recommended tightening torque: 0.35N•m)

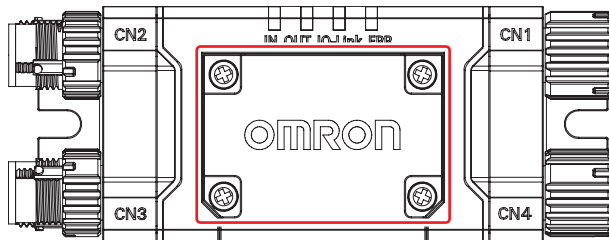

- 2.** If a cable is not attached to CN3, use the torque wrench XY2F-0004 to attach the accessory waterproof cover (for plug).
(Recommended tightening torque for waterproof cover (for plug): 0.39 to 0.49N•m)

- 3.** If a cable is not attached to CN4, attach the accessory waterproof cover (for socket).

3-10-4-2. Settings Configured by Setup Information Stored in Intelligent Tap

This applies to a case that F3SG-SR/PG settings were changed by backup data or SD Manager 3.

- Work steps

- 1.** If power of the intelligent tap or F3SG-SR/PG is ON, turn it OFF.
- 2.** Remove the existing intelligent tap from the facility.
- 3.** Use a Phillips screwdriver to remove the cover of the new intelligent tap to attach.

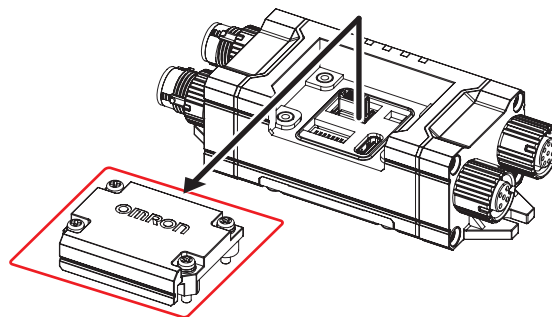

- Set the DIP-SW channels 1 to 8 OFF of the new intelligent tap to attach.

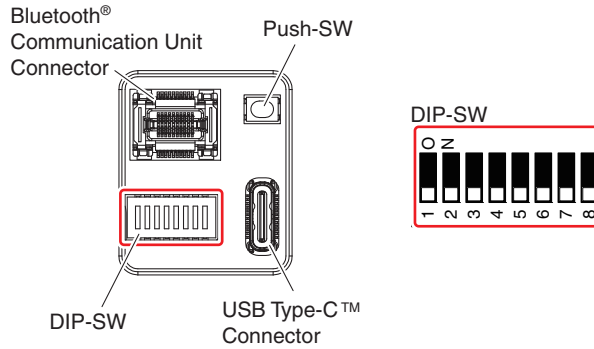

- Refer to the chart in 3-10-1. *Setting F3SG-SR/PG with DIP Switch*, ■Step 5. to connect the new intelligent tap to F3SG-SR/PG (configuration shown below).
- Press and hold the Push-SW of the attached intelligent tap for 1 second or longer. The setting of F3SG-SR/PG are backed up in the intelligent tap.

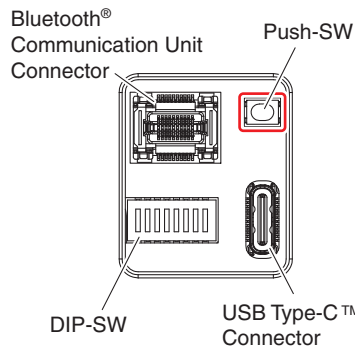

- Check the indicators if backup is complete.

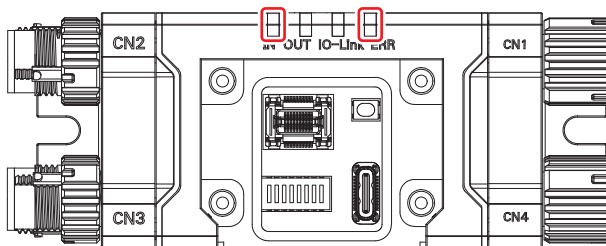

<Status of indicators at normal end>
 IN :Flashing yellow at 0.5 second cycle (quick flashing)
 ERR :Not lit

If the indicators are different from the above, turn off power of the intelligent tap and F3SG-SR/PG, make sure that the wiring is proper, and go back to step 4. to perform the steps again.

- Turn off power of F3SG-SR/PG.
- Set the DIP-SW channel 1 ON.

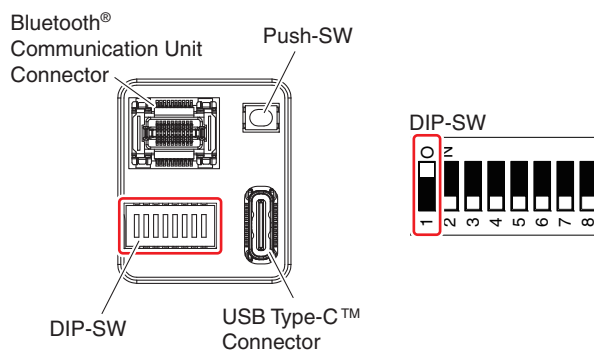

10. Turn on power of the intelligent tap and F3SG-SR/PG.
11. Check that F3SG-SR/PG runs as intended.
If it does not, turn off power of the intelligent tap and F3SG-SR/PG, make sure that the wiring is proper, and go back to step 4. to perform the steps again.
12. Turn off power of the intelligent tap and F3SG-SR/PG.
 - To finish the maintenance task and start normal operation of the facility, perform the followings.

1. Use a Phillips screwdriver to attach the cover of the intelligent tap.
(Recommended tightening torque: 0.35N•m)

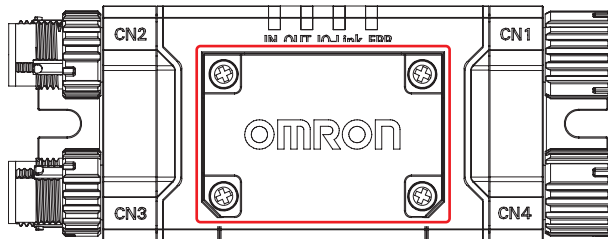

2. If a cable is not attached to CN3, use the torque wrench XY2F-0004 to attach the accessory waterproof cover (for plug).
(Recommended tightening torque for waterproof cover (for plug): 0.39 to 0.49N•m)
3. If a cable is not attached to CN4, attach the accessory waterproof cover (for socket).

Chapter 4 Setting with SD Manager 3

4-1. Overview and Specifications	202
4-1-1. Overview of Configuration Tool	202
4-1-2. System Environment	203
4-1-2-1. PC Environment	203
4-1-2-2. Smartphone Environment	203
4-1-3. Connection Method to Use Configuration Tools	204
4-1-3-1. Connection Patterns of F3SG-SR/PG, Intelligent Tap, and Each Device	204
4-1-3-2. Connection Procedure When Using USB Connector	207
4-1-3-3. Connection Procedure When Using Bluetooth® Communication Unit (F39-SGBT)	208
4-1-4. SETTING State of F3SG-SR/PG with SD Manager 3 Connected	212
4-2. Basic Operation of SD Manager 3	214
4-2-1. How to Install/Uninstall SD Manager 3	214
4-2-1-1. Downloading SD Manager 3	214
4-2-1-2. Installing SD Manager 3	214
4-2-1-3. How to Uninstall SD Manager 3	216
4-2-1-4. Installing Driver of Intelligent Tap	217
4-2-2. How to Update SD Manager 3	217
4-2-3. Getting Started, Description on Top Page and Each Button, and Shutting Down	217
4-2-3-1. Getting Started	217
4-2-3-2. Description on Top Page and Each Button	218
4-2-3-3. Displaying/Hiding Docked Windows	220
4-2-3-4. Shutting Down	220
4-2-4. Starting SD Manager 3 Offline	221
4-2-4-1. Creating New Configuration File	221
4-2-4-2. Reading Configuration from PC	222
4-2-4-3. Saving New Configuration File to PC	222
4-2-4-4. Switching Offline to Online	222
4-2-5. Logging In/Logging Out	223
4-2-5-1. Logging In	223

4-2-5-2. Logging Out	225
4-2-6. Password Protection	226
4-2-6-1. Access Restriction	226
4-2-6-2. Changing Password	226
4-2-6-3. Forgot the Password?	226
4-2-6-4. Confirming Lot No. of Intelligent Tap	226
4-2-6-5. Resetting the Initial Password to "0000"	227
4-2-7. Reading/Saving/Writing Configuration of Intelligent Tap	228
4-2-7-1. Reading Configuration from Intelligent Tap	228
4-2-7-2. Saving Configuration of Intelligent Tap in PC	228
4-2-7-3. Writing Configuration into Intelligent Tap	229
4-2-8. Viewing Current Configuration	231
4-2-9. Safety Distance Calculation	232
4-3. Changing Settings with SD Manager 3	233
4-3-1. Preparing to Change Settings	233
4-3-2. I/O Settings	234
4-3-2-1. Interlock/External Device Monitoring (EDM)/PSDI	234
4-3-2-2. Reset Input Time	235
4-3-2-3. Teach-in Input	236
4-3-2-4. External Test Input	237
4-3-3. Auxiliary Output/Lamp Setting	238
4-3-3-1. Auxiliary Output/Lamp	238
4-3-3-2. Designated Beam Output	240
4-3-3-3. Area Beam Indicator (ABI)	243
4-3-4. Safety Function Setting	245
4-3-4-1. Fixed Blanking	245
4-3-4-2. Floating Blanking	248
4-3-4-3. Muting/Override	250
4-3-4-4. Pre-Reset	255
4-3-4-5. Reduced Resolution	256
4-3-4-6. Warning Zone	257
4-3-4-7. PSDI	259
4-3-5. Operating State Setting	260
4-3-5-1. Response Time Change	260
4-3-5-2. Stable Light Threshold Adjustment	261
4-3-5-3. Operating Range Selection	262
4-3-6. Setting Initialization	263
4-3-7. Backup/Restoration	265
4-4. Monitoring with SD Manager 3	266
4-4-1. Monitoring	266
4-4-1-1. Incident Light/Ambient Light	266
4-4-1-2. Operating Status Monitoring	268
4-4-2. Muting Statistics Information	270

4-4-3. Maintenance Information	274
4-4-3-1. Error Log Information	274
4-4-3-2. Warning Log	276
4-4-3-3. Intelligent Tap Log	277
4-4-3-4. Power-On Time/Load Switching Frequency	278
4-4-3-5. Instantaneous Block Detection Information	280
4-5. Basic Operation of SD Manager 3 Mobile APP	281
4-5-1. How to Install/Uninstall SD Manager 3 Mobile APP	281
4-5-1-1. Installing SD Manager 3 Mobile APP	281
4-5-1-2. Uninstalling SD Manager 3 Mobile APP	281
4-5-2. How to Update SD Manager 3 Mobile APP	281
4-5-3. Pairing (Connection Verification)	281
4-5-4. Getting Started, Main Screen, Version Confirmation, and Shutting Down	282
4-5-4-1. Getting Started	282
4-5-4-2. Main Screen	284
4-5-4-3. Version Information	285
4-5-4-4. Shutting Down	286
4-5-5. Monitoring with SD Manager 3	287
4-5-5-1. Incident/Ambient Light Level Monitoring	287
4-5-5-2. Status Monitoring Information	288
4-5-5-3. Maintenance Information	290
4-6. SD Manager 3 Application Example	292
4-6-1. Changing F3SG-SR/PG settings using SD Manager 3	292
4-6-2. Reading out F3SG-SR/PG settings using SD Manager 3	295
4-6-3. Monitoring F3SG-SR/PG status using SD Manager 3	298
4-6-4. Changing settings and/or monitoring status of multiple F3SG-SR/PG setting/status using one Intelligent Tap and SD Manager 3	300

WARNING

Make sure the Responsible Person test the operation of the F3SG-SR/PG after setting with the SD Manager 3 to verify that the F3SG-SR/PG operates as intended. Make sure to stop the machine until the test is complete. Unintended settings may cause a person to go undetected, resulting in serious injury.



4-1. Overview and Specifications

4-1-1. Overview of Configuration Tool

The user can configure various functions and view operating states of the F3SG-SR/PG Safety Light Curtain, using the following accessories and tools.

- Intelligent Tap (F39-SGIT-IL3)
- Bluetooth® Communication Unit (F39-SGBT)
- Configuration Tools (SD Manager 3 *1/ SD Manager 3 Mobile APP)

*1. By installing SD Manager 3, SD Manager 2 is installed simultaneously by the installer. Before executing SD Manager, confirm the model of the light curtain product used. The model of the light curtain product compatible with each version of SD Manager is as follows:

- SD Manager 3 is usable only for the models of F3SG-SR/PG Series.
- SD Manager 2 is usable only for the models of F3SG-RA Series.

4-1-2. System Environment

4-1-2-1. PC Environment

To use SD Manager 3, the following PC environment is necessary.

Operating system (OS)	Windows 10 32-bit or 64-bit edition, Windows 11 Language: Japanese, English
CPU	1 GHz or higher
Memory capacity	1 GB or higher for 32-bit edition of Windows 10 2 GB or higher for 64-bit edition of Windows 10 4 GB or higher for 64-bit edition of Windows 11
Operating condition	.NET Framework 3.5 must be installed and activated (requires an activation process.) .NET Framework 4.5.2 or higher is installed Bluetooth® wireless technology is incorporated (to use Bluetooth® Communication Unit).

4-1-2-2. Smartphone Environment

To use SD Manager 3 Mobile APP, the following smartphone environment is necessary.

Operating system (OS)	Android 7.x (Nougat) Android 8.x (Oreo) Android 9.x (Pie) Android 10.x
Operating condition	The computer must be equipped with the Bluetooth® wireless technology.

4-1-3. Connection Method to Use Configuration Tools

The communication tools compatible with Intelligent Tap F39-SGIT-IL3 are different between PC and smartphone.

For the respective compatible communication tools, refer to the table below.

The Bluetooth® communication unit (F39-SGBT) is usable for all devices of PC and smartphone.

Compatible communication tools for PC and smartphone

Communication tool	Windows PC	Android smartphone
USB cable	Yes	No
Bluetooth® communication unit	Yes	

Yes: Communication is usable

No: Communication is not usable



When connecting with the configuration tools, do not execute connection using the USB connector and connection by the Bluetooth® communication unit simultaneously. Otherwise, the system might not operate correctly.

4-1-3-1. Connection Patterns of F3SG-SR/PG, Intelligent Tap, and Each Device

The connection patterns of F3SG-SR/PG, Intelligent Tap, and each device are as follows.

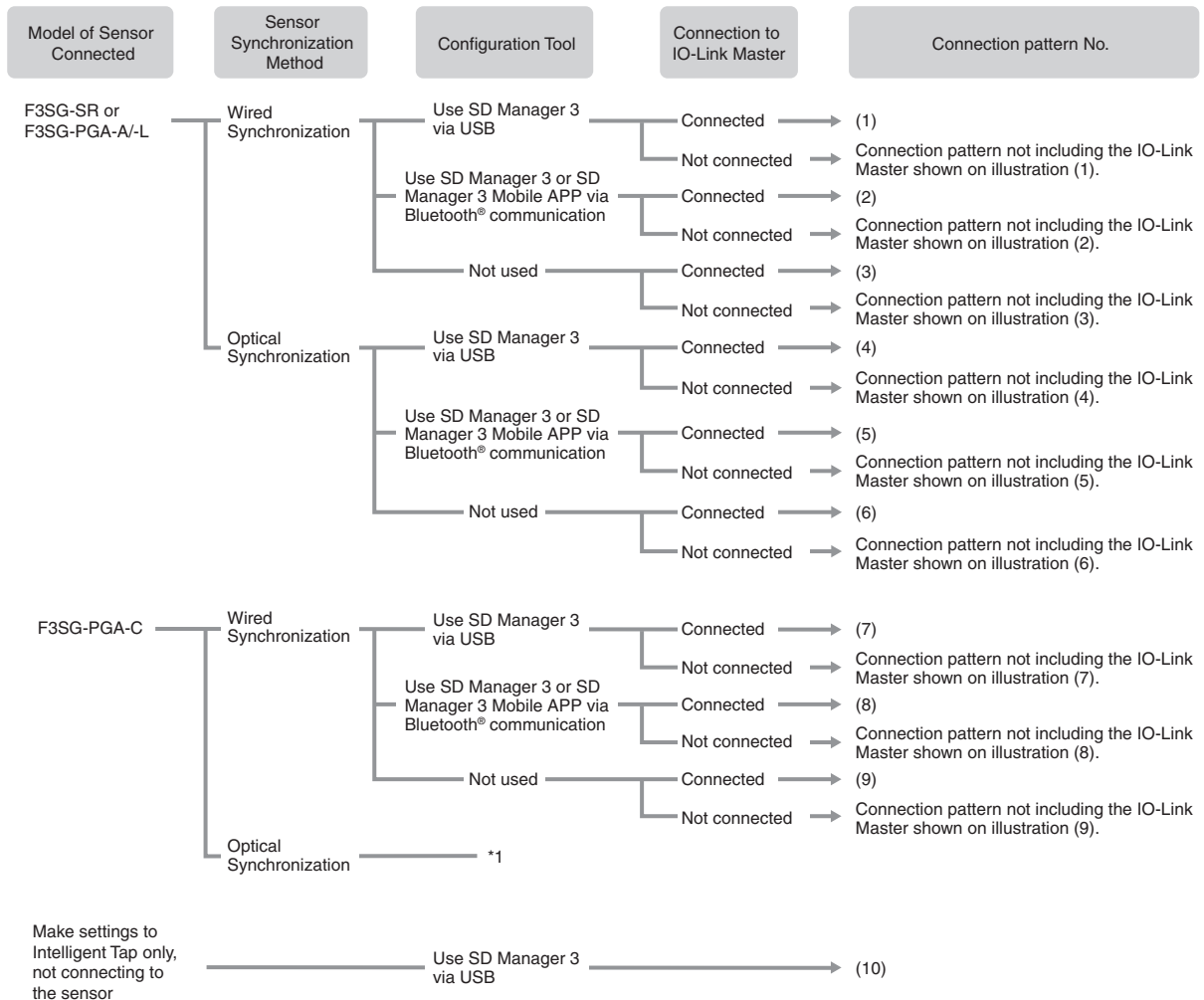

*1 By connecting the emitter/receiver of F3SG-PGA-C with the Intelligent Tap, the product operates in the Wiring Synchronization. To connect a F3SG-PGA-C product operating in the Optical Synchronization with SD Manager 3, connect the Intelligent Tap temporarily, and remove it after settings are made. For further information on the operation in the Wiring Synchronization and Optical Synchronization of F3SG-PGA-C, refer to 2-3. *Mutual Interference Prevention*.

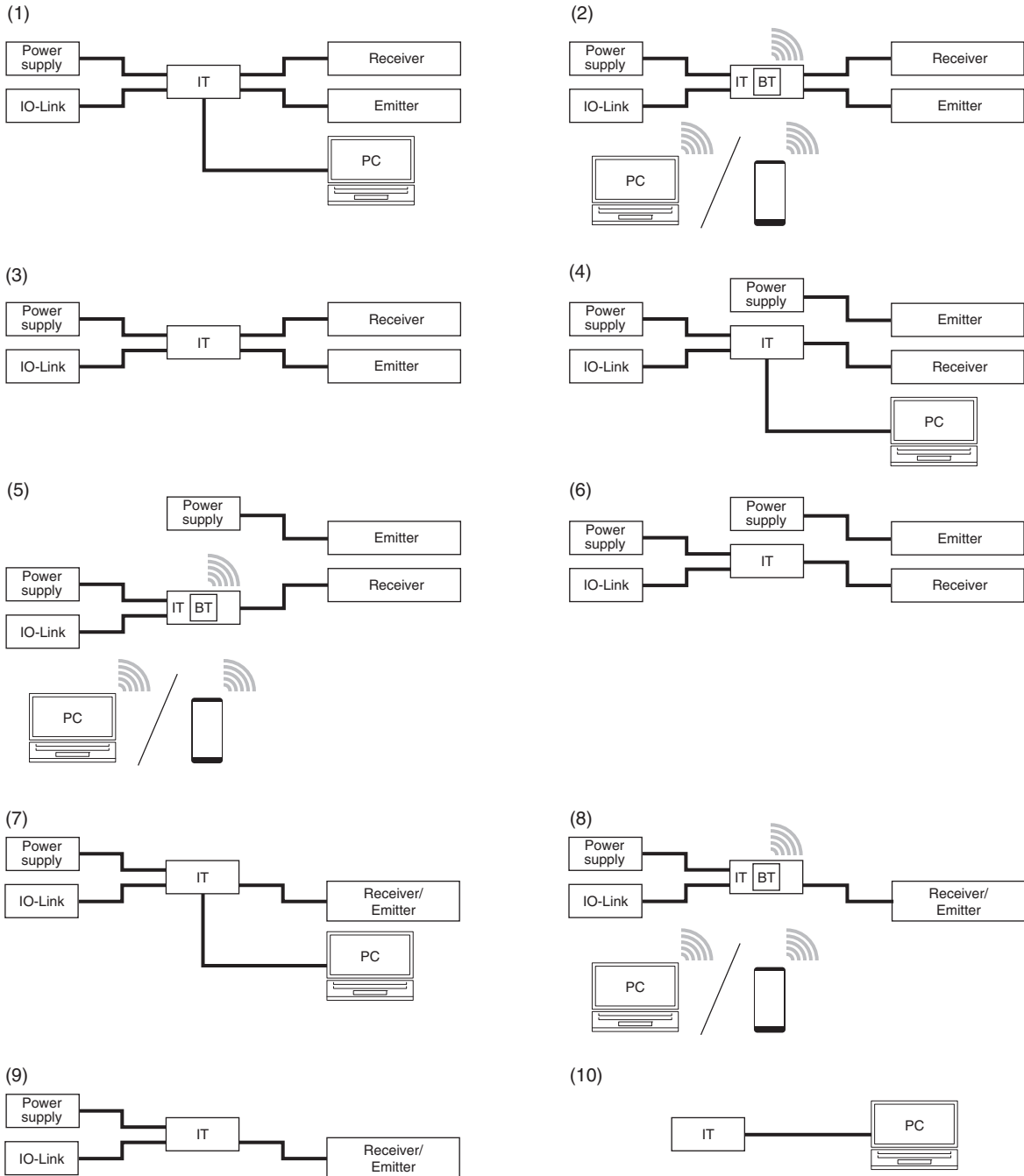

IT: Intelligent Tap
 BT: Bluetooth® communication unit
 IO-Link: IO-Link Master

For the patterns (1), (4) and (7), turn the power on and start the SD Manager 3 on the PC.
 For the pattern (10), the power is supplied from the PC to the Intelligent Tap.

When connecting the emitter and receiver with the Intelligent Tap as shown in the above patterns (2) to (4), it is possible to make settings to the emitter and receiver and perform IO-Link communication, Backup and Restoration.

If the emitter is not connected with the Intelligent Tap like patterns (5), (6) above, there are the following restrictions.

- As synchronization method, only the optical synchronization is usable.
- It is unable to configure the following function using the DIP Switch on the Intelligent Tap.

Operating range selection

- It is unable to configure the following functions using SD Manager 3.
External test, operating range selection, lamp, area beam indicator (ABI), and vibration detection
- It is unable to monitor the emitter using the configuration tools.
- The backup and restoration functions of the emitter are not usable.
- The information of the emitter cannot be obtained via IO-Link.

If connecting the emitter/receiver with the Intelligent Tap as shown by illustration (7) - (9) above, setting change of the emitter/receiver, IO-Link communications, and backup/restoration can be performed. Only the Wiring Synchronization is usable as synchronization method.

Before connecting with each device, confirm that the power of the F3SG-SR/PG and Intelligent Tap is OFF. After connection is completed, turn ON the power and start up the F3SG-SR/PG and Intelligent Tap.

4-1-3-2. Connection Procedure When Using USB Connector

1. Connect the USB connector with the Intelligent Tap as follows.

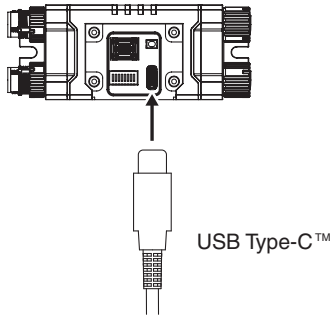

2. When you change the settings by using SD Manager 3, turn Positions 1 and 2 as shown below.

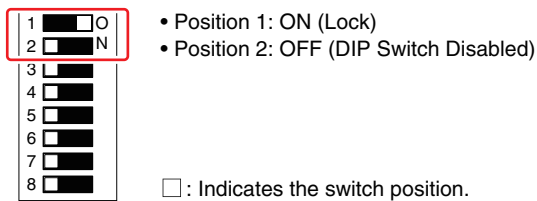

3. Connect the USB connector with the PC's USB terminal.

When the Intelligent Tap is powered up, the OUT indicator of the Intelligent Tap is illuminated in red or green.

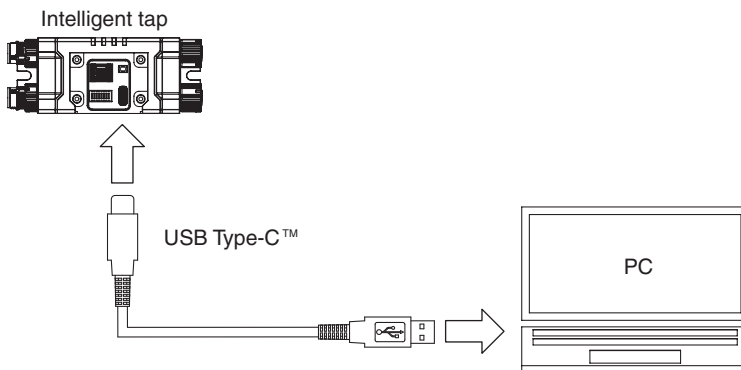

4. To restart the Intelligent Tap, unplug the USB connector from the Intelligent Tap and plug it again.

If the Intelligent Tap is connected with F3SG-SR/PG, turn ON the external power supply connected with the Intelligent Tap again.

After the Intelligent Tap restarts and the power is turned ON, the OUT indicator of the Intelligent Tap is illuminated in red or green.

[Not connecting F3SG-SR/PG]

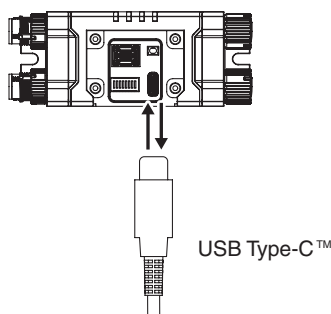

[Connecting F3SG-SR/PG]

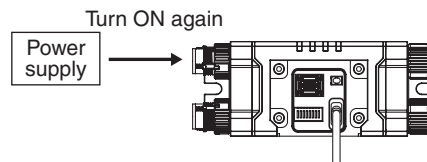

4-1-3-3. Connection Procedure When Using Bluetooth® Communication Unit (F39-SGBT)

⚠ WARNING

When pairing your device with the F39-SGBT Bluetooth® Communication Unit, make sure that the model name and serial number of the sensor to be configured match the information on your device.



Do not use the F39-SGBT Bluetooth® Communication Unit in close proximity to medical equipment such as a pacemaker. Radio wave may affect the operation of such equipment.



1. When you change the settings by using SD Manager 3, turn Positions 1 and 2 as shown below.

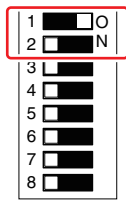

- Position 1: ON (Lock)
- Position 2: OFF (DIP Switch Disabled)

: Indicates the switch position.

2. Connect the Bluetooth® communication unit with the Intelligent Tap as follows.

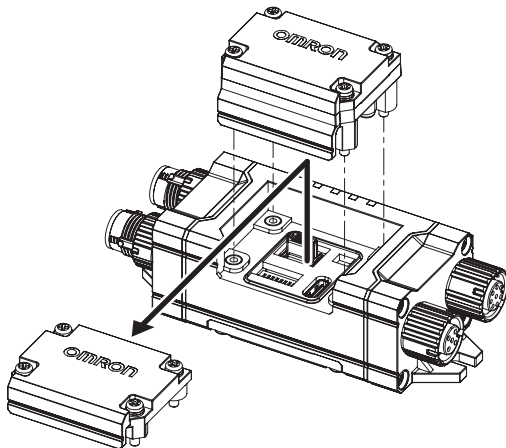

For the details of the Bluetooth® communication unit, refer to “F3SG-SR/PG Series Supported Bluetooth® Communication Unit F39-SGBT Manual.”

The configuration changed by SD Manager 3 is saved in the internal memories of the Intelligent Tap and F3SG-SR/PG.

CHECK!

If the Position 2 of the DIP Switch on the Intelligent Tap is turned ON (DIP Switch Enabled) after configuration is changed, the tap operates based on the setting of the DIP Switch. If the Position 2 of the DIP Switch is turned OFF (DIP Switch Disabled) again, the tap operates based on the configuration memorized in its internal memory.

CHECK!

The configuration data of the Intelligent Tap can be read out even if Position 2 of the DIP Switch is ON (DIP Switch Enabled).

CHECK!

■ Pairing (Connection Verification)

Pairing is the process required for the Bluetooth® Communication Unit and a device with Bluetooth® wiring technology to recognize and connect with each other.

Indications and operations of the pairing process are different depending on a Bluetooth® device used. Always refer to instruction manuals of such a device when pairing the devices.



CHECK!

When the Bluetooth® Communication Unit and a Bluetooth® device are not paired, it is not possible to connect to the Bluetooth® Communication Unit. These must be paired in advance.



CHECK!

Once the Bluetooth® Communication Unit and a Bluetooth® device are paired, it is not necessary to pair them again.

The following is an example of the pairing process using a Windows-10-based PC.

This example assumes that a Bluetooth® adapter is incorporated or installed in the PC.

[Example]

1. Confirm that the Bluetooth® communication unit is connected with the Intelligent Tap correctly, and turn ON the power to start up the F3SG-SR/PG and Intelligent Tap.
2. Right-click the [Start] button of Windows, and click [Devices] on the [Settings] menu.

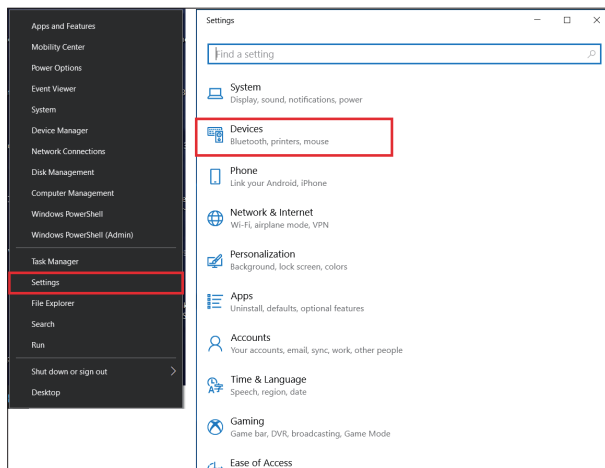

3. Click [Bluetooth & other devices] and click [Add Bluetooth or other device].

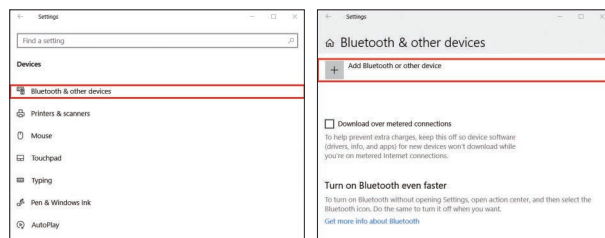

4. On the screen to select the type of the device added, click [Bluetooth].

- The searched devices are displayed like the screen below, so click the device connected. For the device names of the Intelligent Tap connected with the Bluetooth® communication unit and F3SG-SR/PG, the serial number and model name of the F3SG-SR/PG are displayed. For the F3SG-SR/PG in cascade connection, the serial number and model name of the primary sensor are displayed.



When pairing with more than one device, adding a device must be carried out one by one.

CHECK!

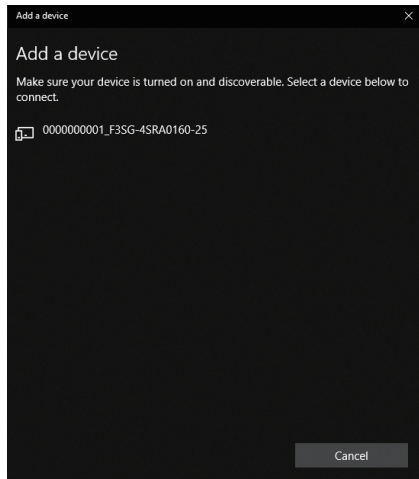

- The screen below is displayed and a necessary device driver is installed.

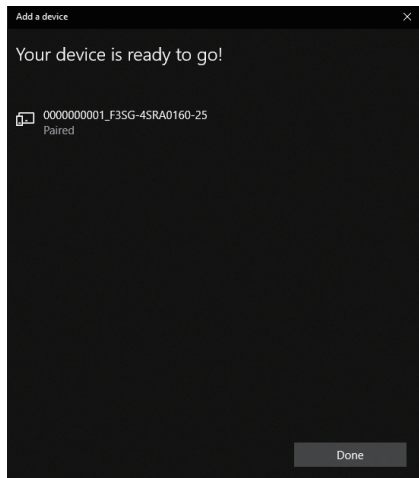

- Confirm that the installation of the device driver is fully completed. When the installation is complete, the message shown below is displayed.

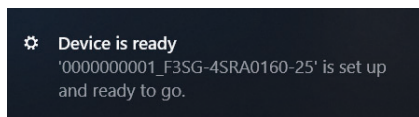

Now the pairing is complete.

■ How to check a COM port when connected to a Bluetooth® Communication Unit

1. Right-click the Windows [Start] button and click [Devices] on the [Settings] menu.
2. Click [Bluetooth and other devices] and click [Devices and Printers] below [Related Settings].

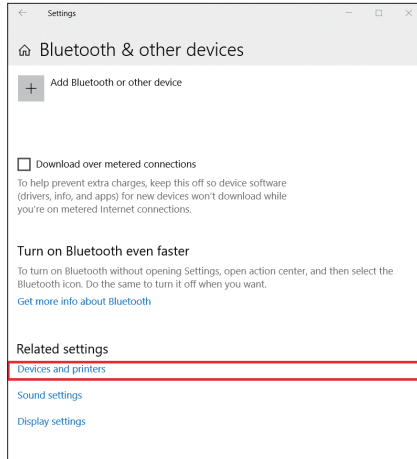

3. When the screen below is displayed, right click the icon of a target device to check a COM port number, and then click [Properties]. If there are more than one connectable Bluetooth® Communication Unit, select a serial number and model name of a target device.

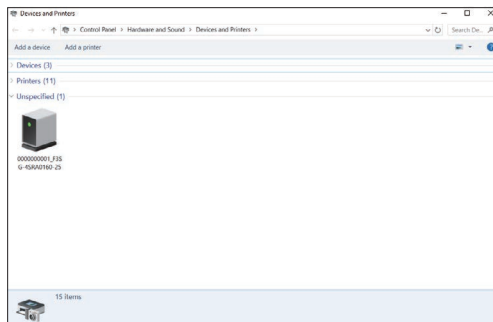

4. When selecting the [Hardware] tab, the screen below is displayed that indicates a COM port. In this example, the device “000000001_F3SG-4SRA0160-25” is set to COM7.

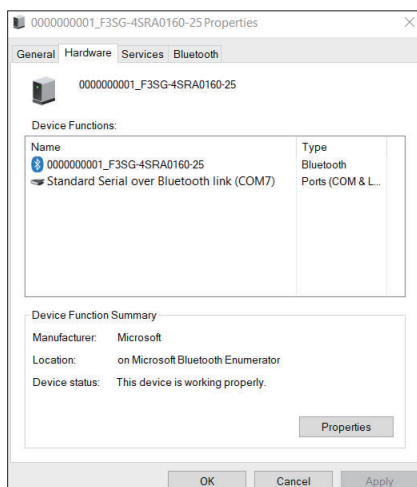

4-1-4. SETTING State of F3SG-SR/PG with SD Manager 3 Connected

The F3SG-SR/PG connected with the Intelligent Tap can be transitioned to the SETTING state by the SD Manager 3.

In the SETTING state, two types of access levels called operator level and administrator level can be selected.

 For operator and administrator levels, refer to 4-2-5-1. *Logging In*

In the SETTING state, the F3SG-SR/PG operates as follows.

- The safety outputs are in the OFF state.
- The LED indicator blinks in a cycle corresponding to the access level.

[Operation of LED indicator]

Sensor	Indicator		Access Level	
			Operator Level	Administrator Level
Emitters of F3SG-SR and F3SG-PGA-A/L	C or CODE	Code A	Blinking once *	Blinking twice *
		Code B	Off	Off
	E or ERR		Off	Off
	L or LONG		Blinking once	Blinking twice
	T or TEST		Blinking once	Blinking twice
	TOP		Off	Off
	BTM		Off	Off
Receivers of F3SG-SR and F3SG-PGA-A/L or Emitter/ Receiver of F3SG-PGA-C	C or CODE	Code A	Blinking once *	Blinking twice *
		Code B	Off	Off
	E or ERR		Off	Off
	O or OSSD		Off	Off
	M or MAINT		Off	Off
	P or PNP		Blinking once *	Blinking twice *
	F or CFG		Blinking once *	Blinking twice *
	S or SEQ		Off	Off
TOP		Off	Off	
BTM		Off	Off	

* Refer to [LED indicator blinking patterns] below for more information on the blinking patterns.

 The LED indicator of the emitter does not operate in the case the Optical Synchronization is enabled as the emitter is not connected to the Intelligent Tap.

CHECK!

[LED indicator blinking patterns]

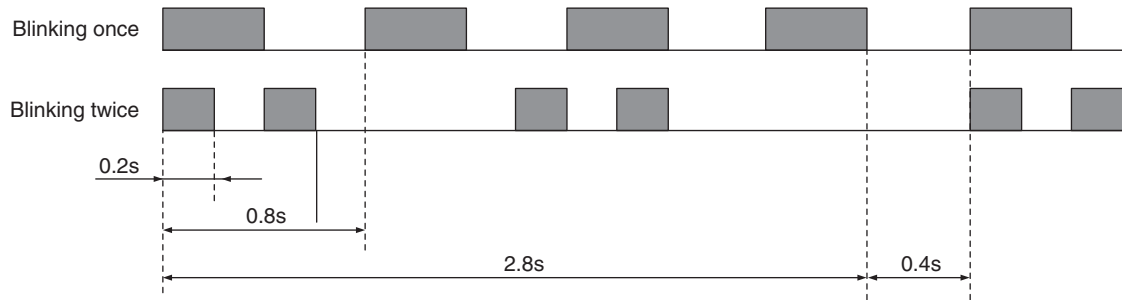

For the access levels, refer to 4-2-5-1. *Logging In.*



CHECK!

When connecting the Intelligent Tap to a F3SG-SR/PG and trying to return the F3SG-SR/PG to [Detecting], follow step 4 of 4-1-3-2. *Connection Procedure When Using USB Connector* to restart the F3SG-SR/PG and Intelligent Tap, or click the [Monitor]  button.

4-2. Basic Operation of SD Manager 3

4-2-1. How to Install/Uninstall SD Manager 3

The following is an example when using a PC that runs on Windows 10.

4-2-1-1. Downloading SD Manager 3

Download SDManager3_Setup.exe from the website and save it to a desired location on a PC.



For detail, refer to your local Omron website.

CHECK!

4-2-1-2. Installing SD Manager 3

1. Confirm that the PC is not connected with the Intelligent Tap using the USB connector or the Bluetooth® communication unit.
2. Double-click on SDManager3_Setup.exe.
3. Select a desired language and click [Next].

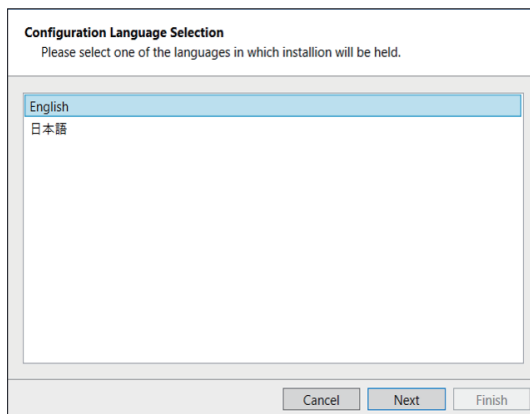

4. The Installation wizard is displayed. Click [Next].

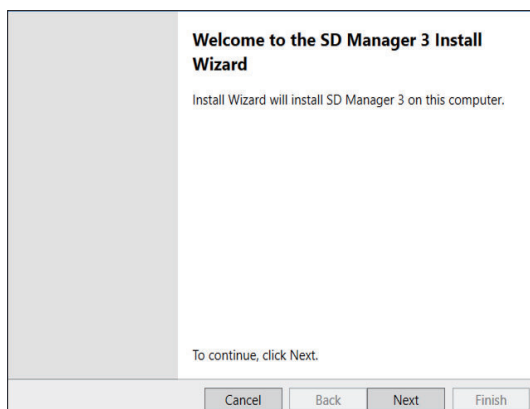

5. Read the software license agreement. If accepting, select [I accept the terms of the license agreement] and click [Next].

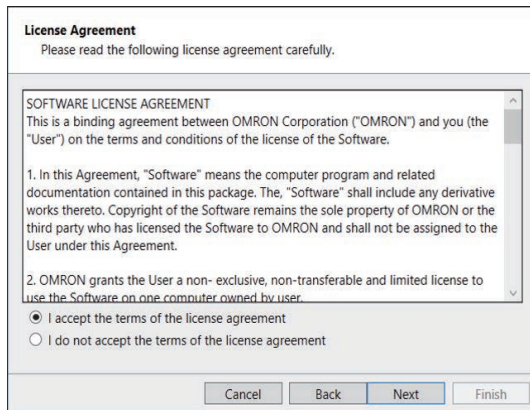

6. Click [Next].
When changing the location to install, click [Change] and select a desired location.

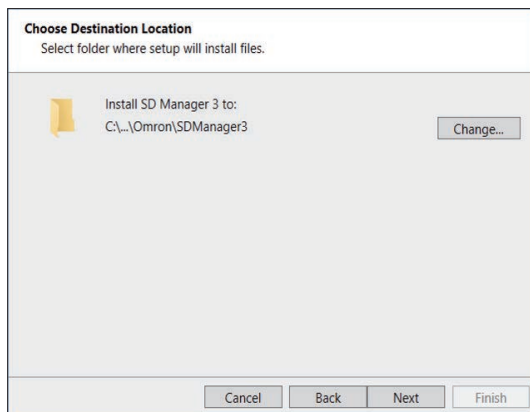

7. The prompt window shown below is displayed. Click [Install] to start the installation.

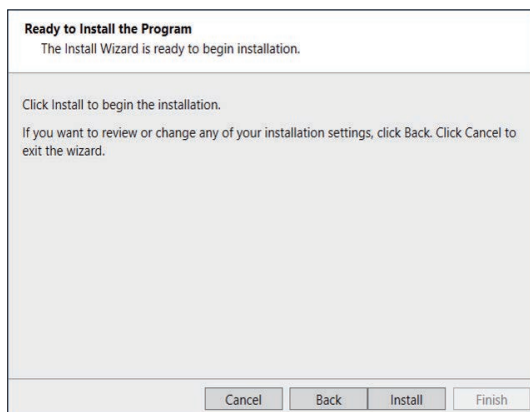

8. Click [Finish]. Now the installation is complete.

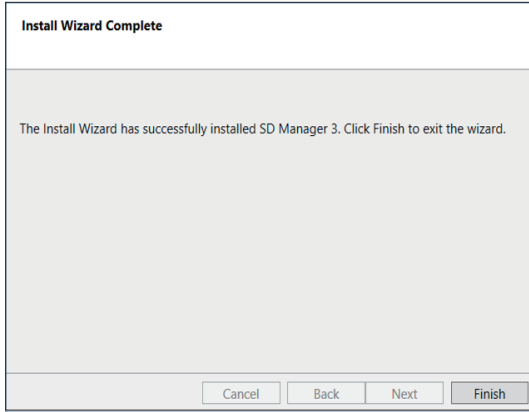

4-2-1-3. How to Uninstall SD Manager 3

You can uninstall SD Manager 3 using the SDManager3_Setup.exe file or Control Panel. The following is an example when using a PC that runs on Windows 10.

1. Double-click on SDManager3_Setup.exe. Confirm [Remove] is selected in the window shown below and click [Next].

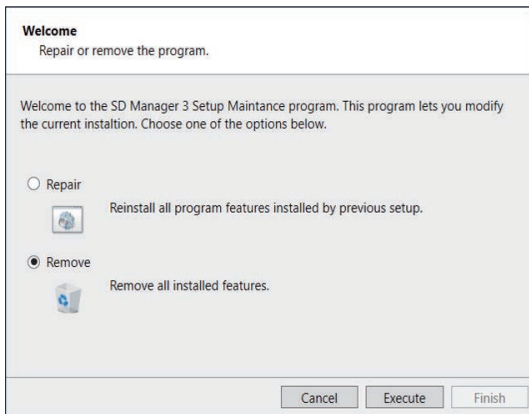

Or from the Start menu, select [Windows System], [Control Panel] and [Uninstall a program]. From the list shown, select [SD Manager 3] and click [Uninstall].

2. The window shown below is displayed when the uninstallation is complete. Click [Finish].

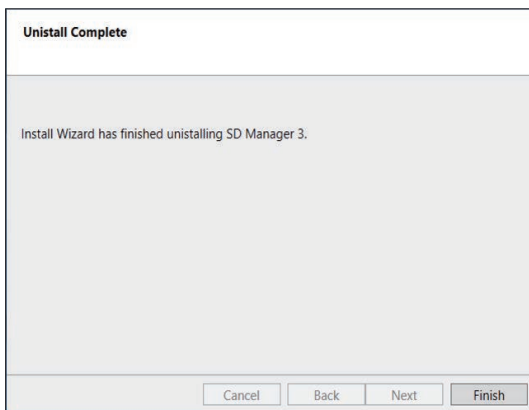

4-2-1-4. Installing Driver of Intelligent Tap

When the installation of SD Manager 3 is complete, the driver of the Intelligent Tap is also completed.

4-2-2. How to Update SD Manager 3

To update an SD Manager 3 installed in a PC to a new version, follow the steps below.

1. Uninstall SD Manager 3 according to the procedure of 4-2-1-3. *How to Uninstall SD Manager 3.*
2. Install a new version of SD Manager 3 according to the procedure of 4-2-1-2. *Installing SD Manager 3.*

4-2-3. Getting Started, Description on Top Page and Each Button, and Shutting Down

4-2-3-1. Getting Started

To get started, select [OMRON] and [SD Manager 3] from the Start menu. SD Manager 3 starts up, and the following dialog is displayed.

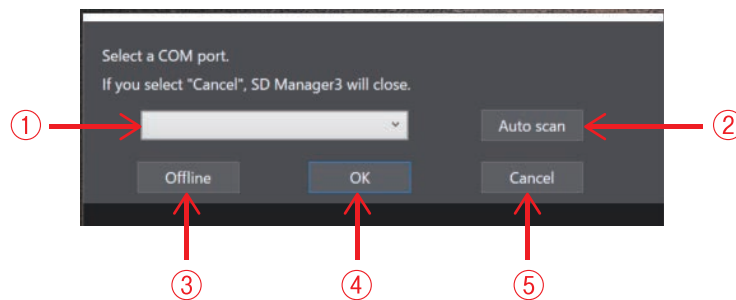

No.	Function	Description
1	Select COM port	Select the COM port with which the USB connector or Bluetooth® Communication Unit is connected.
2	Auto scan	Obtains an available COM port.
3	Offline	Starts the SD Manager 3 in the offline mode.
4	OK	Starts the combination of the SD Manager 3 and Intelligent Tap, or the combination of the SD Manager 3, Intelligent Tap and the F3SG-SR/PG in the online mode.
5	Cancel	Cancels the start of SD Manager 3.

 The COM port with which the Intelligent Tap (F39-SGIT-IL3) is connected can be confirmed by Device Manager. To start Device Manager, right-click the Windows [Start] button and click [Device Manager]. In the [Port (COM & LPT)] category of Device Manager, confirm the COM port assigned to F39-SGIT-IL3.

CHECK! In the example below, it is confirmed that the COM port connected with interface unit F39-SGIT-IL3 is COM7.

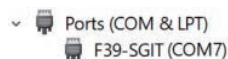

 If there are more than one connectable Bluetooth® Communication Unit, perform the [2: Auto scan] step first, select a COM port of a target device in the [1: Select COM port] step, and then press the [4: OK] button.

CHECK! Refer to ■ *How to check a COM port when connected to a Bluetooth® Communication Unit* under 4-1-3-3. *Connection Procedure When Using Bluetooth® Communication Unit (F39-SGBT)* for more information on how to check the COM port of the F3SG-SR/PG connected.

 In the offline mode, the configuration file can be edited without connecting with the Intelligent Tap.

CHECK!

4-2-3-2. Description on Top Page and Each Button

This section hereafter describes each function taking the top page displayed when F3SG-SR/PG is connected as an example.

Configurable functions are different between F3SG-SR and F3SG-PG.



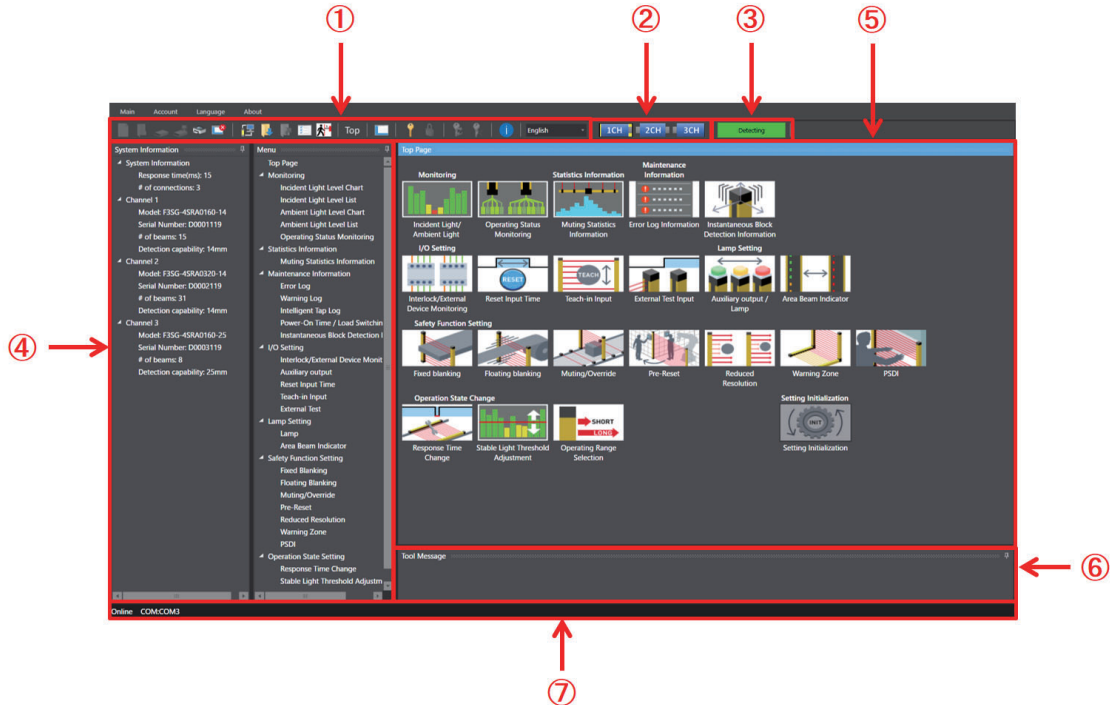

Display of the setting area on the top page is different according to this. For the function list, refer to 1-3-2. List of Key Features.



No.	Function	Description
1	Tool Menu	The menu can be selected using the buttons.
2	Target sensor	Select a target sensor segment to write information to or read information from. The view changes according to actual cascade connection of the F3SG-SR/PG. The example above shows the F3SG-SR system with three sensor segments in cascade connection is connected to the PC.
3	Operating state	Shows the operating state of the F3SG-SR/PG or the connecting state of the Intelligent Tap. <ul style="list-style-type: none"> ■F3SG-SR/PG operating states <ul style="list-style-type: none"> Detecting Operating: The F3SG-SR/PG keeps normal operation. Setting state Setting state: It is possible to read configuration from the F3SG-SR/PG. The safety outputs of the F3SG-SR/PG are in the OFF state. Lockout state Lockout state: The F3SG-SR/PG is in the LOCKOUT State. No connection No connection: The SD Manager 3 is running offline or disconnected from or not properly connected to the F3SG-SR/PG. ■Intelligent Tap connecting state <ul style="list-style-type: none"> Intelligent Tap Only Intelligent Tap connected: Only the Intelligent Tap is connected with SD Manager 3. You can check or change the configuration data in the Intelligent Tap in this state.
4	System Information	Shows information on the F3SG-SR/PG connected. *1
5	Settings	Configurable or other functions are displayed. Unsupported functions are displayed in gray according to the model of the sensor product.
6	View message	Shows messages according to operations and settings of SD Manager 3.
7	Communication setting indicator	The communication setting of the connected F3SG-SR/PG is displayed.

*1. For the sensors with an option number appended to the model number, the option number is not displayed but the standard model number is displayed.

[Descriptions of buttons]

Button	Function	Description
	New	Creates a new configuration file. This is available only when running offline.
	Open	Opens a configuration file.
	Save	Saves or overwrites configuration file.
	Save As	Saves configuration file as another file name.
	Print muting configuration	Prints muting settings.
	Exit	Exits SD Manager 3.
	Monitor	Switches the operating state from [Setting state] to [Operating].
	Read configuration	Reads the configuration data of the Intelligent Tap. Pressing this button switches the safety outputs to the OFF state and the operating state to [Setting state].
	Write configuration	Writes the configuration data into the Intelligent Tap. If the sensor is being connected, the configuration data are written in the Intelligent Tap and sensor simultaneously.
	Configuration List	Shows a list of parameters.
	Safety distance calculation	Starts the safety distance calculation screen.
	Top Page	Returns to the top page from each screen.
	Load Default Layout	Brings the changed layout back to the initial state.
	Login	Starts the login screen.
	Logout	Logs out. Changes the access level from administrator to operator
	Change Password	Starts the change password screen.
	Clear Password	Starts the clear password screen.
	About	Starts the version information confirmation screen of SD Manager 3.
	Select Language	The operator selects a language. Select a language used from the dropdown list.

4-2-3-3. Displaying/Hiding Docked Windows

You can hide and display the [System Information], [Menu] and [Tool Message] windows. Click the Pin  button on the [System Information], [Menu] or [Tool Message] window.

The window is hidden a Show/Hide Tab is displayed on the left side of the screen.

To display the window again, click the Show/Hide Tab and then click the horizontal Pin button.

4-2-3-4. Shutting Down

To shut down SD Manager 3, click the x mark in the top right corner of the top page or click the [Exit]  button of the tool menu.

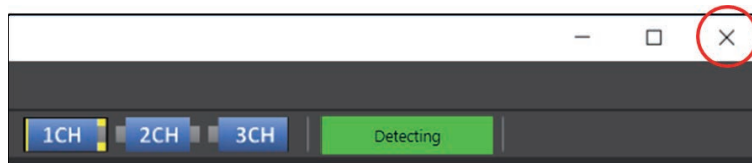

4-2-4. Starting SD Manager 3 Offline

4-2-4-1. Creating New Configuration File

You can create a configuration file when the F3SG-SR/PG is not connected to the PC (or offline).

Start SD Manager 3 offline and click the [New] button  on the tool menu.

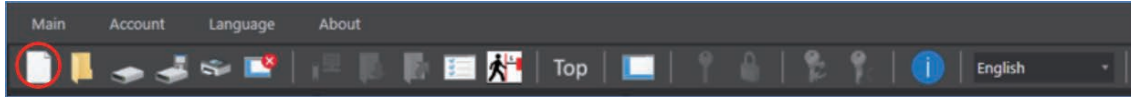

The following dialog is displayed.

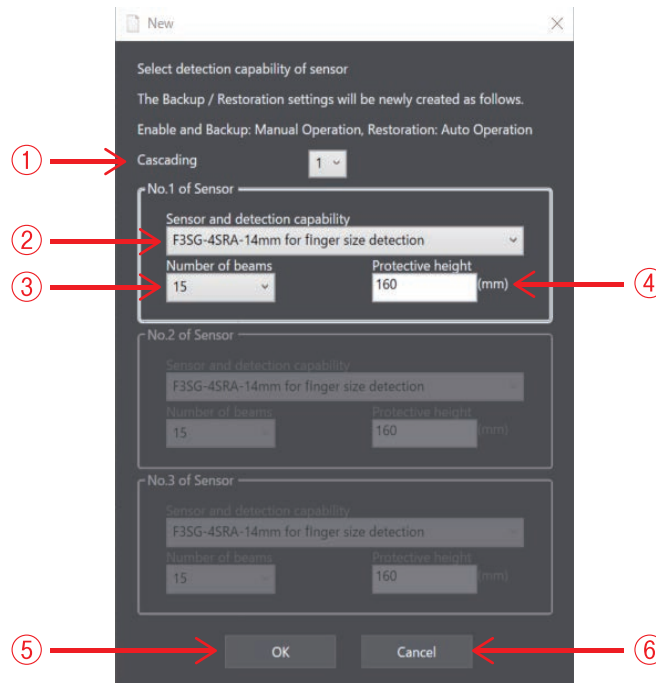

No.	Function	Description
1	Cascading	Select the number of cascaded sensors.
2	Sensor and Mos	For F3SG-SR/PG, select the sensor model and detection capability. *1
3	Number of beams	Select the desired number of beams from the drop-down list. The protective height is changed automatically according to the number of beams selected. *2
4	Protective height	Displays the protective height of the sensor.
5	OK	Enables SD Manager 3 to create a configuration file according to the settings made.
6	Cancel	Cancels the creation of a new file.

*1. To newly make configuration data for the sensor with an option number appended to the model number, select the sensor's standard model number not including the option number.

*2. For the 4-beam models of F3SG-PG, a product line-up with different protective height is available even for the same number of beams. Select a protective height as scrolling the drop-down list of the number of beams so that the protective height compatible with the sensor used is displayed.



4-2-4-2. Reading Configuration from PC

You can read a configuration file saved on a PC into SD Manager 3.

Start SD Manager 3 offline and click the [Open] button  from the tool menu.

Select a desired configuration file (with extension .sdm3) saved on your PC.

4-2-4-3. Saving New Configuration File to PC

On the tool menu, click the [Save] button  or the [Save As] button  to save the file in an arbitrary location on the PC.

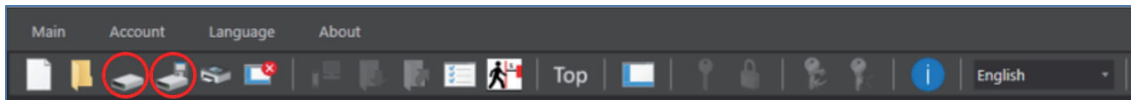

CHECK!

Save the created configuration data in the setting state or the offline state.

4-2-4-4. Switching Offline to Online

When you want to switch the offline state to the state where the F3SG-SR/PG is connected to the PC (or online state), shut down the SD Manager 3 and start it again. Select a COM port and click the [OK] button in the startup dialog window.



4-2-3-1. Getting Started

4-2-5. Logging In/Logging Out

4-2-5-1. Logging In

When reading or changing the configuration of the Intelligent Tap or F3SG-SR/PG using SD Manager 3, one of the following two access levels can be selected. Select the access level at which SD Manager 3 is used when logging in.

- Operator level: Only reading configuration information is available. (Only changing a power-on time and load switching frequency thresholds is available.)
- Administrator level: Reading and changing configuration information is available.

When an Intelligent Tap is connected with F3SG-SR/PG, if logging in, the F3SG-SR/PG shifts to the setting state and the safety output enters the OFF state.



The login operation can be executed even if position 2 of the DIP Switch on the Intelligent Tap is ON (DIP Switch Enabled).

CHECK!

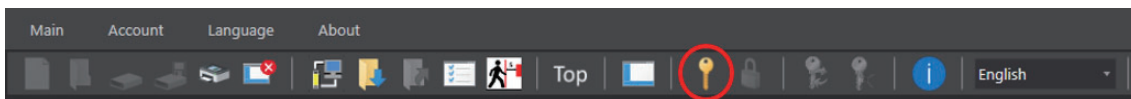

Select the [Login] button  from the [Account] menu on the tool bar.

Or, click the [Login] button  directly from the tool menu.

The following dialog is displayed.

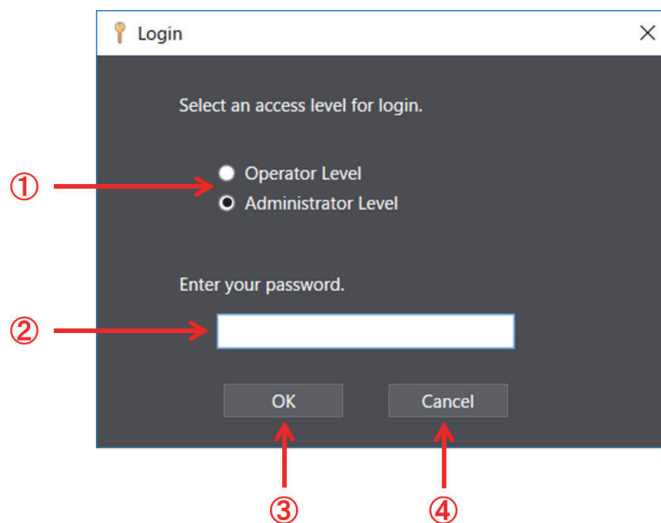

No.	Function	Description
1	Access level	Select either operator level or administrator level.
2	Enter your password	Enter a password if you want to log in with the administrator level.
3	OK	Enables the login at the selected level.
4	Cancel	Cancels the login.

- When logging in at the administrator level

Select the administrator level, enter the password, and click [OK].
The initial password is "0000".

- When logging in at the operator level

Select the operator level, and click [OK].

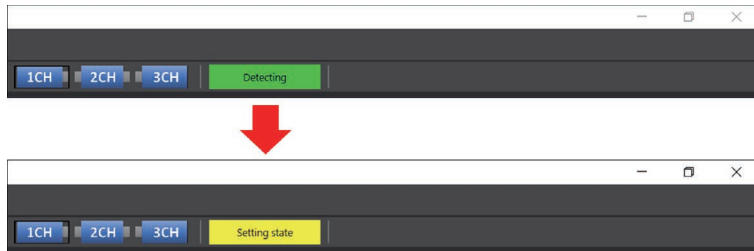

When connecting the Intelligent Tap to F3SG-SR/PG, and when login succeeds, the [Operating state] indication in the top right corner of the Top page is changed from [Detecting] to [Setting state].



CHECK!

When connecting the Intelligent Tap to a F3SG-SR/PG and trying to return the F3SG-SR/PG to [Detecting], follow step 4 of 4-1-3-2. *Connection Procedure When Using USB Connector* to restart the F3SG-SR/PG and Intelligent Tap, or click the [Monitor]  button.

4-2-5-2. Logging Out

In the login state at the administrator level, select the [Logout] button  from the [Account] menu on the tool bar or click .

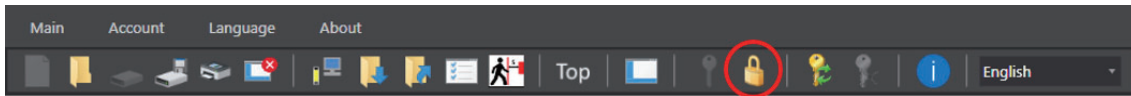

Access level is changed from the administrator level to the operator level.



It is not possible to log out using the operator level.

CHECK!



To bring F3SG-SR/PG back to the [Detecting] state, restart the F3SG-SR/PG and Intelligent Tap according to procedure 4 of 4-1-3-2. *Connection Procedure When Using USB Connector* or press the [Monitor] button .

CHECK!

4-2-6. Password Protection

4-2-6-1. Access Restriction

The administrator level requires a password to log in. The initial password for administrator login is "0000".

4-2-6-2. Changing Password

To prevent unintended configurations by an unauthorized user, the administrator must change the password. The password must contain no more than 6 alphanumeric characters. The password is case-sensitive.

To switch the password, restating the Intelligent Tap is necessary. Restart the Intelligent Tap according to procedure 4 of 4-1-3-2. *Connection Procedure When Using USB Connector*. The new password is enabled after the Intelligent Tap is restarted.

4-2-6-3. Forgot the Password?

If you forget the new password, let the Omron sales representative know the lot number printed on the Intelligent Tap. A clearing password to set the initial password "0000" again is issued.

 4-2-6-5. *Resetting the Initial Password to "0000"*

4-2-6-4. Confirming Lot No. of Intelligent Tap

■ Confirming with SD Manager 3

With the Intelligent Tap connected with the PC, start SD Manager 3.

You can check the lot number of the intelligent Tap on the [System Information] list on the left side of the top page.

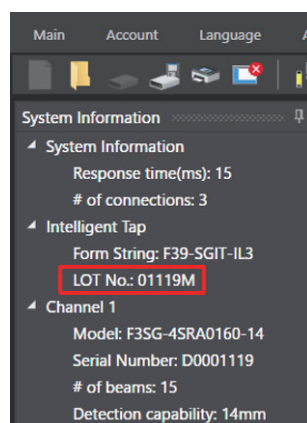



You can also check the lot number from the [Clear Password] window described in Step 3 below.

■ Confirming with Intelligent Tap

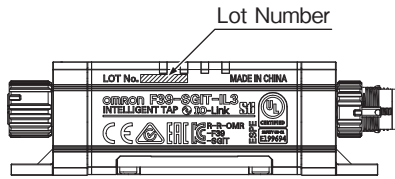
You can check the lot number of the Intelligent Tap from the marking on the Intelligent Tap body. See the figure below for the location of the marking.



4-2-6-5. Resetting the Initial Password to “0000”

1. Log in at the operator level. (No password is needed to log in at the operator level.)
 For login at the operator level, refer to 4-2-5-1. *Logging In*.
2. Select the [Clear Password] button  from the [Account] menu at the screen top of SD Manager 3. Or, click the [Clear Password] button  directly from the tool menu.
3. Fill in the clear password window with the clearing password provided by Omron and press OK. (A message saying that password initialization has succeeded is displayed on the [Tool Message] field at the screen bottom of SD Manager 3.)
4. It is necessary to restart the Intelligent Tap to switch the password. Restart the Intelligent Tap according to procedure 4 of 4-1-3-2. *Connection Procedure When Using USB Connector*. After the Intelligent Tap is restarted, the administrator password is brought back to “0000.”

4-2-7. Reading/Saving/Writing Configuration of Intelligent Tap

4-2-7-1. Reading Configuration from Intelligent Tap

Check that the Intelligent Tap is correctly connected and click the [Read configuration] button .

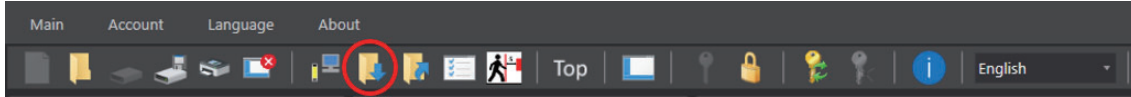

The configuration data are read by clicking this button. The read data can be confirmed on the setting screen of each function or using the [Configuration List] button .

It is able to move to a setting screen by clicking an icon of a function on the Top page.



For the display of each setting screen, refer to 4-3. *Changing Settings with SD Manager 3.*



For the way to save the configuration data in the Intelligent Tap: If saving a backup copy of the sensor settings in the Intelligent Tap, refer to 3-6-2. *Performing Backup.* If saving the configuration data created/edited using SD Manager 3 in the Intelligent Tap, refer to 4-2-7-3. *Writing Configuration into Intelligent Tap.*



CHECK!



When the F3SG-SR/PG is in the [Detecting] state, a dialog to confirm if it is OK to change mode is displayed. When OK is selected, the F3SG-SR/PG enters the Setting state (at the operator level). The safety outputs of the F3SG-SR/PG are turned to the OFF state.

4-2-7-2. Saving Configuration of Intelligent Tap in PC

Confirm that the Intelligent Tap is connected correctly.

Read the configuration saved in the Intelligent Tap according to the procedure of 4-2-7-1. *Reading Configuration from Intelligent Tap.*

Select the [Save] button  or the [Save As] button  from the [Main] menu on the tool bar to save the configuration in an arbitrary location on the PC.

Or, click the [Save] button  or the [Save As] button  directly from the tool menu to save the configuration in an arbitrary location on the PC.

4-2-7-3. Writing Configuration into Intelligent Tap

■ Writing Data Edited by SD Manager 3 into Intelligent Tap

Check that the Intelligent Tap is correctly connected and log in with the administrator level. Change the configuration of each function and click the [Write] button .

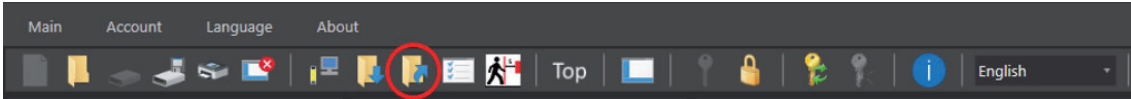

A Configuration List is displayed. The user can confirm the configuration information to be written to the F3SG-SR/PG.

When clicking the [Write] button  on the configuration list window:

■ F3SG-SR/PG Not Connected:

Configuration data can be written to the Intelligent Tap.

To write the configuration data written to the Intelligent Tap to the F3SG-SR/PG, refer to 3-6-3. *Performing Restoration* to perform restoration.

■ F3SG-SR/PG Connected:

Configuration data can be written to the Intelligent Tap and F3SG-SR/PG.

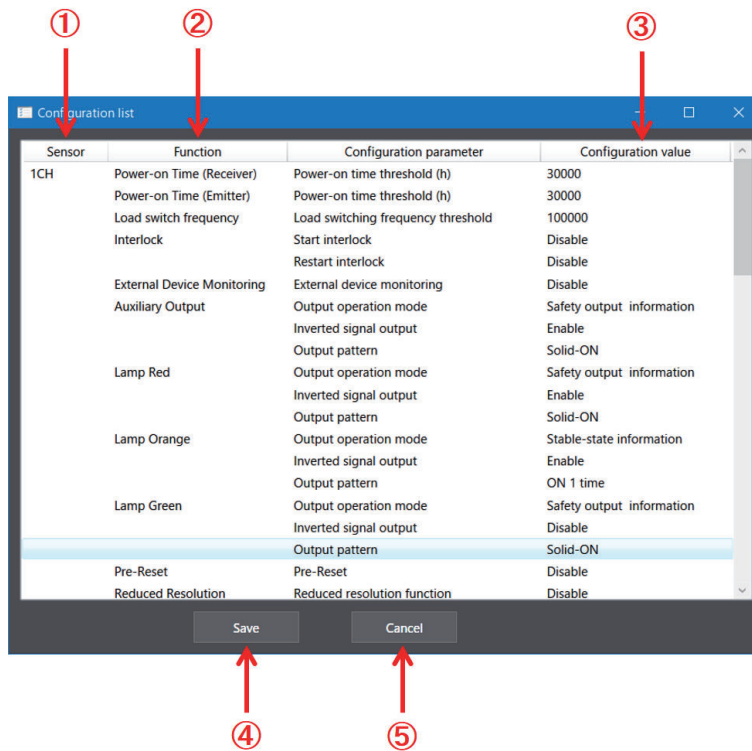

No.	Function	Description
1	Light Curtain	The target sensor segment to write the settings to is displayed.
2	Function	The function name is displayed.
3	Parameter	The parameters to be to be written to in the F3SG-SR/PG are displayed.
4	Save	Saves the parameters as a .csv file.
5	Cancel	Cancels the writing.



For operator and administrator levels, refer to 4-2-5. *Logging In/Logging Out.*



For the method to reflect the configuration data saved in the Intelligent Tap onto the sensor, refer to 3-6-3. *Performing Restoration.*



For reading of the configuration data saved in the Intelligent Tap, refer to 4-2-7-1. *Reading Configuration from Intelligent Tap.*





CHECK!

When connecting the Intelligent Tap to a F3SG-SR/PG and trying to return the F3SG-SR/PG to [Detecting], follow step 4 of 4-1-3-2. *Connection Procedure When Using USB Connector* to restart the F3SG-SR/PG and Intelligent Tap, or click the [Monitor]  button.

■ Writing Configuration File Saved in PC into Intelligent Tap

Check that the Intelligent Tap is correctly connected and log in with the administrator level.

By selecting the [Open] button  from the [Main] menu on the tool bar or clicking the [Open] button  directly from the tool menu, and select the configuration file (with extension sdm3) saved in an arbitrary location.

Click the [Write] button  to write the configuration.

■ F3SG-SR/PG Not Connected:

Configuration data can be written to the Intelligent Tap.

To write the configuration data written to the Intelligent Tap to the F3SG-SR/PG, refer to 3-6-3. *Performing Restoration* to perform restoration.

■ F3SG-SR/PG Connected:

Configuration data can be written to the Intelligent Tap and F3SG-SR/PG.



For operator and administrator levels, refer to 4-2-5-1. *Logging In.*



For the target sensor in the cascaded configuration of the F3SG-SR, refer to 4-2-3-2. *Description on Top Page and Each Button.*



For reading of the configuration file saved in the PC, refer to 4-2-4-2. *Reading Configuration from PC.*



CHECK!

When connecting the Intelligent Tap to a F3SG-SR/PG and trying to return the F3SG-SR/PG to [Detecting], follow step 4 of 4-1-3-2. *Connection Procedure When Using USB Connector* to restart the F3SG-SR/PG and Intelligent Tap, or click the [Monitor]  button.

4-2-8. Viewing Current Configuration

The current configuration list can be confirmed by clicking the [Configuration List] button  .

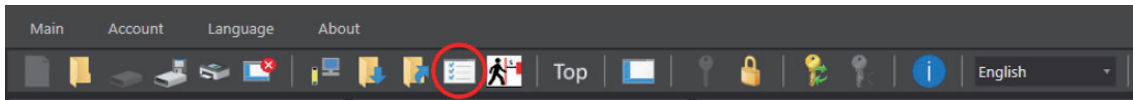

CHECK!

The configuration list can be confirmed even if position 2 of the DIP Switch on the Intelligent Tap is ON (DIP Switch Enabled).

4-2-9. Safety Distance Calculation

Click the [Safety Distance Calculation] button  from the [Main] menu on the tool bar or directly from the tool menu.

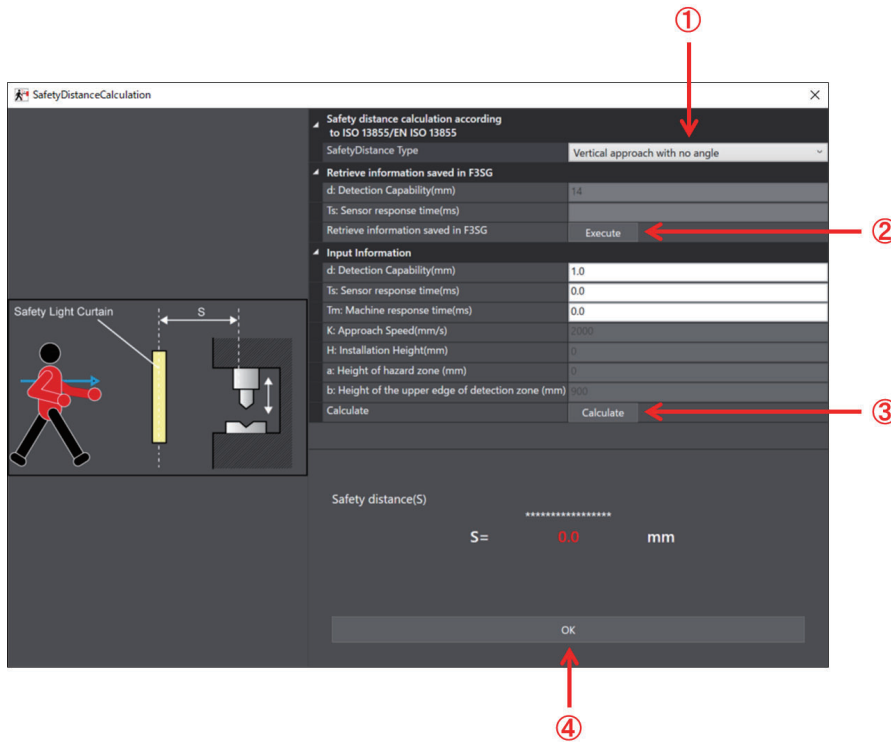

No.	Function	Description
1	Types of safety distance	Select a type of safety distance to be calculated.
2	Retrieve information from sensor	Update the data in [Input Information] to reflect the information in [Retrieve information stored in sensor].
3	Calculate	Calculates safety distance according to the specified condition.
4	OK	Closes the [Safety Distance Calculation] window.

 For safety distance, refer to 5-1-2. *Safety Distance*. The calculation is based on values entered in the screen.

 To calculate on the actually connected F3SG-SR/PG, execute [Retrieve information saved in F3SG] to update the numerical values.

CHECK!

4-3. Changing Settings with SD Manager 3



For F3SG-PGA-C, the number of the beams displayed is a half of that specified on the model.
For more information on the number of the beams specified for each model, refer to 1-6-1-2. *F3SG-PG Series*.

CHECK!

4-3-1. Preparing to Change Settings

To change settings, log in SD Manager 3 with the administrator level.

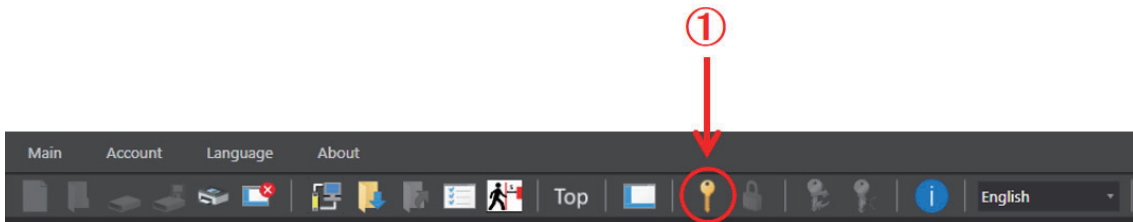

If configuring F3SG-SR in a cascade connection, select a target sensor segment to be configured.

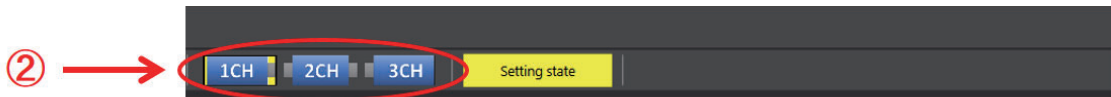

No.	Function	Description
1	Login	Shows the login screen.
2	Target sensor	Select a sensor to be configured. The selected target sensor is displayed in yellow.

For operator and administrator levels, refer to 4-2-5-1. *Logging In*.

For reading of configuration, refer to 4-2-7-1. *Reading Configuration from Intelligent Tap*.

To reflect each function setting described later to the Intelligent Tap, refer to 4-2-7-3. *Writing Configuration into Intelligent Tap*.

When connecting the Intelligent Tap to a F3SG-SR/PG and trying to return the F3SG-SR/PG to [Detecting], follow step 4 of 4-1-3-2. *Connection Procedure When Using USB Connector* to restart the F3SG-SR/PG and Intelligent Tap, or click the [Monitor] button.

CHECK!

4-3-2. I/O Settings

4-3-2-1. Interlock/External Device Monitoring (EDM)/PSDI

F3SG-SRA	✓	F3SG-PGA-A	△*1	F3SG-PGA-C	△*1
F3SG-SRB	✓	F3SG-PGA-L	△*1		

*1 The PSDI function is not supported.

First, carry out 4-3-1. *Preparing to Change Settings.*

Next, click the icon below on the Top page.

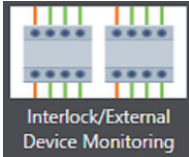

The setting screen below is displayed.

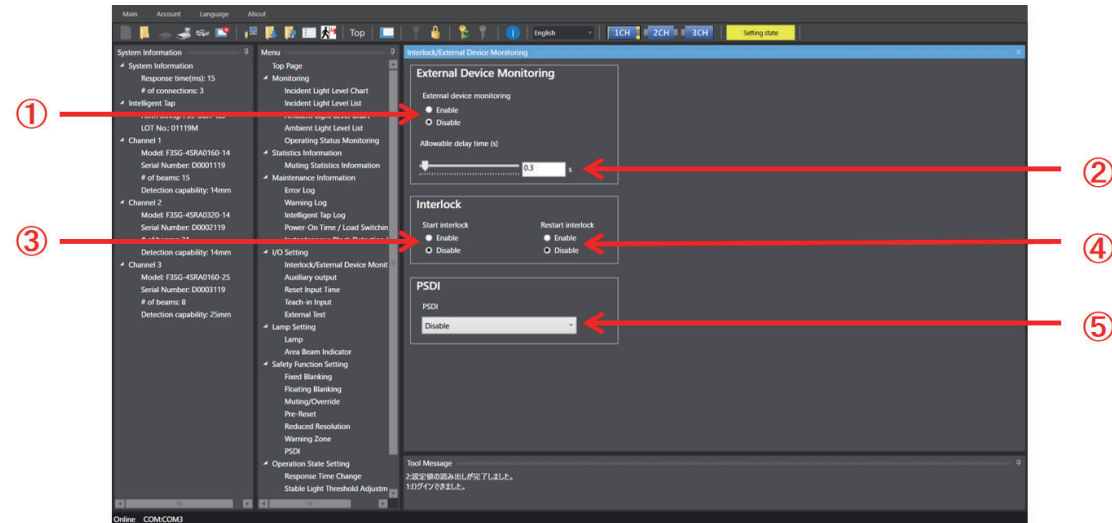

No.	Function name	Description	Initial value		Configurable value or numerical range
			Muting enabled *	Muting disabled *	
1	External device monitoring	Select Enable or Disable for the External Device Monitoring function.	Disable	Disable	Enable/Disable
2	Allowable delay time	Select desired delay time for the External Device Monitoring function.	0.3 s	0.3 s	0.1 to 4 s (in 0.1 s increments)
3	Start interlock	Select Enable or Disable for the Start Interlock function.	Disable	Disable	Enable/Disable
4	Restart interlock	Select Enable or Disable for the Restart Interlock function.	Disable	Disable	Enable/Disable
5	PSDI	Select Enable or Disable for PSDI function.	Disable	Disable	Disable/Single break /Double break

* For this function, setting parameters are kept individually in each case that the muting function is set enabled or disabled. When changing of the muting state from enabled to disabled or vice versa, confirm the setting of this function again.

For more information on function combinations, refer to Considerations for enabling and disabling Muting function with SD Manager 3 on 2-1. *Combination of Functions.*

- For more information on external relay monitoring, refer to 2-11. *External Device Monitoring (EDM).*
- For more information on start interlock and restart interlock, refer to 2-8. *Interlock.*
- For more information on the PSDI function and the compatible sensor models, refer to 2-10. *PSDI.*



When changing the settings is complete, confirm the settings and write the configuration to the F3SG-SR/PG. To enable the written configuration, refer to 4-2-7-3. *Writing Configuration into Intelligent Tap.*

CHECK!



When connecting the Intelligent Tap to a F3SG-SR/PG and trying to return the F3SG-SR/PG to [Detecting], follow step 4 of 4-1-3-2. *Connection Procedure When Using USB Connector* to restart the F3SG-SR/PG and Intelligent Tap, or click the [Monitor]  button.

CHECK!

4-3-2-2. Reset Input Time

F3SG-SRA	✓	F3SG-PGA-A	✓	F3SG-PGA-C	✓
F3SG-SRB	✓	F3SG-PGA-L	✓		

First, carry out 4-3-1. *Preparing to Change Settings.*

Next, on the Top page, click the icon below.

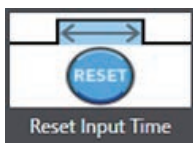

The setting screen below is displayed.

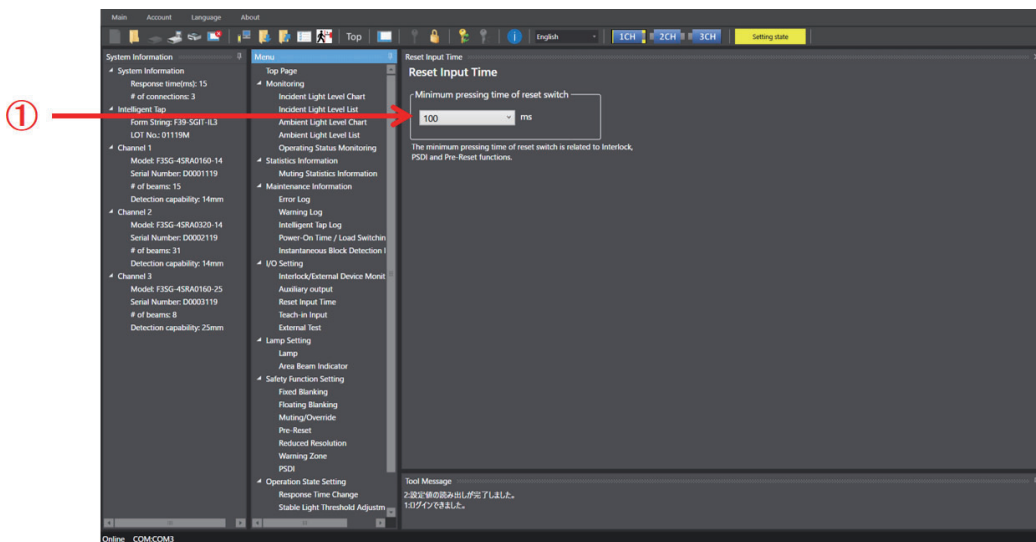

No.	Function name	Description	Initial value	Configurable value or numerical range
1	Minimum pressing time of reset switch	When using the manual reset function, set the minimum pressing time of reset switch. When using the pre-reset function, set the minimum pressing time of the reset switch and pre-reset switch. The same value is set on the pressing time of the reset switch and pre-reset switch. When using the PSDI function, set the minimum pressing time of the reset switch.	100 ms	100 to 500 ms (in 100 ms increments)



- For more information on manual reset, refer to 2-8. *Interlock.*
- For more information on pre-reset, refer to 2-9. *Pre-Reset.*
- For more information on PSDI, refer to 2-10. *PSDI.*



When changing the settings is complete, confirm the settings and write the configuration to the F3SG-SR/PG. To enable the written configuration, refer to 4-2-7-3. *Writing Configuration into Intelligent Tap.*

CHECK!



When connecting the Intelligent Tap to a F3SG-SR/PG and trying to return the F3SG-SR/PG to [Detecting], follow step 4 of 4-1-3-2. *Connection Procedure When Using USB Connector* to restart the F3SG-SR/PG and Intelligent Tap, or click the [Monitor]  button.

CHECK!

4-3-2-3. Teach-in Input

F3SG-SRA	✓	F3SG-PGA-A		F3SG-PGA-C	
F3SG-SRB	✓	F3SG-PGA-L			

First, carry out 4-3-1. *Preparing to Change Settings.*

Next, on the Top page, click the icon below.

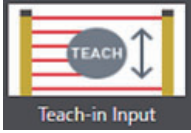

The setting screen below is displayed.

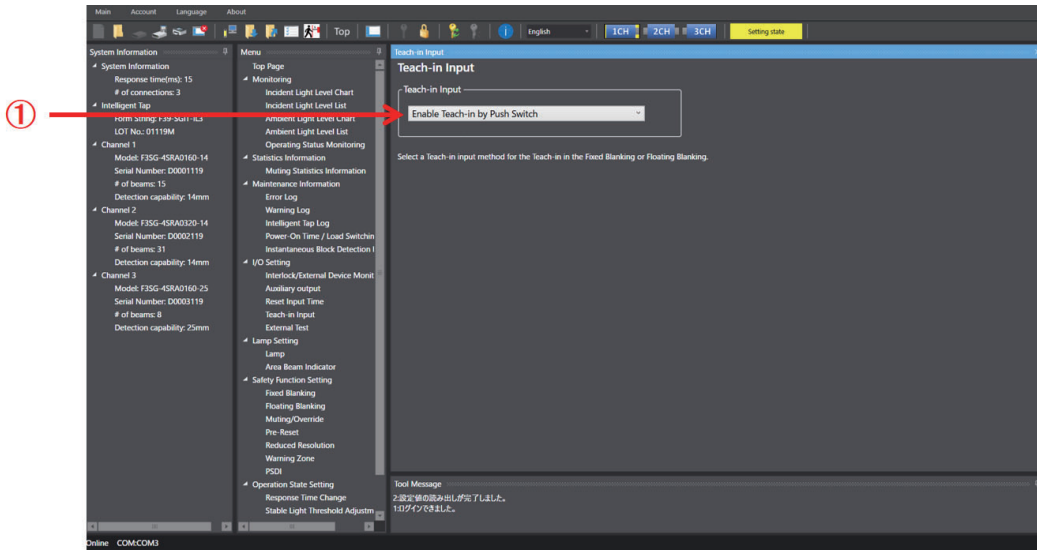

No.	Function name	Description	Initial value	Configurable value or numerical range
1	Teach-in Input	Select the method of the teach-in input when conducting teach-in of fixed blanking or floating blanking.	Enable Teach-in by Push Switch	Disable/Enable Teach-in by Push Switch/Enable Teach-in by Push Switch or wiring

For more information on teach-in, refer to 3-7. *Teach-in (Fix Blanking / Floating Blanking).*

When changing the settings is complete, confirm the settings and write the configuration to the F3SG-SR/PG. To enable the written configuration, refer to 4-2-7-3. *Writing Configuration into Intelligent Tap.*

CHECK!

When connecting the Intelligent Tap to a F3SG-SR/PG and trying to return the F3SG-SR/PG to [Detecting], follow step 4 of 4-1-3-2. *Connection Procedure When Using USB Connector* to restart the F3SG-SR/PG and Intelligent Tap, or click the [Monitor] button.

CHECK!

4-3-2-4. External Test Input

F3SG-SRA	✓	F3SG-PGA-A	✓	F3SG-PGA-C	
F3SG-SRB	✓	F3SG-PGA-L	✓		

First, carry out 4-3-1. *Preparing to Change Settings.*

Next, on the Top page, click the icon below.

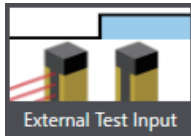

The setting screen below is displayed.

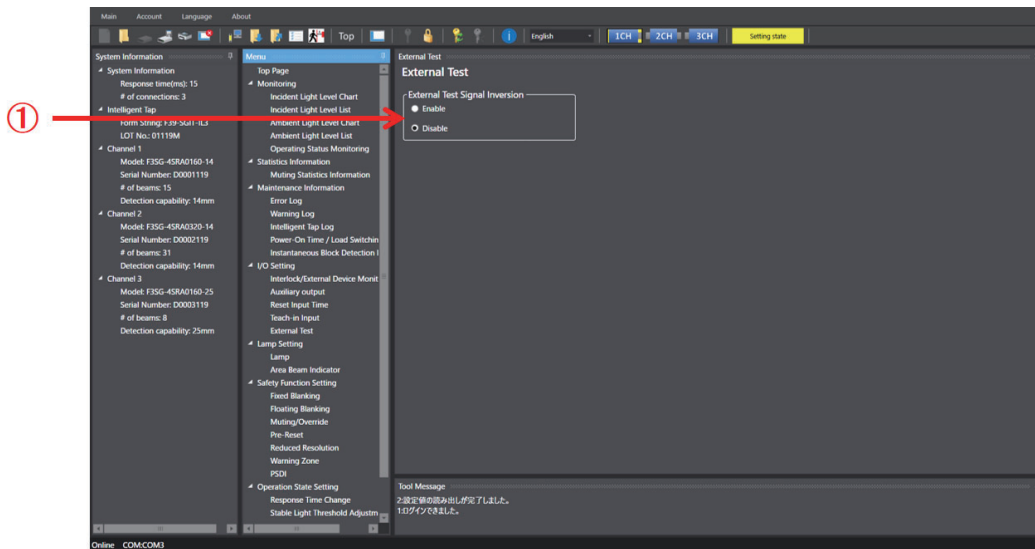

No.	Function name	Description	Initial value	Configurable value or numerical range
1	External Test Signal Inversion	Set either enable or disable of the external test signal inversion.	Disable	Enable/Disable

By setting either enable or disable of the external test signal inversion to PNP/NPN selection, the condition to stop emission can be selected. Refer to the table below.

External Test Signal Inversion *1	Input voltage	
	PNP setting *2	NPN setting *2
Disable (factory default setting)	Emission stops by connecting with 24 V connection.	Emission stops by connecting with 0 V connection.
Enable	Emission stops by connecting with 0 V connection.	Emission stops by connecting with 24 V connection.

*1. This can be set using SD Manager 3.

*2. This can be set by wiring.



For more information on external test signal inversion, refer to 2-6. *External Test.*



When changing the settings is complete, confirm the settings and write the configuration to the F3SG-SR/PG. To enable the written configuration, refer to 4-2-7-3. *Writing Configuration into Intelligent Tap.*

CHECK!



When connecting the Intelligent Tap to a F3SG-SR/PG and trying to return the F3SG-SR/PG to [Detecting], follow step 4 of 4-1-3-2. *Connection Procedure When Using USB Connector* to restart the F3SG-SR/PG and Intelligent Tap, or click the [Monitor]  button.

CHECK!

4-3-3. Auxiliary Output/Lamp Setting

4-3-3-1. Auxiliary Output/Lamp

F3SG-SRA	✓	F3SG-PGA-A	✓	F3SG-PGA-C	✓
F3SG-SRB	✓	F3SG-PGA-L	✓		

First, carry out 4-3-1. *Preparing to Change Settings.*

Next, click the icon below on the Top page.

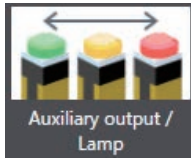

The setting screen below is displayed.

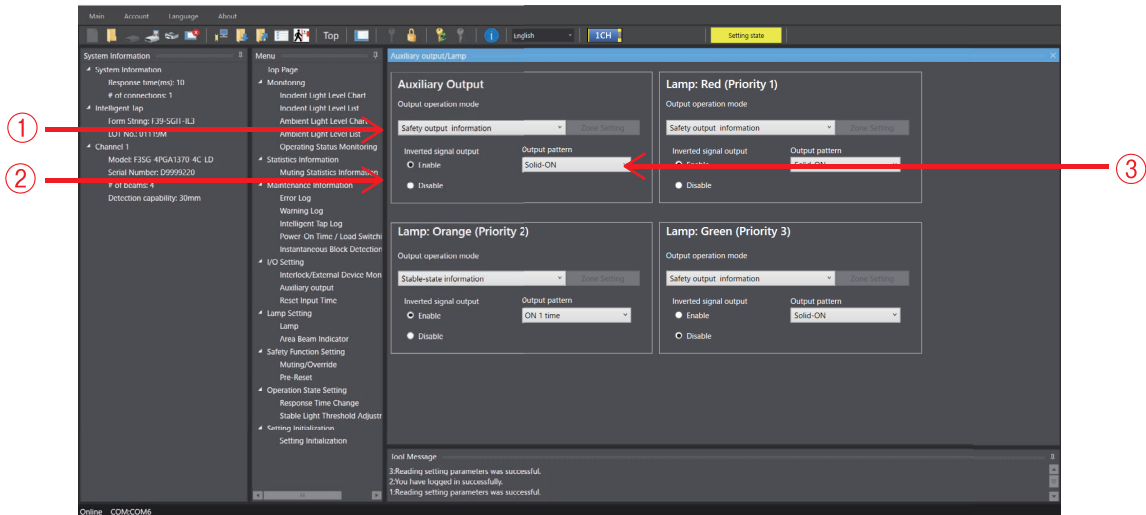

No.	Function name	Description	Initial value		Configurable value or numerical range Muting enabled *2
			Muting enabled *1	Muting disabled *2	
1	Output operation mode of auxiliary output/lamp	Select the information or signal output by the auxiliary output.	Safety output information	Safety output information	Information (Output operation mode) assigned to Auxiliary output/Lamp
2	Inverted signal output of auxiliary output/lamp	Select Enable or Disable for inverted signal of the auxiliary output.	Enable	Enable	Enable/Disable
3	Output pattern of auxiliary output/lamp	Select a desired output pattern of the auxiliary output.	Solid-ON	Solid-ON	Solid-ON/ON 1 time*2/ON 2 times*3/ON 3 times*3
4	Zone setting	Opens a zone setting screen for the Designated Beam Output function. The [Zone setting] button is only active when the [Designated beam output information] option is selected for the [Output operation mode]. CHECK!	For more information on settings, refer to 4-3-3-2. <i>Designated Beam Output.</i>		

*1 For this function, setting parameters are kept individually in each case that the muting function is set enabled or disabled. When changing of the muting state from enabled to disabled or vice versa, confirm the setting of this function again.

 For more information on function combinations, refer to Considerations for enabling and disabling Muting function with SD Manager 3 on 2-1. *Combination of Functions*.

*2 The auxiliary output is in the pattern described on ■ Timing chart in 2-12. *Auxiliary Output*.



 For more information on auxiliary output, refer to 2-12. *Auxiliary Output*.

*3 Only lamp can be selected. The auxiliary output is in the pattern described on ■ Output pattern chart in 2-26. *Lamp*.

 For further information on the lamp function, refer to 2-26. *Lamp*.

 When changing the settings is complete, confirm the settings and write the configuration to the F3SG-SR/PG. To enable the written configuration, refer to 4-2-7-3. *Writing Configuration into Intelligent Tap*.

CHECK!

 When connecting the Intelligent Tap to a F3SG-SR/PG and trying to return the F3SG-SR/PG to [Detecting], follow step 4 of 4-1-3-2. *Connection Procedure When Using USB Connector* to restart the F3SG-SR/PG and Intelligent Tap, or click the [Monitor]  button.

CHECK!

■ Information (Output operation mode) assigned to Auxiliary output/Lamp

Information Name	Description
Safety output information	When Safety output is in the ON state
Interlock information	Under INTERLOCK state
Lockout information	Under error/ LOCKOUT state
Excess power-on time information	When power-on time exceeds power-on time threshold
Excess load switching frequency information	When load switching frequency exceeds load switching frequency threshold
Stable-state information	When light intensity, which is constantly monitored, is 170% or higher (changeable *1) of ON-threshold
Muting information	Under Muting state
Override information	Under Override state
Muting/Override information	Under either Muting or Override state
Light level diagnosis information	When the F3SG-SR/PG is unblocked and light intensity is within a range from 100% to 170% of ON-threshold for 10 s or longer
Warning zone information *3	When warning zone is blocked
Blanking beam unblocked information *3	When Fixed-Blanking or Floating Blanking beams are unblocked
PSDI Information *3	When the F3SG-SR is ready to be blocked for feeding or removing parts
Troubleshooting support signal	When one of the signals of Sequence error information, Interference/vibration information and Light level diagnosis information is in the ON state.
Designated beam output information	When a designated beam is blocked or unblocked
Sequence error information	Under Muting sequence error state or Interlock sequence error state
Reset-input information	When Reset/EDM/Override input is in the ON state
Mute A input signal information	When muting input A is in the ON state
Mute B input signal information	When muting input B is in the ON state
EDM input information	When EDM signal input is in the ON state
Individual cascaded sensor output (Channel 1)	When Safety output of Primary sensor in cascade connection is the ON state
Individual cascaded sensor output (Channel 2) *2	When Safety output of 1st Secondary sensor in cascade connection is the ON state
Individual cascaded sensor output (Channel 3) *2	When Safety output of the 2nd Secondary sensor in cascade connection is the ON state
Blanking/Warning-zone information *3	When Fixed Blanking, Floating Blanking, Reduced Resolution or Warning Zone function is enabled
Instantaneous block information	When the F3SG-SR/PG stops accidentally due to interference or vibration. (In case of cascade connection, when any of cascaded segments comes under this condition.)
Pre-reset Information	Under Pre-reset state
Communication quality diagnosis information	Under communication retry state due to noise or communication cable short-circuit
Recoverable error information	Under recoverable error state
Replacement-recommended error information	Under replacement-recommended error state

Information Name	Description
None (OFF)	Disables the function.

- *1. This parameter can be changed using SD Manager 3. For details, refer to 4-3-5-2. *Stable Light Threshold Adjustment*.
- *2. The function can be configured even when no secondary sensor (Channel 2 or Channel 3) is connected. In that case, the safety outputs of the secondary sensor (Channel 2 or Channel 3) are regarded as the OFF state.
- *3. This is not supported by F3SG-PG.

4-3-3-2. Designated Beam Output

F3SG-SRA	✓	F3SG-PGA-A	✓	F3SG-PGA-C	✓
F3SG-SRB	✓	F3SG-PGA-L	✓		

First, carry out 4-3-1. *Preparing to Change Settings*.

Next, click the icon below on the Top page.

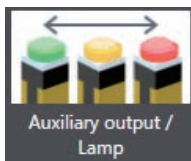

The setting screen below is displayed.

Select [Designated beam output information] for the output operation mode of the auxiliary output.

In the following example, the designated beam output information is assigned to the output operation mode of the auxiliary output.

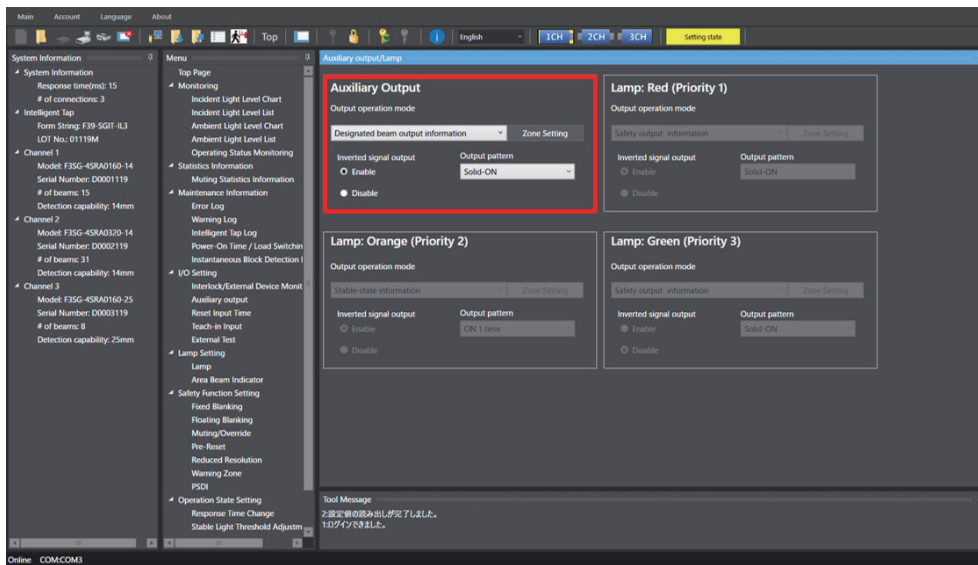

When [Designated beam output information] is selected for Output operation mode of Lamp at the same time, the area configured is the same for all these outputs.

Click the [Zone Setting] button to configure the designated beam output.

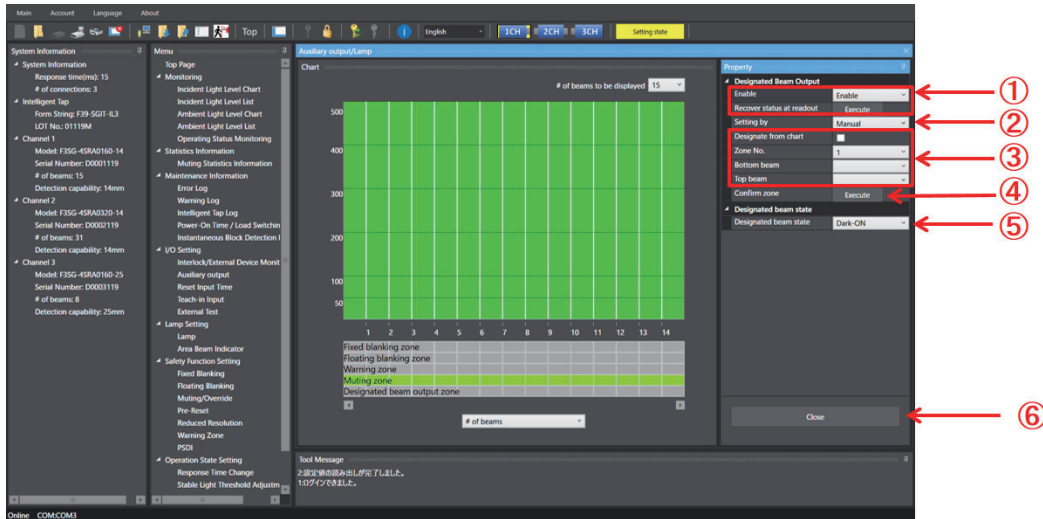

No.	Function name	Description	Initial value	Configurable item
1	Designated Beam Output	Select Enable or Disable for the Designated Beam Output function. When you want to restore the settings received from the F3SG, execute [Recover status at readout].	Disable	Enable/Disable
2	Setting by	Select manual setting using this software or setting by teach-in.	Manual	Manual/Teach-in
3	Zone setting	Select a desired zone number. To configure zone settings, specify desired bottom and top beam numbers from the drop-down list, or directly on the chart. When you check the [Designate from chart] box, you can specify a zone range by dragging red lines shown on the chart.	<ul style="list-style-type: none"> Bottom beam: Not specified Top beam: Not specified 	Desired beam (in 1-beam increments)
4	Confirm zone	To confirm the setting of the specified zone, execute [Confirm Zone].	-	-
5	Designated beam state	Select either Dark-ON or Light-ON.	Dark-ON	Dark-ON/Light-ON
6	Close	Returns to Auxiliary Output/Lamp setting.	-	-

Zone setting is possible for desired channel and beam (in 1-beam increments). The settings after the zone is determined are displayed in the zone information area under the chart.

CHECK!

For more information on designated beam output, refer to 2-23. *Designated Beam Output*.

When changing the settings is complete, confirm the settings and write the configuration to the F3SG-SR/PG. To enable the written configuration, refer to 4-2-7-3. *Writing Configuration into Intelligent Tap*.

CHECK!

When connecting the Intelligent Tap to a F3SG-SR/PG and trying to return the F3SG-SR/PG to [Detecting], follow step 4 of 4-1-3-2. *Connection Procedure When Using USB Connector* to restart the F3SG-SR/PG and Intelligent Tap, or click the [Monitor] button.

CHECK!

■ Designated Beam Output Setup Procedure

1. Set the output operation mode of the auxiliary output in [Designated beam output information], and press the [Zone Setting] button.
2. Enable the designated beam output function (No.1).
3. Set up the zone (Refer to ■ *Designated Beam Output Zone Setup Procedure* below.) (No. 2, 3, and 4).
4. Set up the designated beam unblocked state (No. 5).
5. Click the [Write configuration] button. On the settings list which will appear, confirm that the changed settings are correct, and click the OK button.

■ Designated Beam Output Zone Setup Procedure

Select a setup method (No. 2)

[Setting by Manual] (No. 3)

Select a zone No., and set up the bottom and top beam numbers.

Click the [Execute] button in [Confirm zone] to determine the designated beam output zone between the bottom and top beams configured above. (No. 4)

[Setting by Teach-in]

Selecting [Teach-in] switches the state to the Teach-in mode.

Block the F3SG-SR/PG in the zone that you wish to set up as the designated beam output zone.

Click the [Execute] button in [Confirm zone] to determine the designated beam output zone between the bottom and top beams blocked. (No. 4)

Select [Manual] in [Setting by] after the zone is determined (No. 2).

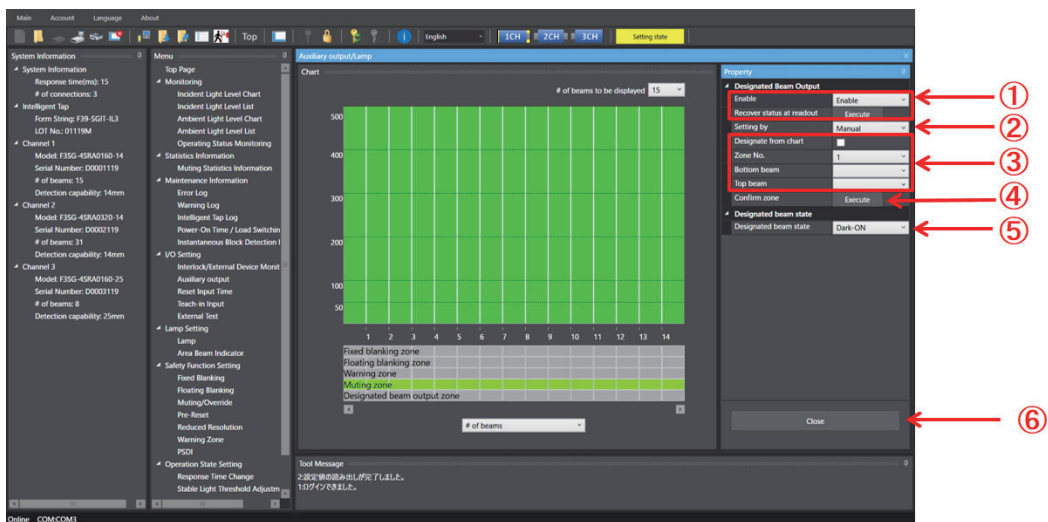

4-3-3-3. Area Beam Indicator (ABI)

F3SG-SRA	✓	F3SG-PGA-A	✓	F3SG-PGA-C	✓
F3SG-SRB		F3SG-PGA-L	✓		

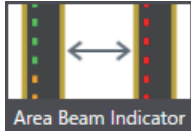

First, carry out 4-3-1. *Preparing to Change Settings.*

Next, on the Top page, click the icon below.

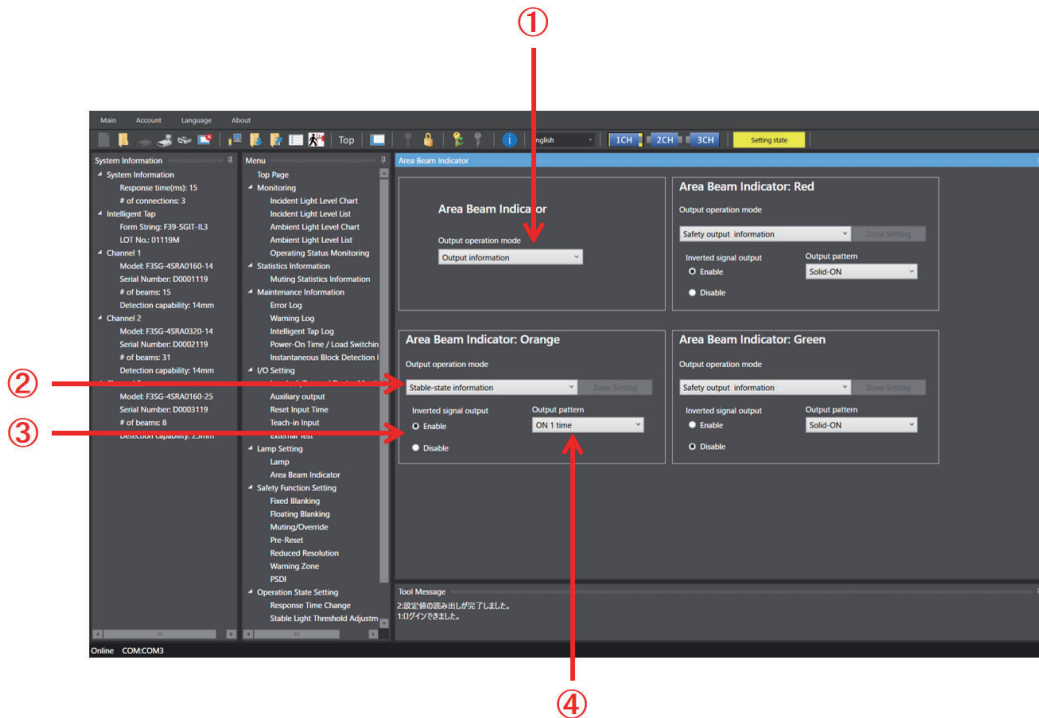

The setting screen below is displayed.



No.	Function name	Description	Initial value	Configurable value or numerical range	
1	Output operation mode of ABI	Select the operation mode of the area beam indicator (ABI).  Items 2 to 4 below can be set only when [Output Information] is selected. CHECK!	Block/Unblock Information	Disable/Block/Unblock Information/ Input signal linkage/Output information	
2	Output operation mode of ABI	Select the information/signal output by ABI.	Red	Safety output information	 For the information assigned to ABI, refer to Information (Output operation mode) assigned to Auxiliary output/Lamp of 4-3-3-1. <i>Auxiliary Output/Lamp.</i>
			Orange	Stable-state information	
			Green	Safety output information	
3	Inverted signal output of ABI pattern	Select Enable or Disable for the inverted setting of ABI patterns.	Red	Enable	Enable/Disable
			Orange	Enable	
			Green	Disable	
4	ABI output pattern	Select an ABI output pattern.	Red	Solid-ON	Illuminate/ON once/ON twice/ON three times
			Orange	ON 1 time	
			Green	Solid-ON	



CHECK!

Out of the three-color ABI patterns, if more than one type of signal information of the configured output operation mode occur simultaneously, the ABI illuminates in the ABI pattern color of the highest priority. (Priority high: red > orange > green: low)



For more information on area beam indicator (ABI), refer to 2-22. *Area Beam Indicator (ABI)*.



CHECK!

When changing the settings is complete, confirm the settings and write the configuration to the F3SG-SR/PG. To enable the written configuration, refer to 4-2-7-3. *Writing Configuration into Intelligent Tap*.



CHECK!

When connecting the Intelligent Tap to a F3SG-SR/PG and trying to return the F3SG-SR/PG to [Detecting], follow step 4 of 4-1-3-2. *Connection Procedure When Using USB Connector* to restart the F3SG-SR/PG and Intelligent Tap, or click the [Monitor]  button.

4-3-4. Safety Function Setting

4-3-4-1. Fixed Blanking

F3SG-SRA	✓	F3SG-PGA-A		F3SG-PGA-C	
F3SG-SRB	✓	F3SG-PGA-L			

First, carry out 4-3-1. *Preparing to Change Settings.*

Next, click the icon below on the Top page.

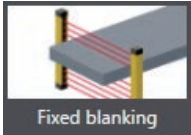

The setting screen below is displayed.

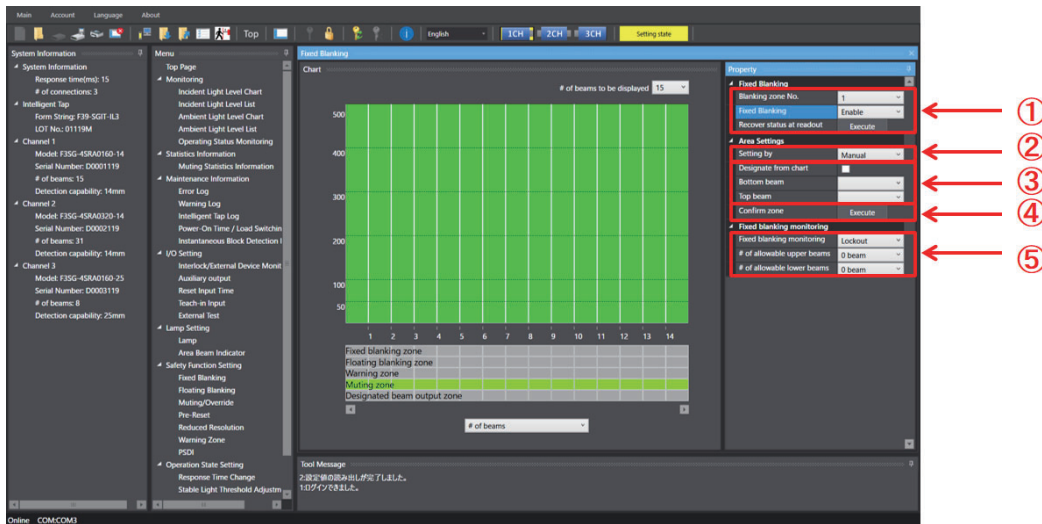

No.	Function name	Description		Initial value	Configurable value or numerical range
1	Blanking zone No.	This is the number for a target zone of the Fixed Blanking. Up to three fixed blanking zone can be configured for each channel.		1	1 to 3
	Fixed Blanking	Select Enable or Disable for the Fixed Blanking function for each fixed blanking zone. When you want to restore the readout settings received from the F3SG-SR/PG, click [Recover status at readout].		Disable	Disable/Enable
2	Setting by	Select manual setting using SD Manager 3 or setting by teach-in.		Manual/	Manual/Teach-in
3	Zone setting	To configure zone settings, specify desired bottom and top beam numbers from the drop-down list, or directly on the chart. When you check the [Designate from chart] box, you can specify a zone range by dragging red lines shown on the chart.		<ul style="list-style-type: none"> Bottom beam: Not specified Top beam: Not specified 	Desired beam (in 1-beam increments)
4	Confirm zone	To confirm the setting of the specified zone, execute [Confirm Zone].		-	-
5	Fixed blanking monitoring	Selected a desired monitoring method and number of allowable beams.	Fixed blanking monitoring	Lockout	Disable monitoring/ Lockout/Cancel blanking zone/Quick blanking
			Number of allowable upper/lower beams	0	0 to 5 beams (in 1-beam increments)



For more information on the Fixed Blanking, refer to 2-15. *Fixed Blanking*.



If using this function together with other functions, make settings taking the condition of adjacent zones into account.

CHECK!



For more information on zone adjacency conditions, refer to 2-19. *Setting Zone Adjacency Conditions*.



When changing the settings is complete, confirm the settings and write the configuration to the F3SG-SR/PG. To enable the written configuration, refer to 4-2-7-3. *Writing Configuration into Intelligent Tap*.

CHECK!



When connecting the Intelligent Tap to a F3SG-SR and trying to return the F3SG-SR to [Detecting], follow step 4 of 4-1-3-2. *Connection Procedure When Using USB Connector* to restart the F3SG-SR and Intelligent Tap, or click the [Monitor]  button.

CHECK!

■ Fixed Blanking Setup Procedure (Setting by Manual)

1. Select a Fixed Blanking zone, and enable the function (No. 1).
2. Set up the zone.
 - Select [Manual] in [Setting by]. (No. 2)
 - Set up the bottom and top beam numbers. (No. 3)
 - Click the [Execute] button in [Confirm zone] to determine the Fixed Blanking zone between the bottom and top beams configured above. (No.4)
3. Select a Fixed Blanking Monitoring function. (No. 5)
4. Set up the number of allowable beams. (No. 5)
 - The allowable beams are configurable inside the Fixed Blanking zone. The set allowable beams will be indicated in the chart as shown below.

Fixed blanking zone			
Floating blanking zone			
Warning zone			
Muting zone			
Designated beam output zone			

In this example, one upper and two lower beams are set as allowable beams.

The table below describes the number of allowable beams configurable for a Fixed Blanking zone.

Number of allowable beams available for fixed blanking beams

Number of fixed blanking beams	Maximum number of allowable beams
1	Setting not possible
2	1
3	2
4	3
n	n-1

5. Click the [Write configuration] button. On the settings list which will appear, confirm that the changed settings are correct, and click the [OK] button.

■ Fixed Blanking Setup Procedure (Setting by Teach-in)

1. Select a Fixed Blanking zone, and enable the function (No. 1).
2. Set up the zone.
 - Select [Teach-in] in [Setting by]. (No. 2)
 - Selecting [Teach-in] switches the state to the Teach-in mode.
 - Block the F3SG-SR/PG in the zone that you wish to set up as the Fixed Blanking zone.
 - Click the [Execute] button in [Confirm zone] to determine the Fixed Blanking zone between the bottom and top beams blocked. (No.4)
 - After the zone is determined, restore the [Setting by] to [Manual]. (No. 2)

3. Select a Fixed Blanking Monitoring function. (No. 5)

4. Set up the number of allowable beams. (No. 5)
 - The allowable beams are configurable inside the Fixed Blanking zone. The set allowable beams will be indicated in the chart as shown below.

Fixed blanking zone			
Floating blanking zone			
Warning zone			
Muting zone			
Designated beam output zone			

In this example, one upper and two lower beams are set as allowable beams.

The table below describes the number of allowable beams configurable for a Fixed Blanking zone.

Number of allowable beams available for fixed blanking beams

Number of fixed blanking beams	Maximum number of allowable beams
1	Setting not possible
2	1
3	2
4	3
n	n-1



When you wish to set allowable beams outside the blocked zone in Step 2, add a Fixed Blanking zone outside the zone determined in Step 2 and then set up allowable beams.

CHECK!

5. Click the [Write configuration] button. On the settings list which will appear, confirm that the changed settings are correct, and click the [OK] button.

4-3-4-2. Floating Blanking

F3SG-SRA	✓	F3SG-PGA-A		F3SG-PGA-C	
F3SG-SRB	✓	F3SG-PGA-L			

First, carry out 4-3-1. *Preparing to Change Settings.*

Next, click the icon below on the Top page.

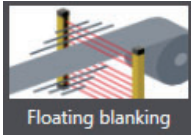

The setting screen below is displayed.

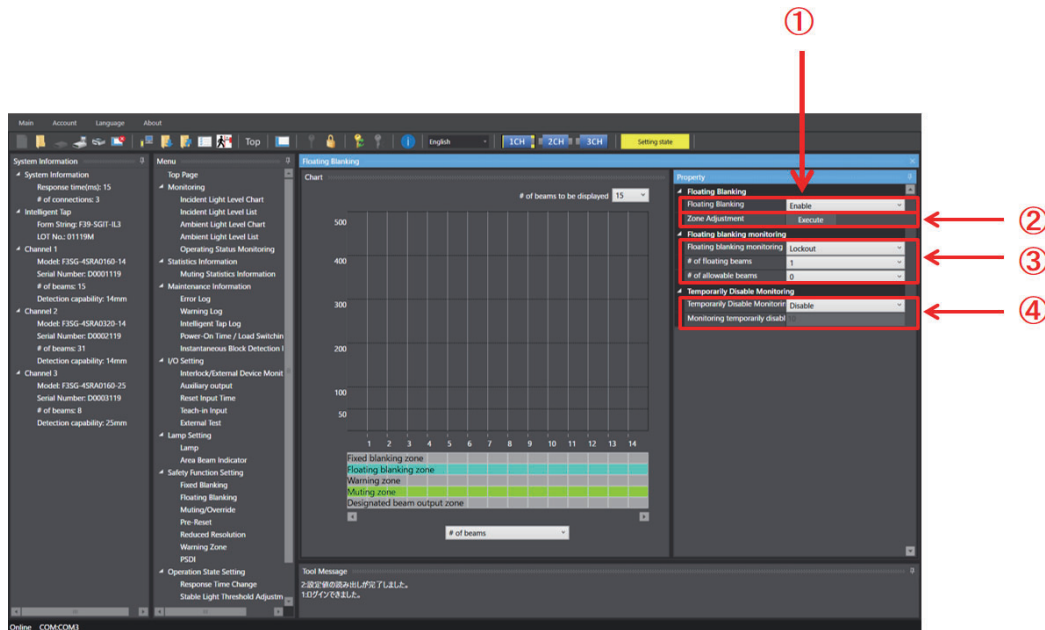

No.	Function name	Description		Initial value	Configurable value or numerical range
1	Floating Blanking Setting	Select Enable or Disable for the Floating Blanking function.		Disable	Disable/Enable
2	Zone Adjustment	Automatically adjusts a floating blanking zone setting when the setting is not correct.		-	-
3	Floating blanking monitoring	Set the floating blanking monitoring, number of floating beams, and number of allowable beams.	Floating blanking monitoring	Lockout	Disable monitoring / Lockout/ Cancel blanking Zone
			Number of floating beams	1	1 to 15 beams (in 1-beam increments)
			Number of allowable beams	0	0 to 5 beams (in 1-beam increments)
4	Temporarily Disable Monitoring	Select Enable or Disable for the Temporarily Disable Monitoring function and configure the Monitoring-temporarily-disabled time limit.	Temporarily disable monitoring	Disable	Disable/Enable
			Monitoring temporarily disabled time limit	10 s	0 to 200 s (in 1-s increments) (Infinite when 0 is set)

For more information on the Floating Blanking, refer to 2-16. *Floating Blanking.*

If using this function together with other functions, make settings taking the condition of adjacent zones into account.





For more information on zone adjacency conditions, refer to 2-19. *Setting Zone Adjacency Conditions*.



CHECK!

When changing the settings is complete, confirm the settings and write the configuration to the F3SG-SR/PG. To enable the written configuration, refer to 4-2-7-3. *Writing Configuration into Intelligent Tap*.



CHECK!

When connecting the Intelligent Tap to a F3SG-SR/PG and trying to return the F3SG-SR/PG to [Detecting], follow step 4 of 4-1-3-2. *Connection Procedure When Using USB Connector* to restart the F3SG-SR/PG and Intelligent Tap, or click the [Monitor]  button.

■ Floating Blanking Setup Procedure

1. Enable the Floating Blanking function (No. 1).
2. Set up the Floating Blanking function (No. 3).
3. Set up the number of floating beams (No. 3).
4. Set up the number of allowable beams (No. 3).
5. Set up the Temporarily Disable Monitoring function (No. 4).
When Enable is selected, also set up the monitoring-temporarily-disabled time limit (No. 4).



CHECK!

This function is only available when [Lockout] or [Cancel blanking zone] option is selected for the Floating Blanking Monitoring function.

6. Click the [Write configuration] button. On the settings list which will appear, confirm that the changed settings are correct, and click the [OK] button.

4-3-4-3. Muting/Override

F3SG-SRA	✓	F3SG-PGA-A	✓	F3SG-PGA-C	✓
F3SG-SRB	✓	F3SG-PGA-L	✓		

First, carry out 4-3-1. *Preparing to Change Settings.*

Next, click the icon below on the Top page.

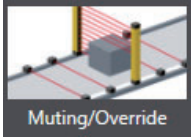

The setting screen below is displayed.

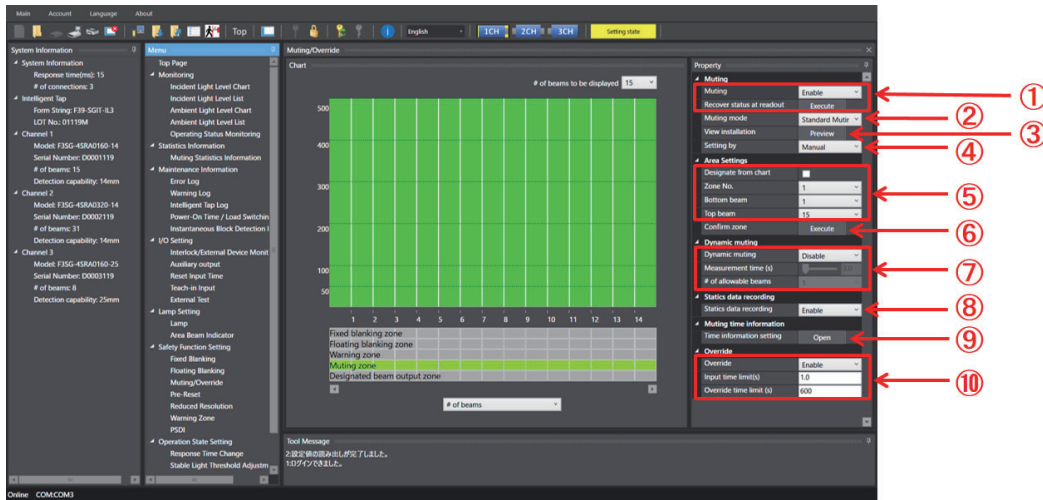

No.	Function name	Description	Initial value	Configurable value or numerical range
1	Muting	Select Enable or Disable for the Muting function. When you want to restore the readout settings received from the F3SG-SR/PG, execute [Recover status at readout].	Enable	Disable/Enable
2	Muting mode	Select a desired muting mode.	Standard Muting (Installation example 1)	Standard muting (Installation example 1)/Standard muting (Installation example 2)/Exit-only muting/Position detection muting
3	View installation	Shows installation conditions.	-	-
4	Setting by	Select manual setting using SD Manger 3 or setting by teach-in.	Manual	Manual/Teach-in
5	Zone setting	Select a desired zone number. To configure zone settings, specify desired bottom and top beam numbers from the drop-down list, or directly on the chart. When you check the [Designate from chart] box, you can specify a zone range by dragging red lines shown on the chart. In both cases above, execute [Confirm zone] to confirm the settings.	Bottom/Top beam: All beams	Desired beam (in 1-beam increments)
6	Confirm zone	Confirm the settings of the zone.	-	-

No.	Function name	Description	Initial value	Configurable value or numerical range	
7	Dynamic muting	Select Enable or Disable, measurement time and the number of allowable beams for the Dynamic Muting function. Set the measurement time by moving the pointer of the bar.	Dynamic muting	Disable	Disable/Enable
			Measurement time	3 s	1 to 25 s (in 0.1 s increments)
			Number of allowable beams	1	0 to 5 beams (in 1-beam increments)
8	Statistics data recording	Select Enable or Disable for recording of muting statistic data.	Enable	Disable/Enable	
9	Time information setting	Moves to the setting screen of muting time information.	-	-	
10	Override	Set Enable or Disable and time limit for overriding.	Override	Enable	Disable/Enable
			Override input time limit	1 s	0.1 to 5 s (in 0.1 s increments)
			Override time limit	600 s	0 to 600 s (in 1-s increments)/ (Infinite when 0 is set)



Zone setting is possible for desired channel and beam (in 1-beam increments).

The settings after the zone is determined are displayed in the zone information area under the chart.

CHECK!



- For more information on muting, refer to 2-13. *Muting*.
- For more information on override, refer to 2-14. *Override*.



For the following functions, the setting parameters are kept individually in each case that the muting function is set enabled or disabled. After changing the Muting function from Enable to Disable or from Disable to Enable, check the settings of these functions again.

CHECK!

Affected functions: External Device Monitoring (EDM), Start Interlock, Restart Interlock, Auxiliary Output



- For more information on the setting parameters, refer to:
- 2-8. *Interlock*
 - 2-11. *External Device Monitoring (EDM)*
 - 2-12. *Auxiliary Output*



When changing the settings is complete, confirm the settings and write the configuration to the F3SG-SR/PG. To enable the written configuration, refer to 4-2-7-3. *Writing Configuration into Intelligent Tap*.

CHECK!



When connecting the Intelligent Tap to a F3SG-SR/PG and trying to return the F3SG-SR/PG to [Detecting], follow step 4 of 4-1-3-2. *Connection Procedure When Using USB Connector* to restart the F3SG-SR/PG and Intelligent Tap, or click the [Monitor]  button.

CHECK!

■ Muting Setup Procedure

1. Enable the Muting function (No. 1).
2. Select a muting type (No. 2).
3. Set up a zone (Refer to ■ *Muting Zone Setup Procedure* below.) (Nos. 4, 5, and 6).
4. As needed, set up the Dynamic Muting function (No. 7).
5. As needed, set up the Statistics Data Recording function (No. 8).
6. Set up muting time information (Refer to ■ *Setting of Muting Time Information* below.) (No. 9).
7. As needed, set up the Override function (No. 10).
8. Click the [Write configuration] button. On the settings list which will appear, confirm that the changed settings are correct, and click the [OK] button.

■ Muting Zone Setup Procedure

Select a setup method (No. 4)

[Setting by Manual] (No. 5)

Select a zone No., and set up the bottom and top beam numbers.

Click the [Execute] button in [Confirm zone] to determine the muting zone between the bottom and top beams configured above. (No. 6)

[Setting by Teach-in]

Selecting [Teach-in] switches the state to the Teach-in mode.

Block the F3SG-SR/PG in the zone that you wish to set up as the muting zone.

Click the [Execute] button in [Confirm zone] to determine the muting zone between the bottom and top beams blocked. (No. 6)

Select [Manual] in [Setting by] after the zone is determined (No. 4).

■ Setting of Muting Time Information

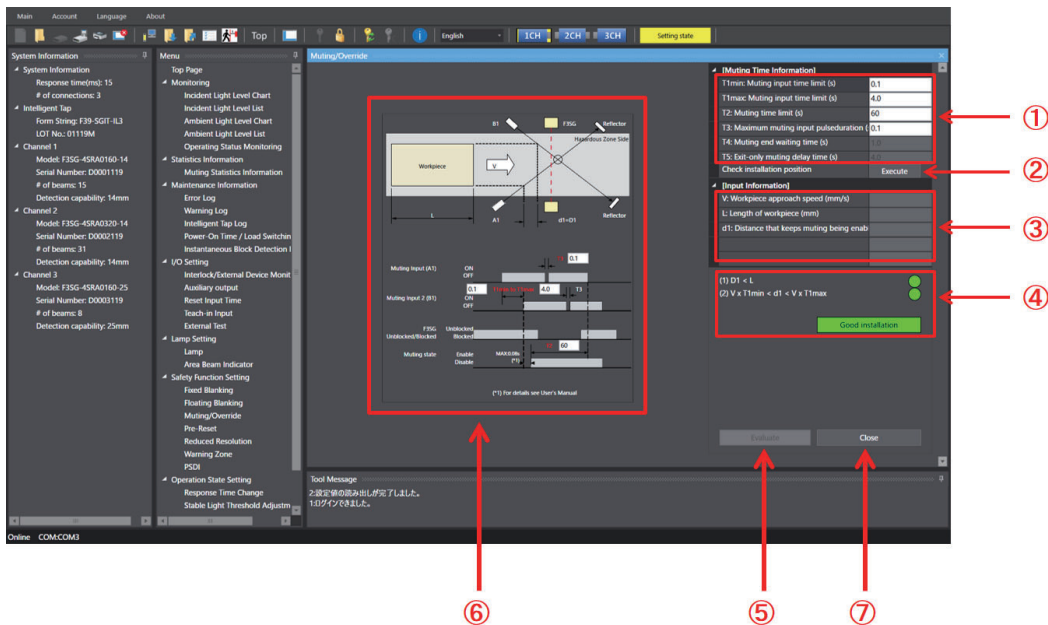

No.	Function name	Description	Initial value	Configurable value or numerical range	
1	Muting Time Information	Enter values of Muting-related time limits. For the Muting time input time limit and the Muting time limit, setting the value to zero means the time limit is infinite.	-	-	
		Standard muting	T1min: Muting input time limit (Min. value)	0.1 s	0.1 to 3.9 s (in 0.1 s increments)
			T1max: Muting input time limit (Max. value)	4 s	0.2 to 60 s (in 0.1 s increments)/infinite
			T2: Muting time limit	60 s	1 to 600 s (in 1 s increments)/infinite
			T3: Maximum allowable muting signal interruption	0.1 s	0.1 to 20 s (in 0.1 s increments)
		Exit-only muting	T1min: Muting input time limit (Min. value)	0.1 s	0.1 to 3.9 s (in 0.1 s increments)
			T1max: Muting input time limit (Max. value)	4 s	0.2 to 600 s (in 0.1 s increments)/infinite
			T2: Muting time limit	60 s	1 to 600 s (in 1 s increments)/infinite
			T3: Maximum allowable muting signal interruption	0.1 s	0.1 to 4 s (in 0.1 s increments)
			T4: Muting end waiting time	1 s	0.1 to 20 s (in 0.1 s increments)
		Position detection muting	T5: Exit-only muting delay time	4 s	4 to 20 s (in 0.1 s increments)
			T1max: Muting input time limit (Max. value)	4 s	0.2 to 60 s (in 0.1 s increments)/infinite
			T2: Muting time limit	60 s	1 to 600 s (in 1 s increments)/infinite
		T3: Maximum allowable muting signal interruption	0.1 s	0.1 to 4 s (in 0.1 s increments)	
2	Check installation position	Reflects the Muting Time Information settings to the timing chart shown in the left side of the screen, and allows data entry to the Input Information fields.	-	-	
3	Input Information	Enter information about the work-piece.	-	-	
4	Diagnosis of installation condition	It is diagnosed and displayed if the setting condition is appropriate.	-	-	
5	Evaluate	Checks if the muting with the entered settings is possible.	-	-	
6	Installation diagram and Timing chart	Shows the positions and timing chart of a work-piece, the F3SG-SR/PG and muting sensors. You can also make settings to the muting time information by editing the values in the timing chart directly.	-	-	
7	Close	Finishes the setting process of muting time information, and returns to muting setting.	-	-	



✓ If using this function together with other functions, make settings taking the condition of adjacent zones into account.

CHECK!



For more information on zone adjacency conditions, refer to 2-19. *Setting Zone Adjacency Conditions*.



When changing the settings is complete, confirm the settings and write the configuration to the F3SG-SR/PG. To enable the written configuration, refer to 4-2-7-3. *Writing Configuration into Intelligent Tap*.

CHECK!



When connecting the Intelligent Tap to a F3SG-SR/PG and trying to return the F3SG-SR/PG to [Detecting], follow step 4 of 4-1-3-2. *Connection Procedure When Using USB Connector* to restart the F3SG-SR/PG and Intelligent Tap, or click the [Monitor]  button.

CHECK!

■ Muting Time Information Setup Procedure

- 6-1** Enter [Muting Time Information] according to the setup state (No. 1).
- 6-2** Click [Installation Position Check] button (No. 2).
- 6-3** Enter [Input Information] according to the setup state (No. 3).
- 6-4** Click [Evaluation] to confirm the integrity of the entered condition (No. 5). The result is displayed in area 4.
If the result is Installation NG, review the entered condition above.
- 6-5** Click [Close] button (No. 7).



For more information on Muting Time Information (how to optimize T1), refer to 4-4-2. *Muting Statistics Information*.

4-3-4-4. Pre-Reset

F3SG-SRA	✓	F3SG-PGA-A	✓	F3SG-PGA-C	✓
F3SG-SRB	✓	F3SG-PGA-L	✓		

First, carry out 4-3-1. *Preparing to Change Settings.*

Next, click the icon below on the Top page.



The setting screen below is displayed.

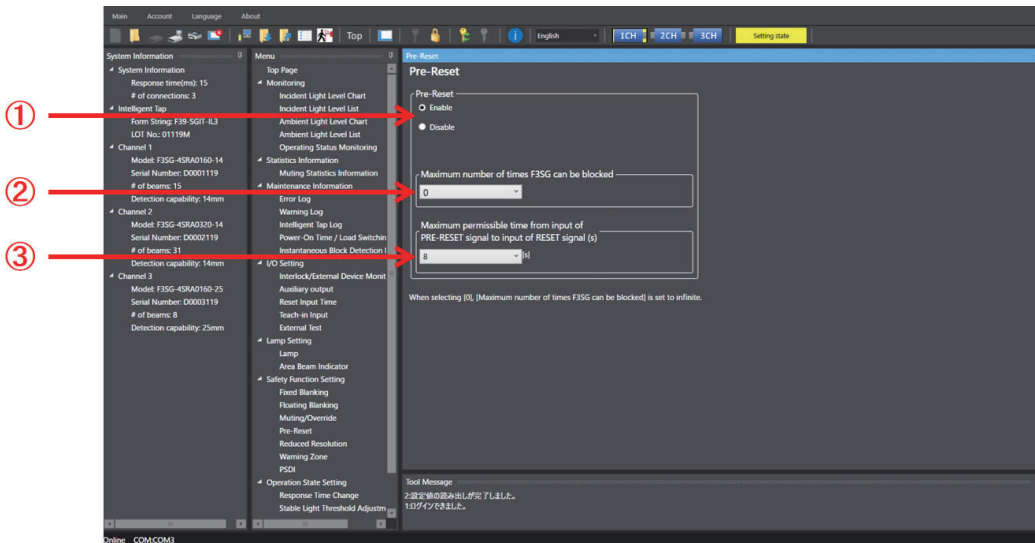

No.	Function name	Description	Initial value	Configurable value or numerical range
1	Pre-Reset function	Select Enable or Disable for the Pre-Reset function.	Disable	Enable/Disable *1
2	Maximum number of times F3SG-SR is blocked *2	Select desired maximum number the F3SG-SR can be blocked in the Pre-Reset process. The minimum number of times is 1. If you want to set this item to infinite, select zero.	0 (infinite)	0 to 9 times (in 1-time increments)
3	Maximum period of time from input of PRE-RESET signal to input of RESET signal	Select desired maximum time from inputting the PRE-RESET signal to inputting the RESET signal.	8 s	1 to 60 s (in 1s increments)

*1. When pre-reset is enabled, the pre-reset function takes priority, so the parameters of start interlock and restart interlock are ignored.

*2. The minimum number of times is fixed to one.



For more information on pre-reset, refer to.



It is not possible to configure the Pre-Reset function together with the Muting function. To enable settings of the Pre-Reset function, disable the Muting function. The setting parameters are kept individually in each case that the muting function is set enabled or disabled.

CHECK!

After changing the Muting function from Enable to Disable or from Disable to Enable, check the settings of these functions again.



Affected functions: External Device Monitoring (EDM), Start Interlock, Restart Interlock, Auxiliary Output

When changing the settings is complete, confirm the settings and write the configuration to the F3SG-SR.

To enable the written configuration, refer to 4-2-7-3. *Writing Configuration into Intelligent Tap.*

CHECK!



When connecting the Intelligent Tap to a F3SG-SR/PG and trying to return the F3SG-SR/PG to [Detecting], follow step 4 of 4-1-3-2. *Connection Procedure When Using USB Connector* to restart the F3SG-SR/PG and Intelligent Tap, or click the [Monitor]  button.

CHECK!

4-3-4-5. Reduced Resolution

F3SG-SRA	✓	F3SG-PGA-A		F3SG-PGA-C	
F3SG-SRB	✓	F3SG-PGA-L			

First, carry out 4-3-1. *Preparing to Change Settings*.
Next, click the icon below on the Top page.

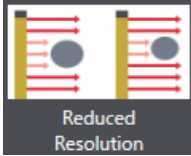

The setting screen below is displayed.

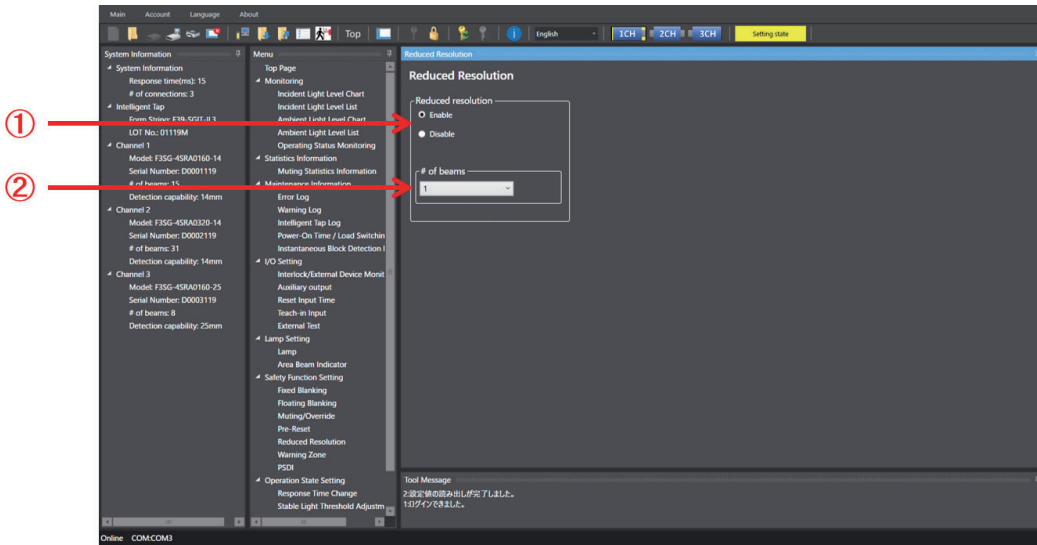

No.	Function name	Description	Initial value	Configurable value or numerical range
1	Reduced resolution	Select Enable or Disable for the Reduced Resolution function.	Disable	Enable/Disable
2	No. of beams	Select desired number of beams to be ignored. Up to three beams can be configured.	1	1 to 3 beams (in 1-beam increments)

For more information on reduced resolution, refer to 2-17. *Reduced Resolution*.
For more information on reduced resolution, refer to ■ Detection capability on 2-17. *Reduced Resolution*

It is not possible to configure the Reduced Resolution function together with the Muting function. To enable settings of the Reduced Resolution function, disable the Muting function.
CHECK! After changing the Muting function from Enable to Disable or from Disable to Enable, check the settings of these functions again.
Affected functions: External Device Monitoring (EDM), Start Interlock, Restart Interlock, Auxiliary Output

When changing the settings is complete, confirm the settings and write the configuration to the F3SG-SR/PG.
CHECK! To enable the written configuration, refer to 4-2-7-3. *Writing Configuration into Intelligent Tap*.

When connecting the Intelligent Tap to a F3SG-SR and trying to return the F3SG-SR to [Detecting], follow step 4 of 4-1-3-2. *Connection Procedure When Using USB Connector* to restart the F3SG-SR and Intelligent Tap, or click the [Monitor] button.
CHECK!

4-3-4-6. Warning Zone

F3SG-SRA	✓	F3SG-PGA-A		F3SG-PGA-C	
F3SG-SRB	✓	F3SG-PGA-L			

First, carry out 4-3-1. *Preparing to Change Settings.*

Next, click the icon below on the Top page.

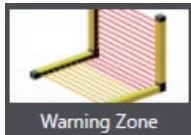

The setting screen below is displayed.

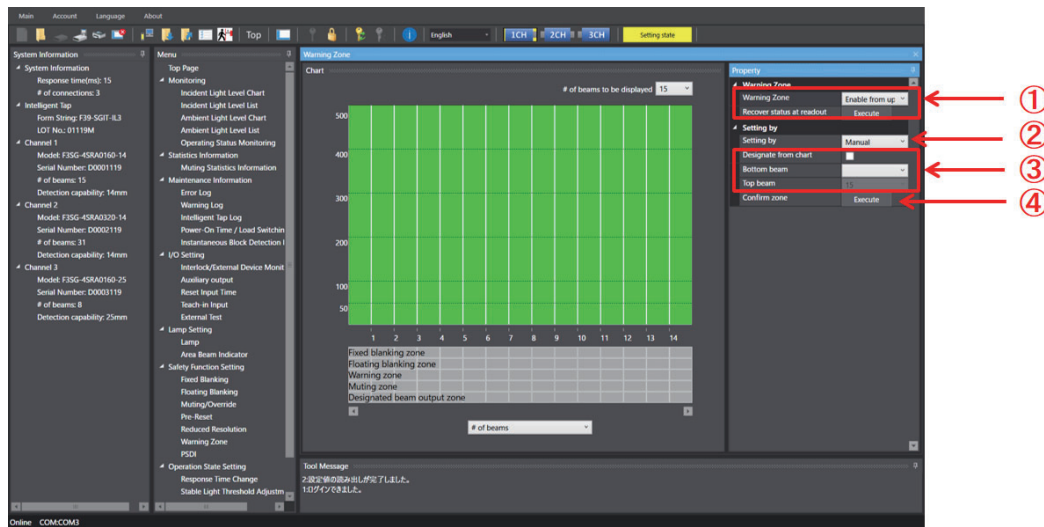

No.	Function name	Description	Initial value	Configurable value or numerical range
1	Warning Zone	Select Enable or Disable for the Warning Zone function. When you want to restore the readout settings received from the F3SG-SR/PG, click [Recover status at readout].	Disable	Disable/Enable from upper/Enable from lower
2	Setting by	Select either manual setup using SD Manager 3 or setup by teach-in.	Manual	Manual/Teach-in
3	Zone setting	To configure zone settings, specify desired bottom and top beam numbers from the drop-down list, or directly on the chart. When you check the [Designate from chart] box, you can specify a zone range by dragging red lines shown on the chart. In both cases above, execute [Confirm zone] to confirm the settings.	-	Desired beam (in 1-beam increments)
4	Confirm zone	Confirm the settings of the zone.	-	-

- For more information on warning zone, refer to 2-18. *Warning Zone.*
- If using this function together with other functions, make settings taking the condition of adjacent zones into account.
- CHECK!**
- For more information on zone adjacency conditions, refer to 2-19. *Setting Zone Adjacency Conditions.*
- When changing the settings is complete, confirm the settings and write the configuration to the F3SG-SR/PG. To enable the written configuration, refer to 4-2-7-3. *Writing Configuration into Intelligent Tap.*
- CHECK!**
- When connecting the Intelligent Tap to a F3SG-SR and trying to return the F3SG-SR to [Detecting], follow step 4 of 4-1-3-2. *Connection Procedure When Using USB Connector* to restart the F3SG-SR and Intelligent Tap, or click the [Monitor] button.
- CHECK!**

■ Warning Zone Setup Procedure

1. Enable the Warning Zone function (Details are described later) (No. 1).
2. Set up a zone (Details are described later) (Nos. 2, 3, and 4).
3. Click the [Write configuration] button. On the settings list which will appear, confirm that the changed settings are correct, and click the OK button.

■ Setup Procedure of the Function

- 1-1** The warning zone must include either a top or bottom beam of the F3SG.
- Enable from upper : The warning zone is enabled from the upper end.
 - Enable from lower : The warning zone is enabled from the bottom end.
 - Disable : The warning zone is disabled.

■ Setup Procedure of the Zone

- 2-1** Select a setup method (No. 2).
- [Manual setting] (No. 3)
 - When selecting [Enable from upper], set up the top beam.
 - When selecting [Enable from lower], set up the bottom beam.
 - [Teach-in]
 - When teach-in is selected, the software enters the teach-in mode.
 - When selecting [Enable from upper], block the lowest beam in the zone that you wish to specify as the warning zone.
 - When selecting [Enable from lower], block the top beam in the zone that you wish to specify as the warning zone.
- 2-2** Determine the zone (No. 4).
- When the zone has been selected by teach-in, select the Manual button again after the zone is determined (No. 2)

4-3-4-7. PSDI

F3SG-SRA	✓	F3SG-PGA-A		F3SG-PGA-C	
F3SG-SRB	✓	F3SG-PGA-L			

First, carry out 4-3-1. *Preparing to Change Settings.*

Next, click the icon below on the Top page.



The setting screen below is displayed.

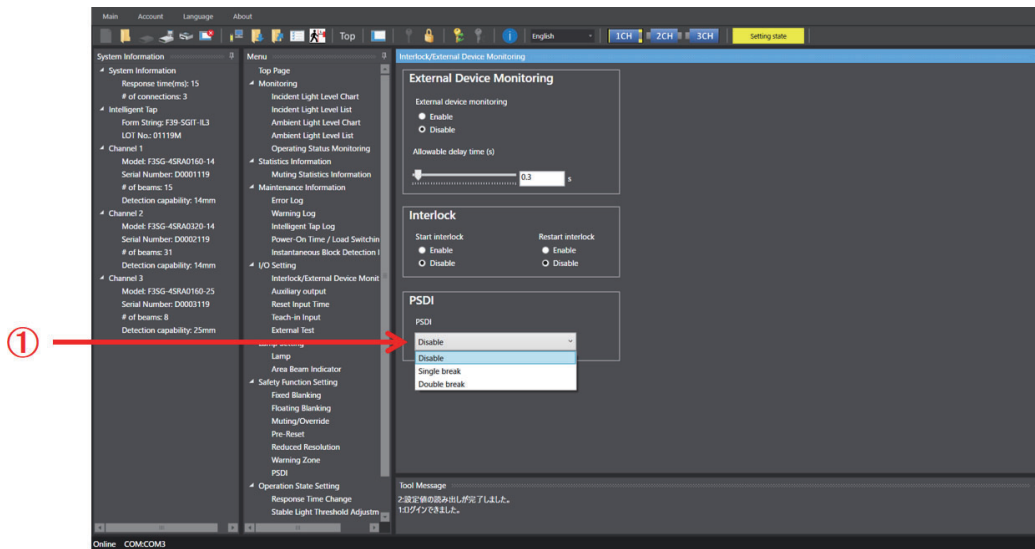

No.	Function name	Description	Initial value	Configurable value or numerical range
1	PSDI	Select disable, single break, or double break for the PSDI function.	Disable	Disable/Single break/Double break

For more information on PSDI, refer to 2-10. *PSDI.*

When changing the settings is complete, confirm the settings and write the configuration to the F3SG-SR/PG. To enable the written configuration, refer to 4-2-7-3. *Writing Configuration into Intelligent Tap.*

CHECK!

When connecting the Intelligent Tap to a F3SG-SR and trying to return the F3SG-SR to [Detecting], follow step 4 of 4-1-3-2. *Connection Procedure When Using USB Connector* to restart the F3SG-SR and Intelligent Tap, or click the [Monitor] button.

CHECK!

4-3-5. Operating State Setting

4-3-5-1. Response Time Change

F3SG-SRA	✓	F3SG-PGA-A	✓	F3SG-PGA-C	✓
F3SG-SRB	✓	F3SG-PGA-L	✓		

First, carry out 4-3-1. *Preparing to Change Settings*.

Next, click the icon below on the Top page.

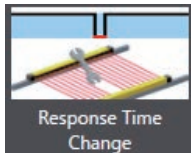

The setting screen below is displayed.

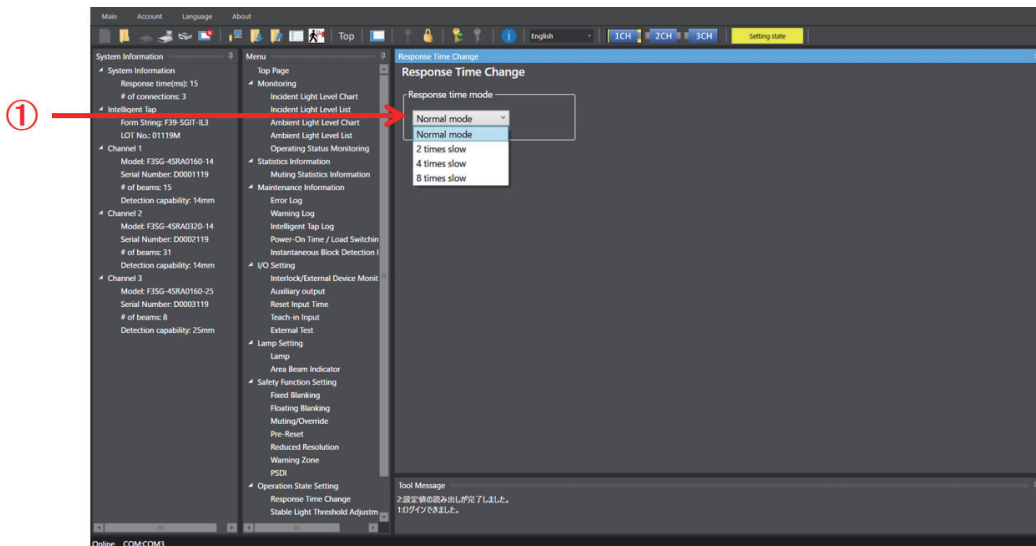

No.	Function name	Description	Initial value	Configurable value or numerical range
1	Response time mode	Select a desired mode of the response time.	Normal mode	Normal mode/2 times slow/4 times slow/8 times slow

For more information on response time adjustment, refer to 2-21. *Response Time Adjustment*.

When changing the settings is complete, confirm the settings and write the configuration to the F3SG-SR/PG. For more information on safety distance calculation, refer to 5-1-2. *Safety Distance*.

CHECK!

When changing the settings is complete, confirm the settings and write the configuration to the F3SG-SR. To enable the written configuration, refer to 4-2-7-3. *Writing Configuration into Intelligent Tap*.

CHECK!

When connecting the Intelligent Tap to a F3SG-SR/PG and trying to return the F3SG-SR/PG to [Detecting], follow step 4 of 4-1-3-2. *Connection Procedure When Using USB Connector* to restart the F3SG-SR/PG and Intelligent Tap, or click the [Monitor] button.

CHECK!

4-3-5-2. Stable Light Threshold Adjustment

F3SG-SRA	✓	F3SG-PGA-A	✓	F3SG-PGA-C	✓
F3SG-SRB	✓	F3SG-PGA-L	✓		

First, carry out 4-3-1. *Preparing to Change Settings.*

Next, on the Top page, click the icon below.

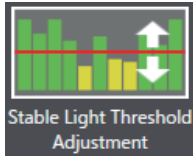

The setting screen below is displayed.

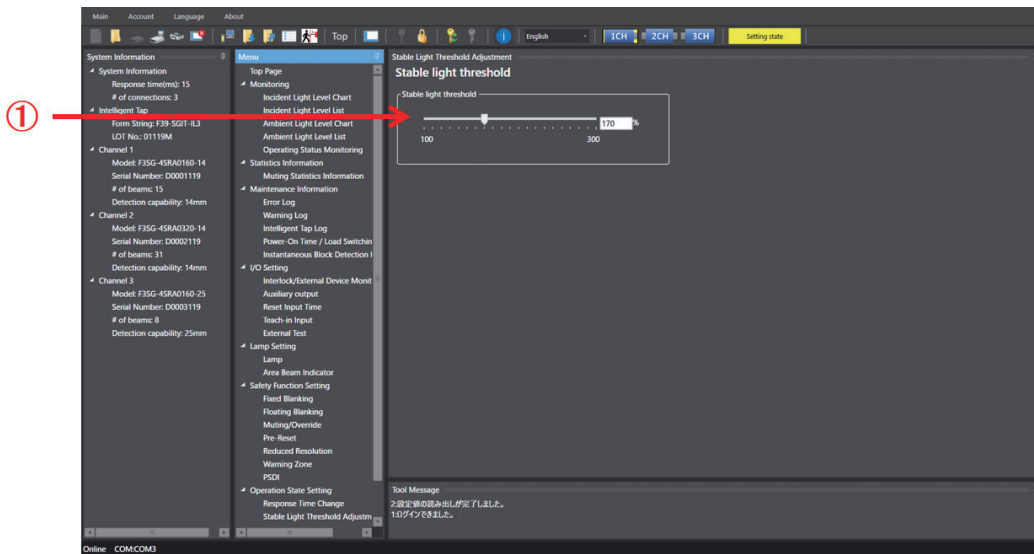

No.	Function name	Description	Initial value	Configurable value or numerical range
1	Stable light threshold	Set stable light threshold. Set the parameter by moving the pointer of the bar.	170%	100 to 300%

For more information on stable light threshold adjustment, refer to 2-24. *Stable Light Threshold Adjustment.*

When the stable light threshold value is changed, the following threshold values of the output information are also changed.

- CHECK!
- Auxiliary Output: Stable-state information and Light level diagnosis information (upper limit)
 - Area Beam Indicator: Stable-state information and Light level diagnosis information (upper limit)
 - IO-Link Process Data: Light level diagnosis information (upper limit)

When changing the settings is complete, confirm the settings and write the configuration to the F3SG-SR/PG. To enable the written configuration, refer to 4-2-7-3. *Writing Configuration into Intelligent Tap.*

CHECK!

When connecting the Intelligent Tap to a F3SG-SR/PG and trying to return the F3SG-SR/PG to [Detecting], follow step 4 of 4-1-3-2. *Connection Procedure When Using USB Connector* to restart the F3SG-SR/PG and Intelligent Tap, or click the [Monitor] button.

CHECK!

4-3-5-3. Operating Range Selection

F3SG-SRA	✓	F3SG-PGA-A		F3SG-PGA-C	
F3SG-SRB	✓	F3SG-PGA-L	✓		

First, carry out 4-3-1. *Preparing to Change Settings.*

Next, on the Top page, click the icon below.

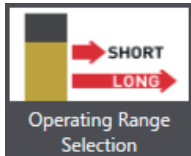

The setting screen below is displayed.

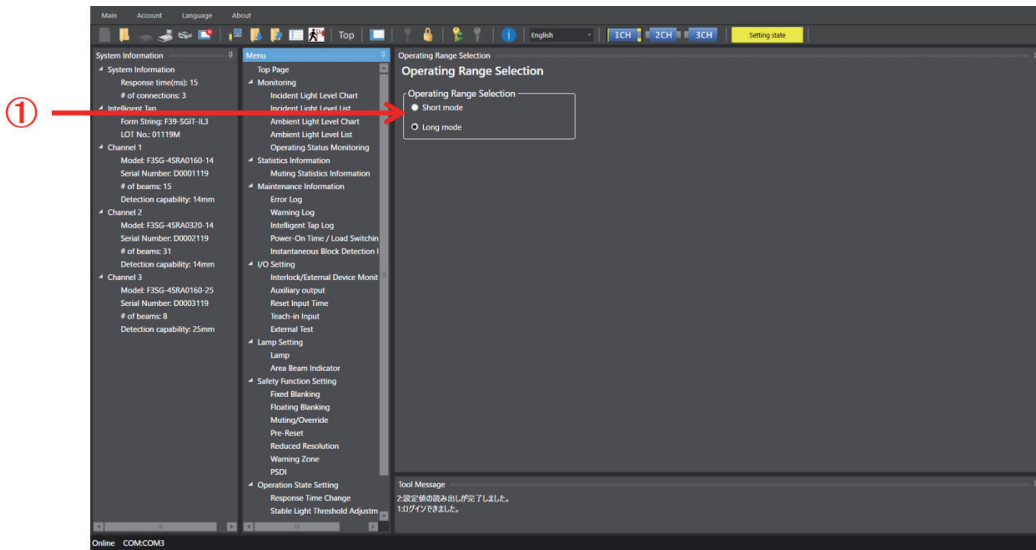

No.	Function name	Description	Initial value	Configurable value or numerical range
1	Operating Range Selection	Select the operating range.	Long mode	Short mode/Long mode

For more information on operating range selection, refer to 2-20. *Operating Range Selection.*

If the emitter is not connected to the Intelligent Tap, you can configure the Operating Range Selection using SD Manager 3.

CHECK!

Under the optical synchronization setting, the operating range is determined by the wiring of the operating range selection input line.

CHECK!

When changing the settings is complete, confirm the settings and write the configuration to the F3SG-SR/PG. To enable the written configuration, refer to 4-2-7-3. *Writing Configuration into Intelligent Tap.*

CHECK!

When connecting the Intelligent Tap to a F3SG-SR/PG and trying to return the F3SG-SR/PG to [Detecting], follow step 4 of 4-1-3-2. *Connection Procedure When Using USB Connector* to restart the F3SG-SR/PG and Intelligent Tap, or click the [Monitor] button.

CHECK!

4-3-6. Setting Initialization

This function is usable to bring the settings of each function back to the factory default settings. Log in at the administrator level and click the icon below on the top page.



The setting screen below is displayed.

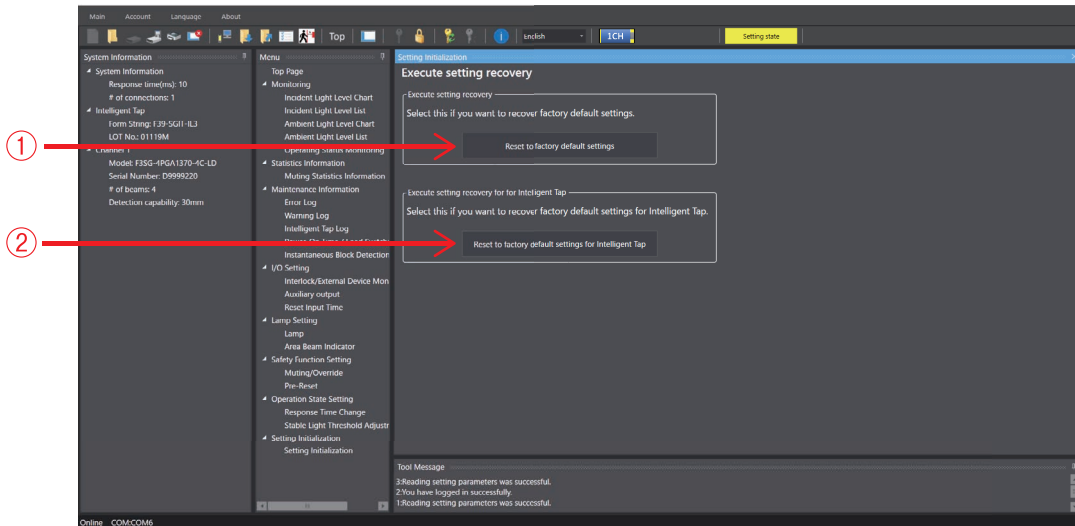

4-3-6-1. Initializing F3SG-SR/PG Settings

F3SG-SRA	✓	F3SG-PGA-A	✓	F3SG-PGA-C	✓
F3SG-SRB	✓	F3SG-PGA-L	✓		

In order to execute setting initialization, click [Reset to factory default settings].



■ In a cascade connection of F3SG-SR

Select the channel of the F3SF-SR sensor you wish to bring back to the factory default settings using the [Target Sensor] button **1CH 2CH 3CH** in the top right corner of the screen, and click [Reset to factory default settings].

To bring all the cascaded channels back to the factory default settings, execute setting initialization for each channel.

■ With F3SG-SR/PG connected, updating the backup settings of F3SG-SR/PG saved in the Intelligent Tap to the factory default settings

Initialize the settings of all the initialization target channels according to the procedure above. Then, click the [Write] button .

 Unless clicking the [Write] button , the backup settings of F3SG-SR/PG saved in the Intelligent Tap are not updated. In this state, if restarting the F3SG-SR/PG with the Position 1 of the DIP Switch set at ON (Lock), the F3SG-SR/PG is restored by the settings before initialization.

CHECK!

 Even after the settings are returned to the factory default settings, the password which has already been changed is not returned to initial password "0000." For the password, refer to 4-2-6. Password Protection.

CHECK!

4-3-6-2. Initializing Settings of Intelligent Tap (F39-SGIT-IL3)

To initialize the settings of the Intelligent Tap, use the following steps.

1. Set the Intelligent Tap DIP-SW as factory default settings. As shown below, set the DIP switch channel 1 as ON (lock) and channels 2 to 8 as OFF.

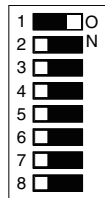

□: Indicates the switch position.

2. To initialize the settings of the Intelligent Tap, click [Restore Intelligent Tap factory default settings]([②](#)).



CHECK!

When the settings of the Intelligent Tap is initialized, the setting data of F3SG-SR/PG that were backed up in the Intelligent Tap is initialized. If the initialized Intelligent Tap is connected to F3SG-SR/PG and powered, the setting data of F3SG-SR/PG is automatically backed up in the Intelligent Tap. For how to Initialize the settings of the Intelligent Tap with the factory default settings, refer to 3-1-2. *Initial Setup Method after Purchase*.



CHECK!

Even if the factory default settings are restored, the changed password will not be reset to the initial password "0000". For details of password, refer to 4-2-6. *Password Protection*.

4-3-7. Backup/Restoration

First, execute 4-3-1. *Preparing to Change Settings*.
Next, click the following icon on the top page.

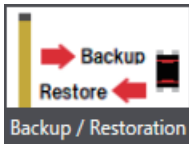

The following settings screen will be displayed.

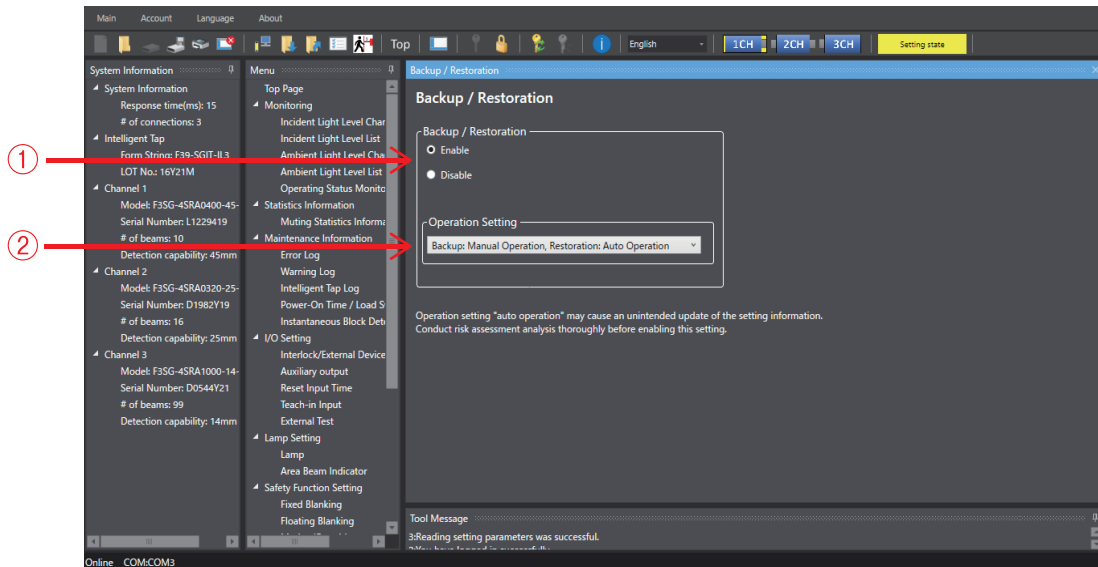

No.	Feature Name	Explanation	Default Value	Configurable Options
1	Backup/Restoration	Select whether to enable or disable the Backup/Restoration function.	Enable	Enable / Disable
2	Operation Settings	Select the operation method from the following options: Backup: Manual Operation, Restoration: Auto Operation / Backup: Manual Operation, Restoration: Manual Operation	Backup: Manual Operation, Restoration: Auto Operation	Backup: Manual Operation, Restoration: Auto Operation / Backup: Manual Operation, Restoration: Manual Operation

For the Backup/Restoration function, please refer to, please refer to 2-31. *Backup/Restoration*.

After completing the setting changes, please verify the settings for each function and execute the write operation.
For writing the setting data, please refer to 4-2-7-3. *Writing Configuration into Intelligent Tap*.

CHECK!

4-4. Monitoring with SD Manager 3



For F3SG-PGA-C, the number of the beams displayed is a half of that specified on the model.
For more information on the number of the beams specified for each model, refer to 1-6-1-2. *F3SG-PG Series*.

4-4-1. Monitoring

Logging in is not needed to perform the monitoring functions described in this section.

4-4-1-1. Incident Light/Ambient Light

This function can be used only when the F3SG-SR/PG is connected to the Intelligent Tap and a PC.
On the Top page, click the icon below.

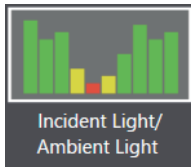

The screen below is displayed.

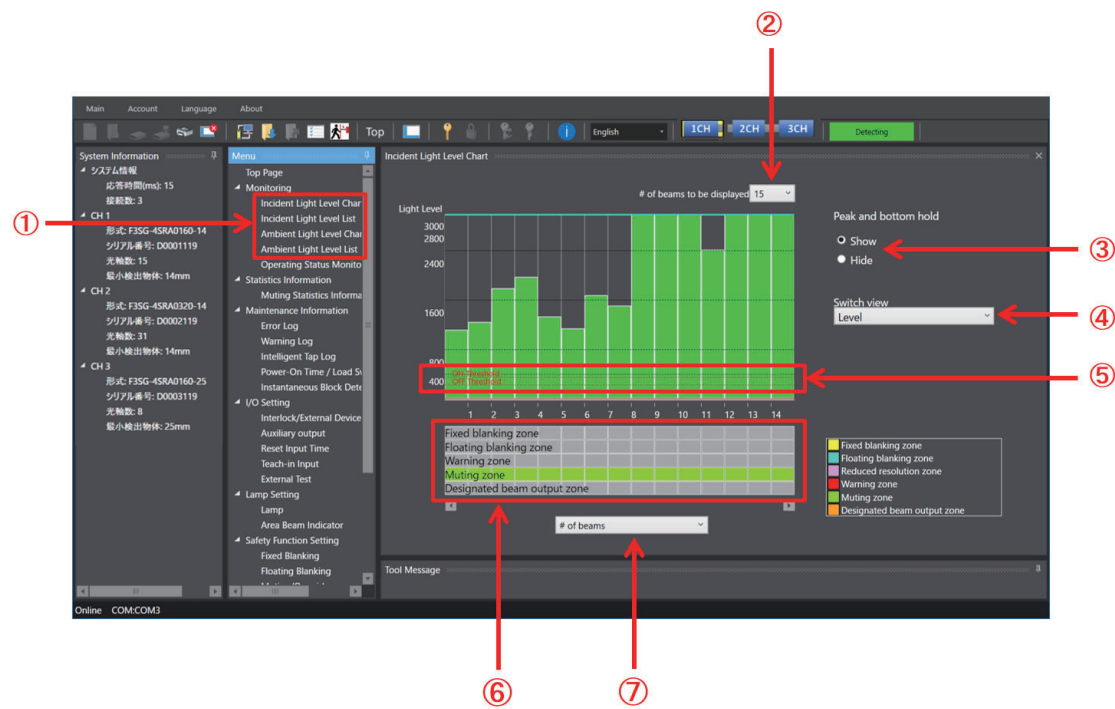

No.	Function	Description
1	Select light level monitoring function	Select incident light level or ambient light level to be monitored and chart or list view.
2	No. of beams to be displayed	Select the number of F3SG-SR/PG beams to be displayed.
3	Show/hide held peak and bottom hold	Shows the maximum and minimum values of a selected light level by light blue and pink lines, respectively when [Show] is selected.
4	Select unit of vertical axis *1*2	Switch the unit of the vertical axis on the chart between Percent and Level. When [Percent] is selected, the light level is shown in percentage based on the ON threshold value as 100%. When [Level] is selected, the light level is converted to voltage.

No.	Function	Description
5	ON/OFF threshold values *1	Shows the ON and OFF threshold values of the F3SG-SR/PG. This information is only shown when the [Level] view is selected for the unit of vertical axis.
6	Information assigned	Shows a function assigned to the beams. The following functions can be assigned for each sensor model. <ul style="list-style-type: none"> ■Functions which can be assigned for F3SG-SR -Fixed blanking zone -Floating blanking zone or Reduced resolution zone -Warning zone ■Functions which can be assigned for all sensor models -Muting zone -Designated beam output zone
7	Select unit of horizontal axis *1	Switch the unit of the horizontal axis on the chart between the number of beams and sensor length.

*1. Not displayed in the receiving light intensity list view.

*2. The horizontal axis indicates a level in the receiving light intensity list view.



CHECK!

Reduced resolution zone is displayed in the Information assigned section only when the reduced resolution is enabled.

4-4-1-2. Operating Status Monitoring

This function can be used only when the F3SG-SR/PG is connected to the Intelligent Tap and a PC. On the Top page, click the icon below.

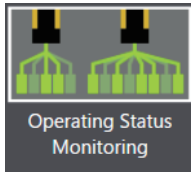

The F3SG-SR/PG enters detecting state, and the safety outputs are turned ON/OFF according to the beam state and settings.

CHECK!

The screen below is displayed.

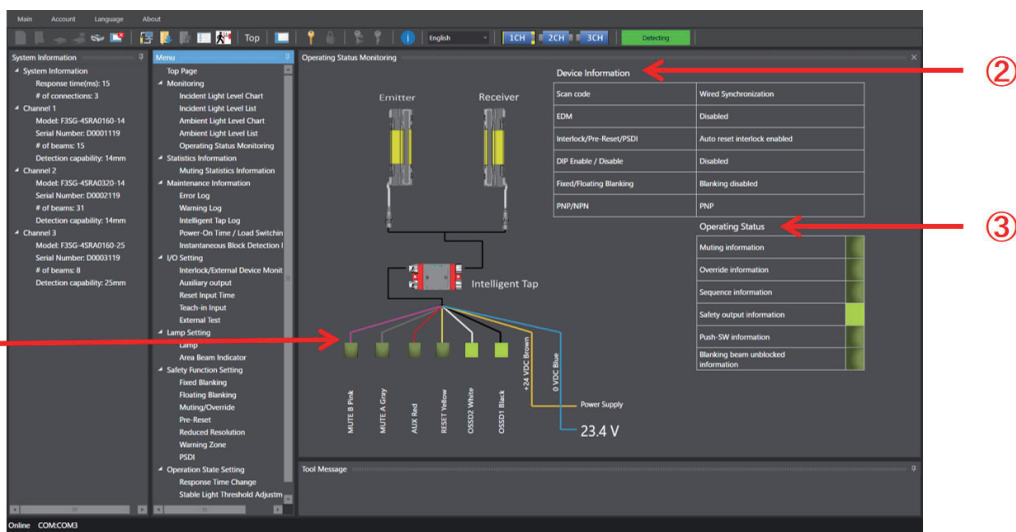

No.	Function	Description
1	External wiring status	Shows ON or OFF state of signal lines.
2	Sensor Information	When DIP Switch Enabled is selected, it shows a state of DIP Switch settings. When Configuration Tool Enabled is selected, it shows setting parameters saved in the F3SG-SR/PG.
3	Operating Status Monitoring	Shows the ON/OFF state of inputs and outputs of the F3SG-SR/PG. Shows Muting information, Override information, Sequence information, Safety output information, Push-SW information, and Blanking beam unblocked information.

■ Readout Information

The user can view the following information related to a receiver or emitter.

If more than one sensor is cascaded in series, information on all the cascaded sensors is viewed together.

Information		Description
External wiring	Power Supply	The power supply voltage in the power-on status is displayed.
	OSSD 1 (Black)	Linked with safety output 1
	OSSD 2 (White)	Linked with safety output 2
	RESET (Yellow)	Linked with Reset/EDM/Override input
	AUX (Red)	Linked with auxiliary output
	MUTE A (Gray)	Linked with MUTE A/Pre-Reset input/PSDI input
	MUTE B (Pink)	Linked with MUTE B input
Sensor	Scan code	Displays Scan Code configured
	EDM	Displays EDM configuration
	Interlock/Pre-Reset/PSDI	Displays Interlock/Pre-Reset/PSDI mode configured
	DIP Switch Enabled/Disabled	Displays whether the settings of the DIP Switch of the Intelligent Tap is enabled or disabled.
	Fixed/Floating Blanking	Displays Fixed/Floating Blanking configured
	PNP/NPN	Displays output mode (PNP/NPN) configured
Operating Status	Muting information	Linked with muting status
	Override information	Linked with override status
	Sequence error information	Linked with muting sequence error status or interlock sequence error status
	Safety output information	Linked with safety output
	Push-SW information	Linked with the input signal of Push Switch
	Blanking beam unblocked information	Linked with the state where the blanking beam is unblocked

4-4-2. Muting Statistics Information

This function can be used only when the F3SG-SR/PG is connected to the Intelligent Tap and a PC. This function logs and visualizes conditions of F3SG-SR/PG muting operations to help the user adjust settings of muting input time difference. Also, its statistic calculation allows for optimal settings with reduced test runs.

On the Top page, click the icon below.

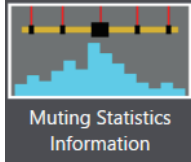

The screen below is displayed.

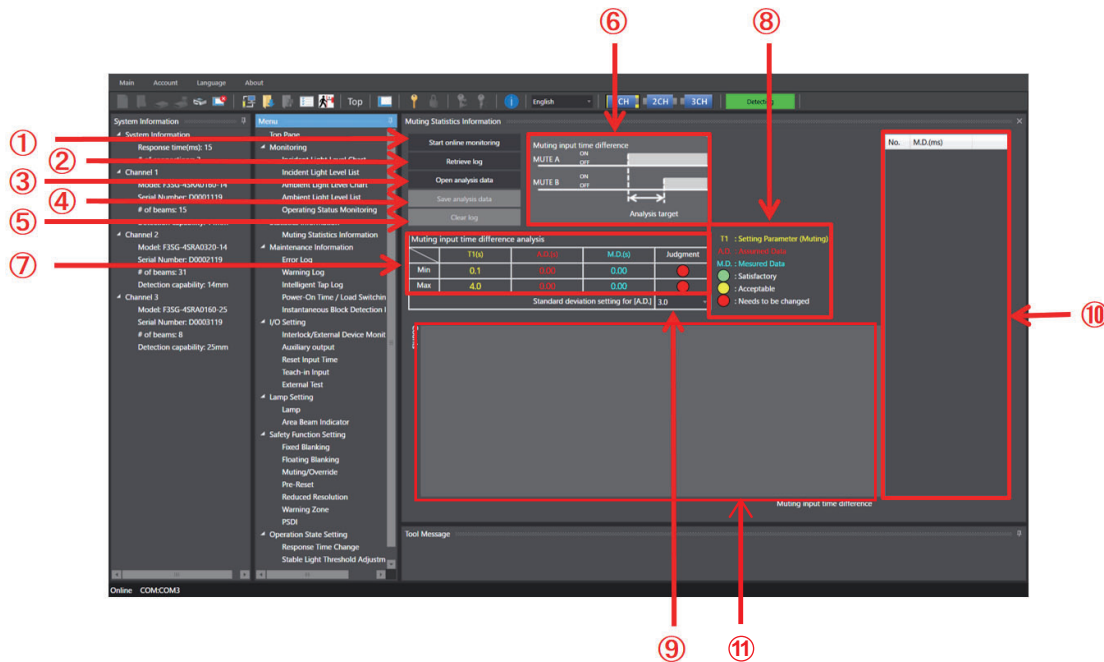

No.	Function	Description
1	Start (stop) online monitoring	Retrieves muting input time difference information from the F3SG-SR/PG in real time and displays it in the analysis data area (No. 10).
2	Retrieve log	Obtains the muting input time difference information saved in F3SG-SR/PG and displays it as Analysis Data (No. 10) and displays the graph as Graph (No. 11). Pressing this button switches the safety outputs to the OFF state and the operating state to [Setting state].
3	Open analysis data	Opens a .csv file saved by the operation (No. 4).
4	Save analysis data	Saves data displayed in the analysis data area (No. 10) as a .csv file. The data saved also includes other muting input time difference information and sensor information.
5	Clear log	Clears muting time logs saved in the F3SG-SR/PG.
6	Timing chart	Displays a timing chart of time analyzed.
7	Muting input time difference analysis table	Displays minimum and maximum values of muting setting parameter, assumed data and measured data, and judgment results on these values.
8	Description on muting input time difference analysis table	Displays meanings of abbreviations and judgment results in the table. A.D.: Assumed Data (the value calculated from M.D. using the standard deviation setting. The value of zero or less is handled as zero.) M.D.: Measured Data (the measured value of the time difference from muting input A to muting input B)
9	Standard deviation setting	The range of variation of assumed data can be selected from 2.6σ , 3.0σ and 6.0σ .

No.	Function	Description
10	Analysis data	Displays measured data of muting input time difference (to be analyzed).
11	Chart	Displays a setting parameters and assumed data of the chart (No. 7) and analyzed data (No. 10) in graph form.

■ Data Description

For the time data obtained, refer to the timing charts below.

■ Standard/ Position Detection Muting

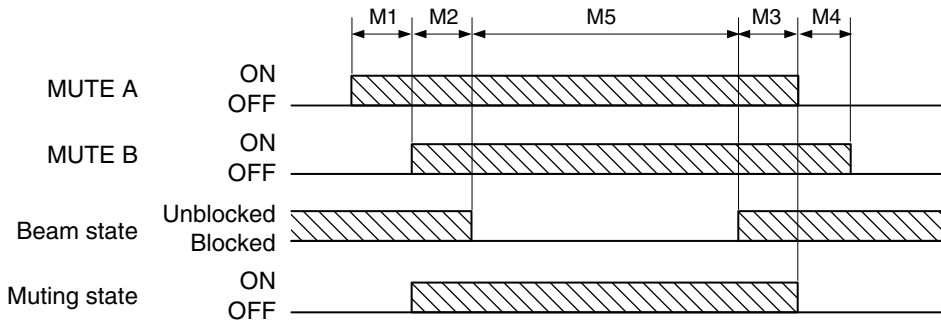

■ Exit Only Muting

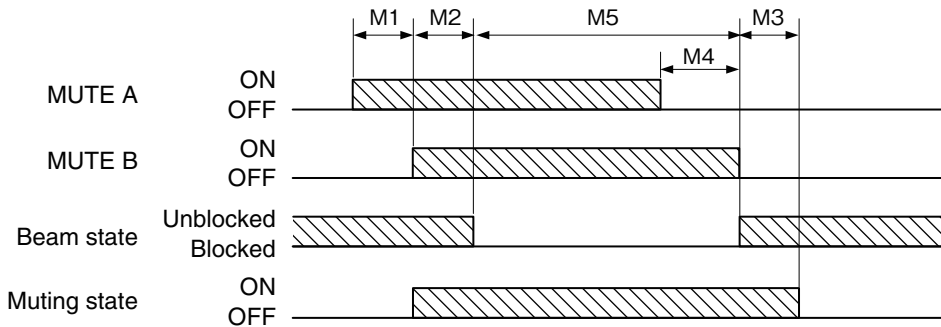

 M1 (input time difference) is the data to be analyzed for Muting Statistics Information.
 All M1 to M5 data and internal data will be saved in a .csv file when saving the analysis data.
 CHECK!

■ How to use muting statistics information

1. Carry out test runs including the muting in an actual installation environment.
 Performing the muting allows the F3SG-SR/PG to log muting information.

 If the F3SG-SR/PG used is secondhand, there may be logs of previous settings left in the F3SG-SR/PG.
 If you do not need such logs, delete them by the [Clear log] button before enabling the muting.
 CHECK! Once the muting statistics log is cleared, log information in the sensor cannot be restored. Save logs in advance, if necessary.
 Logs can be saved as a .csv file by selecting [Retrieve log] and [Save analysis data].

 It is necessary to perform the muting at least five times in order to obtain assumed data.
 CHECK!

2. Connect SD Manager 3 to the F3SG-SR/PG and display the muting statistics information screen above.
3. Clicking the [Retrieve log] button to obtain logs saved in the F3SG-SR/PG during the test runs in Step 1. Obtained data (table, chart and analysis data) is displayed in the screen.

4. Check the analysis data (10) to see if there is any unnecessary data.
It is possible to delete unnecessary data by selecting the data on the screen and pressing the [Delete] key. The table (7) and chart (11) will be updated each time analysis data is deleted.
If you have deleted analysis data accidentally, click the [Retrieve log] button again to recall it.
5. Select a desired standard deviation range (9) from the pull-down menu.
6. The flowchart below shows an example to optimize setting parameters of muting input time difference based on analysis data.

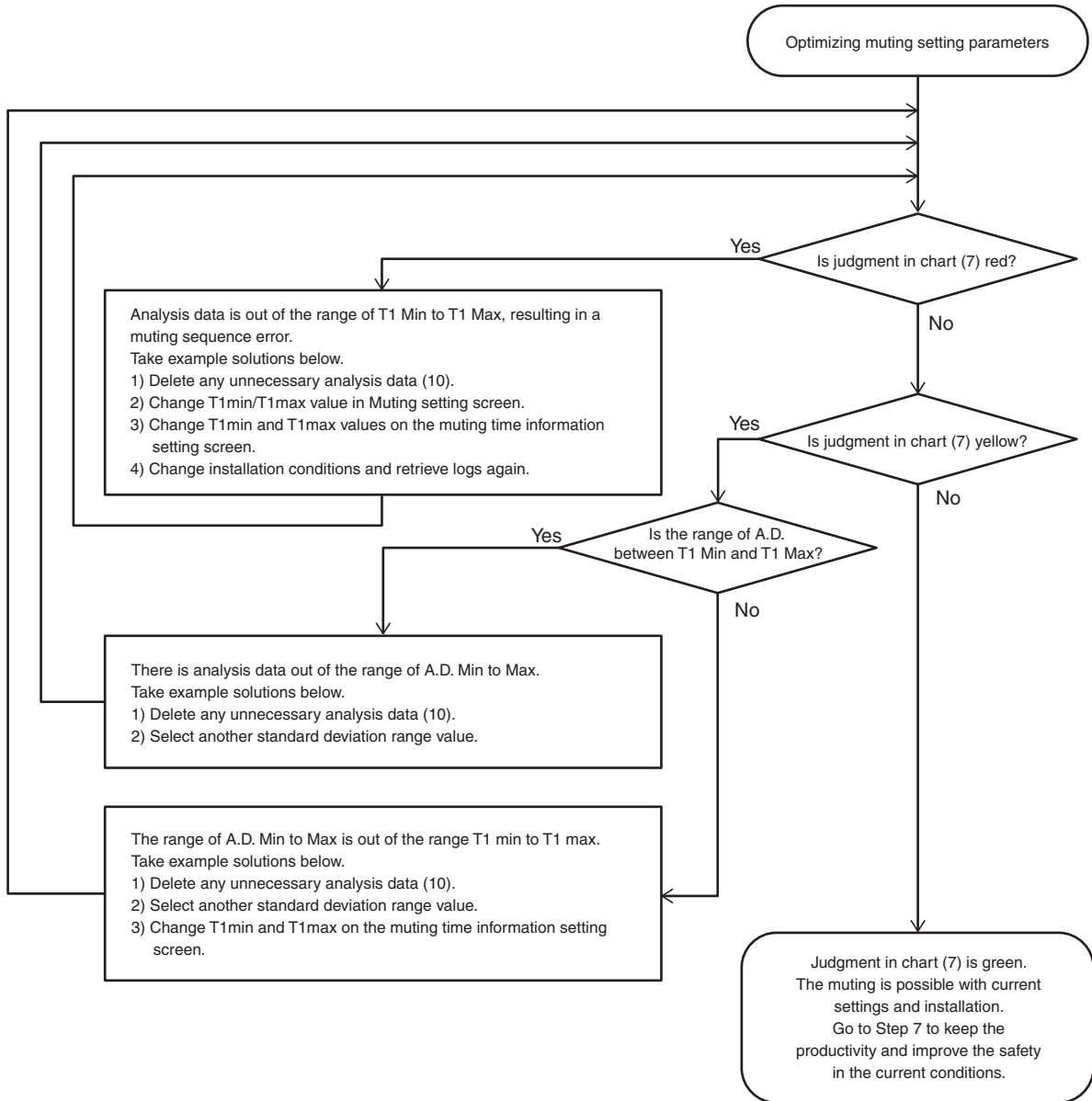

7. Adjusting the T1 Min and T1 Max closer to the A.D. Min and Max allows the user to keep the productivity and improve the safety.



The following operations in Step 7 are unnecessary if the T1 Min and T1 Max are fairly close to the A.D. Min and Max.



If you change T1 Min and T1 Max, make sure that these values satisfies "T1 Min < A.D. Min < A.D. Max < T1 Max".

When the optimization result below is obtained as a result of the flowchart above, there is a big difference between T1 Max and A.D. Max, and between T1 Min and A.D. Min. shown in the chart below.

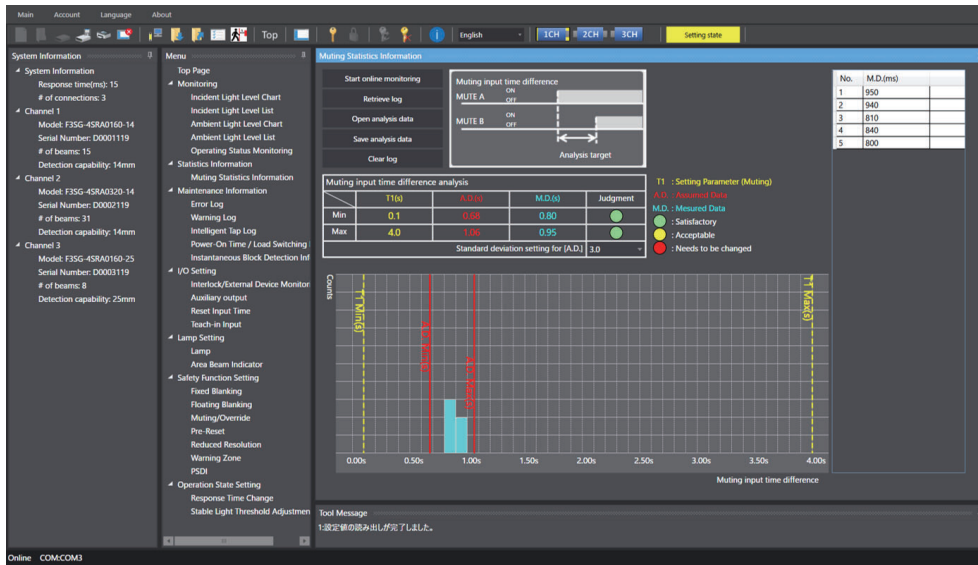

Now, change the T1 Min and T1 Max settings to 0.5 s and 1.0-1.2 s on the muting time information setting screen.

8. When setup is completed, execute writing into F3SG-SR/PG.

The deviation of T1 Min and Max from the A.D. Min and Max has been reduced, resulting in improved safety, as shown below.

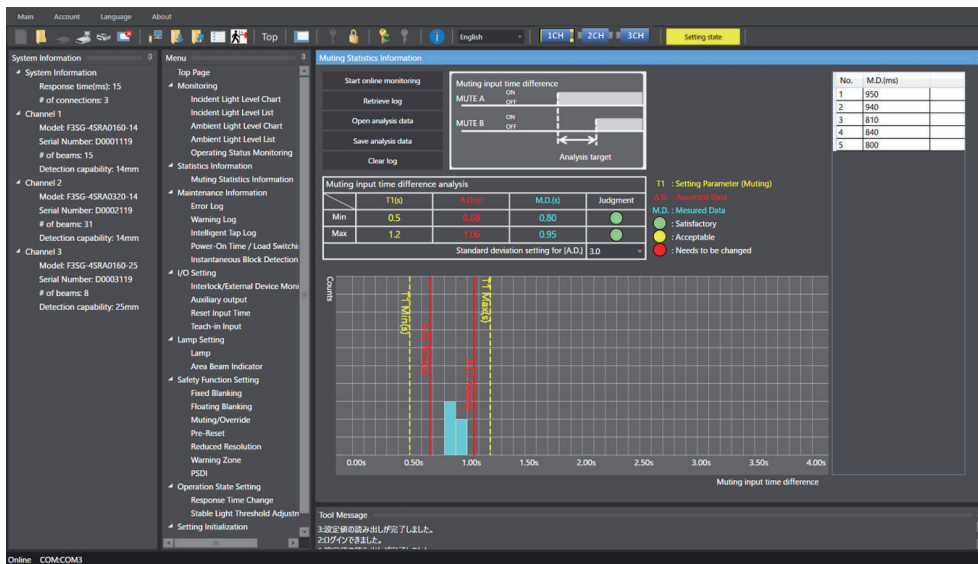

For more information on muting time information settings, refer to 4-3-4-3. Muting/Override.

4-4-3. Maintenance Information

Log in with the operator or administrator level to perform the monitoring functions described in this section.

4-4-3-1. Error Log Information

This function can be used only when the F3SG-SR/PG is connected to the Intelligent Tap and a PC. On the Top page, click the icon below.

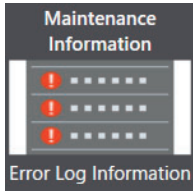

Alternatively, select [Error Log] from the [Maintenance Information] list in the [Menu] window.

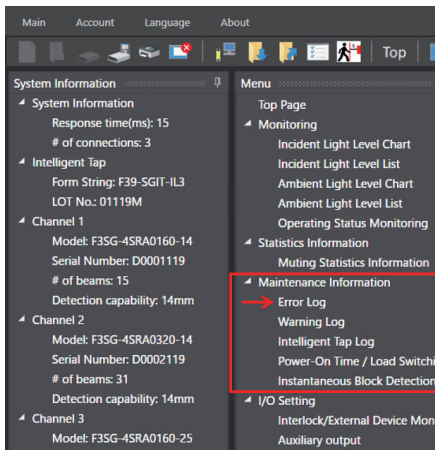

The screen below is displayed. Click an error item you want to view and the cause and measures of the error is displayed.

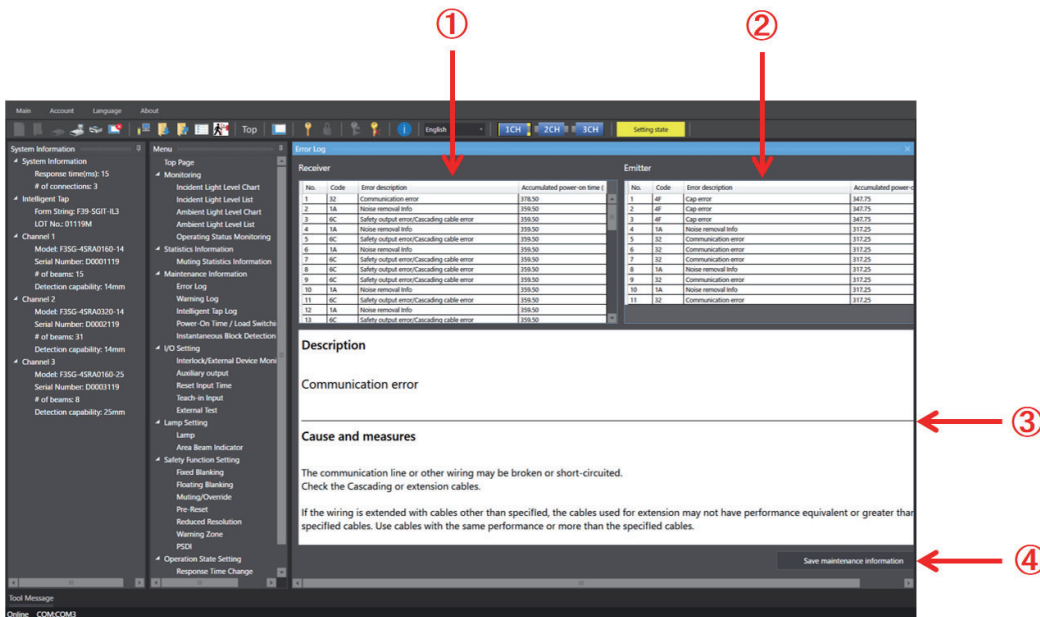

No.	Function	Description
1	Error Log Information (Receiver)	Shows error logs including error codes, error descriptions and accumulated power-on time at the time when errors occurred, with the most recent errors first for the receiver.
2	Error Log (Emitter) *	Shows error logs including error codes, error descriptions and accumulated power-on time at the time when errors occurred, with the most recent errors first for the emitter.
3	Show error descriptions	Click an error to show details, cause and measures of the event.
4	Save maintenance information	Saves error and warning logs, Intelligent Tap log, power-on time, accumulated power-on time, load switching frequency and accumulated load switching frequency as a .csv file.

* The error log information of the emitter is displayed only when the sensor is connected in the Wired Synchronization.



- Refer to 8-1-2. LOCKOUT State for more information on the error codes and descriptions.
- Refer to 2-27-4. Power-ON Time for more information on the accumulated power-on time.



CHECK!

- Error logs are only displayed for a sensor segment selected in the Target sensor section.
- Up to 50 past errors can be recorded. Up to last five logs are displayed without logging in.
- When configuring F3SG-SR in a cascade connection, select a desired sensor segment from the [Target sensor] button  in the top right corner of the screen.



CHECK!

For F3SG-PGA-C, the error log information of the emitter/receiver is displayed as classified into the internal emitter function and receiver function.

4-4-3-2. Warning Log

This function can be used only when the F3SG-SR/PG is connected to the Intelligent Tap and a PC. Select [Warning Log] from the [Maintenance Information] list in the [Menu] window.

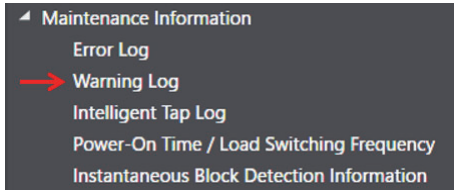

The screen below is displayed. Click a warning item you want to view and the cause and measures of the warning item is displayed.

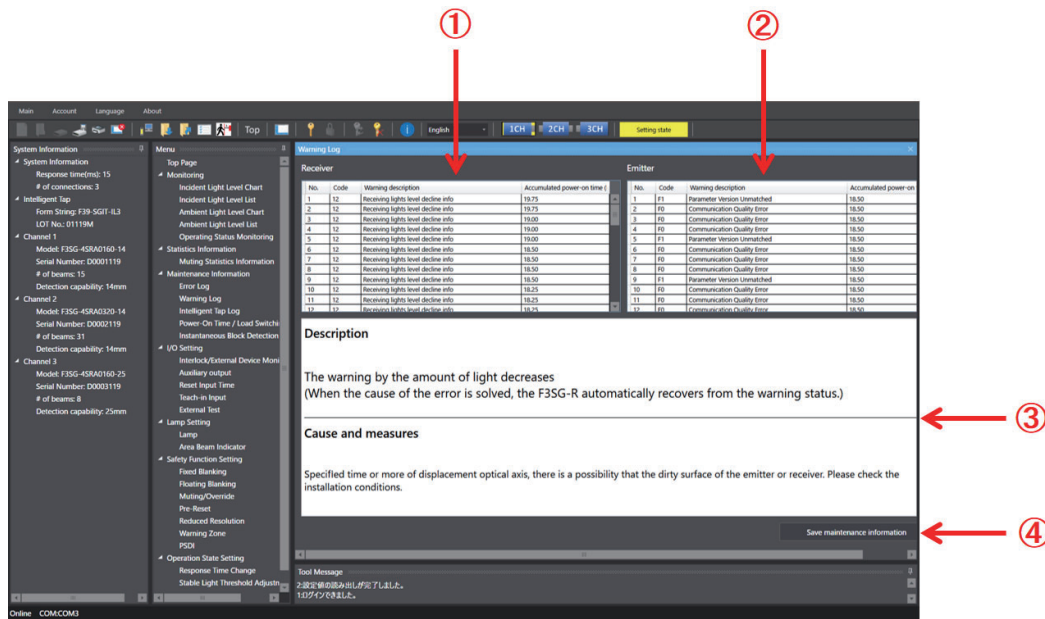

No.	Function	Description
1	Warning Log Information (Receiver)	Shows warning logs including warning codes, warning descriptions and accumulated power-on time at the time when warnings occurred, with the most recent warnings first for the receiver.
2	Warning Log Information (Emitter) *	Shows warning logs including warning codes, warning descriptions and accumulated power-on time at the time when warnings occurred, with the most recent warnings first for the emitter.
3	Show error descriptions	Click an error or warning log to show details, cause and measures of the event.
4	Save maintenance information	Saves error and warning logs, Intelligent Tap log, power-on time, accumulated power-on time, load switching frequency and accumulated load switching frequency as a .csv file.

* The warning log information of the emitter is displayed only when the sensor is connected in the Wired Synchronization.

- Refer to 8-1-3. *Warning* for more information on the warning codes and descriptions.
- Refer to 2-27-4. *Power-ON Time* for more information on the accumulated power-on time.
- Warning logs are only displayed for a sensor segment selected in the Target sensor section.
- Up to 50 past warnings can be recorded. Up to last five logs are displayed without logging in.
- When configuring F3SG-SR in a cascade connection, select a desired sensor segment from the [Target sensor] button  in the top right corner of the screen.
- For F3SG-PGA-C, the warning log information of the emitter/receiver is displayed as classified into the internal emitter function and receiver function.

4-4-3-3. Intelligent Tap Log

This function can be used only when the Intelligent Tap is connected to a PC. This function can be used regardless of whether or not the F3SG-SR/PG is connected with the Intelligent Tap. Select [Intelligent Tap Log] from the [Maintenance Information] list in the [Menu] window.

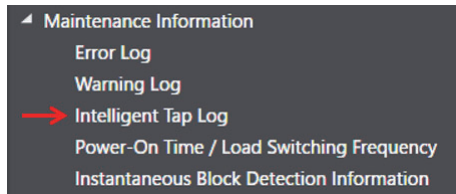

The screen below is displayed. Click an error item you want to view and the cause and measures of the error is displayed.

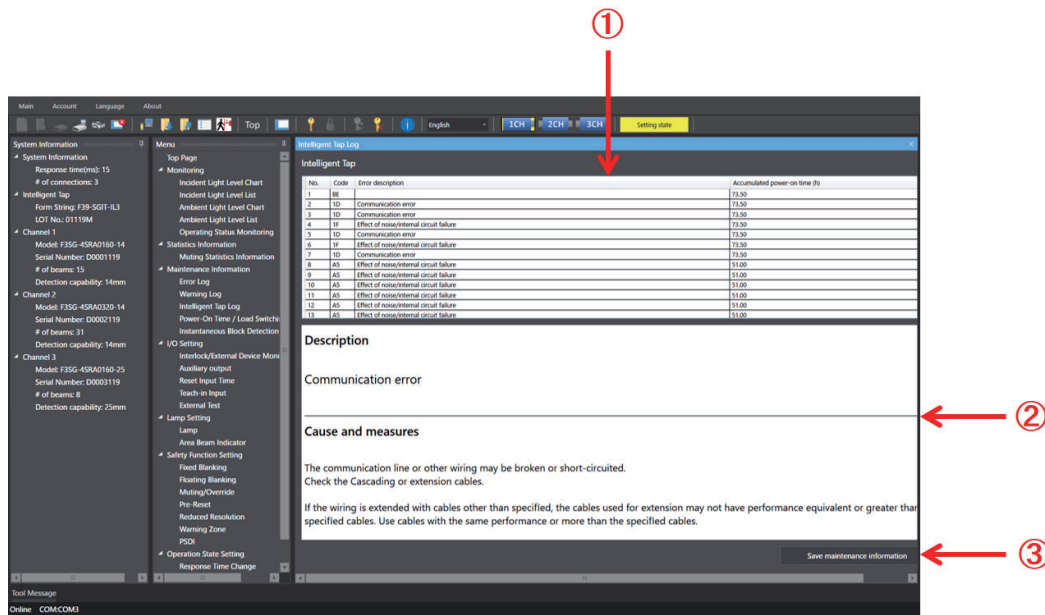

No.	Function	Description
1	Intelligent tap log	Error code, error details, and the accumulated power-on time when the error occurred are displayed in order from the newest log.
2	Error details indication	By clicking each log, the details, cause, and countermeasures about the log are displayed.
3	Maintenance information saving	Saves error and warning logs, Intelligent Tap log, power-on time, accumulated power-on time, load switching frequency and accumulated load switching frequency as a .csv file.

- Refer to 8-1-4. *Troubleshooting for Intelligent Tap* for more information on the error codes and descriptions of the Intelligent Tap.
- Refer to 2-27-7. *Intelligent Tap Log* for more information on the accumulated power-on time.

Logs of past 50 errors are saved in the Intelligent Tap log.



4-4-3-4. Power-On Time/Load Switching Frequency

This function can be used only when the F3SG-SR/PG is connected to the Intelligent Tap and a PC. Select [Power-On Time/Load Switching Frequency] from the [Maintenance Information] list in the [Menu] window.

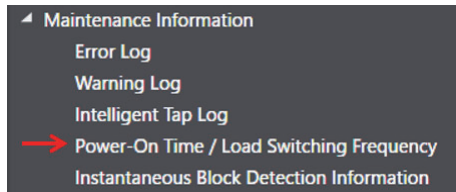

Then, the screen below is displayed.

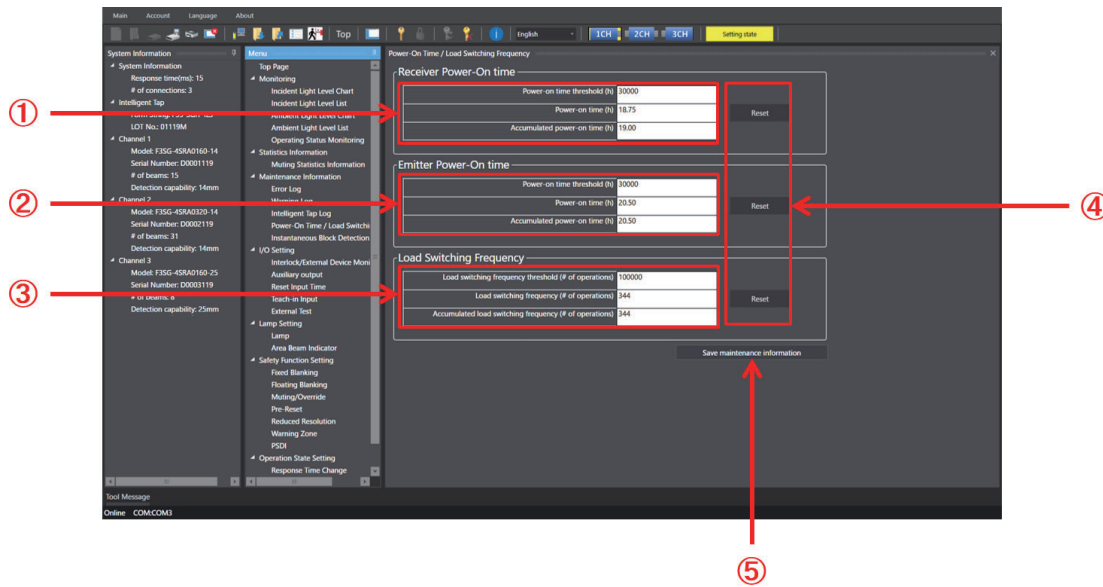

No.	Function name	Description	Initial value	Configurable item
1	Receiver power-on time	Shows power-on time threshold, power-on time and accumulated power-on time for the receiver. Only power-on time threshold is configurable.	• Power-on time threshold: 30,000 h	• Power-on time threshold: 30,000 to 1,000,000 h (in 1-h increments)/Disable
2	Emitter power-on time *	Shows power-on time threshold, power-on time and accumulated power-on time for the emitter. Only power-on time threshold is configurable.	• Power-on time threshold: 30,000 h	• Power-on time threshold: 30,000 to 1,000,000 h (in 1-h increments)/Disable
3	Load switching frequency	Shows load switching frequency threshold, load switching frequency and accumulated load switching frequency. Only load switching frequency threshold is configurable.	• Load switching frequency threshold: 100,000 h	100,000 to 4,000,000 times (in 1-time increments/Disable)
4	Reset	Resets power-on time and load switching frequency to zero. Resetting is only possible when you are logged in with the administrator level.	-	-
5	Save maintenance information	Saves error and warning logs, Intelligent Tap log, power-on time, accumulated power-on time, load switching frequency and accumulated load switching frequency as a .csv file.	-	-

* The emitter power-on time is displayed only when the sensor is connected in the Wired Synchronization.



- Refer to 2-27-4. *Power-ON Time* for more information on the accumulated power-on time.
- Refer to 2-27-5. *Load Switching Frequency* for more information on the load switching frequency.



CHECK!

- Writing the configurations of power-on time threshold and load switching frequency threshold to the F3SG-SR/PG is also possible with the operator level.
- The power-on time information is recorded in the F3SG-SR/PG main unit every 15 minutes.
- When configuring F3SG-SR in a cascade connection, select a desired sensor segment from the [Target sensor] button  in the top right corner of the screen.
- When changing the settings is complete, confirm the settings and write the configuration to the F3SG-SR/PG. To enable the written configuration, refer to 4-2-7-3. *Writing Configuration into Intelligent Tap*.

4-4-3-5. Instantaneous Block Detection Information

This function can be used only when the F3SG-SR/PG is connected to the Intelligent Tap and a PC. On the top page, click the icon below.



Alternatively, select [Instantaneous Block Detection Information] from the [Maintenance Information] list in the [Menu] window.

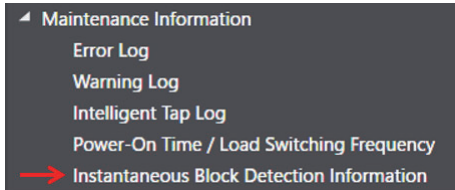

The screen below is displayed.

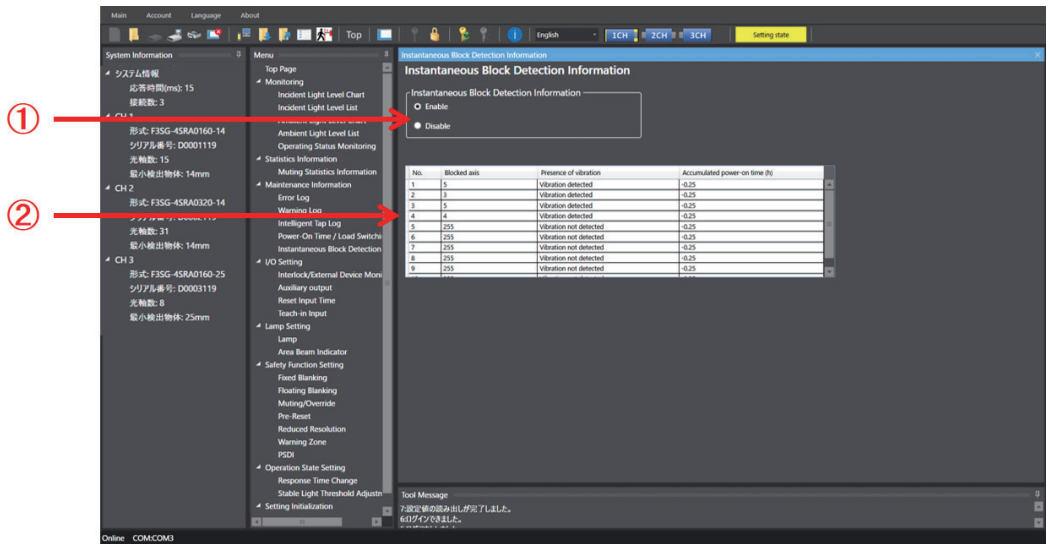

No.	Function name	Description	Initial value	Configurable item
1	Instantaneous Block Detection Information	Select Enable or Disable for the instantaneous block detection information display function.	Enable	Enable/Disable
2	Instantaneous Block Detection Log Information	Displays blocked beams, presence of vibration, and accumulated power-on time at the time when instantaneous block occurred in order from the newest instantaneous block detection log.	-	-

Refer to 2-29. *Instantaneous Block Detection* for more information on the Instantaneous Block Detection function.

When configuring F3SG-SR in a cascade connection, select a desired sensor segment from the [Target sensor] button in the top right corner of the screen.



CHECK!

4-5. Basic Operation of SD Manager 3 Mobile APP

4-5-1. How to Install/Uninstall SD Manager 3 Mobile APP

4-5-1-1. Installing SD Manager 3 Mobile APP

Download SD Manager 3 Mobile APP from the following website and install it.

URL: https://www.fa.omron.co.jp/f3sg-srpg_tool/

4-5-1-2. Uninstalling SD Manager 3 Mobile APP

Delete SD Manager 3 Mobile APP according to the procedure of your smartphone.

4-5-2. How to Update SD Manager 3 Mobile APP

Download the new SD Manager 3 Mobile APP from the following website and install it.

URL: https://www.fa.omron.co.jp/f3sg-srpg_tool/

4-5-3. Pairing (Connection Verification)

Pairing is the process required for the Bluetooth® Communication Unit and a device with Bluetooth® wiring technology to recognize and connect with each other.

Indications and operations of the pairing process are different depending on a Bluetooth® device used. Always refer to instruction manuals of such a device when pairing the devices.



When the Bluetooth® Communication Unit and a Bluetooth® device are not paired, it is not possible to connect to the Bluetooth® Communication Unit. These must be paired in advance.

CHECK!



Once the Bluetooth® Communication Unit and a Bluetooth® device are paired, it is not necessary to pair them again.

CHECK!

■ Compatible Products (Smartphones)

[Verification steps conducted by OMRON]

- (1) Pair a smartphone with the Bluetooth® Communication Unit and confirm on its setting window that the pairing is complete.
- (2) After confirming the step (1), verify by the SD Manager 3 Mobile APP that the communication with the F3SG-SR/PG is established.



When connecting F3SG-SR/PG, if a device other than F3SG-SR/PG is using the SPP (Serial Port Profile) communication, the device is not able to connect to F3SG-SR/PG. If it is not able to connect to F3SG-SR/PG after pairing is done, release all pairing of the smartphone once and perform pairing again.

CHECK!

[Verification results]

Smartphones verified by OMRON are listed in the table below.

Note: The verification conducted by OMRON does not guarantee all performance of the devices.

[List of compatible smartphones (as of May 1, 2019)]

Device	Maker	Model (Model name)
Smartphone	HUAWEI	P20 lite
	Samsung Electronics	Galaxy S8 Dual-SIM SM-G950FD
	SHARP	AQUOS sense lite SH-M05
	Sony Mobile Communications	Xperia X Dual F5122
	XIAOMI	Mi A2 Lite

 For supported smartphone OSs, refer to 4-1-2-2. *Smartphone Environment*.

4-5-4. Getting Started, Main Screen, Version Confirmation, and Shutting Down

4-5-4-1. Getting Started

To start SD Manager 3 Mobile APP, tap the SD Manager 3 Mobile APP icon  added to the home screen when the APP is installed.

The SD Manager 3 Mobile APP starts and the screen below is displayed.

■ If the device is connected

If the device is connected, a pop-up message indicating that connection is established is displayed. In addition, a dialog message indicating that sensor information is read completely is displayed.

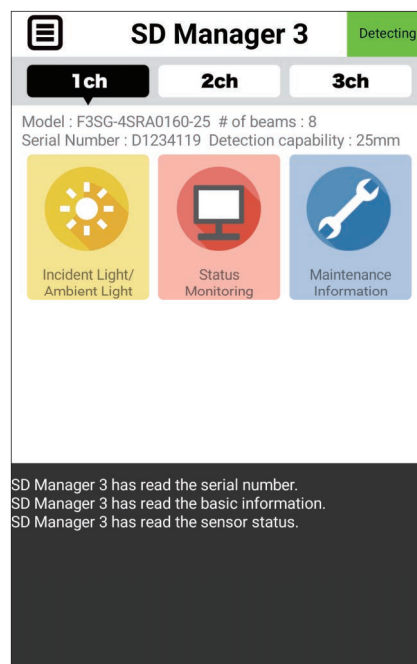

■ If the device is not connected

If the device is not connected, no dialog message is displayed.

In addition, a pop-up message saying “Not connected with the sensor” is displayed when tapping each icon.

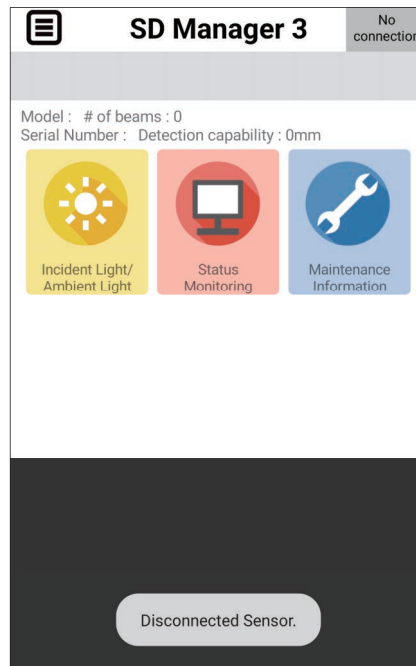

CHECK!

If pairing is has not been done yet, refer to 4-5-3. *Pairing (Connection Verification)*.



CHECK!

If unable to connect with the sensor although pairing is already completed, confirm again that the Bluetooth® communication function of the smartphone is ON.

4-5-4-2. Main Screen

This section describes each icon of the main screen.



No.	Function name	Description
1	Menu button	Displays the menu screen. From this menu screen, you can confirm the app version or shut down the app. For details, refer to 4-5-4-3. <i>Version Information</i> and 4-5-4-4. <i>Shutting Down</i> .
2	Sensor operating state display	Shows the following statuses of the F3SG-SR/PG. <div style="display: flex; flex-direction: column; gap: 10px;"> <div style="display: flex; align-items: center;"> <div style="background-color: #90EE90; padding: 5px; margin-right: 10px;">Detecting</div> <p>Operating: The F3SG-SR/PG keeps normal operation.</p> </div> <div style="display: flex; align-items: center;"> <div style="background-color: #FFFF00; padding: 5px; margin-right: 10px;">Setting State</div> <p>Setting state: It is possible to read configuration from the F3SG-SR/PG. The safety outputs of the F3SG-SR/PG are in the OFF state.</p> </div> <div style="display: flex; align-items: center;"> <div style="background-color: #FF0000; color: white; padding: 5px; margin-right: 10px;">Lockout State</div> <p>Lockout state: The F3SG-SR/PG is in the LOCKOUT State.</p> </div> <div style="display: flex; align-items: center;"> <div style="background-color: #A9A9A9; padding: 5px; margin-right: 10px;">No connection</div> <p>No connection: The F3SG-SR/PG and SD Manager 3 Mobile APP are disconnected or not properly connected.</p> </div> </div>
3	Channel switching	Select the channel monitored. The display changes according to the cascade connection of the F3SG-SR/PG.
4	Sensor basic information display	Shows information on the F3SG-SR/PG connected.
5	Function icon display *1	Displays the function capable of displaying the monitored information on the screen.
6	Log display	Displays messages according to the user operations and connection states.

4-5-4-3. Version Information

The version of SD Manager 3 can be confirmed by the following method.

1. Select [About] from the [Menu] button .

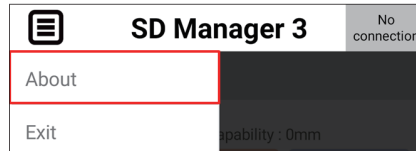

2. The pop-up screen below is displayed, and the version is displayed in the red frame.

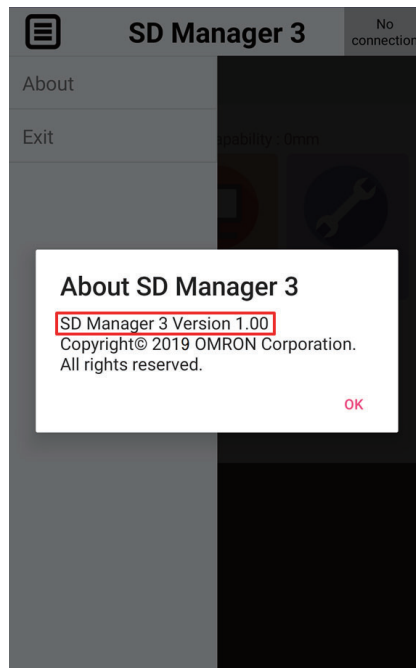

4-5-4-4. Shutting Down

To shut down SD Manager 3, kill the task according to the specification of the smartphone, or execute the method below.

1. Select [Exit] from the [Menu] button .

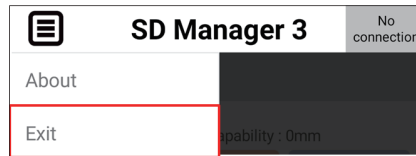

2. The pop-up screen below is displayed, so select [Yes] to exit SD Manager 3.

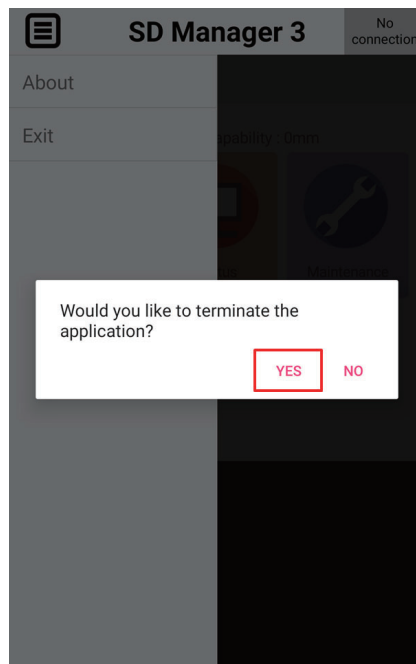

4-5-5. Monitoring with SD Manager 3

4-5-5-1. Incident/Ambient Light Level Monitoring

Tap the following icons on the main screen.

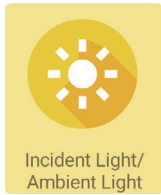

The screen below is displayed.



No.	Function name	Description
1	Light level monitoring operation	Starts or stops monitoring of the selected function.
2	Incident light/ambient light switching	Select either incident light or ambient light as the monitoring target.
3	Peak and bottom holding operation	When setting the display, the maximum and minimum values of incident light are displayed with a water-color and pink lines, respectively.
4	Zone display	Displays the function assigned to the beam. Each display means the following function. <ul style="list-style-type: none"> • DS: Designated beam output zone • MT: Muting zone • WR: Warning zone • FL: Floating blanking zone or RR: Reduced resolution zone • FX: Fixed blanking zone
5	Beam display *1	Displays the beams of the F3SG-SR/PG being monitored.
6	Light level display	Displays the light level and ON/OFF threshold of the selected function.
7	Function switching	The icon of the function which is being monitored is highlighted. Tapping the icon of the other function switches to the display of the corresponding function.

*1. In case of F3SG-PGA-C, the number of displayed beams is a half of that in the model specifications.

For more information on the number of beams for each model, refer to 1-6-1-2. F3SG-PG Series.



By the zone display, the reduced resolution zone is displayed only when the applicable function is enabled.

4-5-5-2. Status Monitoring Information

■ Sensor Status Information

Tap the following icons on the main screen.

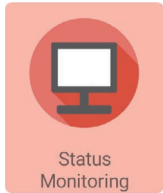

The screen below is displayed.

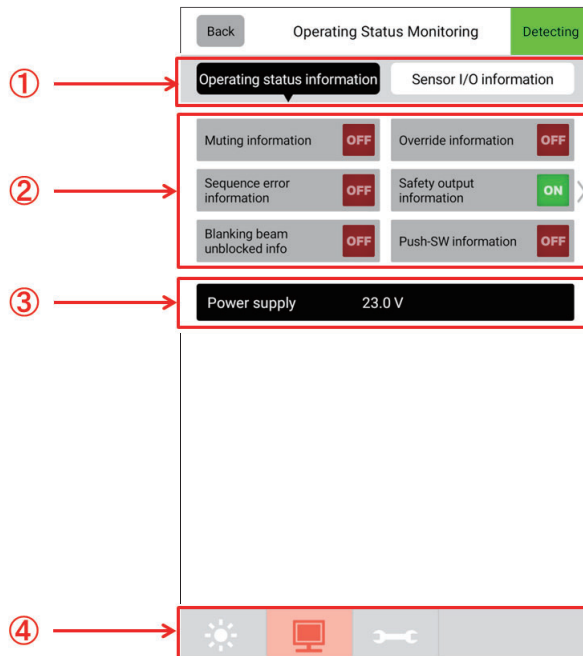

No.	Function name	Description
1	Status switching	As the monitoring target, select either sensor status information or sensor I/O information.
2	Sensor status display	Displays the status of the sensor being monitored.
3	Power supply voltage display	Displays the power supply voltage of the sensor being monitored.
4	Function switching	The icon of the function which is being monitored is highlighted. Tapping the icon of the other function switches to the display of the corresponding function.

■ Sensor I/O Information

Sensor I/O information can be displayed by the following method.

1. Tap the following icons on the main screen.

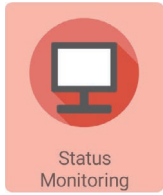

2. On the status monitoring screen, tap [Sensor I/O information] from the [Status Switching] button.

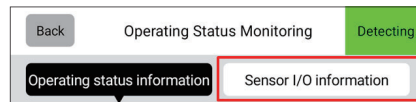

3. The screen below is displayed.

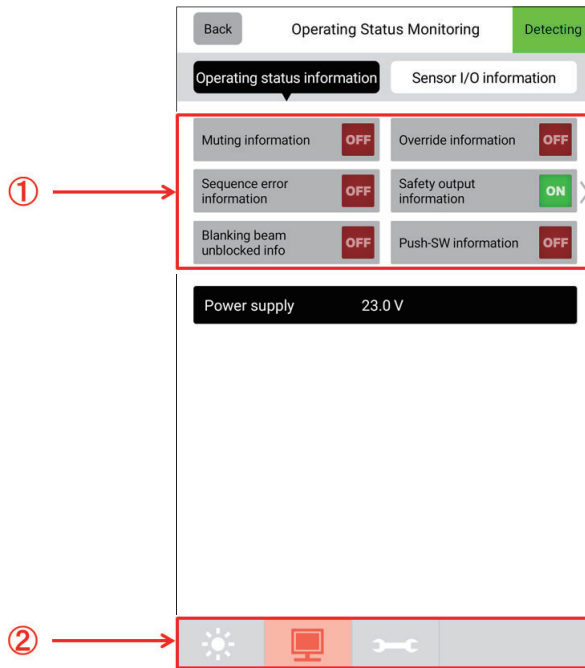

No.	Function name	Description
1	Sensor I/O information display	Displays the I/O information of the sensor being monitored.
2	Function switching	The icon of the function which is being monitored is highlighted. Tapping the icon of the other function switches to the display of the corresponding function.

4-5-5-3. Maintenance Information

■ Maintenance Information

Tap the following icons on the main screen.

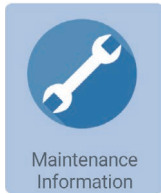

The screen below is displayed.

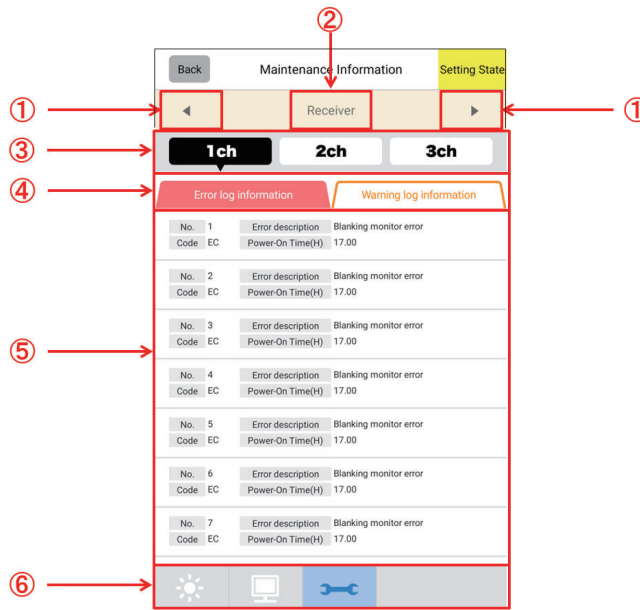

No.	Function name	Description
1	Device switching	Switches the device monitored.
2	Device display	Displays the device being monitored.
3	Channel switching	Select the channel monitored. The display changes according to the cascade connection of the F3SG-SR/PG.
4	Error/warning log switching	Select the type of the log monitored from error log or warning log.
5	Log list	Displays the codes, descriptions, and accumulated power-on time of the errors/warnings in order from the newest log.
6	Function switching	The icon of the function which is being monitored is highlighted. Tapping the icon of the other function switches to the display of the corresponding function.



- The error/warning log function displays the information on the channel selected as the setting target.
- The error/warning log function records logs for the past 50 errors/warnings.
- Selecting the Maintenance Information switches the F3SG-SR/PG to the SETTING state. Refer to 4-1-4. SETTING State of F3SG-SR/PG with SD Manager 3 Connected for more information on the SETTING state.
- Tapping an icon of another function returns the F3SG-SR/PG to the [Detecting] state.

■ Maintenance Information

By tapping each error/warning log on the maintenance information screen, the screen moves to the maintenance information details screen and the following screen is displayed.

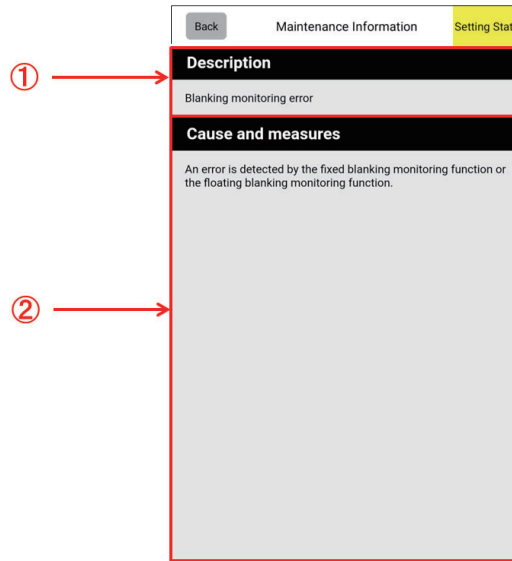

No.	Function name	Description
1	Error /warning description	Displays the details of each error/warning.
2	Cause and measures	Displays the cause and measures of the error/warning.

4-6. SD Manager 3 Application Example

4-6-1. Changing F3SG-SR/PG settings using SD Manager 3

You can connect the Intelligent Tap and PC with a USB cable and change the F3SG-SR/PG settings using SD Manager 3.

■ Work steps

1. If no Intelligent Tap is installed to the facility to operate and a new one is to be installed to change the settings, perform the steps in 3-10-2. *Saving Sensor Setting to Intelligent Tap Using Backup Function* first.
2. Use a Phillips screwdriver to remove the cover of the Intelligent Tap.

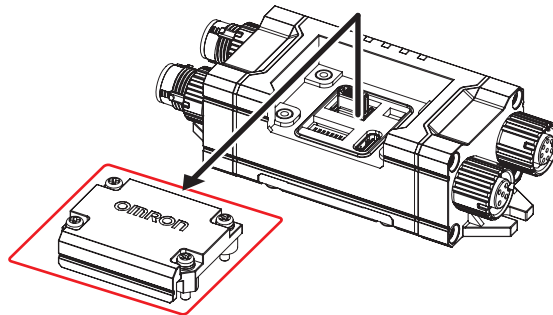

3. Set the DIP Switch position 1 ON and position 2 OFF.

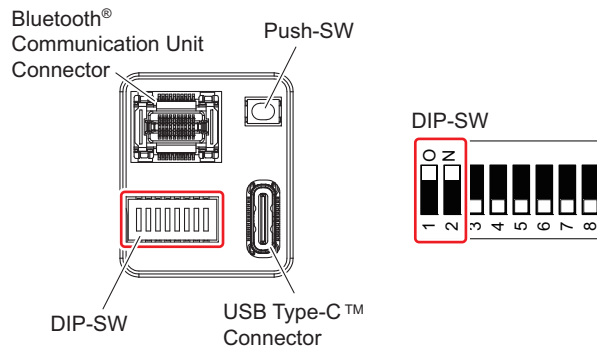

- Set the DIP Switch positions 3 to 8 OFF.

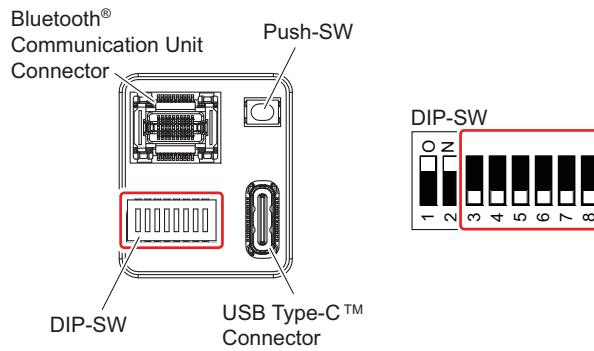

- Turn on power of the Intelligent Tap and F3SG-SR/PG.
- Check the indicators on the Intelligent Tap if it is running normally.

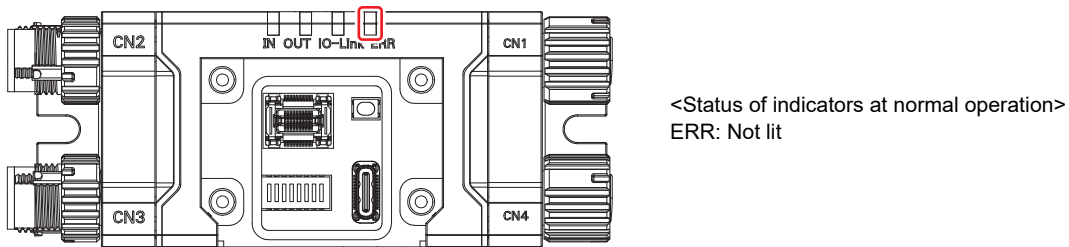

If the ERR indicator is ON, turn off power of the Intelligent Tap and F3SG-SR/PG, make sure that the wiring is proper, and go back to step 3 to perform the steps again.

- Connect a USB cable to the Intelligent Tap.

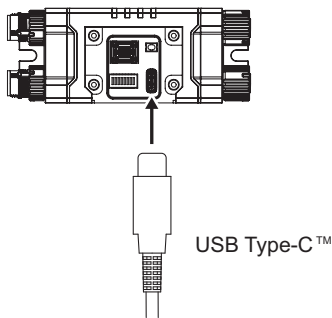

- Connect the USB cable to the PC and run SD Manager 3.
- Use SD Manager 3 to edit the settings.
For how to configure the settings, refer to 4-3. *Changing Settings with SD Manager 3.*
- After editing the settings, click [Write configuration] on the Tool menu of SD Manager 3. The settings are written to F3SG-SR/PG and Intelligent Tap.

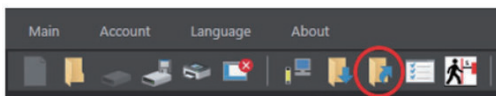

- If a write error message appears, go back to step 3 to perform the steps again.

12. If you need to save the settings, click [Save] or [Save As] on the Tool menu of SD Manager 3 to save the settings in any place in the PC.
13. Turn off power of the Intelligent Tap and F3SG-SR/PG, then turn on power of them.



The settings are not enabled unless the Intelligent Tap and F3SG-SR/PG are restarted.

14. Check that F3SG-SR/PG runs with the intended settings.
If it does not, go back to step 3 to perform the steps again.
Also, check the settings edited by SD Manager 3.
15. Detach the USB cable from the Intelligent Tap.
16. Use a Phillips screwdriver to attach the cover of the Intelligent Tap.
(Recommended tightening torque: 0.35N·m)

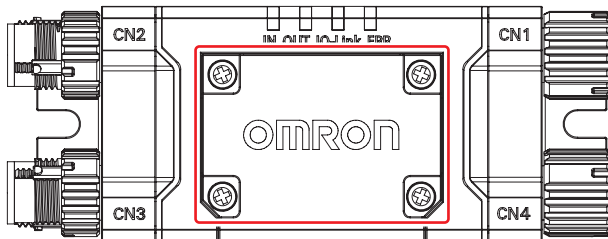

■ To finish the maintenance task and start normal operation of the facility, perform the followings.

1. If a cable is not attached to CN3, use the torque wrench XY2F-0004 to attach the accessory waterproof cover (for plug).
(Recommended tightening torque for waterproof cover plug: 0.39 to 0.49N·m)
2. If a cable is not attached to CN4, attach the accessory waterproof cover (for socket).

■ After configuring the settings, if you need to detach the Intelligent Tap from the facility, use the following steps.

1. Turn off power of the Intelligent Tap and F3SG-SR/PG.
2. Remove the Intelligent Tap and restore the wiring before configuring the settings.

4-6-2. Reading out F3SG-SR/PG settings using SD Manager 3

You can connect the Intelligent Tap and PC with a USB cable and change the F3SG-SR/PG settings using SD Manager 3 via the USB cable.

■ Work steps

1. If no Intelligent Tap is installed to the facility to operate and a new one is to be installed to change the settings, perform the steps in 3-10-2. *Saving Sensor Setting to Intelligent Tap Using Backup Function* first.
2. Use a Phillips screwdriver to remove the cover of the Intelligent Tap.

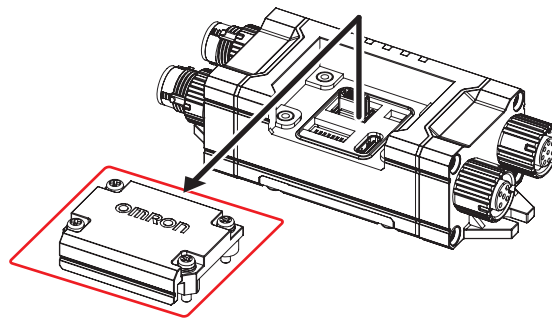

3. Set the DIP Switch position 1 ON and position 2 OFF. You do not need to change other positions.

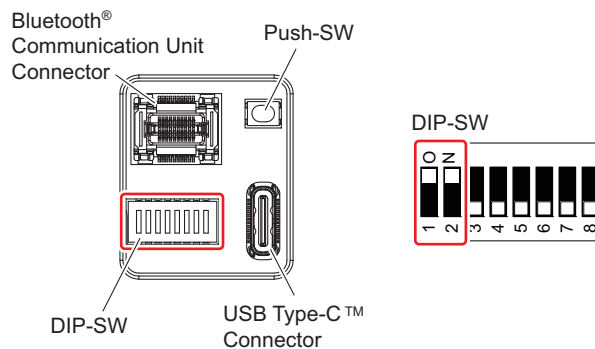

4. Turn on power of the Intelligent Tap and F3SG-SR/PG.
5. Check the indicators on the Intelligent Tap if it is running normally.

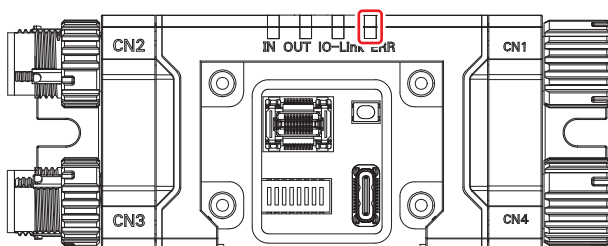

<Status of indicators at normal operation>
ERR: Not lit

If the ERR indicator is ON, turn off power of the Intelligent Tap and F3SG-SR/PG, make sure that the wiring is proper, and go back to step 3 to perform the steps again.

6. Connect a USB cable to the Intelligent Tap.

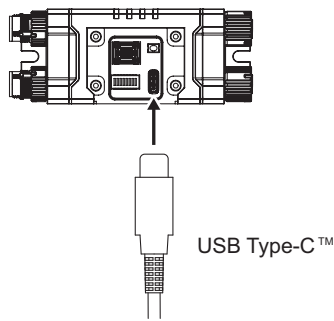

7. Connect the USB cable to the PC and run SD Manager 3.
8. Click [Read configuration] on the Tool menu of SD Manager 3. The setup data is loaded from the Intelligent Tap.

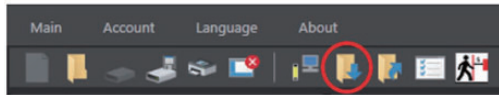

9. If you need to save the settings, click [Save] or [Save As] on the Tool menu of SD Manager 3 to save the settings in any place in the PC.
10. Detach the USB cable from the Intelligent Tap.
11. Use a Phillips screwdriver to attach the cover of the Intelligent Tap. (Recommended tightening torque: 0.35N·m)

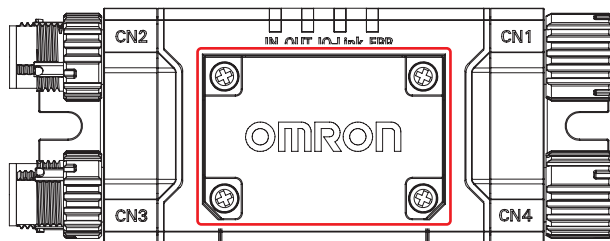

- To finish the maintenance task and start normal operation of the facility, perform the followings.
 1. If a cable is not attached to CN3, use the torque wrench XY2F-0004 to attach the accessory waterproof cover (for plug).
(Recommended tightening torque for waterproof cover plug: 0.39 to 0.49N·m)
 2. If a cable is not attached to CN4, attach the accessory waterproof cover (for socket).

- After configuring the settings, if you need to detach the Intelligent Tap from the facility, use the following steps.
 1. Turn off power of the Intelligent Tap and F3SG-SR/PG.
 2. Remove the Intelligent Tap and restore the wiring before configuring the settings.

4-6-3. Monitoring F3SG-SR/PG status using SD Manager 3

You can connect the Intelligent Tap and PC with a USB cable and monitor the F3SG-SR/PG status using SD Manager 3.

■ Work steps

1. If no Intelligent Tap is installed to the facility to operate and a new one is to be installed to change the settings, perform the steps in 3-10-2. *Saving Sensor Setting to Intelligent Tap Using Backup Function* first.
2. Use a Phillips screwdriver to remove the cover of the Intelligent Tap.

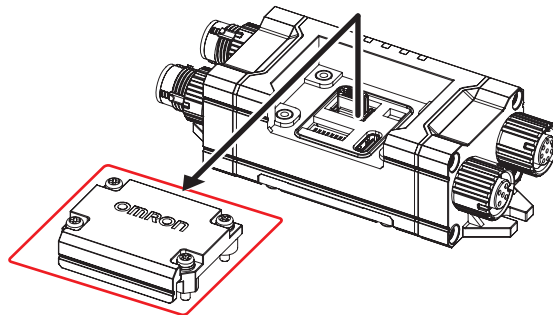

3. Set the DIP Switch position 1 ON.
You do not need to change other positions.

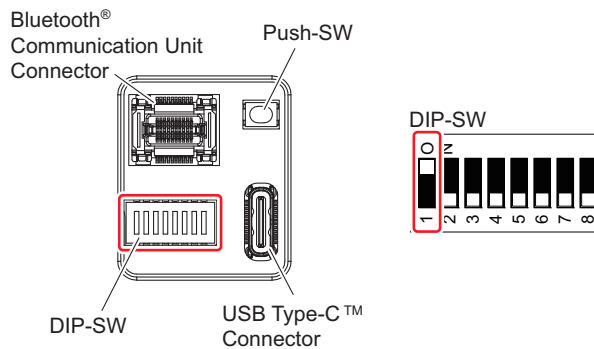

4. Turn on power of the Intelligent Tap and F3SG-SR/PG.
5. Check the indicators on the Intelligent Tap if it is running normally.

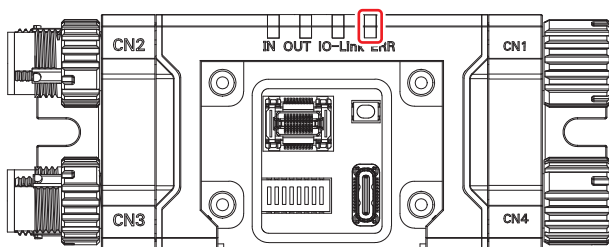

<Status of indicators at normal operation>
ERR: Not lit

If the ERR indicator is ON, turn off power of the Intelligent Tap and F3SG-SR/PG, make sure that the wiring is proper, and go back to step 3 to perform the steps again.

6. Connect a USB cable to the Intelligent Tap.

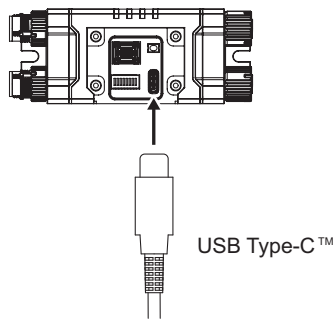

7. Connect the USB cable to the PC and run SD Manager 3.
8. Use SD Manager 3 to start the required monitoring function.
For detail of monitoring function, refer to 4-4. *Monitoring with SD Manager 3*.
9. Detach the USB cable from the Intelligent Tap.
10. Use a Phillips screwdriver to attach the cover of the Intelligent Tap.
(Recommended tightening torque: 0.35N·m)

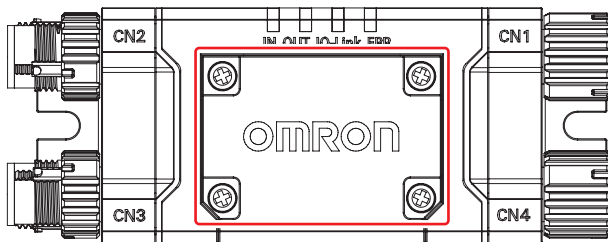

- To finish the maintenance task and start normal operation of the facility, perform the followings.

1. If a cable is not attached to CN3, use the torque wrench XY2F-0004 to attach the accessory waterproof cover (for plug).
(Recommended tightening torque for waterproof cover plug: 0.39 to 0.49N·m)
2. If a cable is not attached to CN4, attach the accessory waterproof cover (for socket).

- After configuring the settings, if you need to detach the Intelligent Tap from the facility, use the following steps.

1. Turn off power of the Intelligent Tap and F3SG-SR/PG.
2. Remove the Intelligent Tap and restore the wiring before configuring the settings.

4-6-4. Changing settings and/or monitoring status of multiple F3SG-SR/PG setting/status using one Intelligent Tap and SD Manager 3

■ Work steps

1. Connect the Intelligent Tap to the PC



- To prevent operational errors, do not connect the Intelligent Tap to the F3SG-SR/PG at this point.
- For connection instructions, refer to sections 4-1-3-2. *Connection Procedure When Using USB Connector*, and 4-1-3-3. *Connection Procedure When Using Bluetooth® Communication Unit (F39-SGBT)*.

2. Initialize the Intelligent Tap

- 2.1. Start SD Manager 3.
- 2.2. Initialize the Intelligent Tap.
- 2.3. Shut down SD Manager 3.



- Refer to section 4-3-6. *Setting Initialization*, for the initialization procedure.

3. Configuration Process for each F3SG-SR/PG unit (Repeat the steps below for each required unit)

3.1. Sensor setting

- 3.1.1 Connect the F3SG-SR/PG unit to the Intelligent Tap and turn on the power.
- 3.1.2 Start SD Manager 3.
- 3.1.3 Make configuration changes and monitor the status on the unit using the F3SG-SR/PG.
- 3.1.4 Shut down SD Manager 3.
- 3.1.5 Turn off the power of the F3SG-SR/PG unit and disconnect the cable between the F3SG-SR/PG and the Intelligent Tap.

3.2. Initialize the Intelligent Tap

- 3.2.1 Start SD Manager 3.
- 3.2.2 Initialize the Intelligent Tap
- 3.2.3 Shut down SD Manager 3.

4. Remove the Intelligent Tap from the PC.



- By disabling The Backup/Restoration function of the F3SG-SR/PG in advance, you can skip the need to initialize the Intelligent Tap each time.

CHECK! For the procedure to disable the backup/restore function, refer to section 4-3-7. *Backup/Restoration*.

■ To finish the maintenance task and start normal operation of the facility, perform the followings.

1. If a cable is not attached to CN3, use the torque wrench XY2F-0004 to attach the accessory waterproof cover (for plug).
(Recommended tightening torque for waterproof cover plug: 0.39 to 0.49N·m)
2. If a cable is not attached to CN4, attach the accessory waterproof cover (for socket).

■ After configuring the settings, if you need to detach the Intelligent Tap from the facility, use the following steps.

1. Turn off power of the Intelligent Tap and F3SG-SR/PG.

2. Remove the Intelligent Tap and restore the wiring before configuring the settings.

Chapter 5 Wiring and Installation

5-1. Installation Considerations	306
5-1-1. Detection Zone and Approach	306
5-1-2. Safety Distance	308
5-1-2-1. Safety Distance Formulas according to ISO 13855/EN ISO 13855	308
5-1-2-2. Safety Distance Formulas according to ANSI B11.19	312
5-1-3. Distance from Reflective Surfaces	313
5-1-3-1. F3SG-SR/PG (Type 2 ESPE)	313
5-1-4. Mutual Interference Prevention	314
5-2. Dimensions	315
5-2-1. F3SG-SR Series	315
5-2-1-1. Mounted with Side-Mount Brackets (Intermediate Brackets) (F39-LSGF)	315
5-2-1-2. Mounted with Adjustable Side-Mount Brackets (Intermediate Brackets) (F39-LSGA)	317
5-2-1-3. Mounted with Adjustable Top/Bottom Brackets (F3SJ, F3SN Adapter) (F39-LSGTB-SJ) and Side-Mount Brackets (Intermediate Brackets) (F39-LSGF)	319
5-2-1-4. Mounted with Adjustable Top/Bottom Brackets (F3SJ, F3SN Adapter) (F39-LSGTB-SJ) and Adjustable Side-Mount Brackets (Intermediate Brackets) (F39-LSGA)	321
5-2-2. F3SG-PG Series	323
5-2-2-1. Mounted with Side-Mount Brackets (Intermediate Brackets) (F39-LSGF)	323
5-2-2-2. Mounted with Adjustable Side-Mount Brackets (Intermediate Brackets) (F39-LSGA)	325
5-2-2-3. Mounted with Adjustable Top/Bottom Brackets (F3SJ, F3SN Adapter) (F39-LSGTB-SJ) and Side-Mount Bracket (Intermediate Bracket) (F39-LSGF)	327
5-2-2-4. Mounted with Adjustable Top/Bottom Brackets (F3SJ, F3SN Adapter) (F39-LSGTB-SJ) and Adjustable Side-Mount Bracket (Intermediate Bracket) (F39-LSGA)	329
5-2-3. Bracket	331

5-2-3-1. Side-Mount Bracket (Intermediate Bracket) (F39-LSGF sold, separately)	331
5-2-3-2. Adjustable Side-Mount Bracket (Intermediate Bracket) (F39-LSGA, sold separately)	331
5-2-3-3. Adjustable Top/Bottom Bracket (F3SJ, F3SN Adapter) (F39-LSGTB-SJ, sold separately)	331
5-2-3-4. Adjustable Top/Bottom Bracket (F3SG-RA/RE Adapter) (F39-LSGTB-RE, sold separately)	332
5-2-3-5. Adjustable Top/Bottom Bracket (MS4800, F3SR Adapter) (F39-LSGTB-MS, sold separately)	332
5-2-4. Intelligent Tap	333
5-2-5. Intelligent Tap Bracket	333
5-2-6. Bluetooth® Communication Unit	335
5-2-7. Spatter Protection Cover	336
5-2-8. Laser Alignment Pointer	337
5-2-9. Lamps	338
5-2-10. Muting Sensor Arm Mounter	339
5-2-11. Floor Mounting Column	340
5-2-12. Mirror Columns	342
5-2-13. IP69K Model	344
5-3. Mounting	346
5-3-1. Mounting Method	346
5-3-2. Number of Brackets Required	346
5-3-3. Proper Mounting	347
5-3-3-1. Proper Mounting Orientation	347
5-3-4. Mounting Procedure	349
5-3-4-1. Mounting with Side-Mount Brackets (Intermediate Brackets) (F39-LSGF)	349
5-3-4-2. Mounting with Adjustable Side-Mount Brackets (Intermediate Brackets) (F39-LSGA)	350
5-3-4-3. Mounting with Adjustable Top/Bottom Brackets (F3SJ, F3SN Adapter) (F39-LSGTB-SJ) and Side-Mount Brackets (Intermediate Brackets) (F39-LSGF)	354
5-3-4-4. Mounting with Adjustable Top/Bottom Brackets (F3SJ, F3SN Adapter) (F39-LSGTB-SJ) and Adjustable Side-Mount Brackets (Intermediate Brackets) (F39-LSGA)	358
5-3-4-5. Mounting IP69K Model	363
5-4. Wiring	367
5-4-1. Wiring Precautions	367
5-4-2. Power Supply Unit	368

5-4-3. Cable Connections	369
5-4-3-1. Root-Straight Cable	371
5-4-3-2. Root-Plug Cable for Extended	372
5-4-3-3. Extended Socket-Straight Cable	373
5-4-3-4. Extended Plug-Socket Cable	374
5-4-3-5. Cascading Cable for Extended	376
5-4-3-6. Side-by-side Cascading Cable	377
5-4-3-7. F3SJ-A/B Conversion Cable	378
5-4-3-8. F3SG-RE Conversion Cable	380
5-4-3-9. MS48 Conversion Cable	381
5-4-3-10. F3SJ-A/B-TS/T, F3SG-RA-TS Conversion Cable	382
5-4-3-11. Extending Cable Length with Commercially Available Cable	383
5-4-3-12. Reduced Wiring Connector System with Y-Joint Plug/Socket Connector	384
5-4-3-13. Easy Wiring Connector System with Reset Switch Connector	385
5-4-3-14. Reduced Wiring System with Muting Connector Box	387
5-4-3-15. Wiring of IP69K Model	389
5-4-3-16. Intelligent Tap-to-IO-Link Master Cable	390
5-4-4. Functional Earth Connection	391
5-5. Cascade Connection	392
5-5-1. Overview	392
5-5-2. Connection Procedure	394

5-1. Installation Considerations

5-1-1. Detection Zone and Approach

WARNING

Install a protective structure so that the hazardous part of a machine can only be reached by passing through the sensor's detection zone. If access to the hazardous part by reaching over the detection zone of a vertically mounted F3SG-SR/PG cannot be excluded, the height of the detection zone and the safety distance shall be determined in consideration of such a risk. Install the sensors so that part of the person is always present in the detection zone when working in a machine's hazardous zones. If a person is able to step into the hazardous zone of a machine and remain behind the F3SG-SR/PG's detection zone, configure the system with Restart Interlock function. Failure to do so may result in serious injury due to unexpected startup.



Do not use this sensor for machines that cannot be stopped quickly by electrical control. For example, do not use it for a pressing machine that uses full-rotation clutch. Otherwise, the machine may not stop before a person reaches the hazardous part, resulting in serious injury.



To use the F3SG-SR in PSDI mode (initiation of cyclic operation by a presence sensing device), you must configure an appropriate circuit between the F3SG-SR and the machine. For details about PSDI, refer to OSHA 1910.217, IEC 61496-1, and other relevant standards and regulations.



Install the reset switch in a location that provides a clear view of the entire hazardous zone and where it cannot be activated from within the hazardous zone.



Install the pre-reset switch always in the hazardous zone and where it cannot be activated from outside the hazardous zone.



Do not use the product in environments where flammable or explosive gases are present. Doing so may result in explosion.



The F3SG-SR/PG cannot protect a person from an object flying from the hazardous zone. Install protective cover(s) or fence(s).



Correct installation

The hazardous zone of a machine can be reached only by passing through the sensor's detection zone.



While working, a person is inside the sensor's detection zone.



Safety distance reflects the possible access to the hazardous zone by reaching over the detection zone.

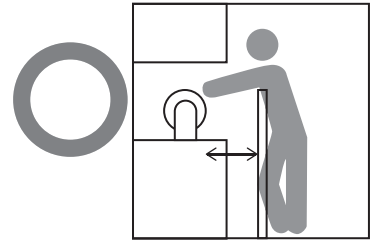

Incorrect installation

It is possible to reach the hazardous zone of a machine without passing through the sensor's detection zone.



A person is between the sensor's detection zone and the hazardous zone of a machine.

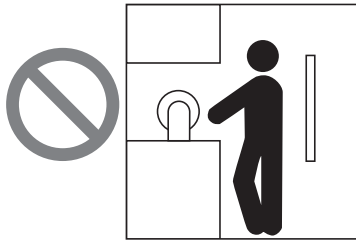

It is possible to access the hazardous zone by reaching over the detection zone.



5-1-2. Safety Distance

The safety distance is the distance that must be set between the F3SG-SR/PG and a machine's hazardous part to stop the hazardous part before a person or object reaches it. The safety distance varies according to the standards of each country and the individual specifications of each machine. Always refer to the relevant standards.

⚠ WARNING

Make sure to install the F3SG-SR/PG at the safety distance from the hazardous part of the machine. Otherwise, the machine may not stop before a person reaches the hazardous part, resulting in serious injury.



The response time of a machine is the time period from when the machine receives a stop signal to when the machine's hazardous part stops. Measure the response time on the actual system. Also, periodically check that the response time of the machine has not changed.

5-1-2-1. Safety Distance Formulas according to ISO 13855/EN ISO 13855

■ Detection Zone Orthogonal to Direction of Approach

$S = K \times T + C$. . . Formula (1)

- S: Safety distance
- K: Approach speed to the detection zone
- T: Total response time of the machine and the F3SG-SR/PG
- C: Additional distance calculated by the detection capability (or object resolution) of the F3SG-SR

Calculation Example for Systems with a Detection Capability or a Beam Gap of 40 mm or Less

Use $K = 2,000 \text{ mm/s}$ and $C = 8 \times (d - 14 \text{ mm})$ in formula (1) for the calculation.

$S = 2,000 \text{ mm/s} \times (T_m + T_s) + 8 \times (d - 14 \text{ mm})$

- S = Safety distance (mm)
- T_m = Machine's response time (s)
- T_s = Response time of the F3SG-SR from ON to OFF (s)
- d = Detection capability (or object resolution) of the F3SG-SR (mm)

[Calculation example]

When $T_m = 0.05 \text{ s}$, $T_s = 0.008 \text{ s}$, and $d = 14 \text{ mm}$:

$S = 2,000 \text{ mm/s} \times (0.05 \text{ s} + 0.008 \text{ s}) + 8 \times (14 \text{ mm} - 14 \text{ mm})$
 $= 116 \text{ mm}$. . . Formula (2)

If the result $< 100 \text{ mm}$, use $S = 100 \text{ mm}$.

If the result exceeds 500 mm , use the following expression where $K = 1,600 \text{ mm/s}$.

$S = 1,600 \text{ mm/s} \times (T_m + T_s) + 8 \times (d - 14 \text{ mm})$. . . Formula (3)

If the result of this formula (3) $< 500 \text{ mm}$, use $S = 500 \text{ mm}$.

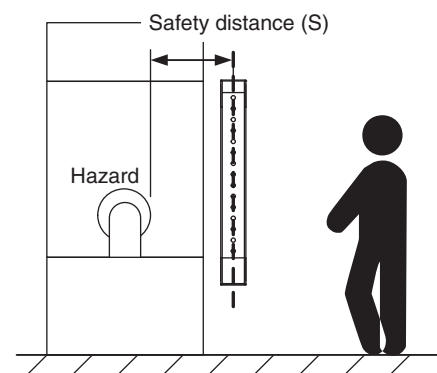

Calculation Example for Systems with a Detection Capability or a Beam Gap of over 40 mm and 70 mm or Less

Use $K = 1,600 \text{ mm/s}$ and $C = 850 \text{ mm}$ in formula (1) for calculation.

$$S = 1,600 \text{ mm/s} \times (T_m + T_s) + 850 \dots \text{Formula (4)}$$

- S = Safety distance (mm)
- T_m = Machine's response time (s)
- T_s = Response time of the F3SG-SR/PG from ON to OFF (s)

[Calculation example]

When $T_m = 0.05 \text{ s}$ and $T_s = 0.008 \text{ s}$:

$$\begin{aligned} S &= 1,600 \text{ mm/s} \times (0.05 \text{ s} + 0.008 \text{ s}) + 850 \text{ mm} \\ &= 942.8 \text{ mm} \end{aligned}$$

Calculation Example for Systems with a Detection Capability or a Beam Gap of over 70 mm

If the risk assessment indicates that F3SG-SR/PG is appropriate, use formula (4) for the calculation.

■ Possible Circumventing by Reaching Over the Detection Zone

If access to the hazardous zone by reaching over the detection zone of vertically mounted F3SG-SR/PG cannot be excluded, the height and the safety distance, S , of the F3SG-SR/PG shall be determined. S shall be determined by comparison of the calculated values in ■ *Detection Zone Orthogonal to Direction of Approach*. The greater value resulting from this comparison shall be applied.

$$S = (K \times T) + C_{ro} \dots \text{Formula (5)}$$

- S : Safety distance
- K : Approach speed to the detection zone
- T : Total response time of the machine and the F3SG-SR/PG
- C_{ro} : Approach distance based on the distance which personnel can move towards the hazardous zone of a machine by reaching over the detection zone. The distance is determined in the table below based on the height of the hazardous zone, a , and the height of the upper edge of the detection zone, b .

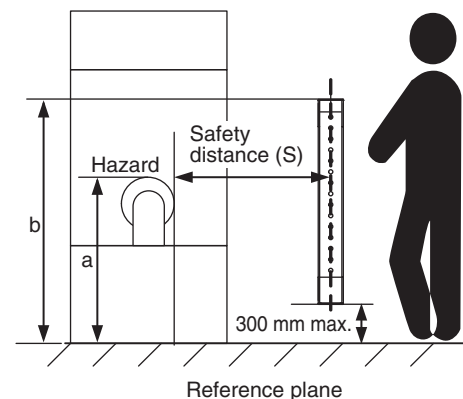

Note: Lower edge of the detection zone above 300 mm in relation to the reference plane does not offer sufficient protection against crawling below.

First, use $K = 2,000 \text{ mm/s}$ in formula (5) for the calculation. If the result of this calculation is less than 100 mm, use $S = 100 \text{ mm}$.

If the result exceeds 500 mm, use $K = 1,600 \text{ mm/s}$ to recalculate it. If the result of the recalculation is less than 500 mm, use $S = 500 \text{ mm}$.

Height of hazardous zone, a	Height of upper edge of detection zone, b											
	900	1000	1100	1200	1300	1400	1600	1800	2000	2200	2400	2600
	Additional distance to hazardous zone, Cro											
2600	0	0	0	0	0	0	0	0	0	0	0	0
2500	400	400	350	300	300	300	300	300	250	150	100	0
2400	550	550	550	500	450	450	400	400	300	250	100	0
2200	800	750	750	700	650	650	600	550	400	250	0	0
2000	950	950	850	850	800	750	700	550	400	0	0	0
1800	1100	1100	950	950	850	800	750	550	0	0	0	0
1600	1150	1150	1100	1000	900	850	750	450	0	0	0	0
1400	1200	1200	1100	1000	900	850	650	0	0	0	0	0
1200	1200	1200	1100	1000	850	800	0	0	0	0	0	0
1000	1200	1150	1050	950	750	700	0	0	0	0	0	0
800	1150	1050	950	800	500	450	0	0	0	0	0	0
600	1050	950	750	550	0	0	0	0	0	0	0	0
400	900	700	0	0	0	0	0	0	0	0	0	0
200	600	0	0	0	0	0	0	0	0	0	0	0
0	0	0	0	0	0	0	0	0	0	0	0	0

Note 1. Upper edge of the detection zone below 900 mm is not included since they do not offer sufficient protection against circumventing or stepping over.

Note 2. When determining the values of this table, it shall not be interpolated. If the known values a, b or Cro are between two values of this table, the greater safety distance shall be used.

[Calculation example]

- T: $T_m + T_s$ (s)
- T_m : Machine's response time (s)
- T_s : Response time of the F3SG-SR/PG from ON to OFF (s)
- a: Height of machine hazardous zone (mm)
- b: Height of upper edge of detection zone (mm)

When $T_m = 0.05$ s, $T_s = 0.008$ s, $a = 1,400$ mm, $b = 1,500$ mm:

From the table above, $C_{ro} = 850$ mm. Since b is between 1,400 mm and 1,600 mm, $b = 1,400$ mm which has the greater C_{ro} value, shall be used.

$$S = 2,000 \text{ mm/s} \times (0.05 \text{ s} + 0.008 \text{ s}) + 850 \text{ mm} \\ = 966 \text{ mm}$$

Since 966 mm is greater than 500 mm, use $K = 1,600$ mm/s and recalculate it.

$$S = 1,600 \text{ m/s} \times (0.05 \text{ s} + 0.008 \text{ s}) + 850 \text{ mm} \\ = 942.8 \text{ mm}$$

Compare $S = 942.8$ mm with the calculation for Detection Zone Orthogonal to Direction of Approach, and choose the larger value as the safety distance.

For the system with a detection capability or a Beam Gap of over 40 mm and 70 mm or Less, the safety distance S is 942.8 mm since this is larger than $S = 116$ mm calculated in the calculation example of **■ Detection Zone Orthogonal to Direction of Approach**.

For the system with a detection capability larger than 40 mm, the safety distance S is 942.8 mm since this is the same value as $S = 942.8$ mm calculated in the calculation example of Detection Zone Orthogonal to Direction of Approach.

 Refer to *Detection Zone Orthogonal to Direction of Approach* under 5-1-2-1. *Safety Distance Formulas according to ISO 13855/EN ISO 13855*.

■ Detection Zone Parallel to Direction of Approach

Use $K = 1,600 \text{ mm/s}$ and $C = (1200 - 0.4 \times H)$ in formula (1) for calculation. Note that C must not be less than 850 mm.

$$S = 1,600 \text{ mm/s} \times (T_m + T_s) + 1200 - 0.4 \times H$$

- S = Safety distance (mm)
- T_m = Machine's response time (s)
- T_s = Response time of the F3SG-SR/PG from ON to OFF (s)
- H = Installation height (mm)

Note that H must satisfy:

$$1000 \geq H \geq 15 \text{ (d - 50 mm)} \geq 0 \text{ mm}$$

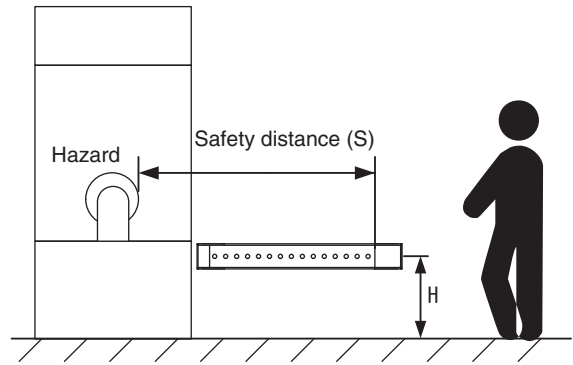

Also, you must include a hazardous condition under which a person may go through under a detection zone if H exceeds 300 mm (200 mm for other purpose than industrial use) into risk assessment.

[Calculation example]

When $T_m = 0.05 \text{ s}$, $T_s = 0.008 \text{ s}$, and $d = 14 \text{ mm}$:

$$S = 1,600 \text{ mm/s} \times (0.05 \text{ s} + 0.008 \text{ s}) + 1200 - 0.4 \times 500 \text{ mm} = 1092.8 \text{ mm}$$

When a warning zone is configured as in the figure, you must calculate L , a distance from an end of casing to a detection zone, using a formula below:

$$L = (\text{Total number of F3SG-SR/PG beams} - \text{number of warning zone beams} - 1) \times P + 10$$

- P : Beam Gap (mm)

 Refer to 1-6-1. List of Models and Response Times for total number of F3SG-SR/PG beams.

 Refer to 1-5. Ratings and Specifications for beam gap.

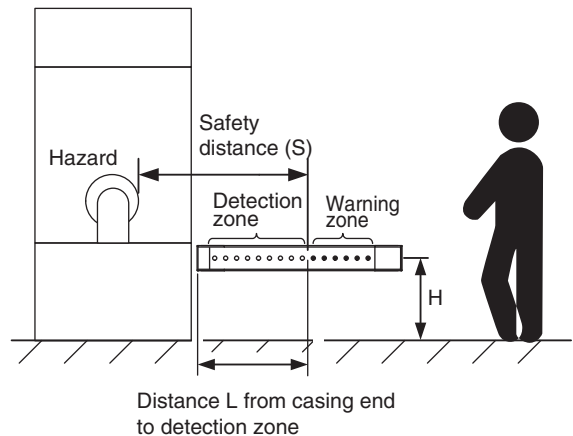

5-1-2-2. Safety Distance Formulas according to ANSI B11.19

If a person approaches the detection zone of the F3SG-SR/PG orthogonally, calculate the safety distance as shown below.

$$S = K \times (T_s + T_c + T_r + T_{bm}) + D_{pf}$$

- S: Safety distance
- K: Approach speed to the detection zone (the value recommended by OSHA standard is 1,600 mm/s)
Approach speed K is not specified in the ANSI B.11.19 standard. To determine the value of K to apply, consider all factors, including the operator's physical ability.
- T_s = Machine's stopping time (s)
- T_r = Response time of the F3SG-SR/PG from ON to OFF (s)
- T_c = Machine control circuit's maximum response time required to activate its brake (s)
- T_{bm} = Additional time (s)

If a machine has a brake monitor, " T_{bm} = Brake monitor setting time - ($T_s + T_c$)". If it has no brake monitor, we recommend using 20% or more of ($T_s + T_c$) as additional time.

- D_{pf} = Additional distance

According to ANSI's formula, D_{pf} is calculated as shown below:

$D_{pf} = 3.4 \times (d - 7.0)$: Where d is the detection capability (or object resolution) of the F3SG-SR/PG (unit: mm)

[Calculation example]

When $K = 1,600$ mm/s, $T_s + T_c = 0.06$ s, brake monitor setting time = 0.1 s,

$T_r = 0.008$ s, and $d = 14$ mm:

$$T_{bm} = 0.1 - 0.06 = 0.04 \text{ s}$$

$$D_{pf} = 3.4 \times (14 - 7.0) = 23.8 \text{ mm}$$

$$S = 1,600 \times (0.06 + 0.008 + 0.04) + 23.8 = 196.6 \text{ mm}$$

5-1-3. Distance from Reflective Surfaces

⚠ WARNING

Install the F3SG-SR/PG so that it is not affected by reflective surfaces. Failure to do so may hinder detection, resulting in serious injury.



Install the sensor system at distance D or further from highly reflective surfaces such as metallic walls, floors, ceilings, or workpieces, as shown below.

F3SG-SR/PG (Type 4 ESPE)

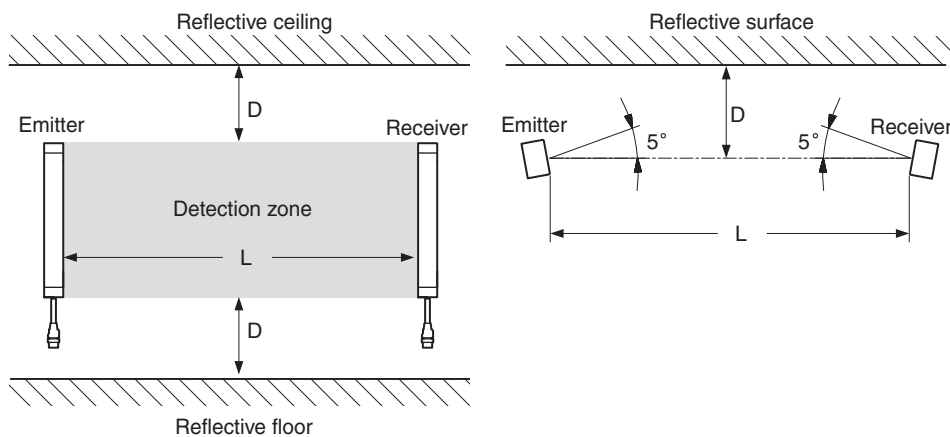

Distance between an emitter and a receiver (operating range L)	Allowable installation distance D
0.3 to less than 3 m	0.13 m
3 m or more	$L/2 \times \tan 5^\circ = L \times 0.044 \text{ m}$

5-1-3-1. F3SG-SR/PG (Type 2 ESPE)

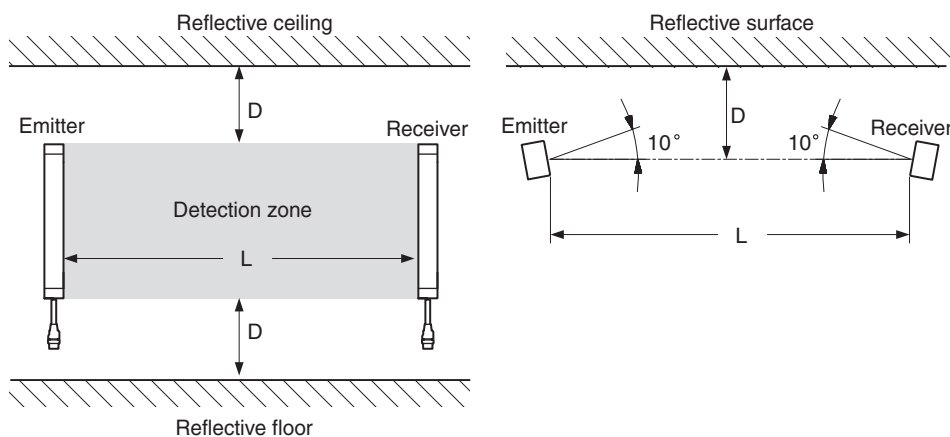

Distance between an emitter and a receiver (operating range L)	Allowable installation distance D
0.3 to less than 3 m	0.26 m
3 m or more	$L/2 \times \tan 10^\circ = L \times 0.089 \text{ m}$

5-1-4. Mutual Interference Prevention

⚠ WARNING

Do not use the F3SG-SR/PG with mirrors in a retro-reflective configuration. Doing so may hinder detection. It is possible to use mirrors to alter the detection zone to a 90-degree angle.



When using more than one set of F3SG-SR/PG's in adjacent areas, the emitter of one F3SG-SR/PG may interfere with the receiver of the other, causing the safety functions to stop working properly. Install, configure and maintain them so that mutual interference does not occur.



When two or more F3SG-SR/PG systems are mounted in close proximity to each other, precautions should be taken to avoid one system interfering with another, such as by beam alignment, back-to-back configuration, physical barrier, Scan Code Selection, Operating Range Selection or adjusting the distances from adjacent safety light curtains.

■ Example

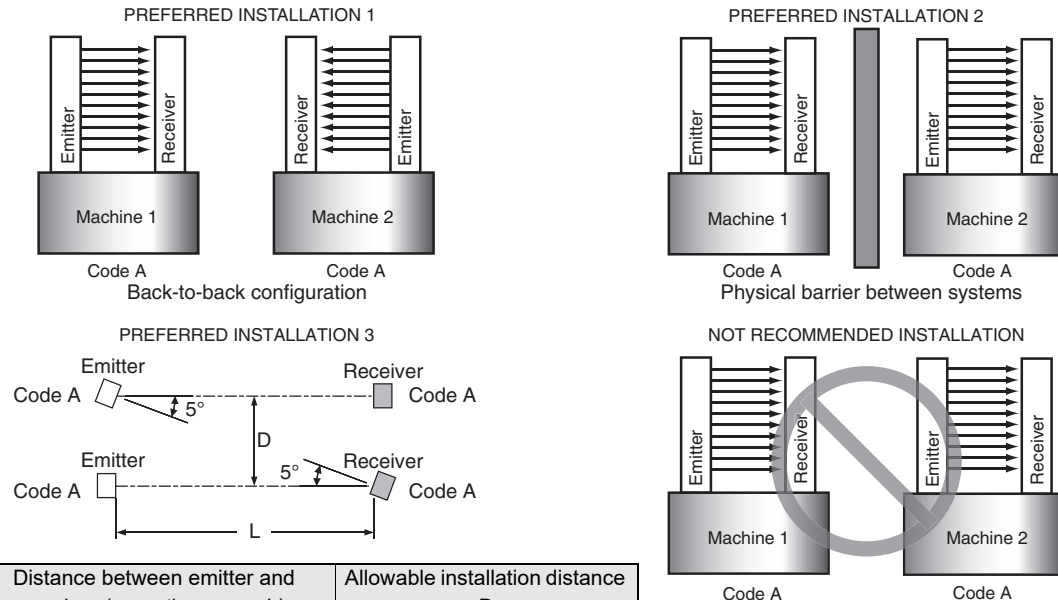

Distance between emitter and receiver (operating range L)	Allowable installation distance D
For 0.2 to 3m	0.26m
For 3m or more	$L \times \tan 5^\circ = L \times 0.088$ (m)

In the Wired Synchronization, mutual interference is prevented in up to 3 sets, using interference light avoidance algorithm.

In the Optical Synchronization, the scan code feature allows for placement of up to 2 sets of the F3SG-SR/PG in close proximity and in line with each other. The distinctive coding of the beams provide for unique operation of a system while in view of another system with a different scan code. Two unique codes are available.

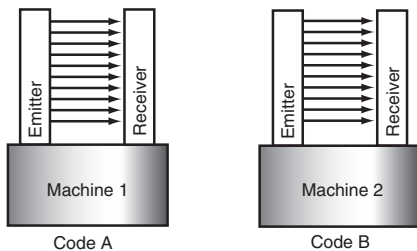

Scan code setting when two or more systems are mounted

The emitter and receiver units must be set to the same scan code for the receiver to enter the MACHINE RUN state. The scan code is selectable by the End Caps on the emitter and receiver units.

Refer to ■ Scan Code Selection under 2-3-1-1. *Optical Synchronization* for more information on the scan code feature.

5-2. Dimensions

5-2-1. F3SG-SR Series

5-2-1-1. Mounted with Side-Mount Brackets (Intermediate Brackets) (F39-LSGF)

■ Backside Mounting

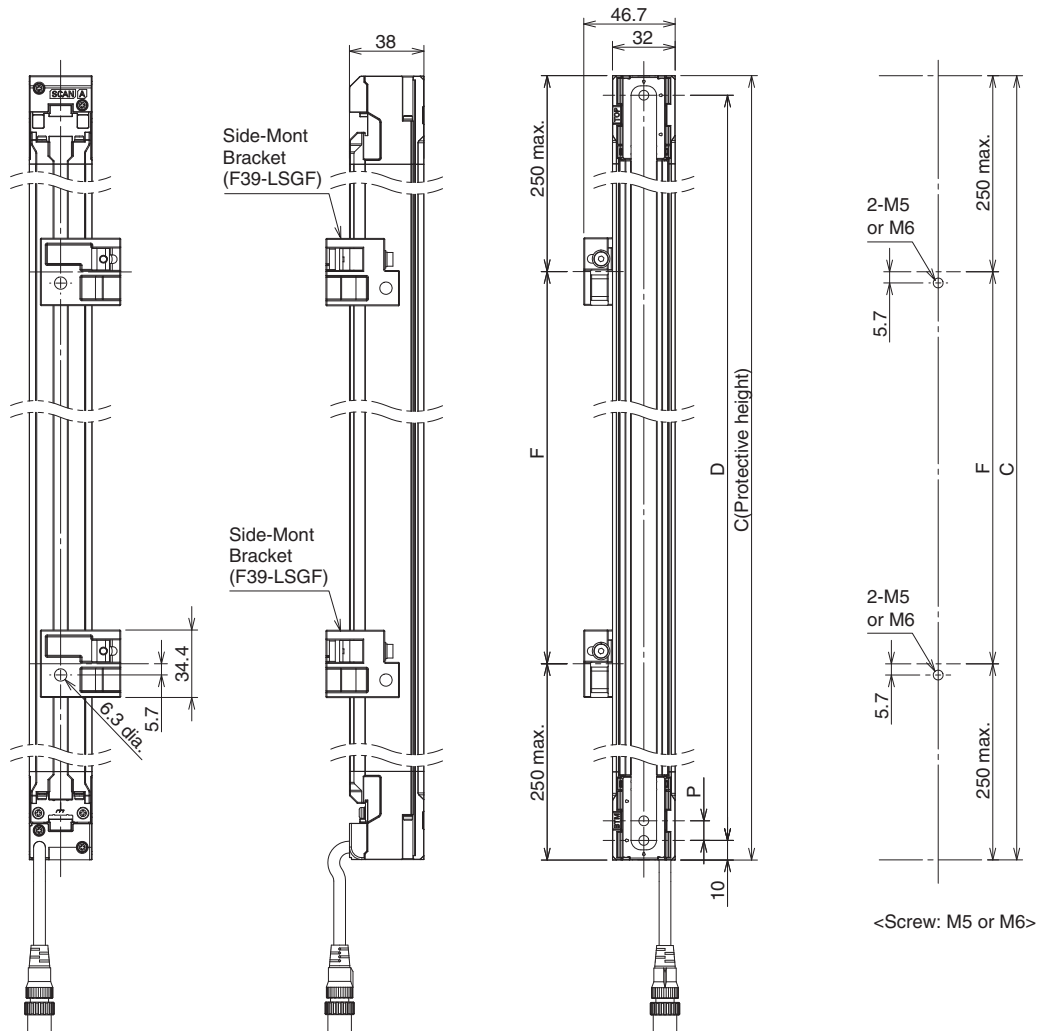

Dimension C	4-digit number of the type name (Protective height: Δ)	
Dimension D	F3SG-□SR□△△△△-14	C-20
	F3SG-□SR□△△△△-25	
	F3SG-□SR□△△△△-45	
Dimension P	F3SG-□SR□△△△△-85	C-40
	F3SG-□SR□△△△△-14	
	F3SG-□SR□△△△△-25	
	F3SG-□SR□△△△△-45	40
	F3SG-□SR□△△△△-85	80

Protective height (Dimension C)	Number of Side-Mount Bracket *	Dimension F
0160 to 1440	2	1000 mm max.
1520 to 2480	3	1000 mm max.

* The number of brackets required to mount either one of emitter and receiver.

5-3-4-1. Mounting with Side-Mount Brackets (Intermediate Brackets) (F39-LSGF)

- Use the brackets of specified quantities and locations according to the dimensions. The other brackets than described above may not meet the specified ratings and performance.
 - When you use the sensor in a situation where the sensor is under a load, increase the number of the brackets used.
- CHECK!** - Beam alignment cannot be performed with Side-Mount Brackets.

[Unit : mm]

■ Side Mounting

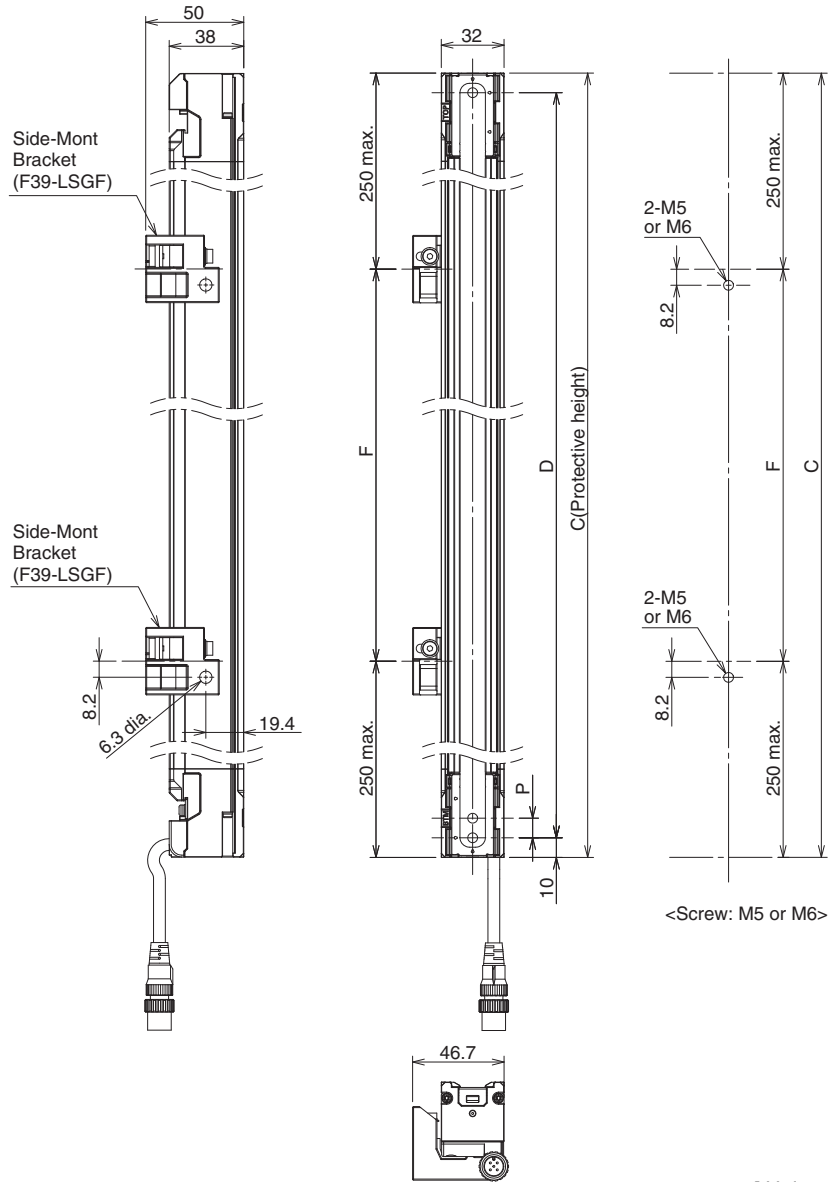

[Unit : mm]

Dimension C	4-digit number of the type name (Protective height: Δ)	
Dimension D	F3SG-□SR□△△△△-14	C-20
	F3SG-□SR□△△△△-25	
	F3SG-□SR□△△△△-45	C-40
	F3SG-□SR□△△△△-85	
Dimension P	F3SG-□SR□△△△△-14	10
	F3SG-□SR□△△△△-25	20
	F3SG-□SR□△△△△-45	40
	F3SG-□SR□△△△△-85	80

Protective height (Dimension C)	Number of Side-Mount Bracket *	Dimension F
0160 to 1440	2	1000 mm max.
1520 to 2480	3	1000 mm max.

* The number of brackets required to mount either one of emitter and receiver.

5-3-4-1. Mounting with Side-Mount Brackets (Intermediate Brackets) (F39-LSGF)

- Use the brackets of specified quantities and locations according to the dimensions. The other brackets than described above may not meet the specified ratings and performance.
- When you use the sensor in a situation where the sensor is under a load, increase the number of the brackets used.
- CHECK!** - Beam alignment cannot be performed with Side-Mount Brackets.

5-2-1-2. Mounted with Adjustable Side-Mount Brackets (Intermediate Brackets) (F39-LSGA)

■ Backside Mounting

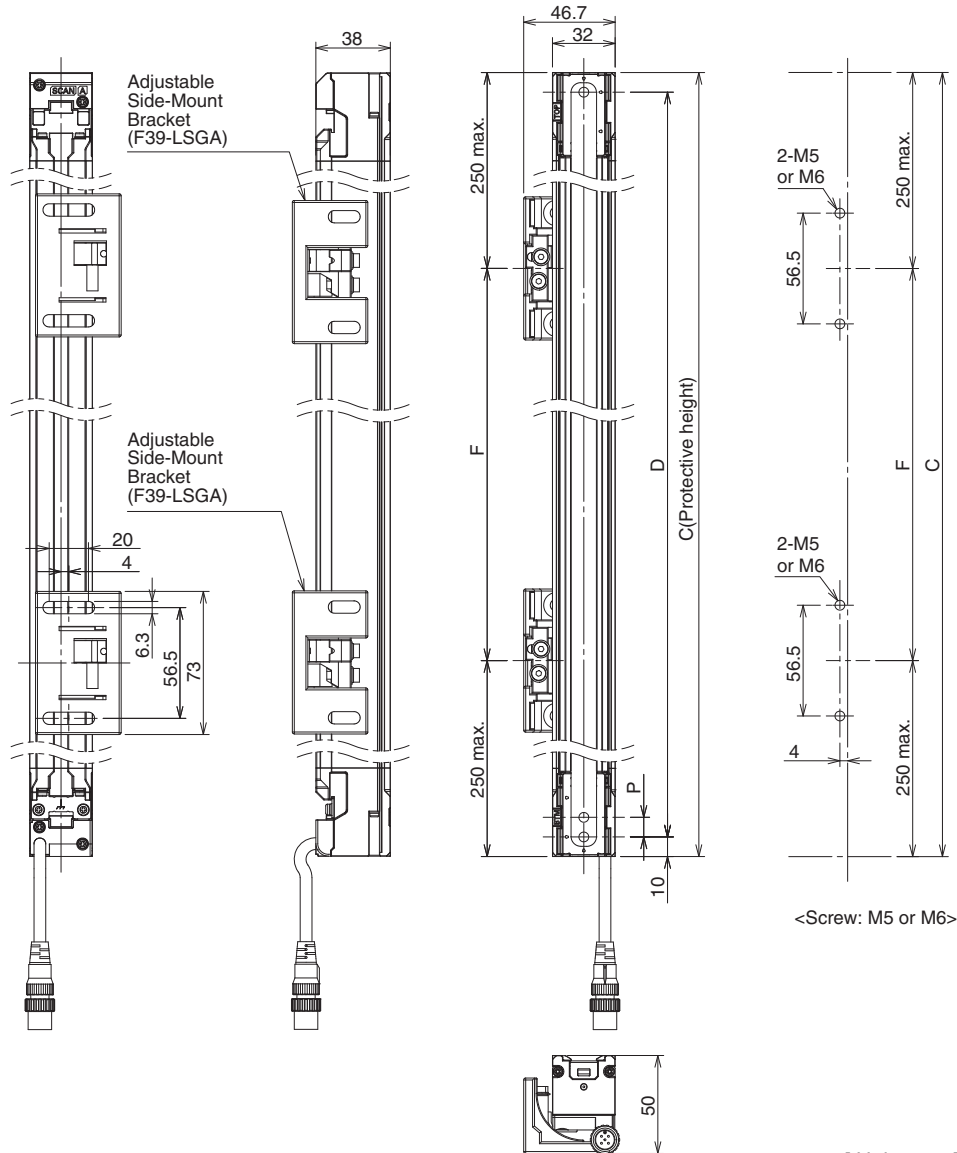

[Unit : mm]

Dimension C	4-digit number of the type name (Protective height: △)	
Dimension D	F3SG-□SR□△△△△-14	C-20
	F3SG-□SR□△△△△-25	
Dimension D	F3SG-□SR□△△△△-45	C-40
	F3SG-□SR□△△△△-85	
Dimension P	F3SG-□SR□△△△△-14	10
	F3SG-□SR□△△△△-25	20
	F3SG-□SR□△△△△-45	40
	F3SG-□SR□△△△△-85	80

Protective height (Dimension C)	Number of Adjustable Side-Mount Bracket *	Dimension F
0160 to 0280	1	-
0320 to 1440	2	1000 mm max.
1520 to 2480	3	1000 mm max.

*The number of brackets required to mount either one of emitter and receiver.

5-3-4-2. Mounting with Adjustable Side-Mount Brackets (Intermediate Brackets) (F39-LSGA)



- Use the brackets of specified quantities and locations according to the dimensions. The other brackets than described above may not meet the specified ratings and performance.

- When you use the sensor in a situation where the sensor is under a load, increase the number of the brackets used.

CHECK! - The Adjustable Side-Mount Bracket allows beam alignment after fixing the bracket to a wall surface. The angle adjustment range of the Adjustable Side-Mount Brackets is $\pm 15^\circ$.

■ Side Mounting

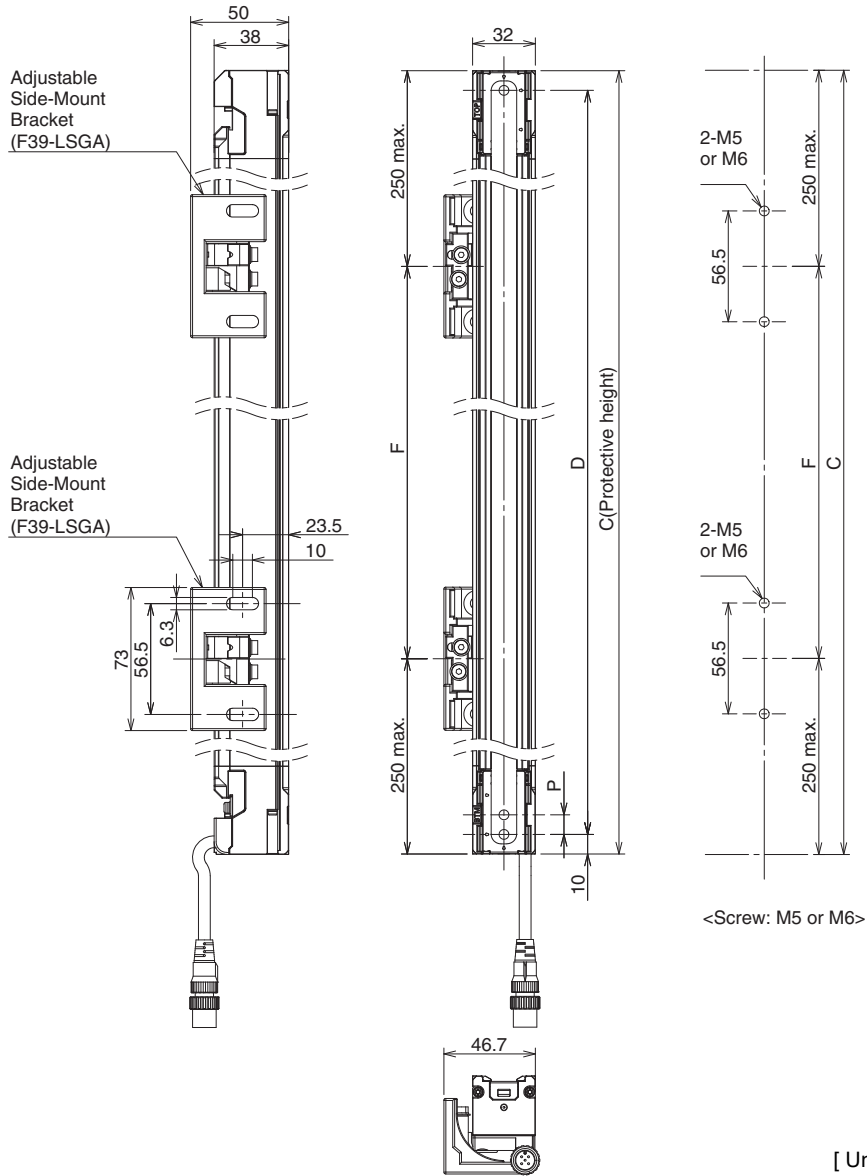

[Unit : mm]

Dimension C	4-digit number of the type name (Protective height: △)	
Dimension D	F3SG-□SR□△△△△-14	C-20
	F3SG-□SR□△△△△-25	
	F3SG-□SR□△△△△-45	C-40
	F3SG-□SR□△△△△-85	
Dimension P	F3SG-□SR□△△△△-14	10
	F3SG-□SR□△△△△-25	20
	F3SG-□SR□△△△△-45	40
	F3SG-□SR□△△△△-85	80

Protective height (Dimension C)	Number of Adjustable Side-Mount Bracket *	Dimension F
0160 to 0280	1	-
0320 to 1440	2	1000 mm max.
1520 to 2480	3	1000 mm max.

*The number of brackets required to mount either one of emitter and receiver.

5-3-4-2. Mounting with Adjustable Side-Mount Brackets (Intermediate Brackets) (F39-LSGA)

- Use the brackets of specified quantities and locations according to the dimensions. The other brackets than described above may not meet the specified ratings and performance.
- When you use the sensor in a situation where the sensor is under a load, increase the number of the brackets used.
- CHECK!** - The Adjustable Side-Mount Bracket allows beam alignment after fixing the bracket to a wall surface. The angle adjustment range of the Adjustable Side-Mount Brackets is ±15°.

5-2-1-3. Mounted with Adjustable Top/Bottom Brackets (F3SJ, F3SN Adapter) (F39-LSGTB-SJ) and Side-Mount Brackets (Intermediate Brackets) (F39-LSGF) ■ Backside Mounting

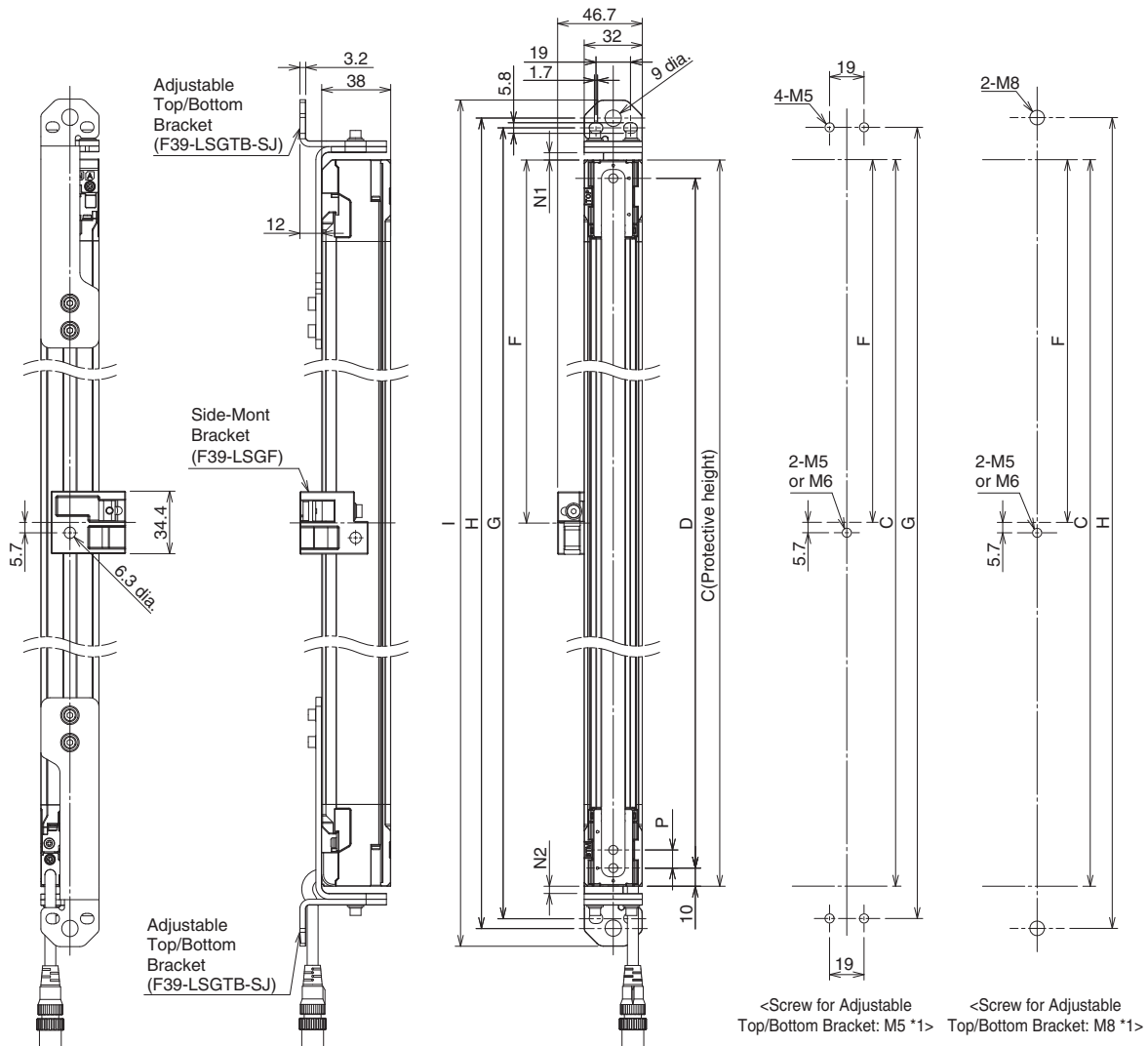

Dimension C	4-digit number of the type name (Protective height: Δ)	
Dimension D	F3SG-□SR□ $\Delta\Delta\Delta\Delta$ -14	C-20
	F3SG-□SR□ $\Delta\Delta\Delta\Delta$ -25	C-40
	F3SG-□SR□ $\Delta\Delta\Delta\Delta$ -45	
	F3SG-□SR□ $\Delta\Delta\Delta\Delta$ -85	
Dimension G	$C+27.2+N1+N2$	
Dimension H	$C+38+N1+N2$	
Dimension I	$C+58+N1+N2$	
Dimension N1	0 to 30 *2	
Dimension N2	0 to 30 *2	
Dimension P	F3SG-□SR□ $\Delta\Delta\Delta\Delta$ -14	10
	F3SG-□SR□ $\Delta\Delta\Delta\Delta$ -25	20
	F3SG-□SR□ $\Delta\Delta\Delta\Delta$ -45	40
	F3SG-□SR□ $\Delta\Delta\Delta\Delta$ -85	80

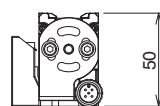

[Unit : mm]

Protective height (Dimension C)	Number of Adjustable Top/Bottom Bracket *3	Number of Intermediate Bracket *3	Dimension F
0160 to 0840	2	0	-
0880 to 1680	2	1	1000 mm max.
1760 to 2480	2	2	1000 mm max.

*1. Side-Mount Bracket: M5 or M6
 *2. For the model of protective height of 0160, the numbers corresponding to dimensions N1 and N2 are 26 to 30.
 *3. The number of brackets required to mount either one of emitter and receiver.

5-3-4-3. Mounting with Adjustable Top/Bottom Brackets (F3SJ, F3SN Adapter) (F39-LSGTB-SJ) and Side-Mount Brackets (Intermediate Brackets) (F39-LSGF)

- Use the brackets of specified quantities and locations according to the dimensions. The other brackets than described above may not meet the specified ratings and performance.
 - When you use the sensor in a situation where the sensor is under a load, increase the number of the brackets used.
- CHECK!** - Beam alignment cannot be performed in combination with Adjustable Top/Bottom Brackets and Side-Mount Brackets with the Brackets fixed to the wall surface.

■ Side Mounting

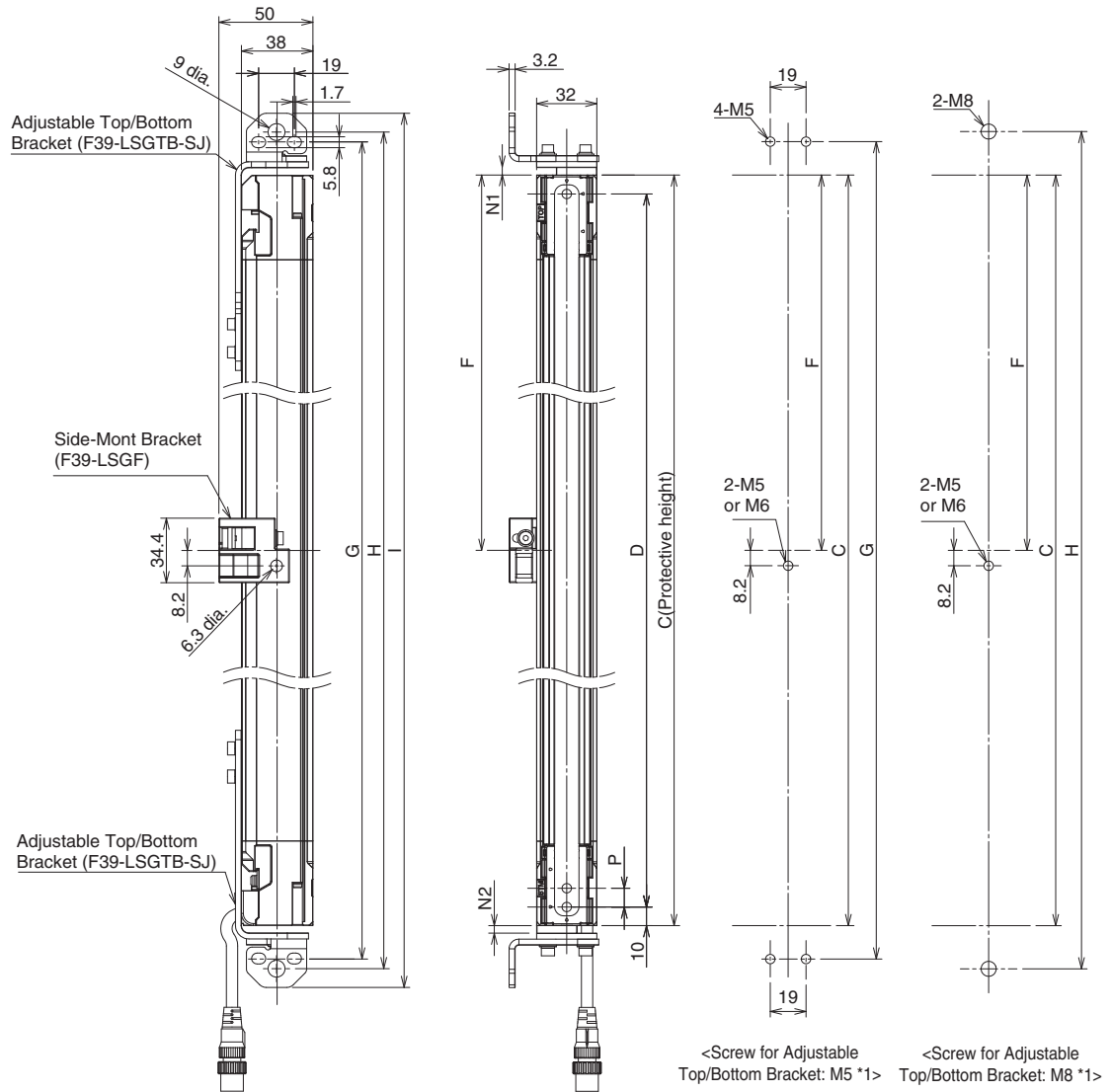

Dimension C	4-digit number of the type name (Protective height: Δ)	
Dimension D	F3SG-□SR□△△△△-14	C-20
	F3SG-□SR□△△△△-25	C-40
	F3SG-□SR□△△△△-45	
	F3SG-□SR□△△△△-85	
Dimension G	C+27.2+N1+N2	
Dimension H	C+38+N1+N2	
Dimension I	C+58+N1+N2	
Dimension N1	0 to 30 *2	
Dimension N2	0 to 30 *2	
Dimension P	F3SG-□SR□△△△△-14	10
	F3SG-□SR□△△△△-25	20
	F3SG-□SR□△△△△-45	40
	F3SG-□SR□△△△△-85	80

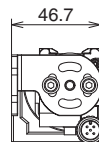

[Unit : mm]

Protective height (Dimension C)	Number of Adjustable Top/Bottom Bracket *3	Number of Intermediate Bracket *3	Dimension F
0160 to 0840	2	0	-
0880 to 1680	2	1	1000 mm max.
1760 to 2480	2	2	1000 mm max.

*1. Side-Mount Bracket: M5 or M6

*2. For the model of protective height of 0160, the numbers corresponding to dimensions N1 and N2 are 26 to 30.

*3. The number of brackets required to mount either one of emitter and receiver.



5-3-4-3. Mounting with Adjustable Top/Bottom Brackets (F3SJ, F3SN Adapter) (F39-LSGTB-SJ) and Side-Mount Brackets (Intermediate Brackets) (F39-LSGF)



- Use the brackets of specified quantities and locations according to the dimensions. The other brackets than described above may not meet the specified ratings and performance.
- When you use the sensor in a situation where the sensor is under a load, increase the number of the brackets used.

CHECK! - Beam alignment cannot be performed in combination with Adjustable Top/Bottom Brackets and Side-Mount Brackets with the Brackets fixed to the wall surface.

5-2-1-4. Mounted with Adjustable Top/Bottom Brackets (F3SJ, F3SN Adapter) (F39-LSGTB-SJ) and Adjustable Side-Mount Brackets (Intermediate Brackets) (F39-LSGA)

■ Backside Mounting

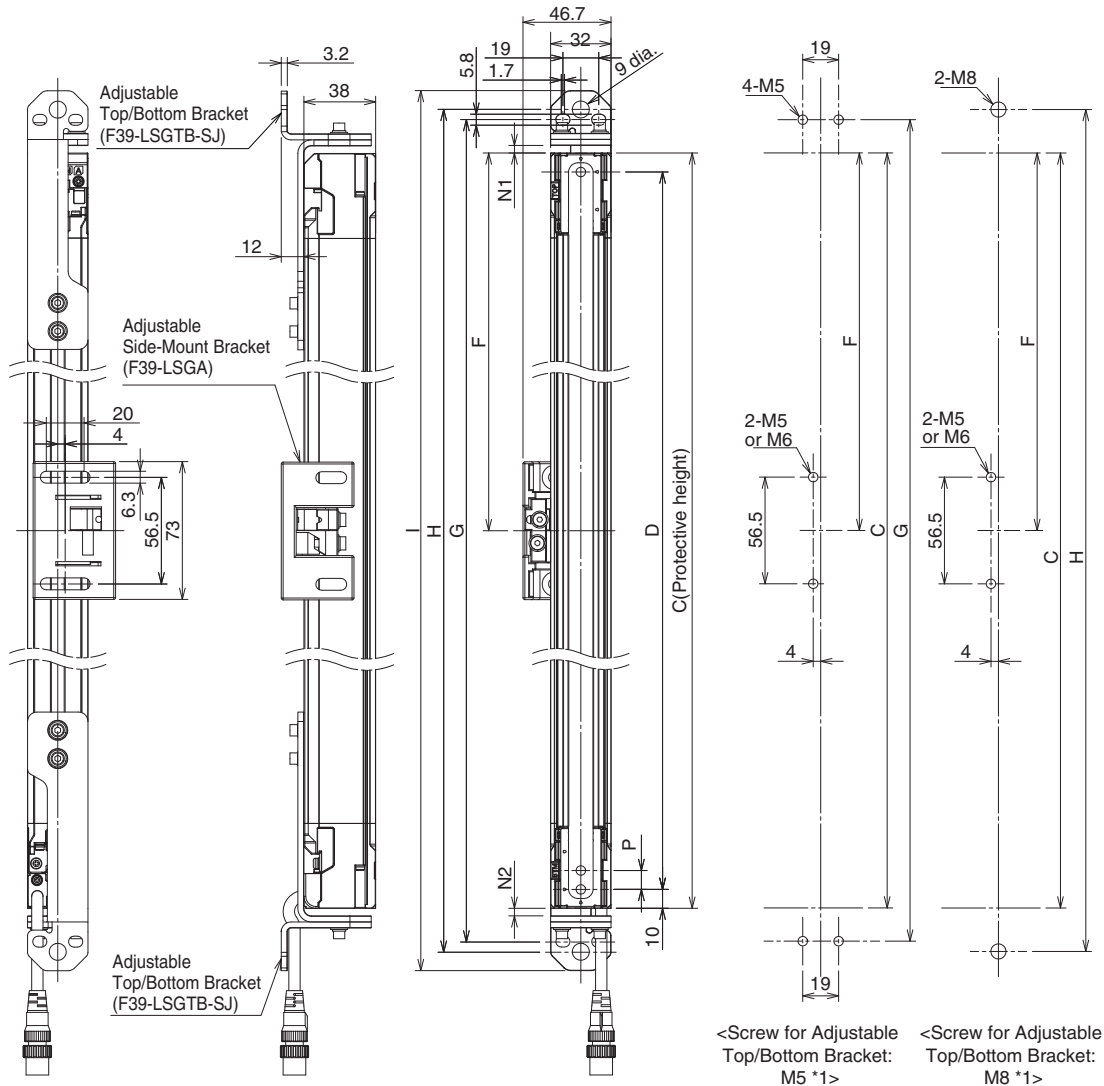

Dimension C	4-digit number of the type name (Protective height: Δ)	
Dimension D	F3SG-□SR□△△△△-14	C-20
	F3SG-□SR□△△△△-25	C-40
	F3SG-□SR□△△△△-45	
	F3SG-□SR□△△△△-85	
Dimension G	C+27.2+N1+N2	
Dimension H	C+38+N1+N2	
Dimension I	C+58+N1+N2	
Dimension N1	0 to 30 *2	
Dimension N2	0 to 30 *2	
Dimension P	F3SG-□SR□△△△△-14	10
	F3SG-□SR□△△△△-25	20
	F3SG-□SR□△△△△-45	40
	F3SG-□SR□△△△△-85	80

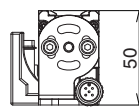

[Unit : mm]

Protective height (Dimension C)	Number of Adjustable Top/Bottom Bracket *3	Number of Intermediate Bracket *3	Dimension F
0160 to 0840	2	0	-
0880 to 1680	2	1	1000 mm max.
1760 to 2480	2	2	1000 mm max.

*1. Adjustable Side-Mount Bracket: M5 or M6
 *2. For the model of protective height of 0160, the numbers corresponding to dimensions N1 and N2 are 26 to 30.
 *3. The number of brackets required to mount either one of emitter and receiver.

5-3-4-4. Mounting with Adjustable Top/Bottom Brackets (F3SJ, F3SN Adapter) (F39-LSGTB-SJ) and Adjustable Side-Mount Brackets (Intermediate Brackets) (F39-LSGA)

- Use the brackets of specified quantities and locations according to the dimensions. The other brackets than described above may not meet the specified ratings and performance.
 - When you use the sensor in a situation where the sensor is under a load, increase the number of the brackets used.
- CHECK!** - The Adjustable Top/Bottom Bracket and Adjustable Side-Mount Bracket allow beam alignment after fixing the bracket to a wall surface. The angle adjustment range of the Adjustable Top/Bottom Brackets is $\pm 22.5^\circ$. The angle adjustment range of the Adjustable Side-Mount Brackets is $\pm 15^\circ$.

■ Side Mounting

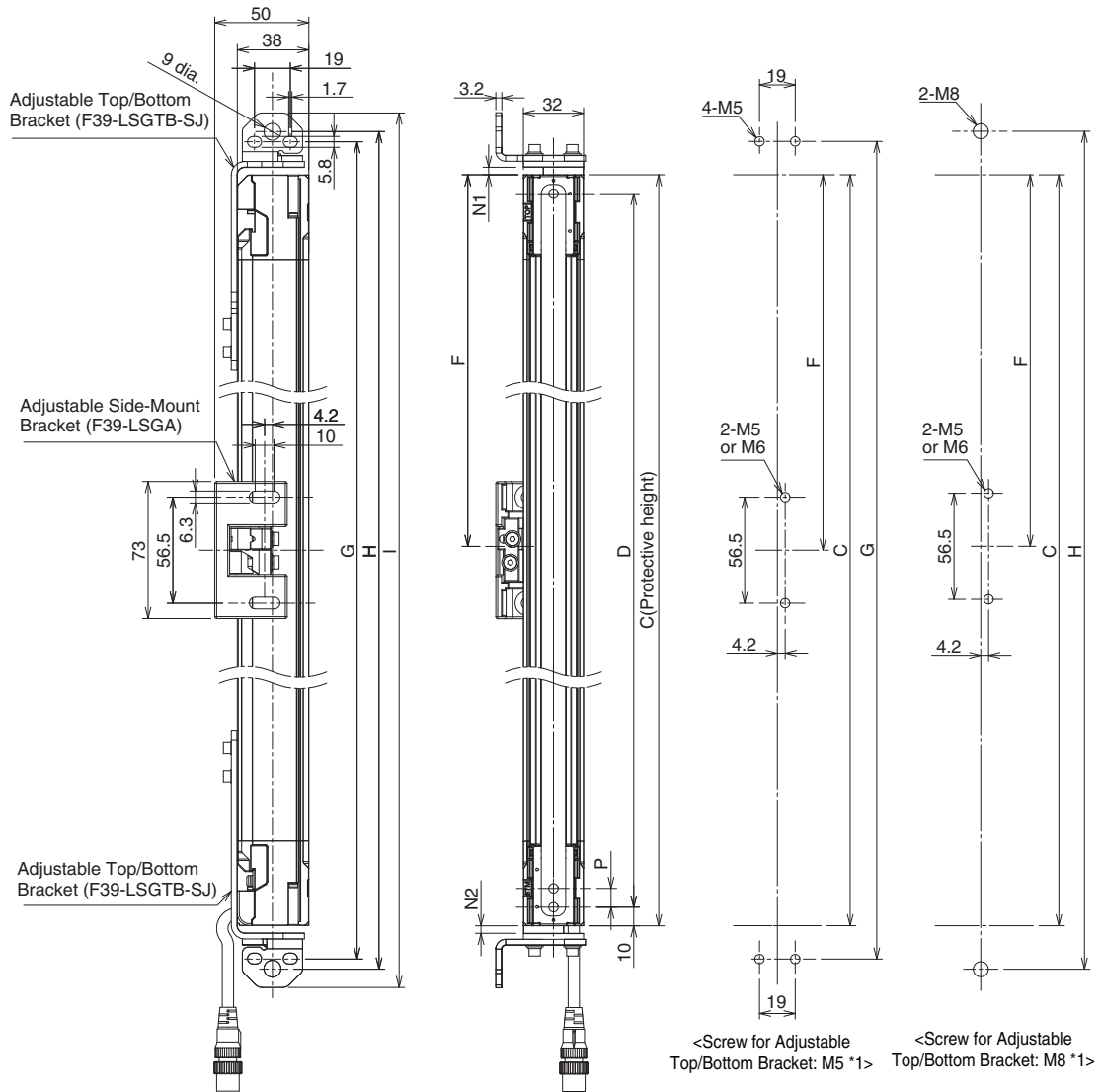

Dimension C	4-digit number of the type name (Protective height: Δ)	
Dimension D	F3SG-□SR□△△△△-14	C-20
	F3SG-□SR□△△△△-25	C-40
	F3SG-□SR□△△△△-45	
	F3SG-□SR□△△△△-85	
Dimension G	C+27.2+N1+N2	
Dimension H	C+38+N1+N2	
Dimension I	C+58+N1+N2	
Dimension N1	0 to 30 *2	
Dimension N2	0 to 30 *2	
Dimension P	F3SG-□SR□△△△△-14	10
	F3SG-□SR□△△△△-25	20
	F3SG-□SR□△△△△-45	40
	F3SG-□SR□△△△△-85	80



[Unit : mm]

Protective height (Dimension C)	Number of Adjustable Top/Bottom Bracket *3	Number of Intermediate Bracket *3	Dimension F
0160 to 0840	2	0	-
0880 to 1680	2	1	1000 mm max.
1760 to 2480	2	2	1000 mm max.

*1. Adjustable Side-Mount Bracket: M5 or M6

*2. For the model of protective height of 0160, the numbers corresponding to dimensions N1 and N2 are 26 to 30.

*3. The number of brackets required to mount either one of emitter and receiver.

5-3-4-4. Mounting with Adjustable Top/Bottom Brackets (F3SJ, F3SN Adapter) (F39-LSGTB-SJ) and Adjustable Side-Mount Brackets (Intermediate Brackets) (F39-LSGA)



- Use the brackets of specified quantities and locations according to the dimensions. The other brackets than described above may not meet the specified ratings and performance.
- When you use the sensor in a situation where the sensor is under a load, increase the number of the brackets used.
- The Adjustable Top/Bottom Bracket and Adjustable Side-Mount Bracket allow beam alignment after fixing the bracket to a wall surface. The angle adjustment range of the Adjustable Top/Bottom Brackets is ±22.5°. The angle adjustment range of the Adjustable Side-Mount Brackets is ±15°.

5-2-2. F3SG-PG Series

5-2-2-1. Mounted with Side-Mount Brackets (Intermediate Brackets) (F39-LSGF)

■ Backside Mounting

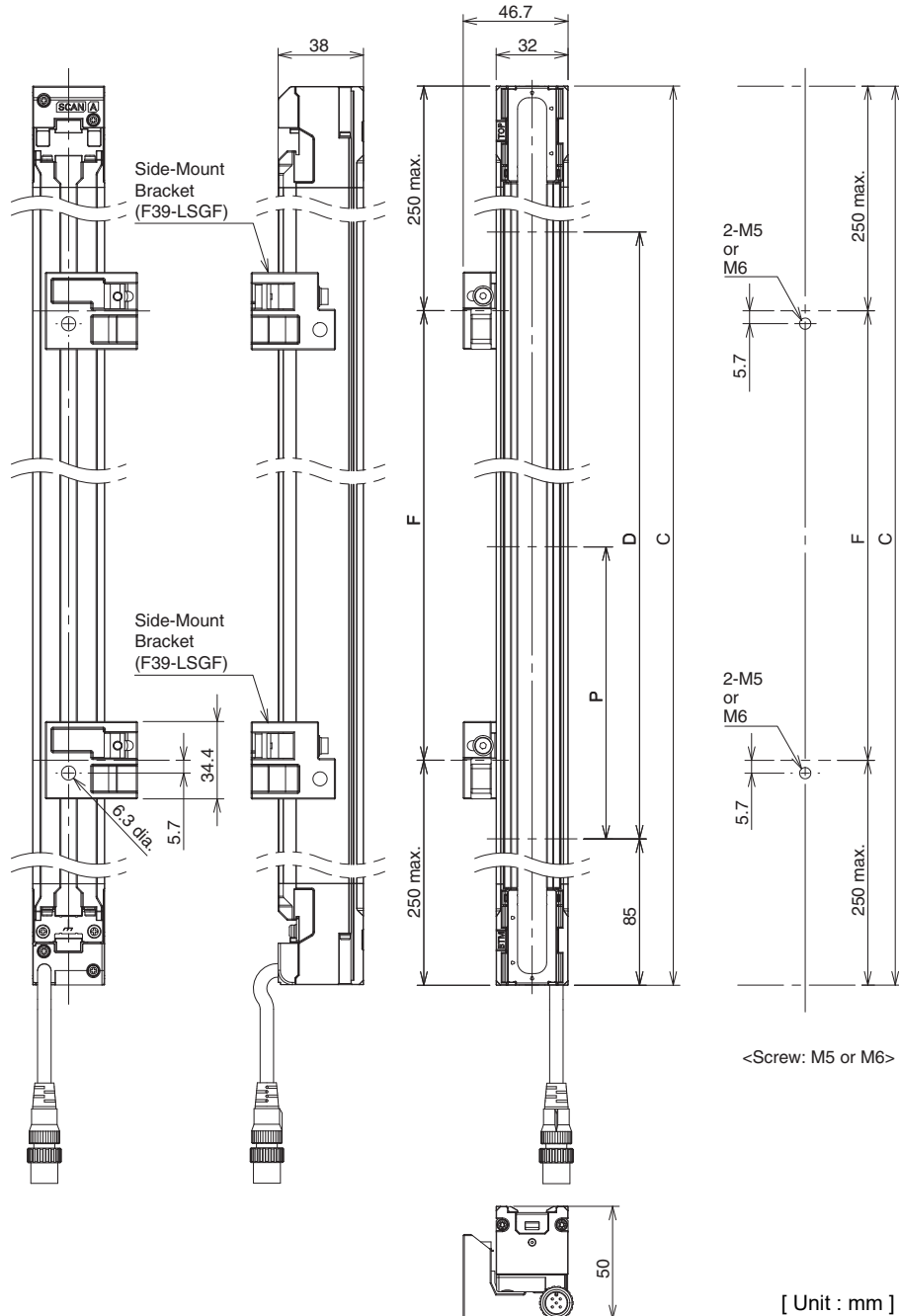



Dimension C	4-digit number of the type name (Protective height: △)	
Dimension D	C-170	
Dimension P	F3SG-4PGA0670-2□	500
	F3SG-4PGA0970-3□	400
	F3SG-4PGA1070-4□	300
	F3SG-4PGA1370-4□	400

Dimension C	Number of Side-Mount Bracket *	Dimension F
0670 to 1370	2	1000mm max.

* The number of brackets required to mount either one side of the sensor (emitter, receiver, emitter/receiver, or passive mirror)

5-3-4-1. Mounting with Side-Mount Brackets (Intermediate Brackets) (F39-LSGF)

- 
 - Use the brackets of specified quantities and locations according to the dimensions. The other brackets than described above may not meet the specified ratings and performance.
 - 
 - When you use the sensor in a situation where the sensor is under a load, increase the number of the brackets used.
- CHECK!** - Beam alignment cannot be performed with Side-Mount Brackets.

■ Side Mounting

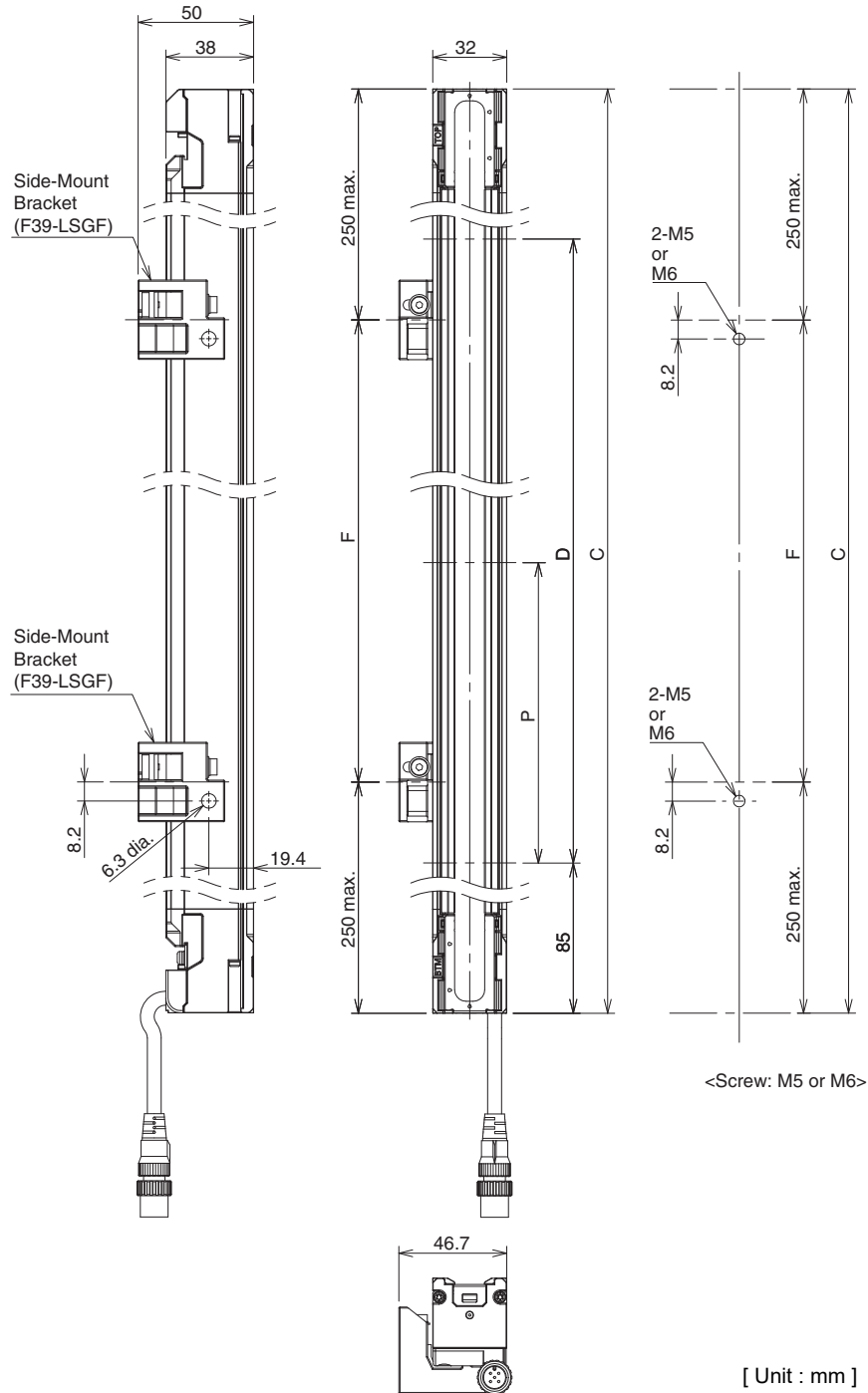

Dimension C	4-digit number of the type name (Protective height: △)	
Dimension D	C-170	
Dimension P	F3SG-4PGA0670-2□	500
	F3SG-4PGA0970-3□	400
	F3SG-4PGA1070-4□	300
	F3SG-4PGA1370-4□	400

Dimension C	Number of Side-Mount Bracket *	Dimension F
0670 to 1370	2	1000mm max.

* The number of brackets required to mount either one side of the sensor (emitter, receiver, emitter/receiver, or passive mirror)

5-3-4-1. Mounting with Side-Mount Brackets (Intermediate Brackets) (F39-LSGF)

- Use the brackets of specified quantities and locations according to the dimensions. The other brackets than described above may not meet the specified ratings and performance.
 - When you use the sensor in a situation where the sensor is under a load, increase the number of the brackets used.
- CHECK!** - Beam alignment cannot be performed with Side-Mount Brackets.

5-2-2-2. Mounted with Adjustable Side-Mount Brackets (Intermediate Brackets) (F39-LSGA)

■ Backside Mounting

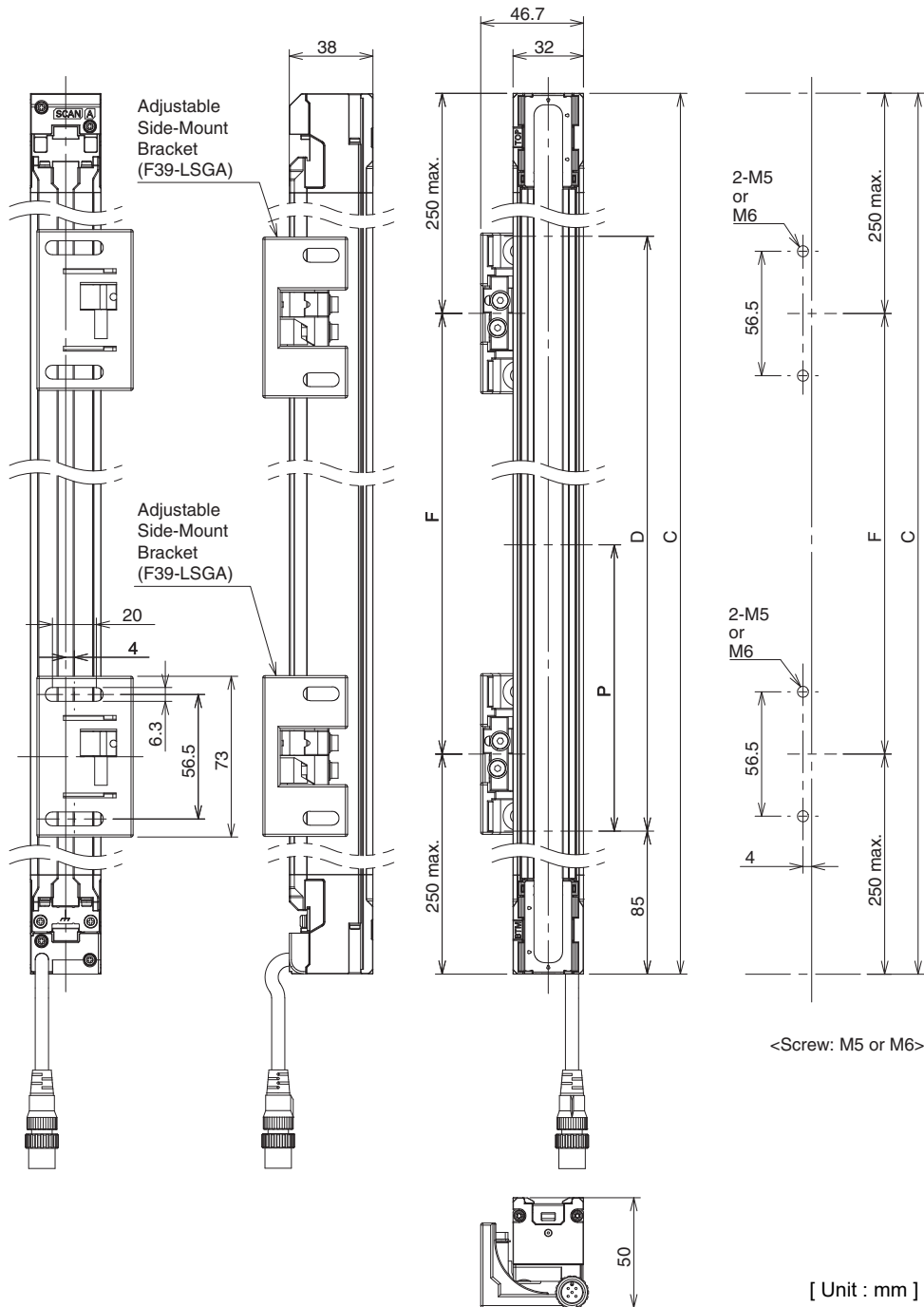

Dimension C	4-digit number of the type name (Protective height: △)	
Dimension D	C-170	
Dimension P	F3SG-4PGA0670-2□	500
	F3SG-4PGA0970-3□	400
	F3SG-4PGA1070-4□	300
	F3SG-4PGA1370-4□	400

Dimension C	Number of Adjustable Side-Mount Bracket *	Dimension F
0670 to 1370	2	1000mm max.

* The number of brackets required to mount either one side of the sensor (emitter, receiver, emitter/receiver, or passive mirror)

5-3-4-2. Mounting with Adjustable Side-Mount Brackets (Intermediate Brackets) (F39-LSGA)

- Use the brackets of specified quantities and locations according to the dimensions. The other brackets than described above may not meet the specified ratings and performance.
- When you use the sensor in a situation where the sensor is under a load, increase the number of the brackets used.
- CHECK!** - The Adjustable Side-Mount Bracket allows beam alignment after fixing the bracket to a wall surface. The angle adjustment range of the Adjustable Side-Mount Brackets is $\pm 15^\circ$.

■ Side Mounting

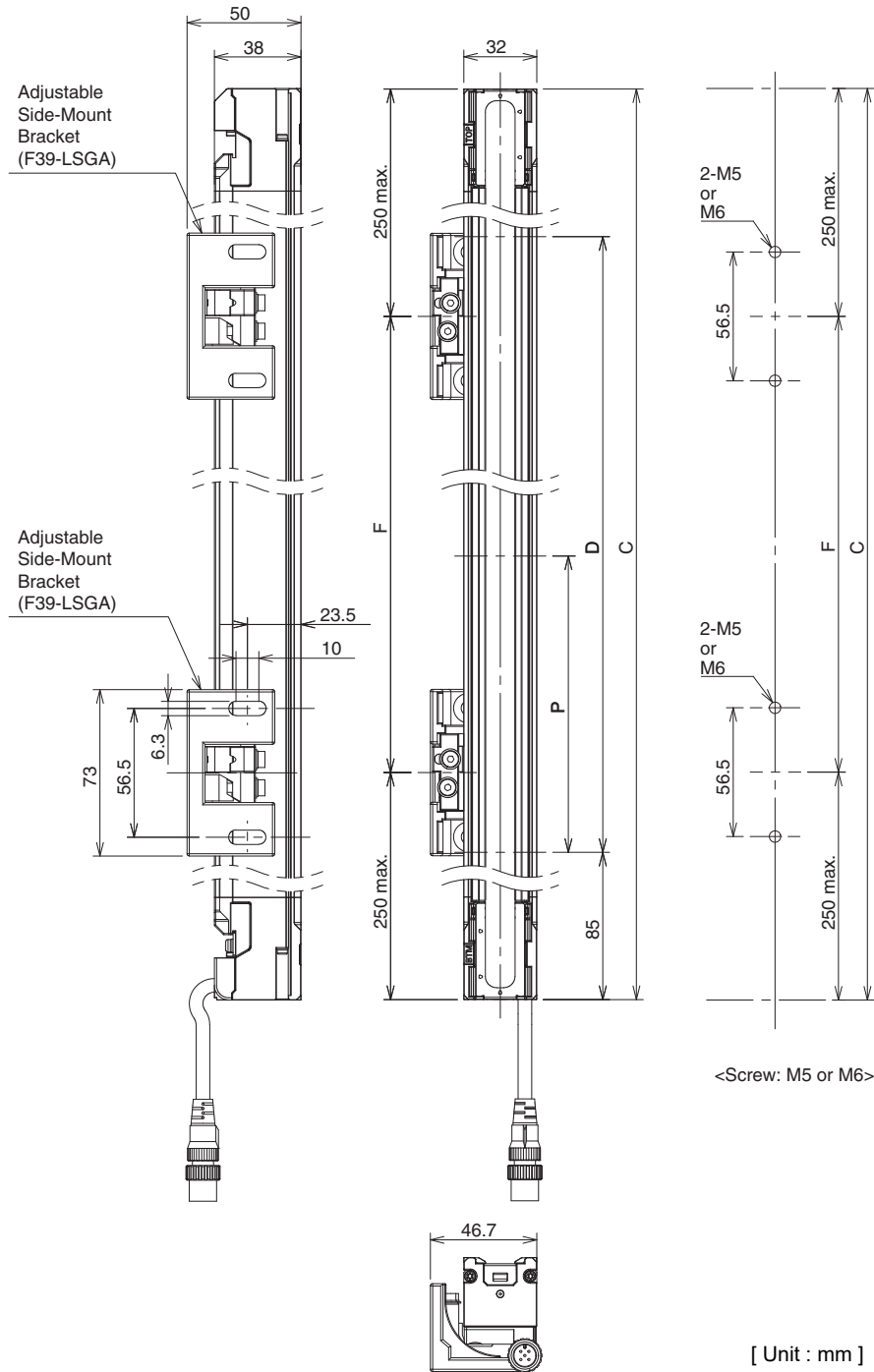

Dimension C	4-digit number of the type name (Protective height: △)	
Dimension D	C-170	
Dimension P	F3SG-4PGA0670-2□	500
	F3SG-4PGA0970-3□	400
	F3SG-4PGA1070-4□	300
	F3SG-4PGA1370-4□	400

Dimension C	Number of Adjustable Side-Mount Bracket *	Dimension F
0670 to 1370	2	1000mm max.

* The number of brackets required to mount either one side of the sensor (emitter, receiver, emitter/receiver, or passive mirror)

5-3-4-2. Mounting with Adjustable Side-Mount Brackets (Intermediate Brackets) (F39-LSGA)

- Use the brackets of specified quantities and locations according to the dimensions. The other brackets than described above may not meet the specified ratings and performance.
 - When you use the sensor in a situation where the sensor is under a load, increase the number of the brackets used.
- CHECK!** - The Adjustable Side-Mount Bracket allows beam alignment after fixing the bracket to a wall surface. The angle adjustment range of the Adjustable Side-Mount Brackets is $\pm 15^\circ$.

5-2-2-3. Mounted with Adjustable Top/Bottom Brackets (F3SJ, F3SN Adapter) (F39-LSGTB-SJ) and Side-Mount Bracket (Intermediate Bracket) (F39-LSGF)

■ Backside Mounting

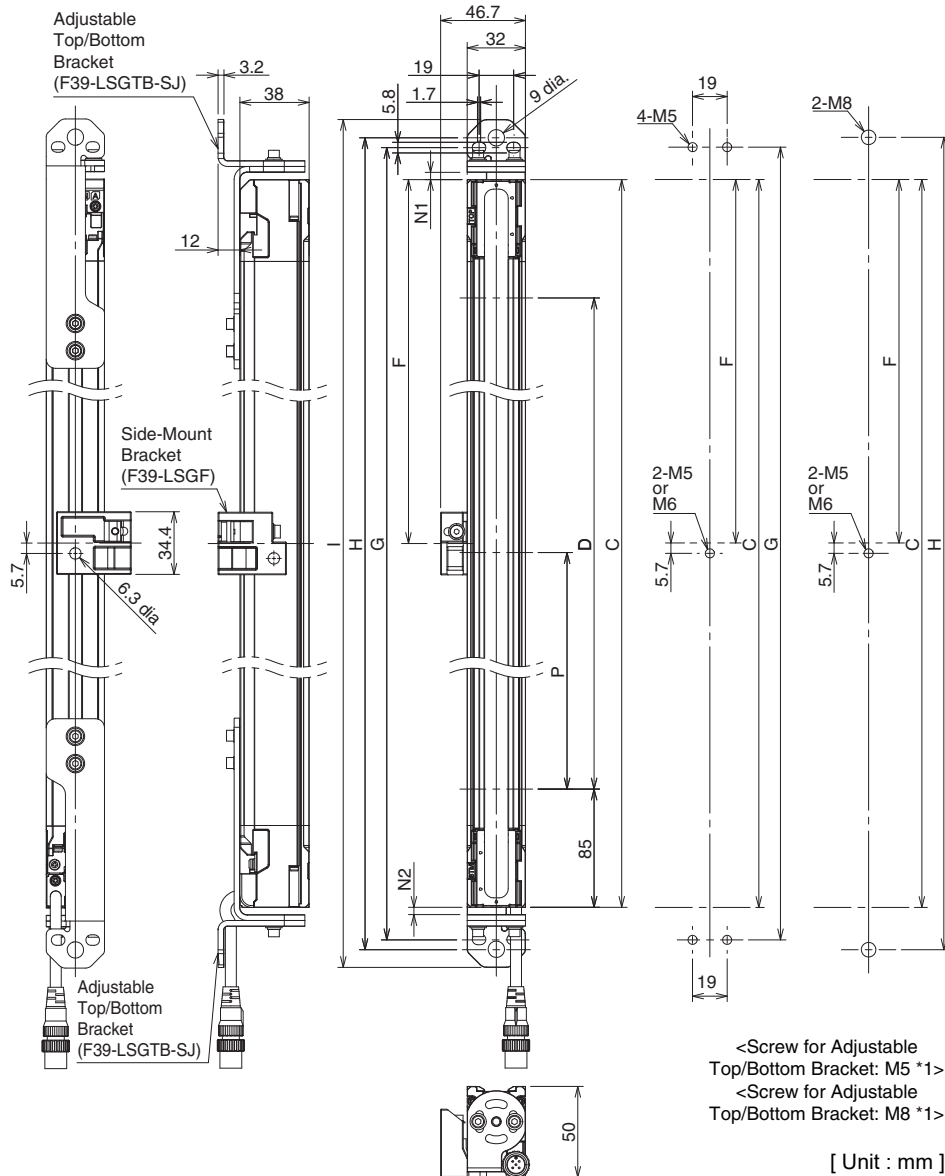

Dimension C	4-digit number of the type name (Protective height: △)	
Dimension D	C-170	
Dimension G	C+27.2+N1+N2	
Dimension H	C+38+N1+N2	
Dimension I	C+58+N1+N2	
Dimension N1	0 to 30	
Dimension N2	0 to 30	
Dimension P	F3SG-4PGA0670-2□	500
	F3SG-4PGA0970-3□	400
	F3SG-4PGA1070-4□	300
	F3SG-4PGA1370-4□	400

Dimension C	Number of Adjustable Top/Bottom Bracket *2	Number of Intermediate Bracket *2	Dimension F
0670	2	0	-
0970 to 1370		1	1000mm max.

*1. Side-Mount Bracket: M5 or M6

*2. The number of brackets required to mount either one side of the sensor (emitter, receiver, emitter/receiver, or passive mirror)

5-3-4-3. Mounting with Adjustable Top/Bottom Brackets (F3SJ, F3SN Adapter) (F39-LSGTB-SJ) and Side-Mount Brackets (Intermediate Brackets) (F39-LSGF)

- Use the brackets of specified quantities and locations according to the dimensions. The other brackets than described above may not meet the specified ratings and performance.
- When you use the sensor in a situation where the sensor is under a load, increase the number of the brackets used.
- CHECK!** - Beam alignment cannot be performed in combination with Adjustable Top/Bottom Brackets and Side-Mount Brackets with the Brackets fixed to the wall surface.

■ Side Mounting

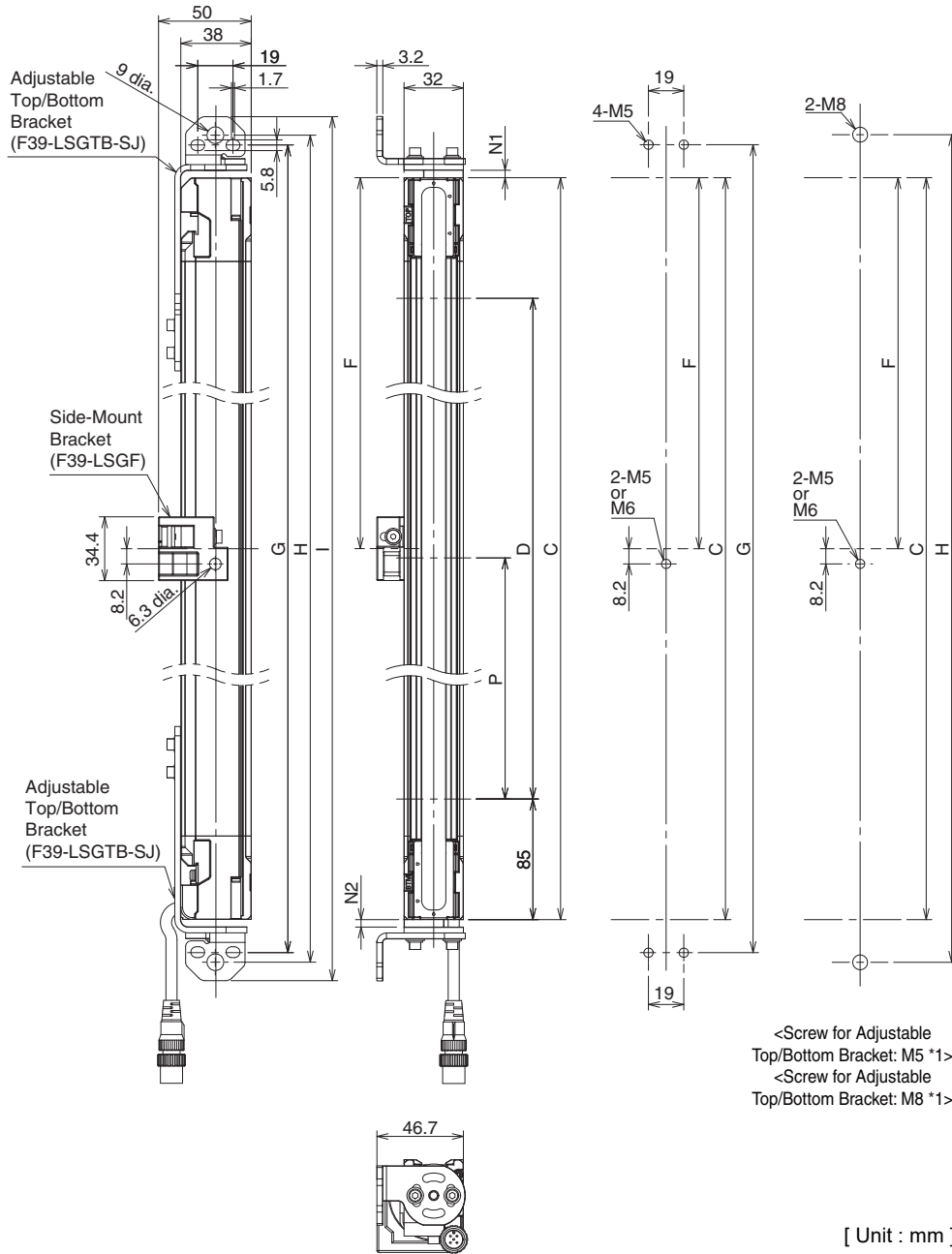

[Unit : mm]

Dimension C	4-digit number of the type name (Protective height: Δ)	
Dimension D	C-170	
Dimension G	C+27.2+N1+N2	
Dimension H	C+38+N1+N2	
Dimension I	C+58+N1+N2	
Dimension N1	0 to 30	
Dimension N2	0 to 30	
Dimension P	F3SG-4PGA0670-2□	500
	F3SG-4PGA0970-3□	400
	F3SG-4PGA1070-4□	300
	F3SG-4PGA1370-4□	400

Dimension C	Number of Adjustable Top/Bottom Bracket *2	Number of Intermediate Bracket *2	Dimension F
0670	2	0	-
0970 to 1370		1	1000mm max.

*1. Side-Mount Bracket: M5 or M6

*2. The number of brackets required to mount either one side of the sensor (emitter, receiver, emitter/receiver, or passive mirror)

5-3-4-3. Mounting with Adjustable Top/Bottom Brackets (F3SJ, F3SN Adapter) (F39-LSGTB-SJ) and Side-Mount Brackets (Intermediate Brackets) (F39-LSGF)

- Use the brackets of specified quantities and locations according to the dimensions. The other brackets than described above may not meet the specified ratings and performance.

- When you use the sensor in a situation where the sensor is under a load, increase the number of the brackets used.

CHECK! - Beam alignment cannot be performed in combination with Adjustable Top/Bottom Brackets and Side-Mount Brackets with the Brackets fixed to the wall surface.

5-2-2-4. Mounted with Adjustable Top/Bottom Brackets (F3SJ, F3SN Adapter) (F39-LSGTB-SJ) and Adjustable Side-Mount Bracket (Intermediate Bracket) (F39-LSGA)

■ Backside Mounting

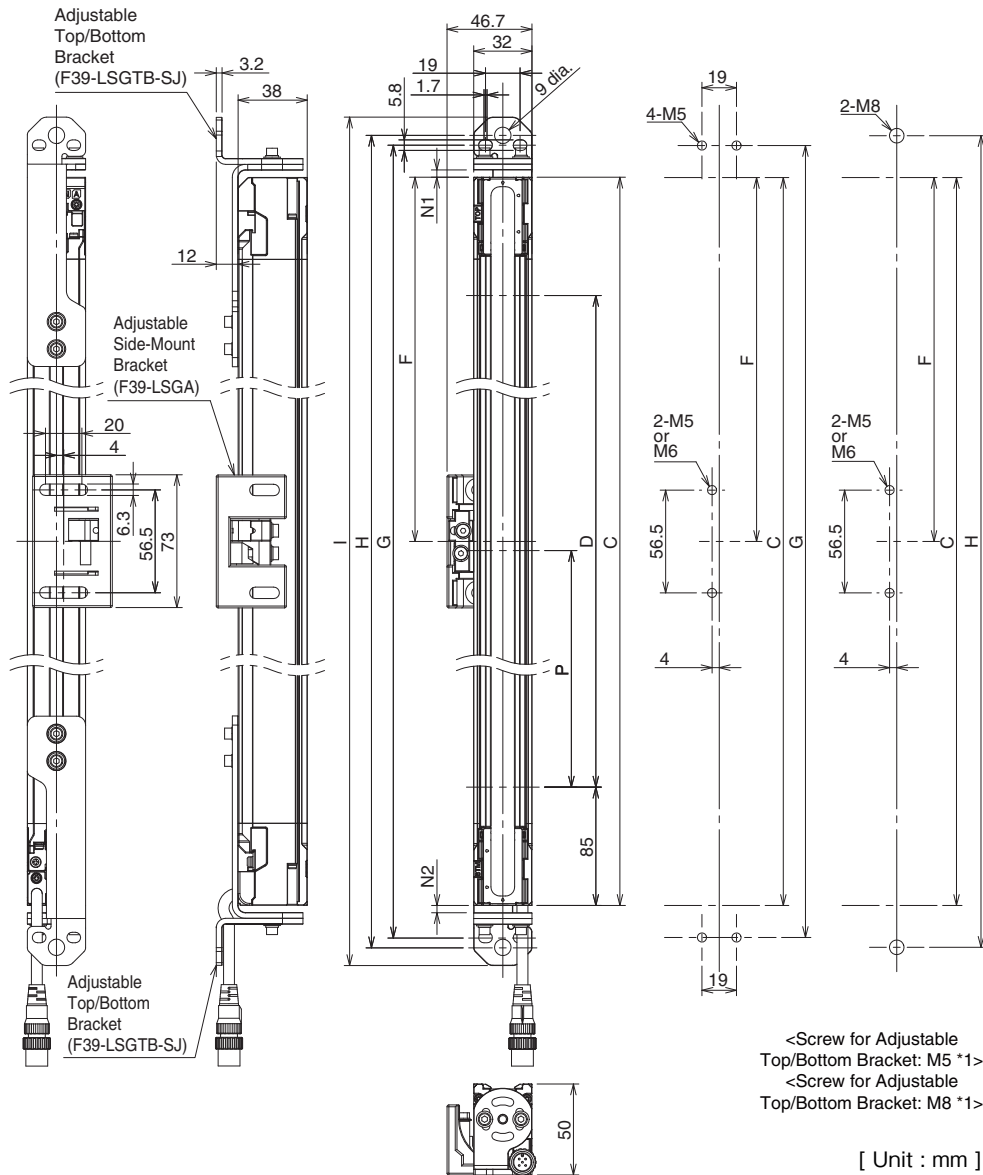

Dimension C	4-digit number of the type name (Protective height: △)	
Dimension D	C-170	
Dimension G	C+27.2+N1+N2	
Dimension H	C+38+N1+N2	
Dimension I	C+58+N1+N2	
Dimension N1	0 to 30	
Dimension N2	0 to 30	
Dimension P	F3SG-4PGA0670-2□	500
	F3SG-4PGA0970-3□	400
	F3SG-4PGA1070-4□	300
	F3SG-4PGA1370-4□	400

Dimension C	Number of Adjustable Top/Bottom Bracket *2	Number of Intermediate Bracket *2	Dimension F
0670	2	0	-
0970 to 1370		1	1000mm max.

*1. Side-Mount Bracket: M5 or M6

*2. The number of brackets required to mount either one side of the sensor (emitter, receiver, emitter/receiver, or passive mirror)

5-3-4-4. Mounting with Adjustable Top/Bottom Brackets (F3SJ, F3SN Adapter) (F39-LSGTB-SJ) and Adjustable Side-Mount Brackets (Intermediate Brackets) (F39-LSGA)

- Use the brackets of specified quantities and locations according to the dimensions. The other brackets than described above may not meet the specified ratings and performance.
- When you use the sensor in a situation where the sensor is under a load, increase the number of the brackets used.
- CHECK!** - The Adjustable Top/Bottom Bracket and Adjustable Side-Mount Bracket allow beam alignment after fixing the bracket to a wall surface. The angle adjustment range of the Adjustable Top/Bottom Brackets is $\pm 22.5^\circ$. The angle adjustment range of the Adjustable Side-Mount Brackets is $\pm 15^\circ$.

■ Side Mounting

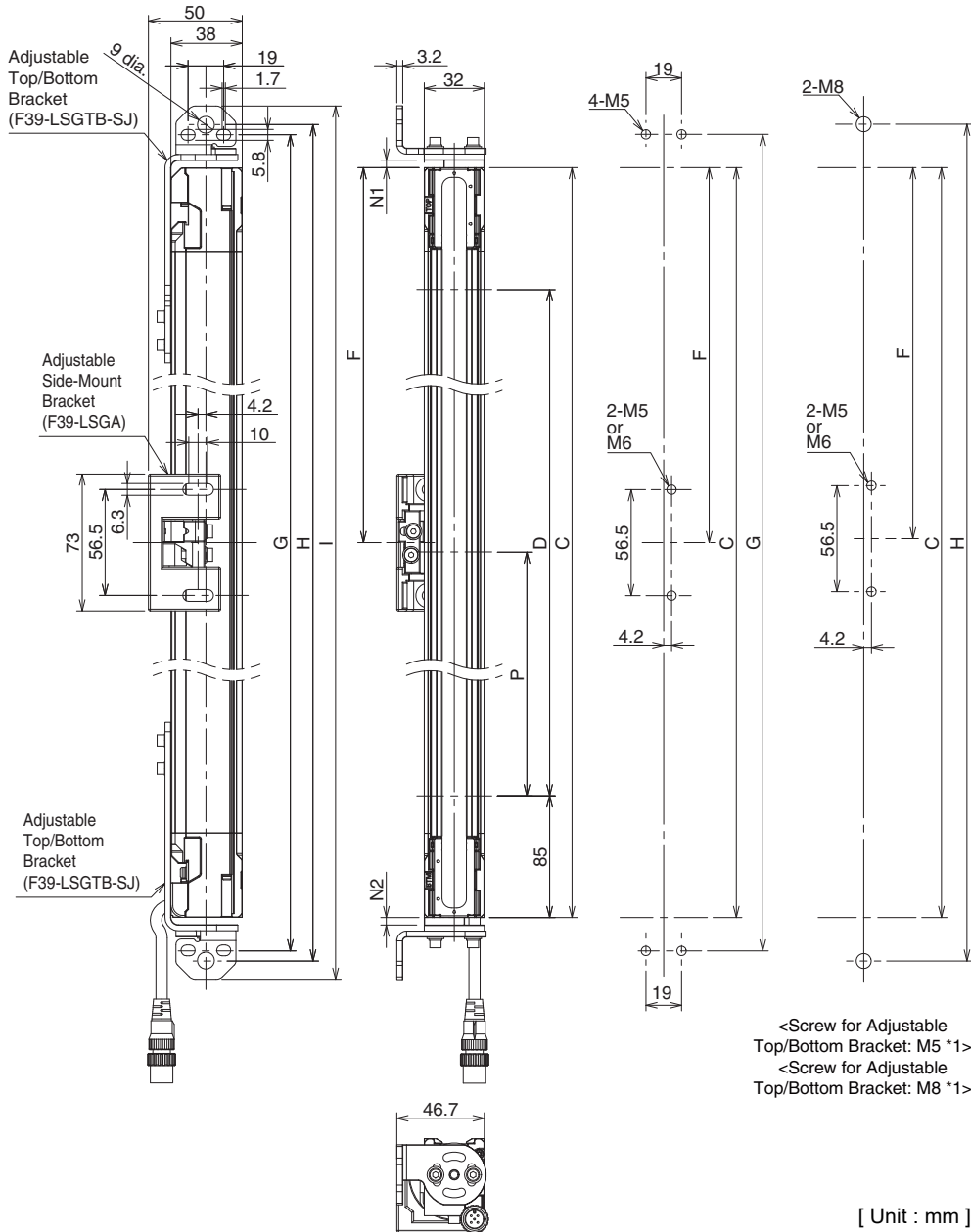

[Unit : mm]

Dimension C	4-digit number of the type name (Protective height: △)	
Dimension D	C-170	
Dimension G	C+27.2+N1+N2	
Dimension H	C+38+N1+N2	
Dimension I	C+58+N1+N2	
Dimension N1	0 to 30	
Dimension N2	0 to 30	
Dimension P	F3SG-4PGA0670-2□	500
	F3SG-4PGA0970-3□	400
	F3SG-4PGA1070-4□	300
	F3SG-4PGA1370-4□	400

Dimension C	Number of Adjustable Top/Bottom Bracket *2	Number of Intermediate Bracket *2	Dimension F
0670	2	0	-
0970 to 1370		1	1000mm max.

*1. Side-Mount Bracket: M5 or M6

*2. The number of brackets required to mount either one side of the sensor (emitter, receiver, emitter/receiver, or passive mirror)

5-3-4-4. Mounting with Adjustable Top/Bottom Brackets (F3SJ, F3SN Adapter) (F39-LSGTB-SJ) and Adjustable Side-Mount Brackets (Intermediate Brackets) (F39-LSGA)

- Use the brackets of specified quantities and locations according to the dimensions. The other brackets than described above may not meet the specified ratings and performance.
- When you use the sensor in a situation where the sensor is under a load, increase the number of the brackets used.
- CHECK!** - The Adjustable Top/Bottom Bracket and Adjustable Side-Mount Bracket allow beam alignment after fixing the bracket to a wall surface. The angle adjustment range of the Adjustable Top/Bottom Brackets is $\pm 22.5^\circ$. The angle adjustment range of the Adjustable Side-Mount Brackets is $\pm 15^\circ$.

5-2-3. Bracket

5-2-3-1. Side-Mount Bracket (Intermediate Bracket) (F39-LSGF sold, separately)

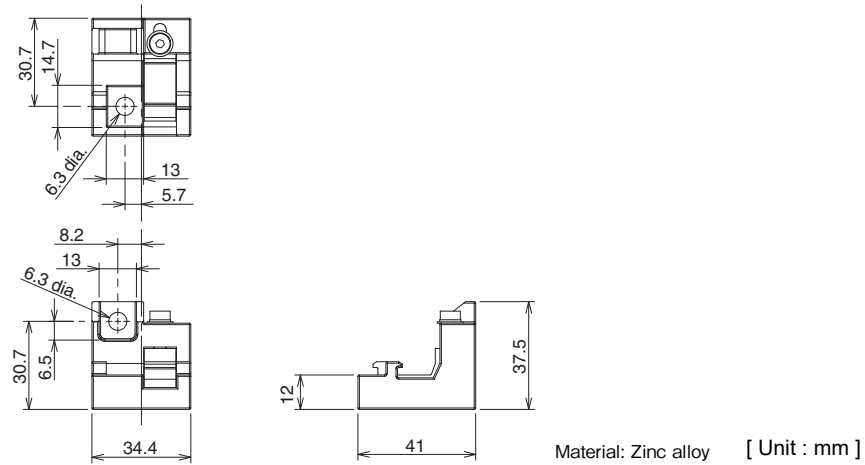

5-2-3-2. Adjustable Side-Mount Bracket (Intermediate Bracket) (F39-LSGA, sold separately)

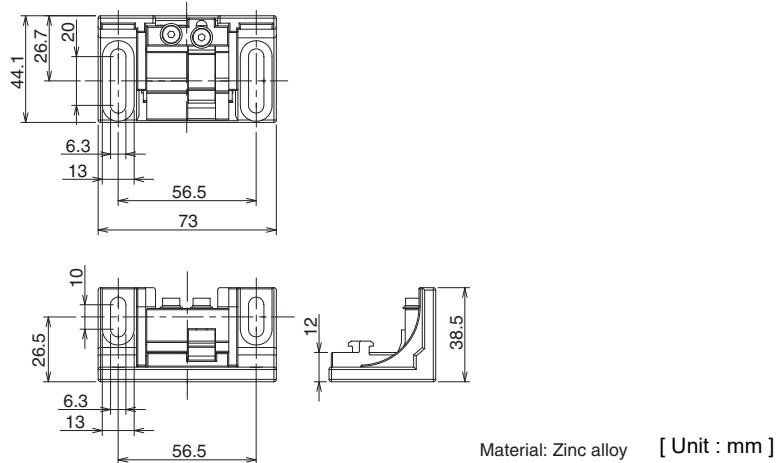

5-2-3-3. Adjustable Top/Bottom Bracket (F3SJ, F3SN Adapter) (F39-LSGTB-SJ, sold separately)

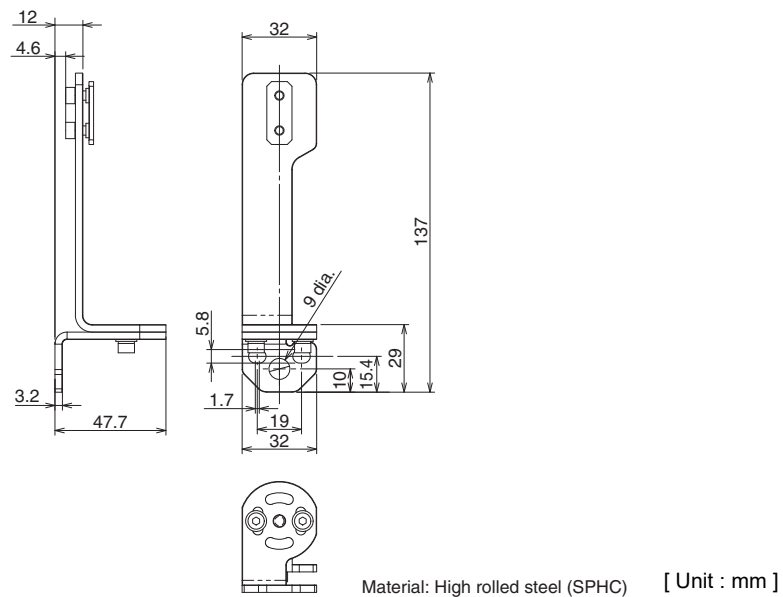

5-2-3-4. Adjustable Top/Bottom Bracket (F3SG-RA/RE Adapter) (F39-LSGTB-RE, sold separately)

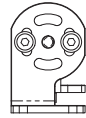
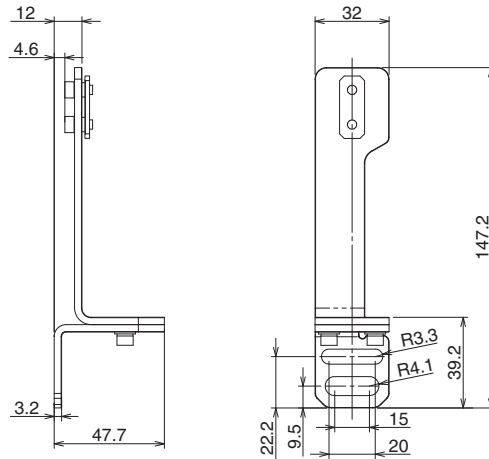

Material: High rolled steel (SPHC) [Unit : mm]

5-2-3-5. Adjustable Top/Bottom Bracket (MS4800, F3SR Adapter) (F39-LSGTB-MS, sold separately)

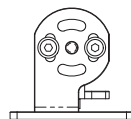
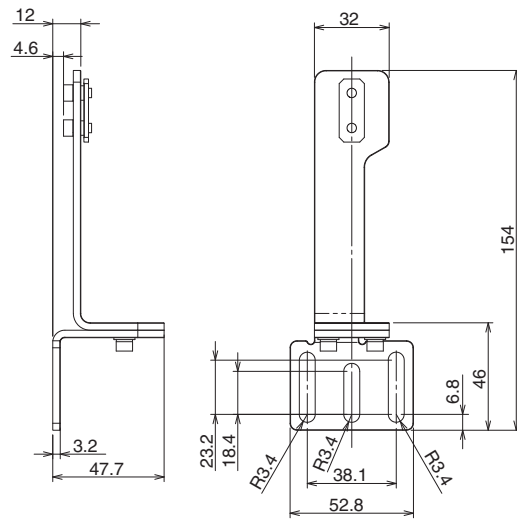

Material: High rolled steel (SPHC) [Unit : mm]

5-2-4. Intelligent Tap

- Intelligent Tap (F39-SGIT-IL3, sold separately)

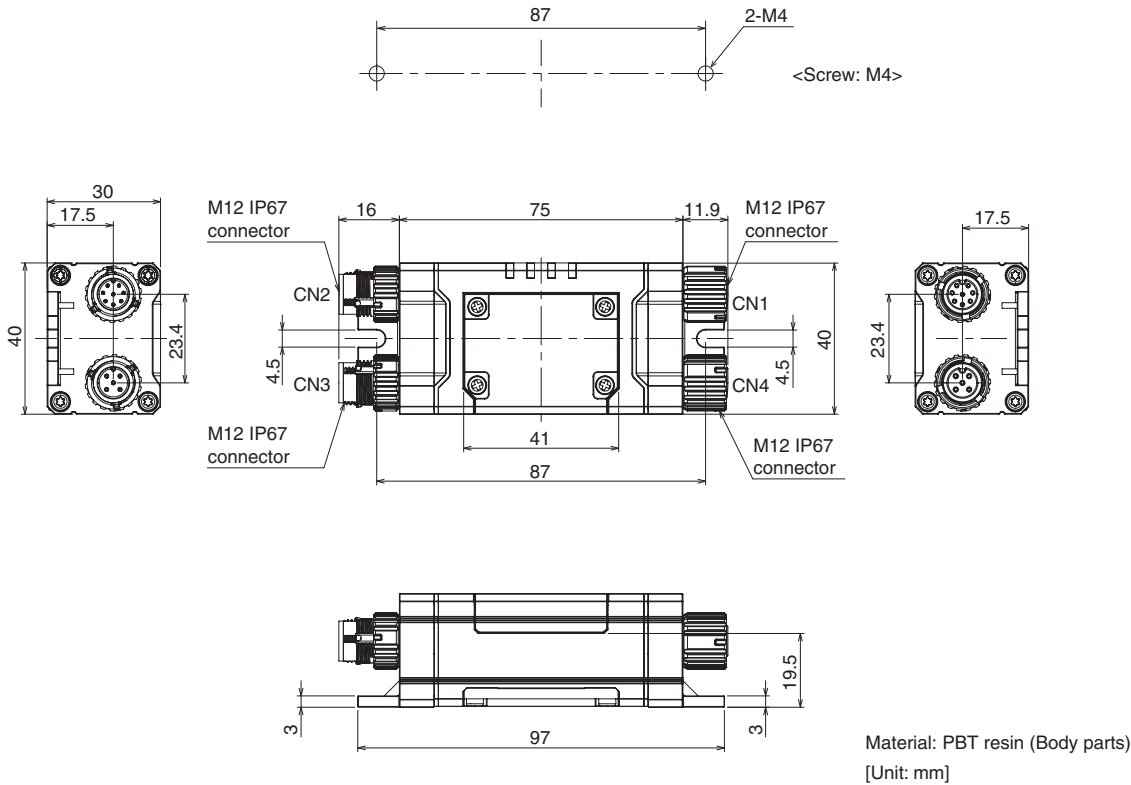

5-2-5. Intelligent Tap Bracket

- Intelligent Tap Bracket (F39- LITF1, sold separately)

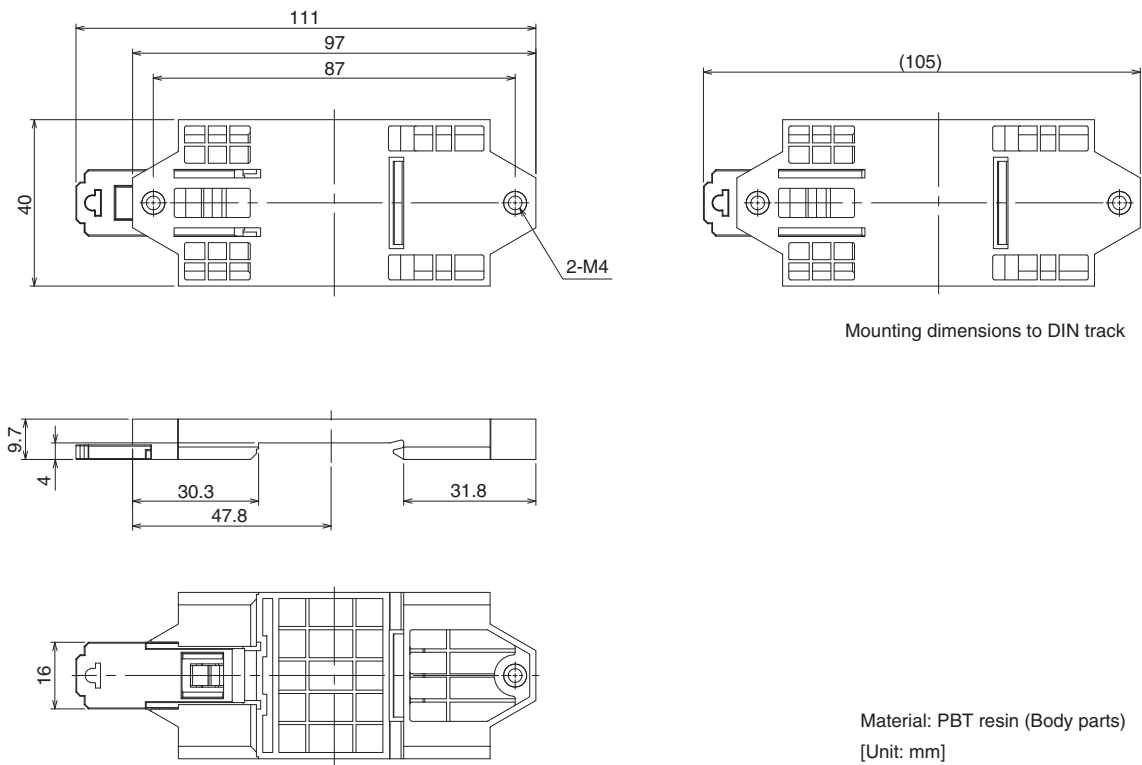

▪ Assembly Dimensions (Intelligent Tap/ Intelligent Tap Bracket)

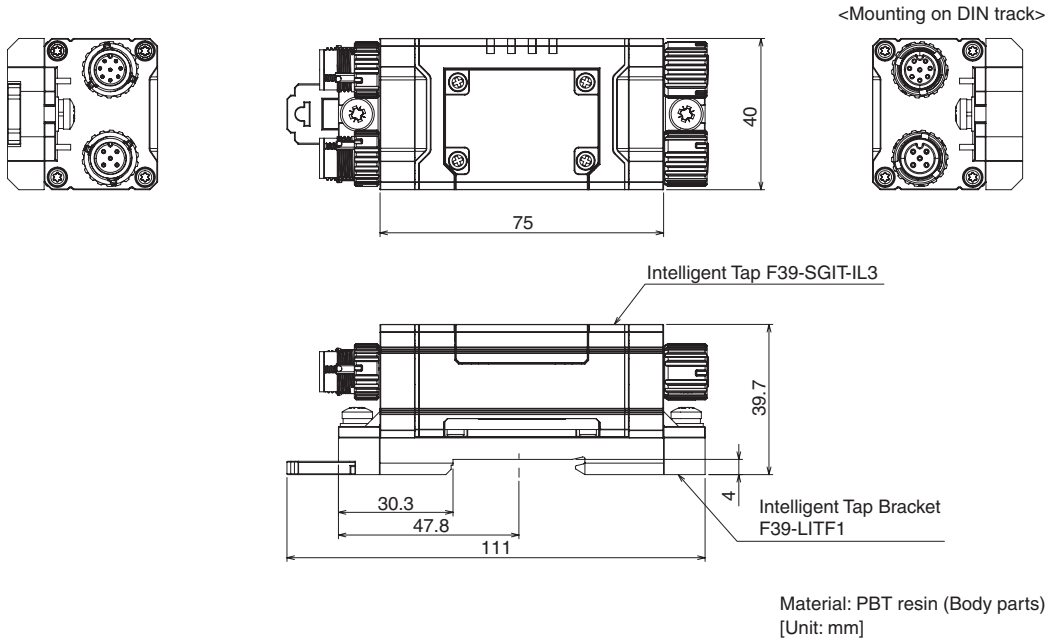

5-2-6. Bluetooth® Communication Unit

- Bluetooth® Communication Unit (F39-SGBT, sold separately)

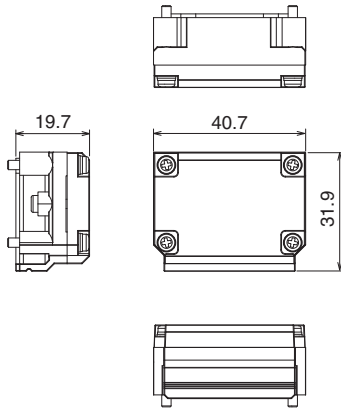

Material: PBT resin (Body parts)
[Unit: mm]

- Assembly Dimensions (Intelligent Tap/Bluetooth® Communication Unit/Intelligent Tap Bracket, sold separately)

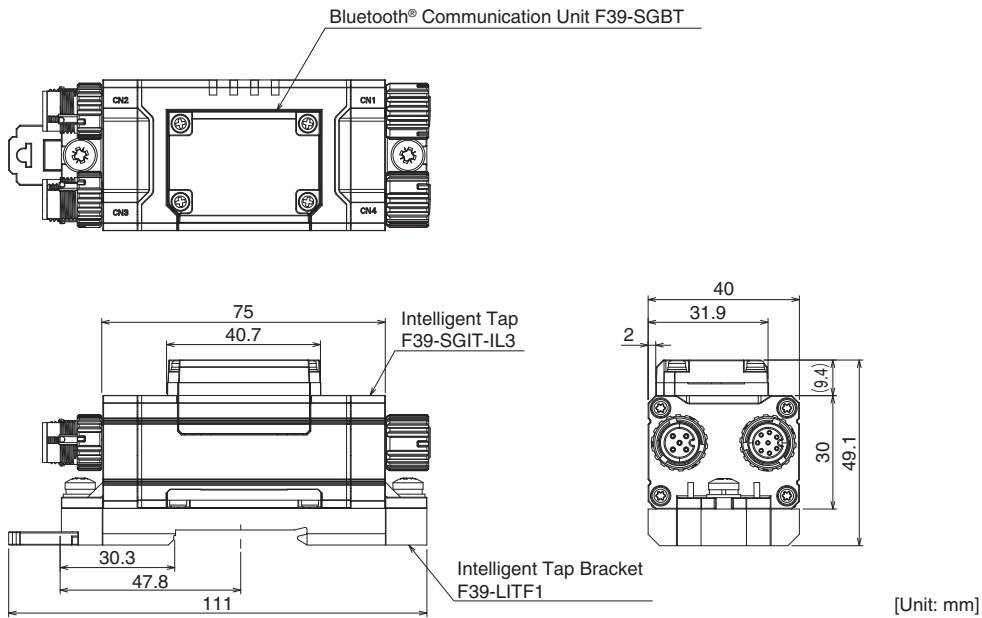

[Unit: mm]

5-2-7. Spatter Protection Cover

- Spatter Protection Cover (F39-HSG□□□□, sold separately)

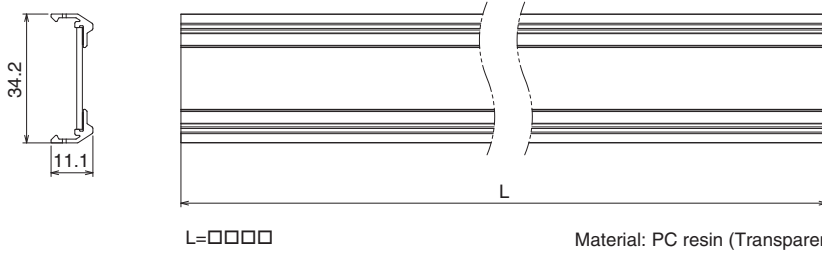

Material: PC resin (Transparent cover)
ABS resin (Side wall)
[Unit: mm]

- Assembly Dimensions

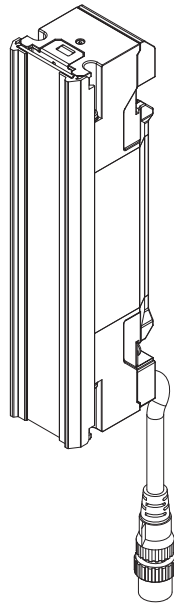
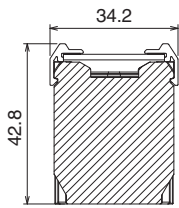

[Unit: mm]

5-2-8. Laser Alignment Pointer

- Laser Alignment Pointer (F39-PTS, sold separately)

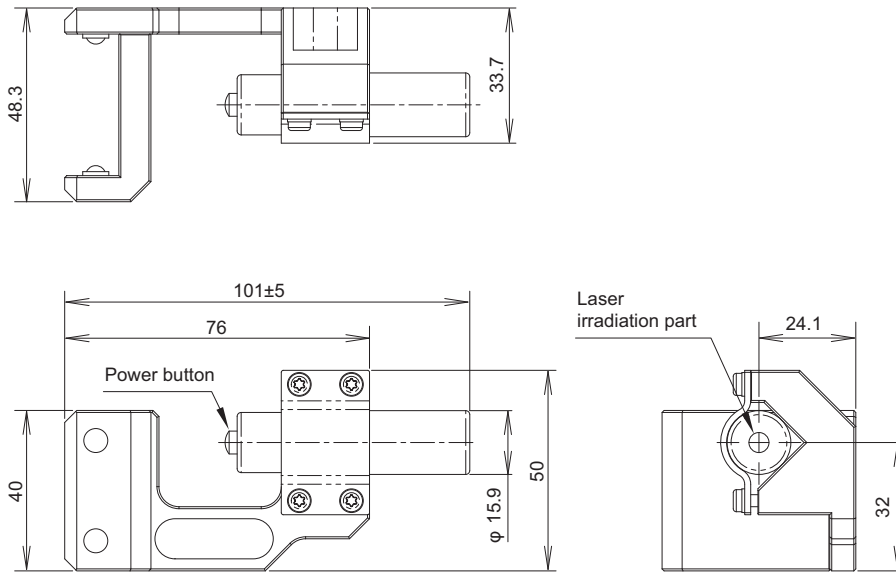

Material: Aluminum (Laser module case)
 Aluminum, stainless (Attaching part)
 [Unit: mm]

5-2-9. Lamps

- Lamp (F39-SGLP, sold separately)

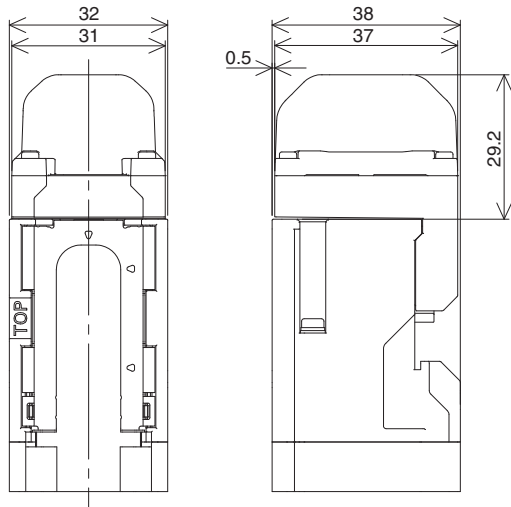

Material: PC resin (Transparent cover)
PBT resin (Base)
[Unit: mm]

- Assembly Dimensions

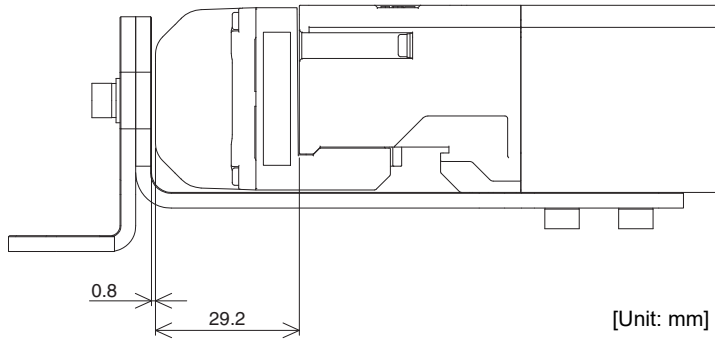

[Unit: mm]

5-2-10. Muting Sensor Arm Mounter

■ Muting Sensor Arm Mounter (F39-FMA□□□□, sold separately)

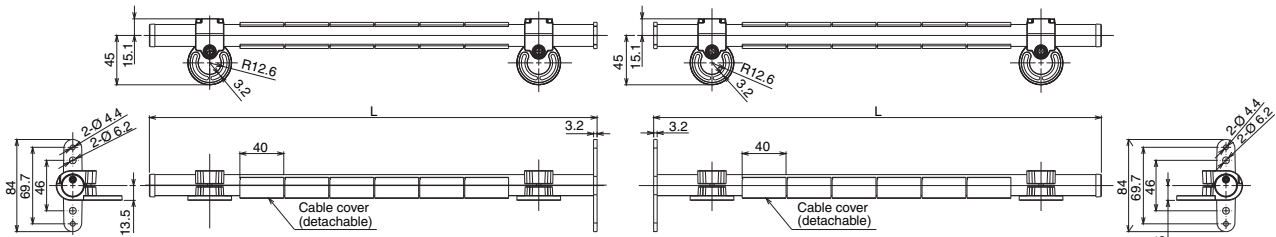

Model	Dimension L	Number of cable covers attached
F39-FMA150T	158.2	1
F39-FMA400T	408.2	6

Material: PBT resin
 (Sensor mounting bracket)
 PC resin (Cable cover)
 High rolled steel (Base)
 Aluminum alloy (Arm)
 [Unit: mm]

■ Muting Sensor Arm Mounter Bracket for SLC (F39-LMAF1, sold separately)

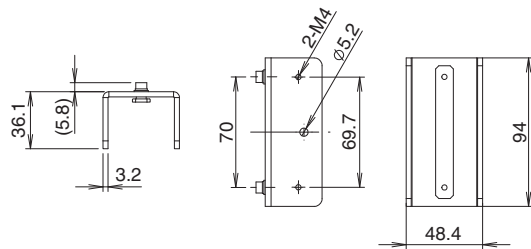

Material: High rolled steel
 [Unit: mm]

■ Assembly Dimensions

- Mounting F39-FMA□□□□-T on Muting Sensor Arm Mounter Bracket for SLC (F39-LMAF1)

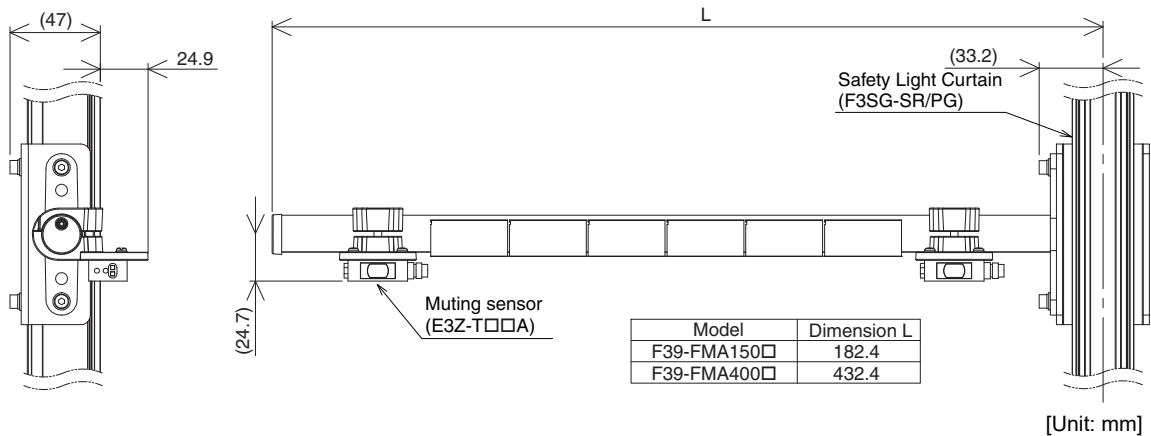

- Mounting F39-FMA□□□□-R on Floor Mounting Column (F39-ST□□□□)

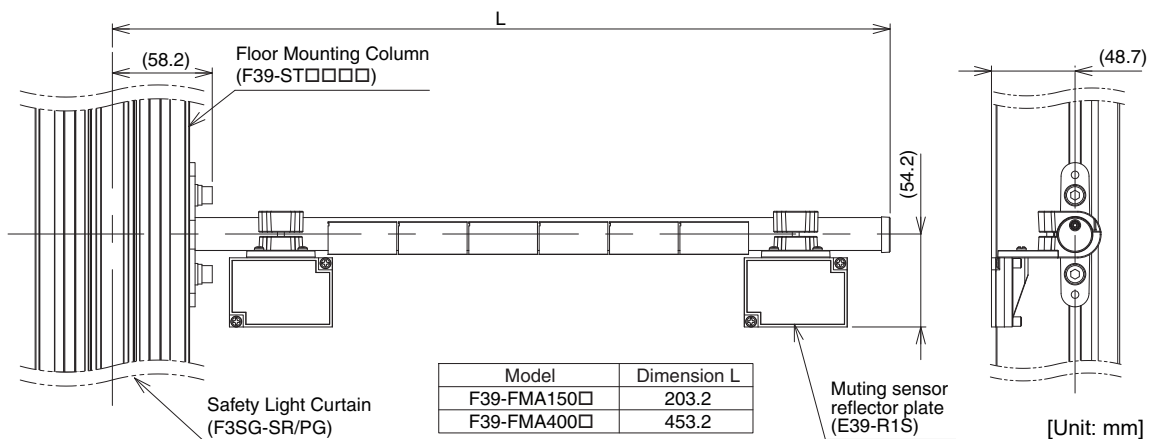

5-2-11. Floor Mounting Column

■ Floor Mounting Column (F39-ST□□□□, sold separately)

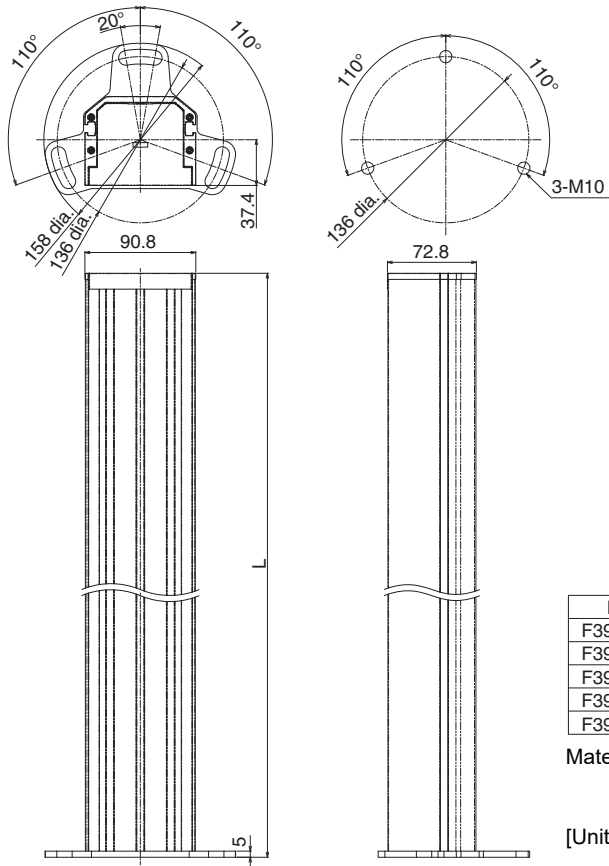

Model	Dimension L
F39-ST0990	990
F39-ST1310	1310
F39-ST1630	1630
F39-ST1950	1950
F39-ST2270	2270

Material: Aluminum alloy (Case)
 High rolled steel (Base)
 PBT resin (Cap)
 [Unit: mm]

■ Mount-Column Adjustable Base (F39-STB, sold separately)

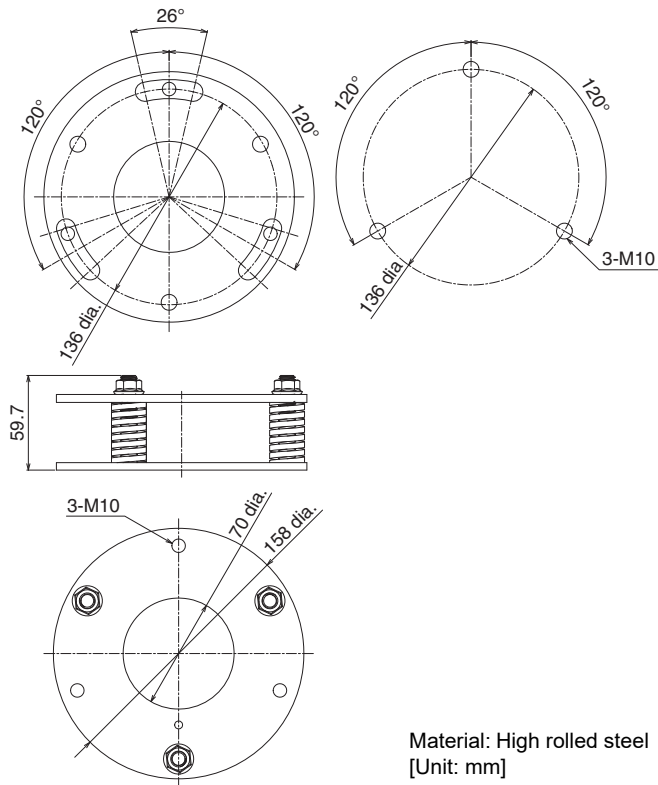

Material: High rolled steel
 [Unit: mm]

▪ Assembly Dimensions

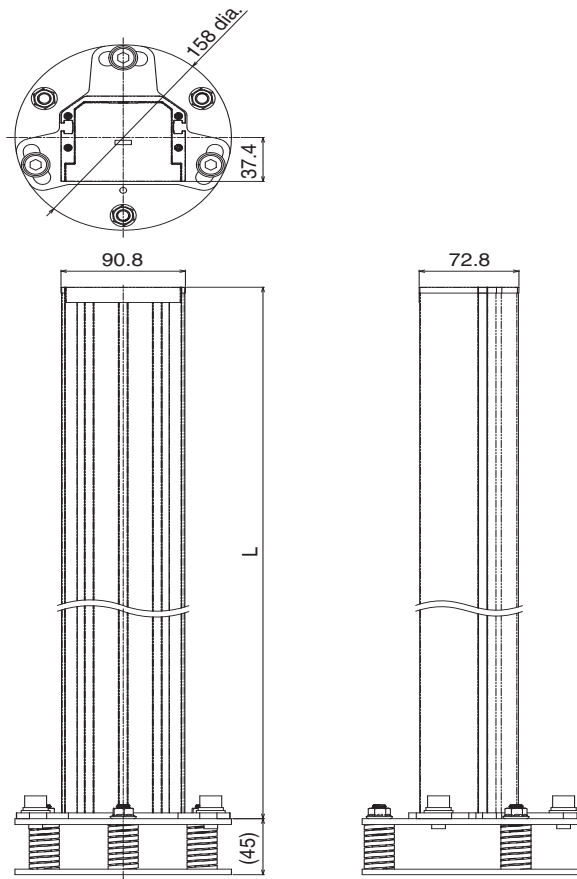

Model	Dimension L
F39-ST0990	990
F39-ST1310	1310
F39-ST1630	1630
F39-ST1950	1950
F39-ST2270	2270

[Unit: mm]

5-2-12. Mirror Columns

- Mirror Column (for Safety Light Curtain F3SG-SR and Safety Multi-Light Beam F3SG-PGA-A/L) (F39-SML-□□□□, sold separately)

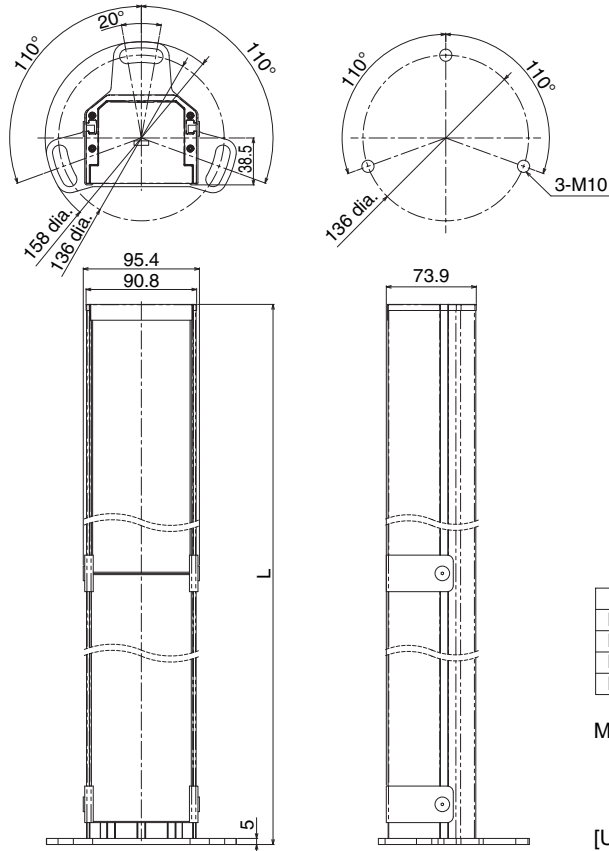

Model	Dimension L
F39-SML0990	990
F39-SML1310	1310
F39-SML1630	1630
F39-SML1950	1950

Material: Aluminum alloy (Case)
 High rolled steel (Base)
 PBT resin (Cap)
 Glass mirror (Mirror)
 [Unit: mm]

- Assembly Dimensions

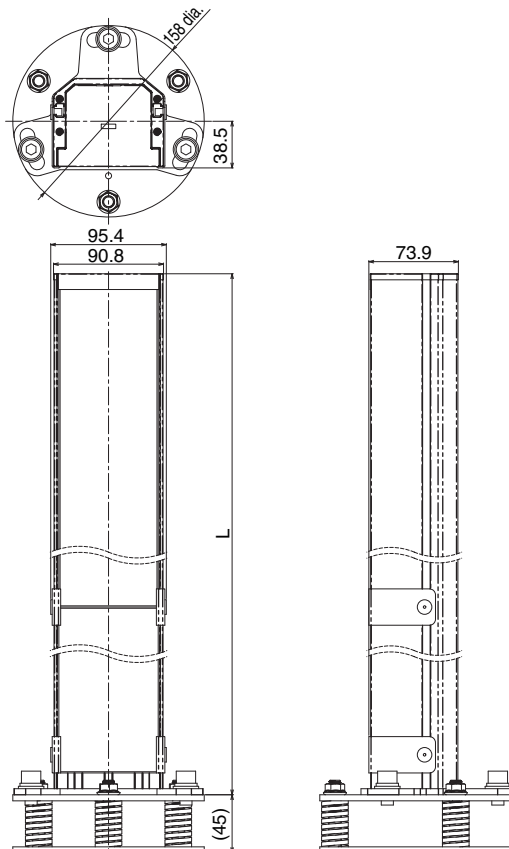

Model	Dimension L
F39-SML0990	990
F39-SML1310	1310
F39-SML1630	1630
F39-SML1950	1950

[Unit: mm]

■ Mirror Column (for Safety Multi-Light Beam F3SG-PGA-A/L) (F39-PML-□□□□, sold separately)

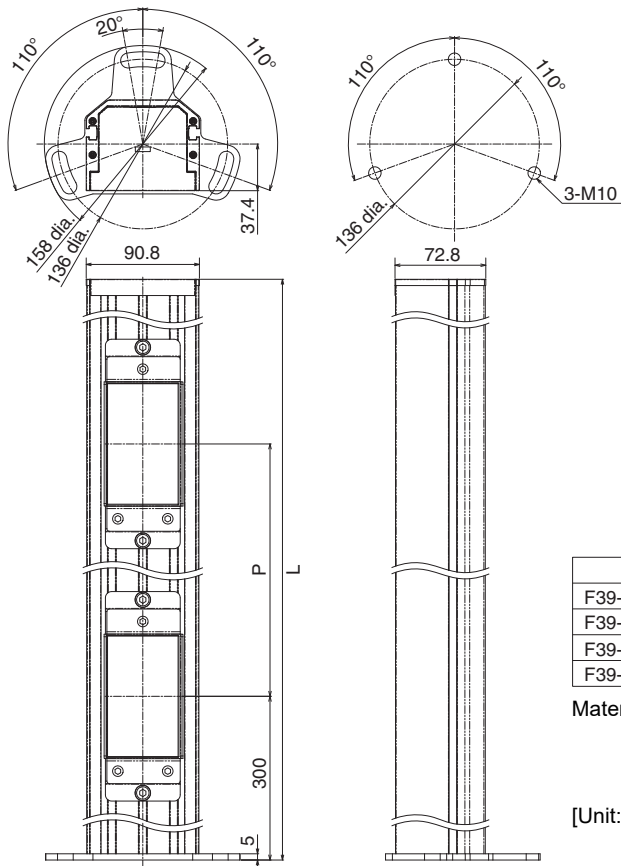

Model	Dimension L	Dimension P	Mirrors
F39-PML0990-2	990	500	2
F39-PML1310-3	1310	400	3
F39-PML1310-4		300	4
F39-PML1630-4	1630	400	4

Material: Aluminum alloy (Case)
 High rolled steel (Base & Mirror base)
 PBT resin (Cap)
 Glass mirror (Mirror)

[Unit: mm]

■ Assembly Dimensions

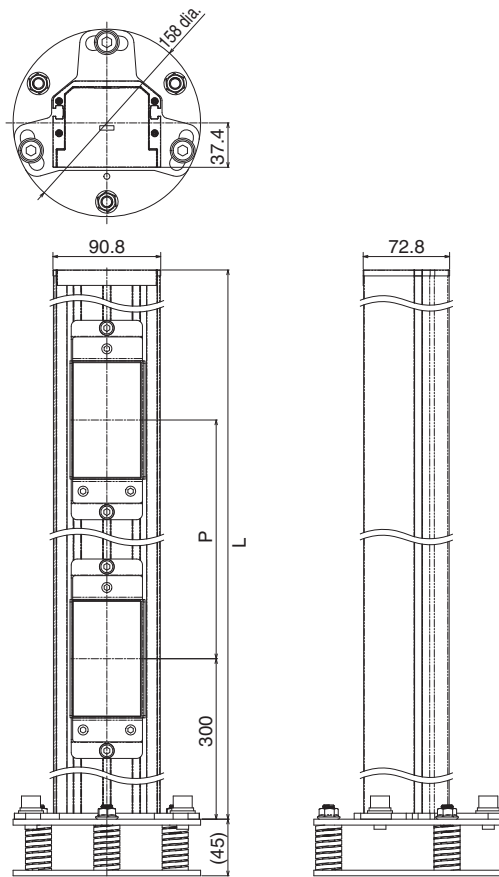

Model	Dimension L	Dimension P	Mirrors
F39-PML0990-2	990	500	2
F39-PML1310-3	1310	400	3
F39-PML1310-4		300	4
F39-PML1630-4	1630	400	4

[Unit: mm]

■ F3SG-SR IP69K Model Bracket (F39-LSGTB-K, sold separately)

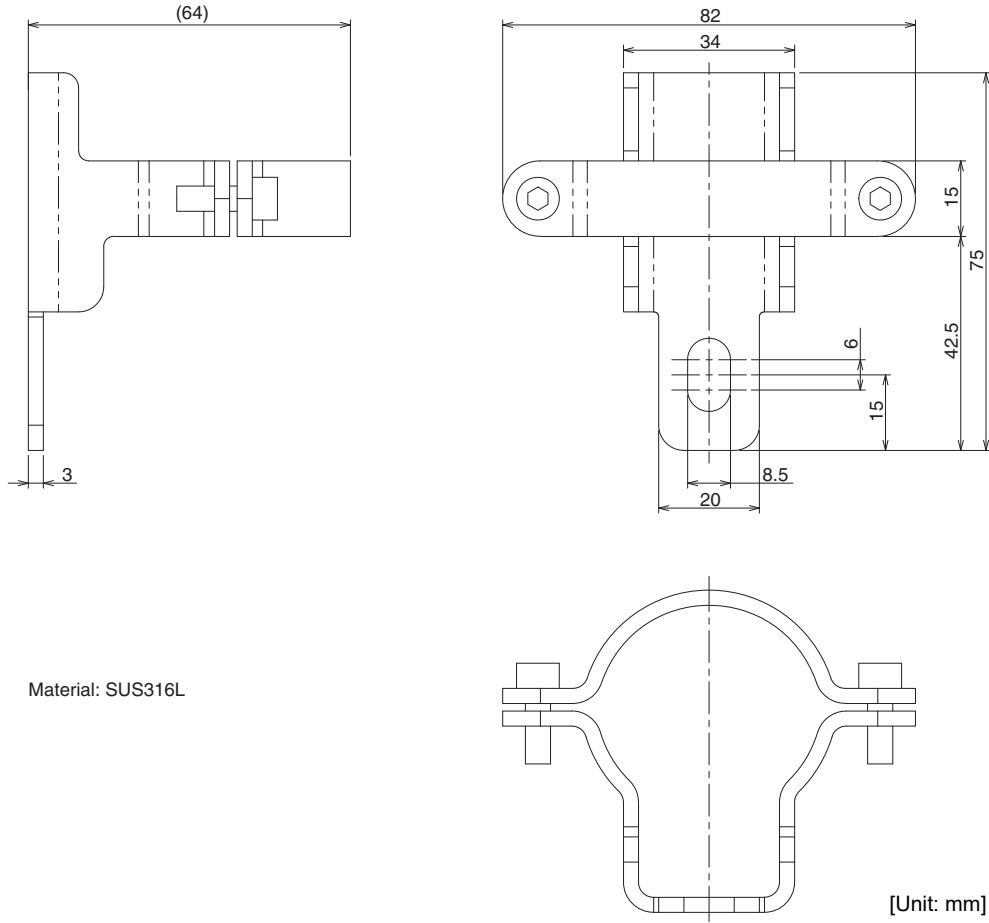

5-3. Mounting

5-3-1. Mounting Method

You can mount the F3SG-SR/PG in the following four ways.

- Mounting with Side-Mount Brackets (Intermediate Brackets) (F39-LSGF)
- Mounting with Adjustable Side-Mount Brackets (Intermediate Brackets) (F39-LSGA)
- Mounting with Adjustable Top/Bottom Brackets (F3SJ, F3SN Adapter) (F39-LSGTB-SJ) and Side-Mount Brackets (Intermediate Brackets) (F39-LSGF)
- Mounting with Adjustable Top/Bottom Brackets (F3SJ, F3SN Adapter) (F39-LSGTB-SJ) and Adjustable Side-Mount Brackets (Intermediate Brackets) (F39-LSGA)



CHECK! The mounting method and the number of required brackets of the Adjustable Top/Bottom Bracket (F3SG-RA/RE Adapter) (F39-LSGTB-RE) and the Adjustable Top/Bottom Bracket (MS4800, F3SR Adapter) (F39-LSGTB-MS) are the same as those for the Adjustable Top/Bottom Bracket (F3SJ, F3SN Adapter) (F39-LSGTBSJ) described below.

5-3-2. Number of Brackets Required

The numbers of brackets required according to the protective heights of the sensor are as follows:

- Mounting with Side-Mount Brackets (Intermediate Brackets) (F39-LSGF)

Protective height	Number of Side-Mount Brackets *
0160 to 1440	2
1520 to 2480	3

* The number of brackets required to mount either emitter or receiver or either emitter/receiver or passive mirror.

- Mounting with Adjustable Side-Mount Brackets (Intermediate Brackets) (F39-LSGA)

Protective height	Number of Adjustable Side-Mount Brackets *
0160 to 0280	1
0320 to 1440	2
1520 to 2480	3

* The number of brackets required to mount either emitter or receiver or either emitter/receiver or passive mirror.

- Mounting with Adjustable Top/Bottom Brackets (F3SJ, F3SN Adapter) (F39-LSGTB-SJ) and Side-Mount Brackets (Intermediate Brackets) (F39-LSGF)

Protective height	Number of Adjustable Top/Bottom Brackets *1	Number of Side-Mount Brackets *1
0160 to 0840	2	0
0880 to 1680	2	1
1760 to 2480	2	2

*1. The number of brackets required to mount either emitter or receiver or either emitter/receiver or passive mirror.

- Mounting with Adjustable Top/Bottom Brackets (F3SJ, F3SN Adapter) (F39-LSGTB-SJ) and Adjustable Side-Mount Brackets (Intermediate Brackets) (F39-LSGA)

Protective height	Number of Adjustable Top/Bottom Brackets *	Number of Adjustable Side-Mount Brackets *
0160 to 0840	2	0
0880 to 1680	2	1
1760 to 2480	2	2

* The number of brackets required to mount either emitter or receiver or either emitter/receiver or passive mirror.



CHECK! Make sure that the F3SG-SR/PG is securely mounted and its cables and connectors are properly connected.

5-3-3. Proper Mounting

5-3-3-1. Proper Mounting Orientation

Mount the emitter and receiver so that the detection surfaces of the emitter and receiver face in parallel to each other as shown below. The detection surfaces of the emitter and receiver not in parallel to each other or misaligned may fail to operate properly.

- Proper orientation:

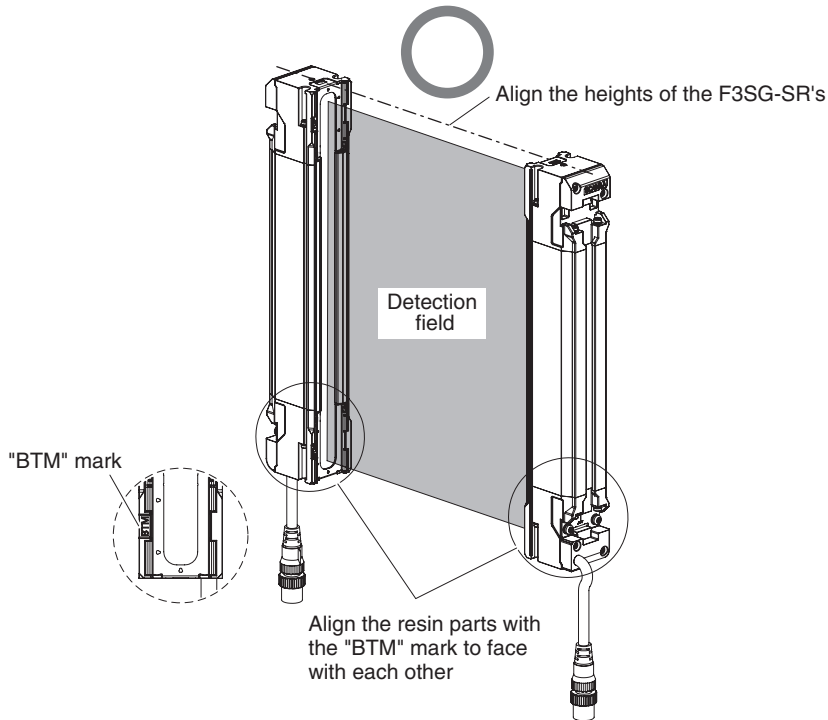

- Wrong orientation:

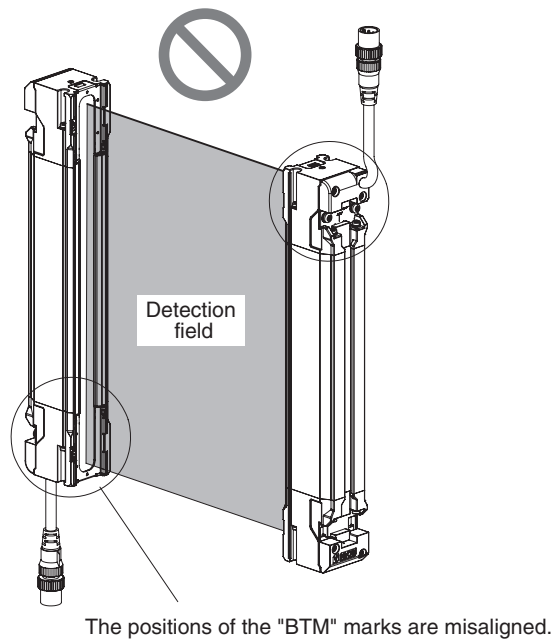

CHECK!

No wiring is needed for the passive mirror of F3SG-PGA-C. Be sure to mount it with aligning the "BTM" marking correctly.

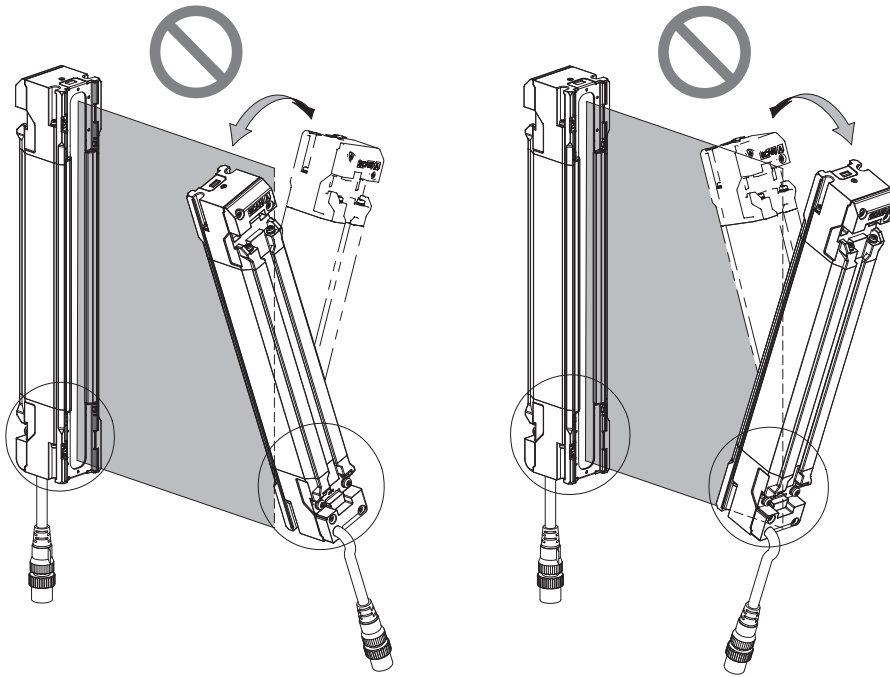

The detection surfaces of the emitter and receiver are not in parallel to each other.

Mount the F3SG-SR/PG on a flat surface. Mounting it on an inclined surface cause the orientation of the beams to tilt with respect to the floor, resulting in misalignment of the beams of the emitter and receiver. Mount the emitter and receiver on a level surface by checking the lean by a level.

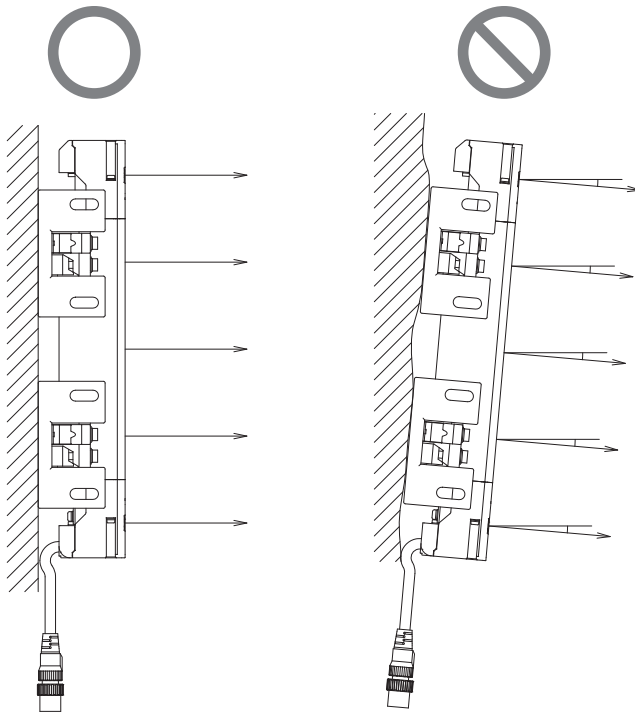

Mounted on a level, flat surface.

Mounted on an inclined, uneven surface.

5-3-4. Mounting Procedure

5-3-4-1. Mounting with Side-Mount Brackets (Intermediate Brackets) (F39-LSGF)

- Securely tighten the screws to fix the Side-Mount Bracket to the mounting position of the wall surface. When using more than one Side-Mount Brackets, align them in the same line using the sides of the brackets that do not face the wall, before attaching the brackets to the sensor. (Fig. 1)

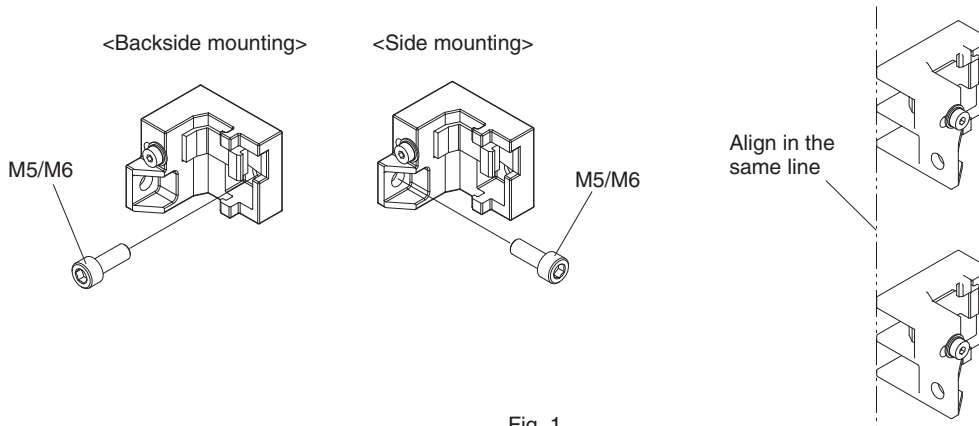

Fig. 1



Screws to mount the brackets to the wall are not included.

CHECK!

- Fully loosen the Mounting Screws (hexagon socket head cap screw (M4×22)). Fit the Brackets (1) and (2) to the backside of the sensor housing so that the groove of the backside of the housing receives the hooks of the Brackets (1) and (2). (Fig. 2)

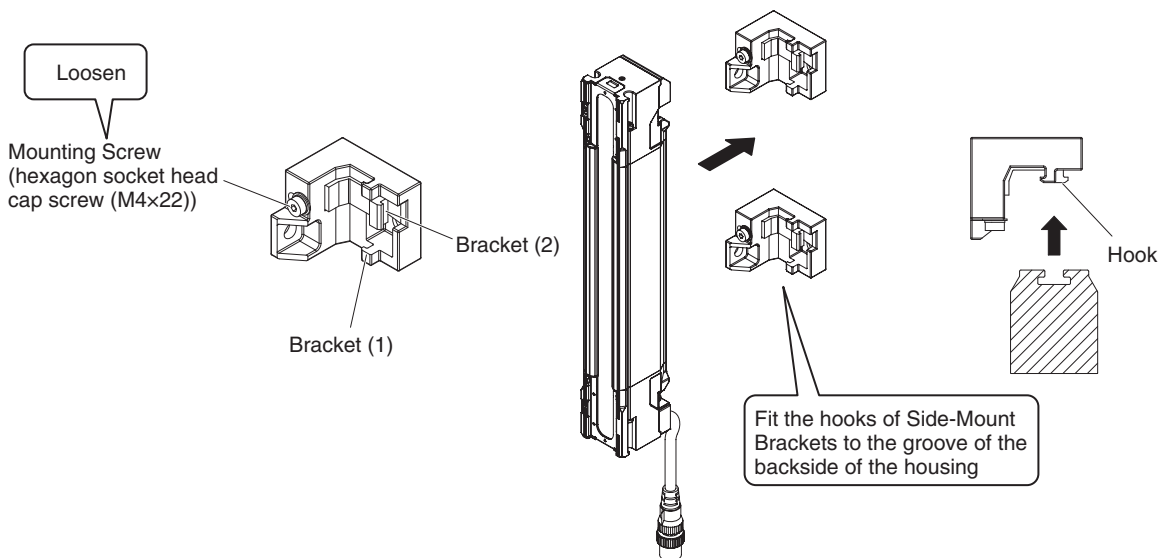

Fig. 2

- Securely tighten the Mounting Screws to fix the Side-Mount Bracket to the yellow area of the sensor housing. The recommended torque to tighten the Mounting Screws is 3.0 N•m. Then loosen the Alignment Screws (Fig. 3)

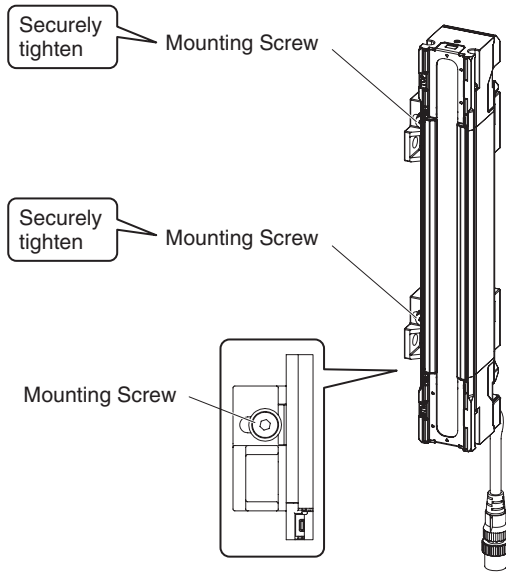

Fig. 3



Tightening screws with a torque that considerably exceeds the recommended torque may cause failure.

5-3-4-2. Mounting with Adjustable Side-Mount Brackets (Intermediate Brackets) (F39-LSGA)

- Securely tighten the screws to fix the Adjustable Side-Mount Bracket to the mounting position of the wall surface. When using more than one Adjustable Side-Mount Brackets, align them in the same line using the sides of the brackets that do not face the wall, before attaching the bracket to the sensor. (Fig. 1)

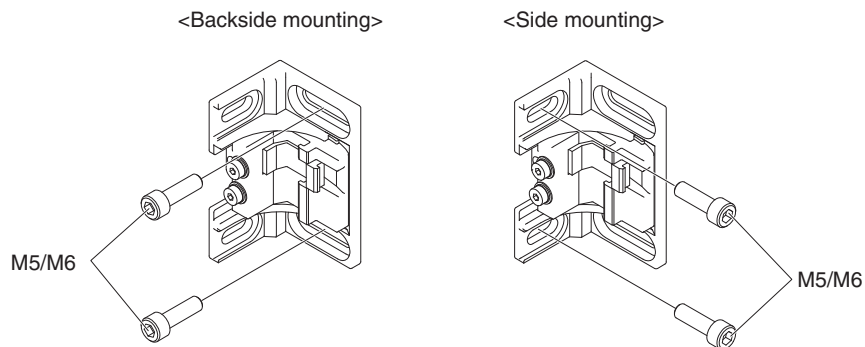

Fig. 1



Screws to mount the brackets to the wall are not included.

2. Fully loosen the Mounting Screws (hexagon socket head cap screw (M4×22)). Fit the Brackets (1) and (2) to the backside of the sensor housing so that the groove of the backside of the housing receives the hooks of the Brackets (1) and (2). (Fig. 2)

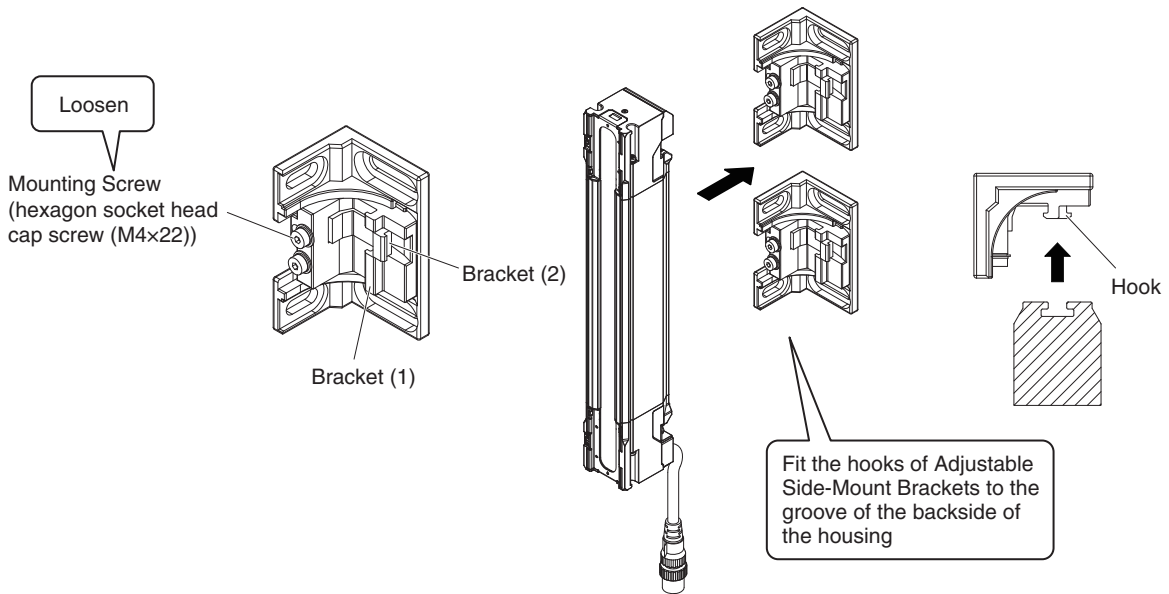

Fig. 2

3. Securely tighten the Mounting Screws to fix the Adjustable Side-Mount Bracket to the yellow area of the sensor housing. The recommended torque to tighten the Mounting Screws is 3.0 N•m. Then loosen the Alignment Screws (hexagon socket head cap screws (M4×22)). (Fig. 3)

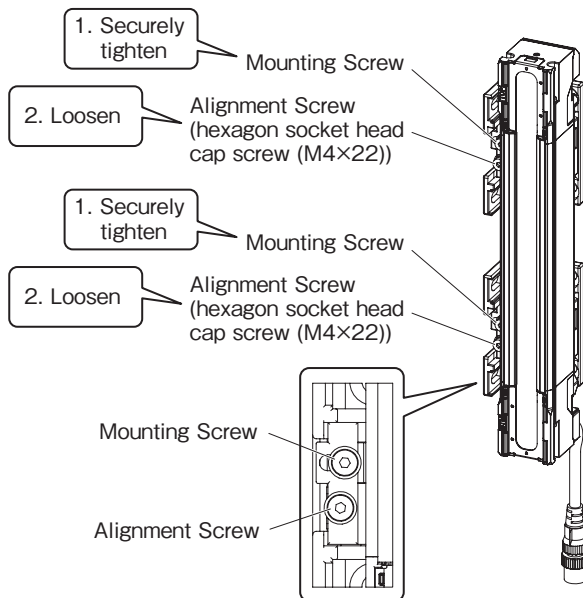

Fig. 3



Tightening screws with a torque that considerably exceeds the recommended torque may cause failure.

4. Power the emitter and receiver on to perform beam alignment.
For more information on the beam alignment procedure, refer to 5-3-4-5. *Mounting IP69K Model.* (Fig. 4)

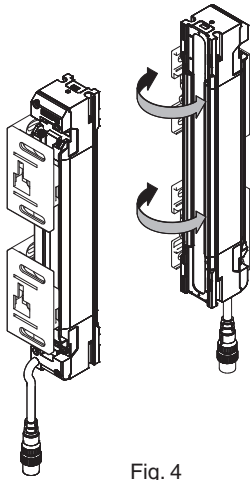
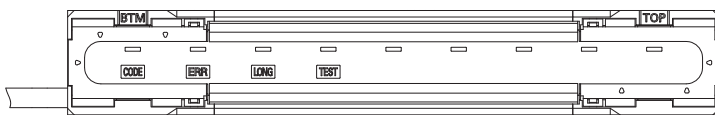

Fig. 4

F3SG-SR, F3SG-SR-K

<EMITTER>



Marking on the side (Emitter)

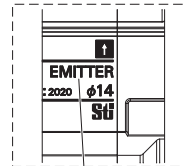

"EMITTER" mark

<RECEIVER>

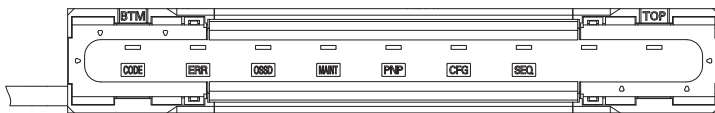

Marking on the side (Receiver)

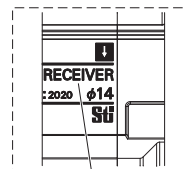

"RECEIVER" mark

Fig. 5

F3SG-PGA-A/L

<EMITTER>



Marking on the side (Emitter)

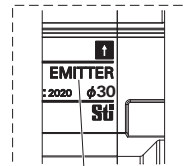

"EMITTER" mark

<RECEIVER>



Marking on the side (Receiver)

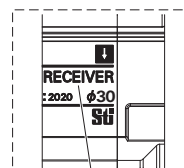

"RECEIVER" mark

Fig. 5

F3SG-PGA-C

<EMITTER/RECEIVER>



Marking on the side
(Emitter/Receiver)



"ACTIVE" mark

<PASSIVE MIRROR>

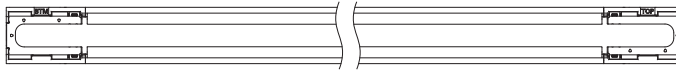

Marking on the side
(Passive mirror)



"PASSIVE" mark

Fig. 5



CHECK!

- The angle adjustment range of the Adjustable Side-Mount Brackets is $\pm 15^\circ$.

- Securely tighten the Alignment Screws to fix the Adjustable Side-Mount Bracket to the sensor housing. The recommended torque to tighten the Alignment Screws is 3.0 N•m. (Fig. 6)

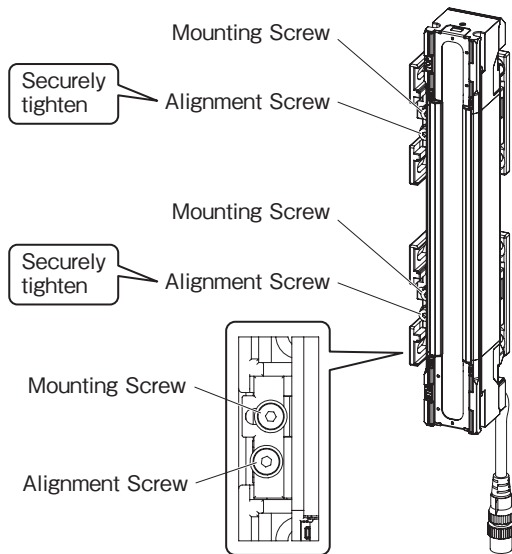

Fig. 6



CHECK!

Tightening screws with a torque that considerably exceeds the recommended torque may cause failure.

5-3-4-3. Mounting with Adjustable Top/Bottom Brackets (F3SJ, F3SN Adapter) (F39-LSGTB-SJ) and Side-Mount Brackets (Intermediate Brackets) (F39-LSGF)



The mounting method of the Adjustable Top/Bottom Bracket (F3SG-RA/RE Adapter) (F39-LSGTB-RE) or the Adjustable Top/Bottom Bracket (MS4800, F3SR Adapter) (F39-LSGTB-MS) are the same as that of the Adjustable Top/Bottom Bracket (F3SJ, F3SN Adapter) (F39-LSGTBSJ).

CHECK!

1. Loosen the Alignment Screws (hexagon socket head cap screw (M4×7)) of the Top/Bottom Bracket (3) and change the angle of the Top/Bottom Bracket (3) according to its mounting direction. Then loosen the Mounting Screws (low head hexagon socket head cap screw (M4×7)) of Top/Bottom Bracket (2). (Fig. 1)

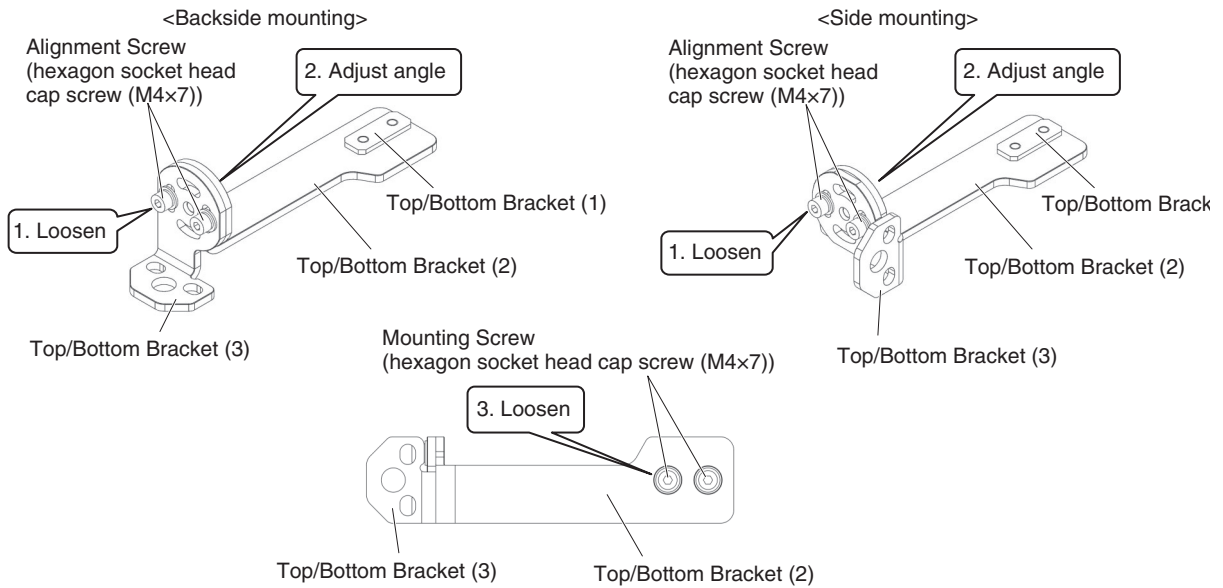

Fig. 1

- Slide the Top/Bottom Bracket (1) in the grooves of the sensor housing. Adjust the Top/Bottom Bracket to the mounting position of the wall surface. Make sure to contact the whole body of the Top/Bottom Bracket (1) with the groove of the yellow area of the housing. Securely tighten the Mounting Screws to fix the Top/Bottom Bracket to the housing of the sensor. The recommended torque to tighten the Mounting Screws of the Top/Bottom Bracket is 3.0 N•m. (Fig. 2)

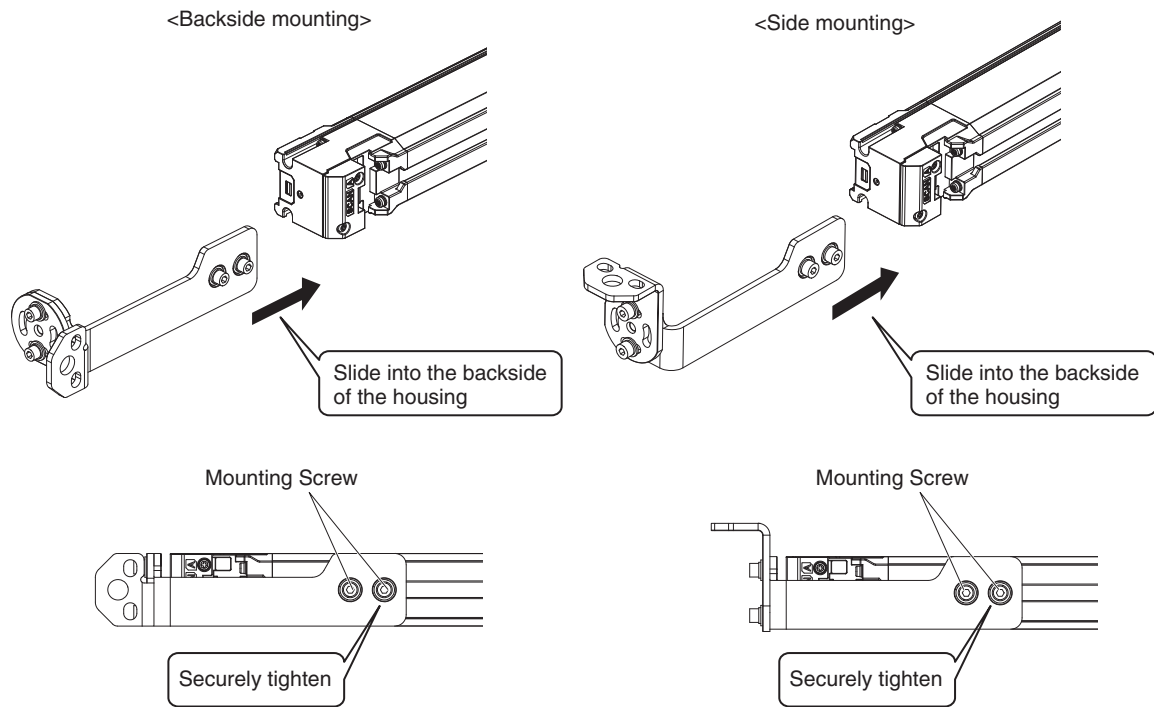

Fig. 2



Tightening screws with a torque that considerably exceeds the recommended torque may cause failure.

CHECK!

- Securely tighten screws to fix the Side-Mount Bracket to the mounting position of the wall surface. When more than one Side-Mount Brackets, align them in the same line using the sides of the brackets that do not face the wall, before attaching the brackets to the sensor. (Fig. 3)

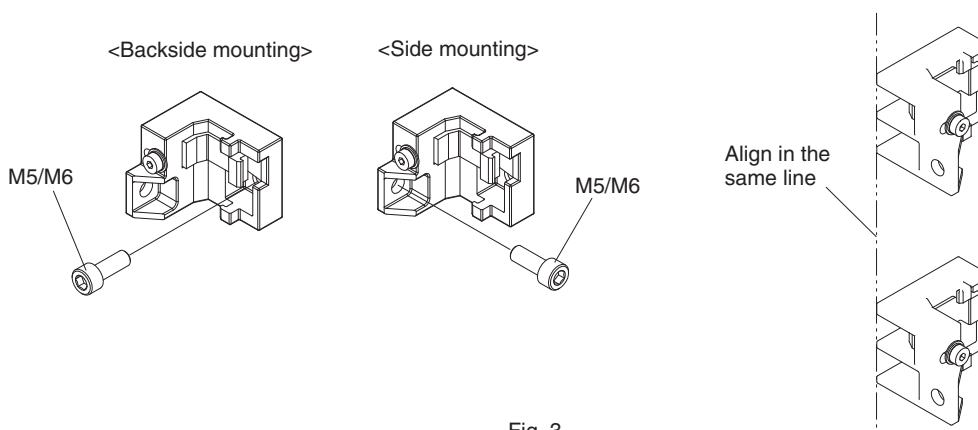

Fig. 3



Screws to mount the brackets to the wall are not included.

CHECK!

4. Fully loosen the Mounting Screw (hexagon socket head cap screw (M4×22)) of the Side-Mount Bracket. (Fig. 4) Then slide the hooks of the Brackets (1) and (2) in the groove of the backside of the sensor housing. (Fig. 5)

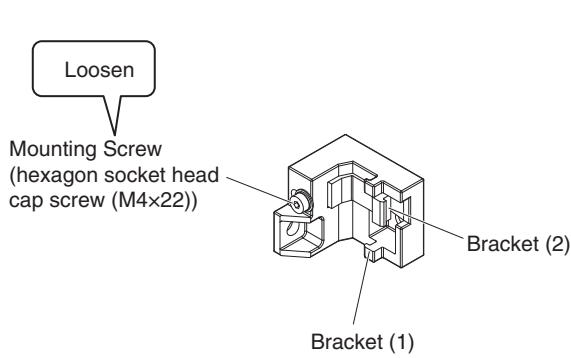

Fig. 4

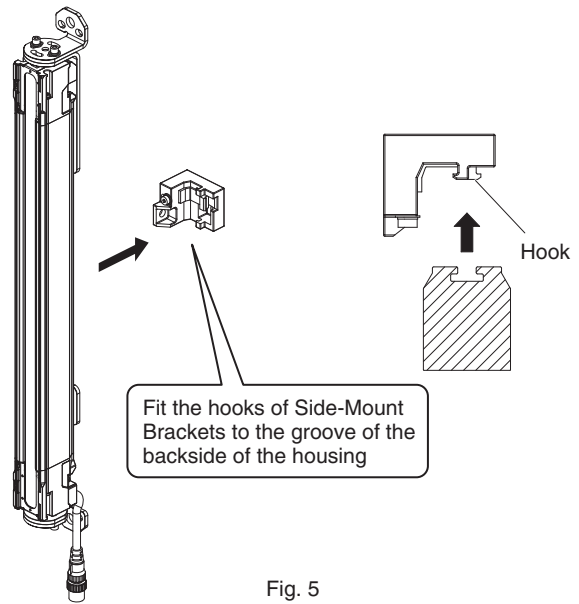

Fig. 5

5. Securely tighten the Mounting Screw to fix the Side-Mount Bracket to the sensor housing. The recommended torque to tighten the Mounting Screw of the Side-Mount Bracket is 3.0 N•m. (Fig. 6)

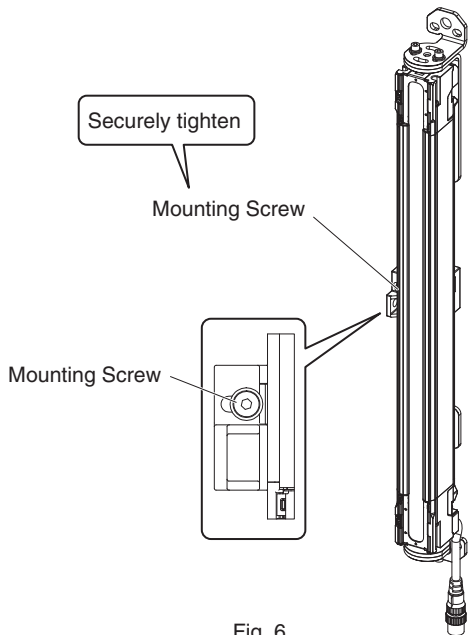

Fig. 6



Tightening screws with a torque that considerably exceeds the recommended torque may cause failure.

6. Securely tighten screws to fix the Top/Bottom Bracket to the mounting position of the wall surface. (Fig.7)

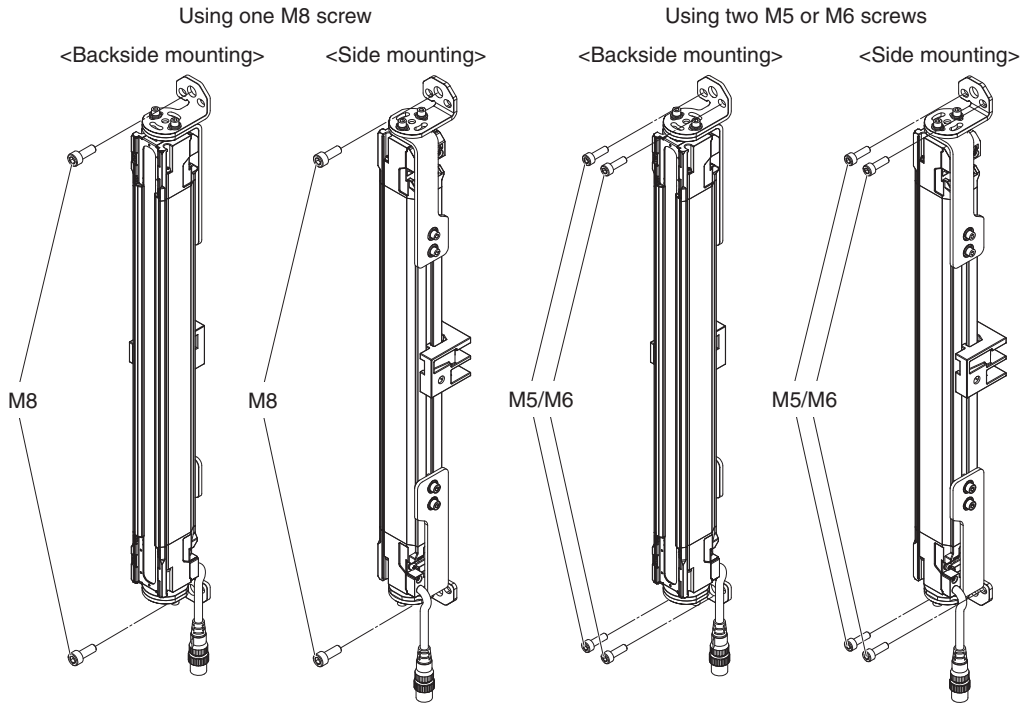

Fig. 7



Screws to mount the brackets to the wall are not included.

7. Securely tighten the Alignment Screw of the Top/Bottom Bracket to fix the bracket to the sensor housing. The recommended torque to tighten the Alignment Screw is 3.0 N•m. (Fig. 8)

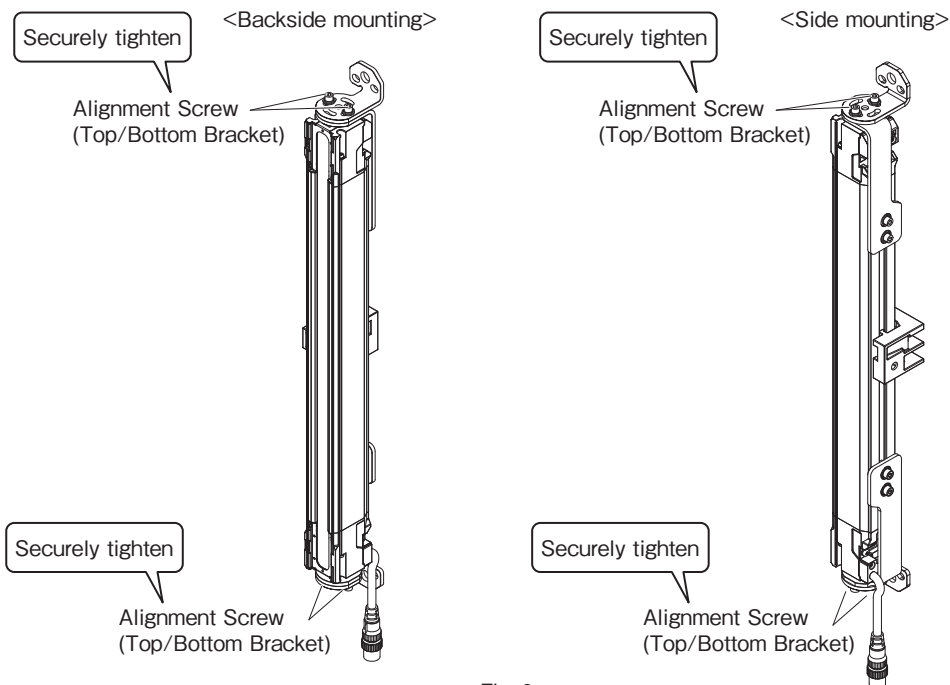

Fig. 8



Tightening screws with a torque that considerably exceeds the recommended torque may cause failure.

5-3-4-4. Mounting with Adjustable Top/Bottom Brackets (F3SJ, F3SN Adapter) (F39-LSGTB-SJ) and Adjustable Side-Mount Brackets (Intermediate Brackets) (F39-LSGA)



The mounting method of the Adjustable Top/Bottom Bracket (F3SG-RA/RE Adapter) (F39-LSGTB-RE) or the Adjustable Top/Bottom Bracket (MS4800, F3SR Adapter) (F39-LSGTB-MS) are the same as that of the Adjustable Top/Bottom Bracket (F3SJ, F3SN Adapter) (F39-LSGTBSJ).

1. Loosen the Alignment Screws (hexagon socket head cap screw (M4×7)) of the Top/Bottom Bracket (3) and change the angle of the Top/Bottom Bracket (3) according to its mounting direction. Then loosen the Mounting Screws (low head hexagon socket head cap screw (M4×7)) of Top/Bottom Bracket (2). (Fig. 1)

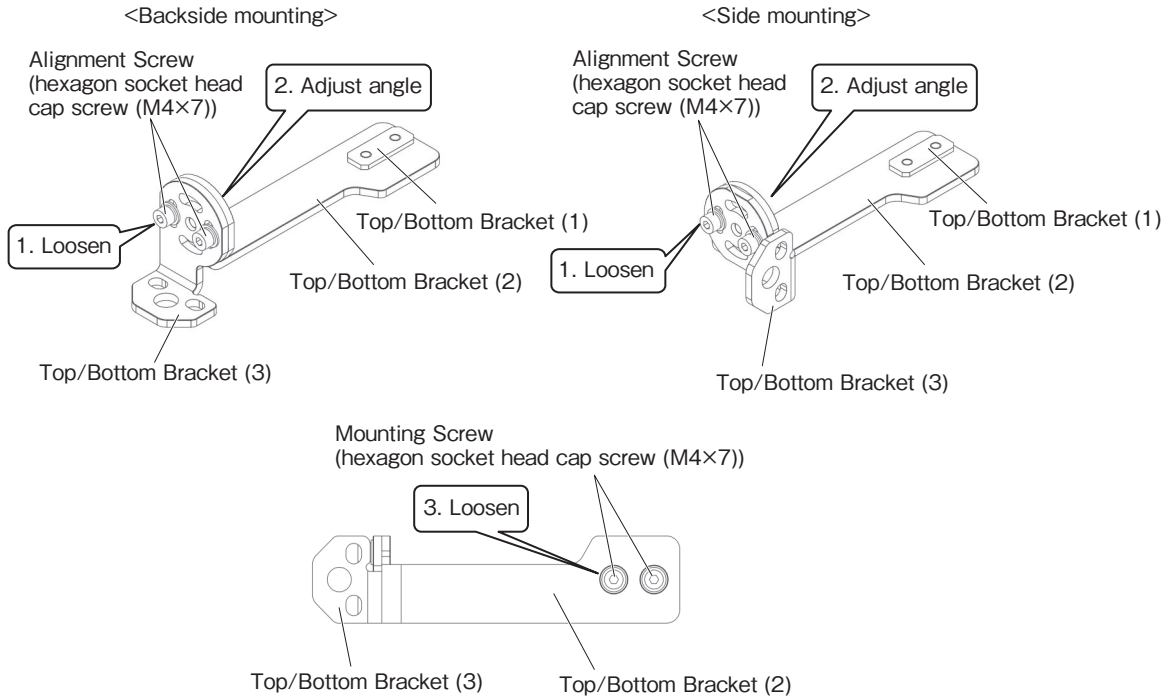

Fig. 1

- Slide the Top/Bottom Bracket (1) in the grooves of the sensor housing. Adjust the Top/Bottom Bracket to the mounting position of the wall surface. Make sure to contact the whole body of the Top/Bottom Bracket (1) with the groove of the yellow area of the housing. Securely tighten the Mounting Screws to fix the Top/Bottom Bracket to the housing of the sensor. The recommended torque to tighten the Mounting Screws of the Top/Bottom Bracket is 3.0 N•m. (Fig. 2)

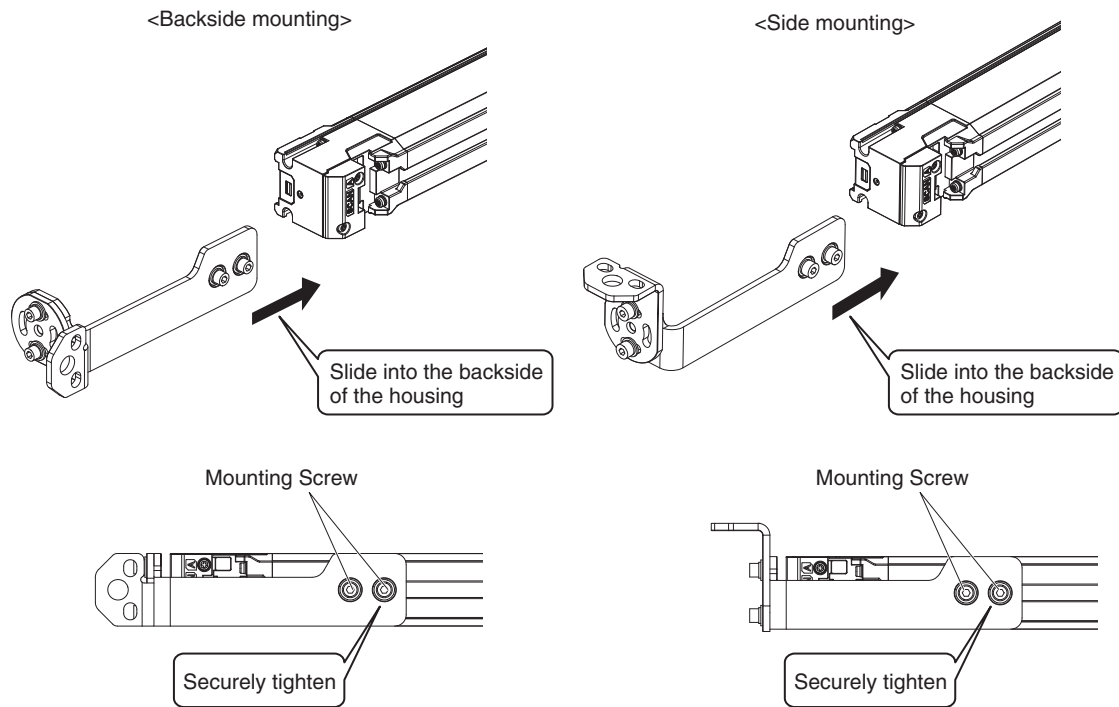

Fig. 2



Tightening screws with a torque that considerably exceeds the recommended torque may cause failure.

CHECK!

- Securely tighten screws to fix the Adjustable Side-Mount Bracket to the mounting position of the wall surface. When using more than one Adjustable Side-Mount Brackets, align them in the same line using the sides of the brackets that do not face the wall, before attaching the brackets to the sensor. (Fig. 3)

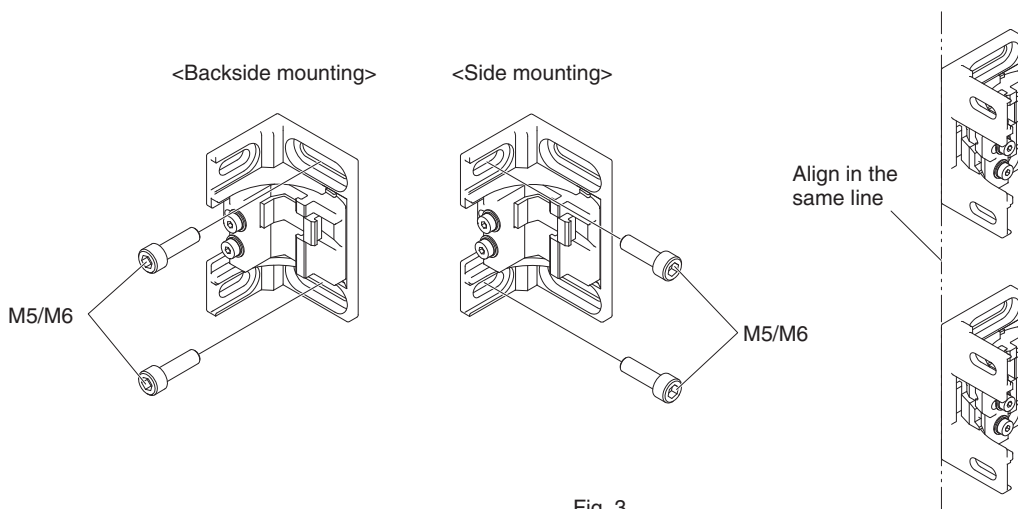

Fig. 3



Screws to mount the brackets to the wall are not included.

CHECK!

4. Fully loosen the Mounting Screw (hexagon socket head cap screw (M4×22)) of the Adjustable Side-Mount Bracket. (Fig. 4) Then slide the hooks of the Brackets (1) and (2) in the groove of the backside of the sensor housing. (Fig. 5)

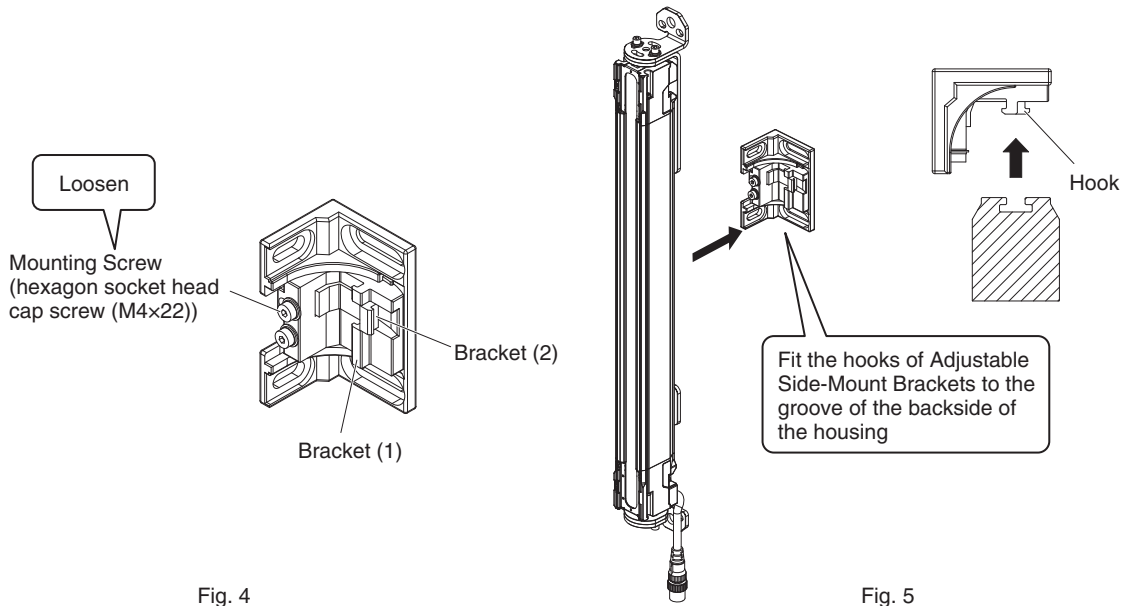

Fig. 4

Fig. 5

5. Securely tighten the Mounting Screw to fix the Adjustable Side-Mount Bracket to the sensor housing. The recommended torque to tighten the Mounting Screw of the Adjustable Side-Mount Bracket is 3.0 N•m. Then loosen the Alignment Screw (hexagon socket head cap screw (M4×22)) of the Adjustable Side-Mount Bracket. (Fig. 6)

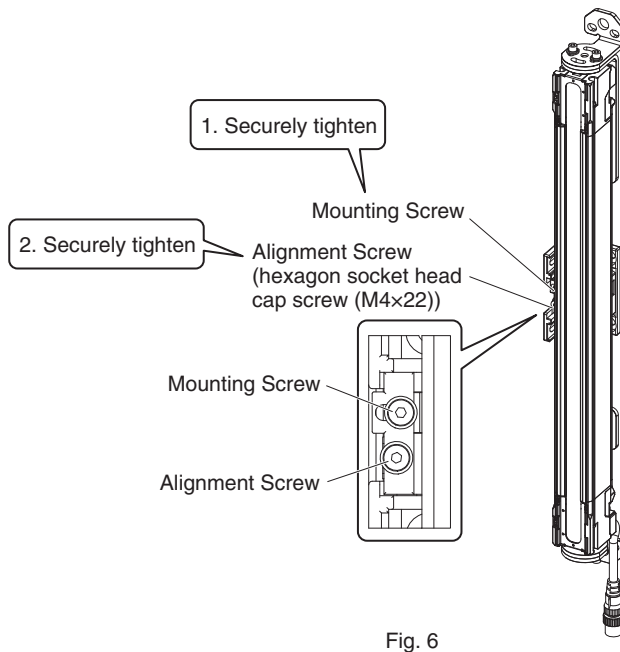

Fig. 6

6. Securely tighten screws to fix the Top/Bottom Bracket to the mounting position of the wall surface. (Fig.7)

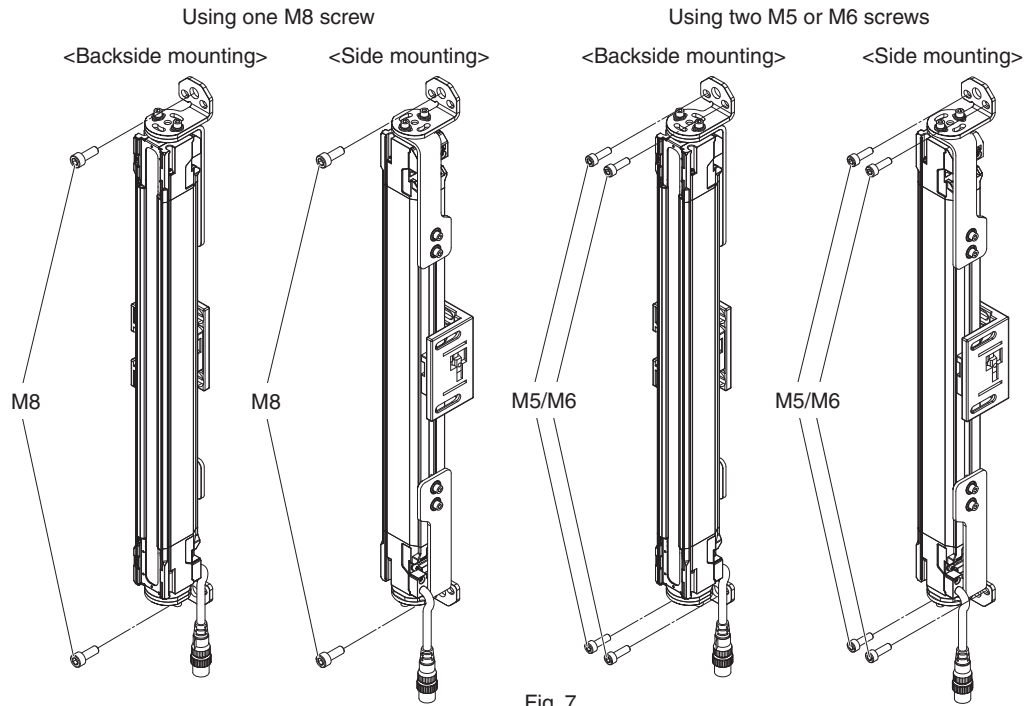

Fig. 7



Screws to mount the brackets to the wall are not included.

CHECK!

7. Power the emitter and receiver on to perform beam alignment. Move the emitter and receiver from side to side (Fig. 8) to check the state of the beams. For more information on the beam alignment procedure, refer to 5-3-4-5. *Mounting IP69K Model.*

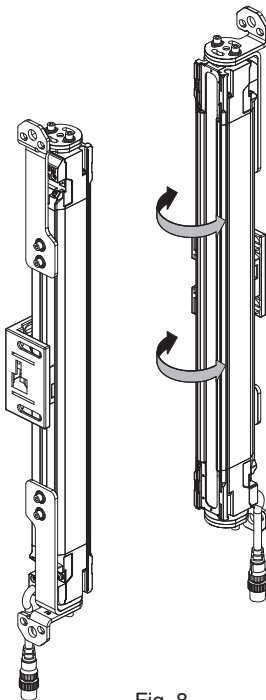

Fig. 8



CHECK!

- The angle adjustment range is $\pm 22.5^\circ$ when using the Top/Bottom Brackets only.
- The angle adjustment range is $\pm 15^\circ$ when using the Top/Bottom Brackets and Adjustable Side-Mount Bracket(s) together.
- For the way to distinguish the emitter from the receiver or distinguish the emitter/receiver from the passive mirror, refer to Procedure 4 of 5-3-4-2. *Mounting with Adjustable Side-Mount Brackets (Intermediate Brackets) (F39-LSGA).*

- Securely tighten the Alignment Screws of the Top/Bottom Bracket and Adjustable Side-Mount Bracket to fix the bracket to the sensor housing. The recommended torque to tighten the Alignment Screws is 3.0 N•m. (Fig. 10)

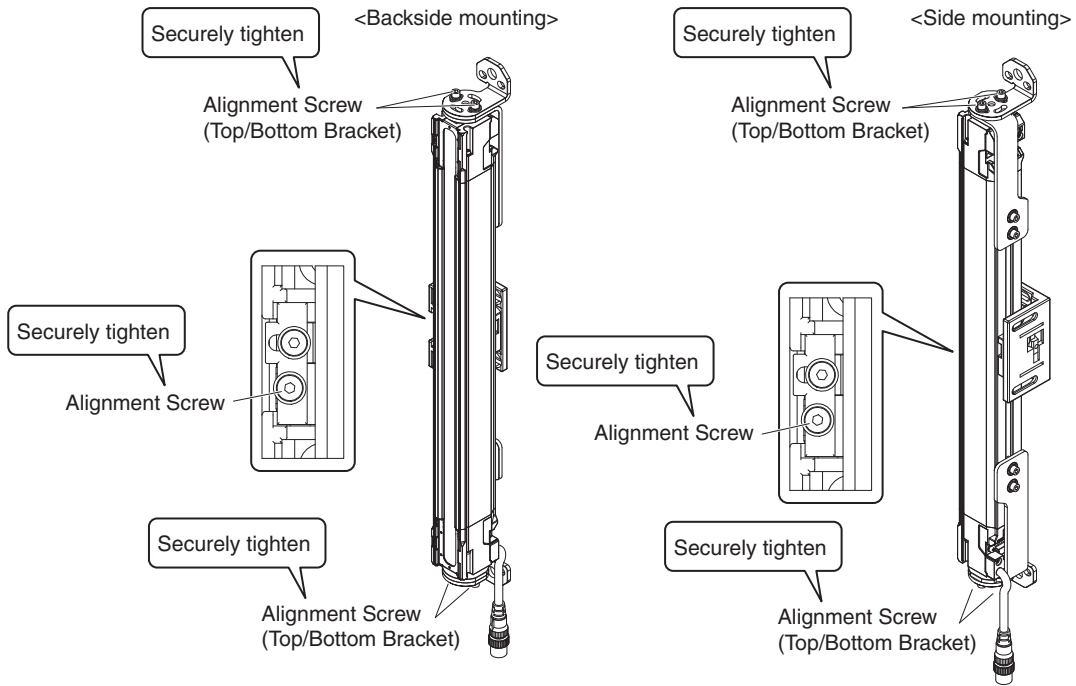

Fig. 9



Tightening screws with a torque that considerably exceeds the recommended torque may cause failure.

5-3-4-5. Mounting IP69K Model

1. Securely tighten the screws to fix the separately sold bracket (F39-LSGTB-K) to the mounting position of the wall surface (Fig. 1).

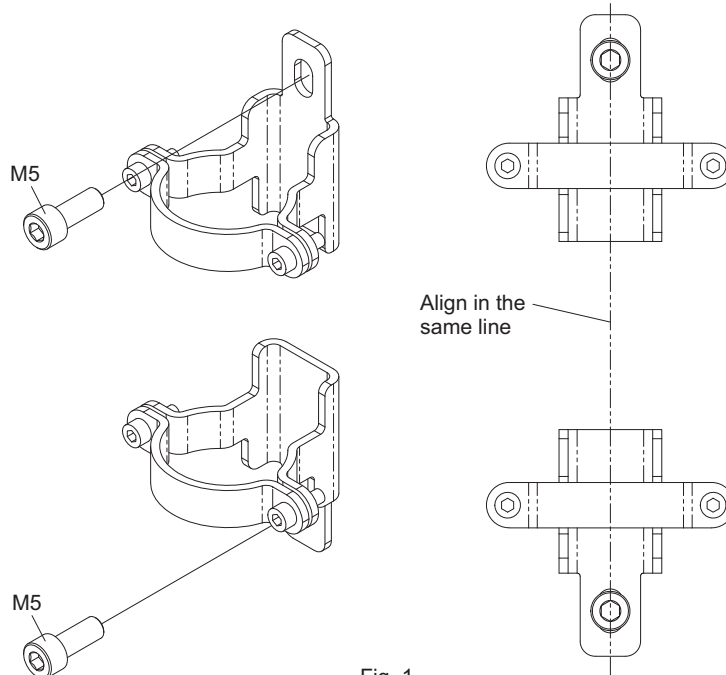

Fig. 1



Screws to mount the brackets to the wall are not included.

2. Loosen the alignment screws of the bracket (hexagon socket head cap screw (M5×15)) to remove the bracket (1) (Fig. 2).

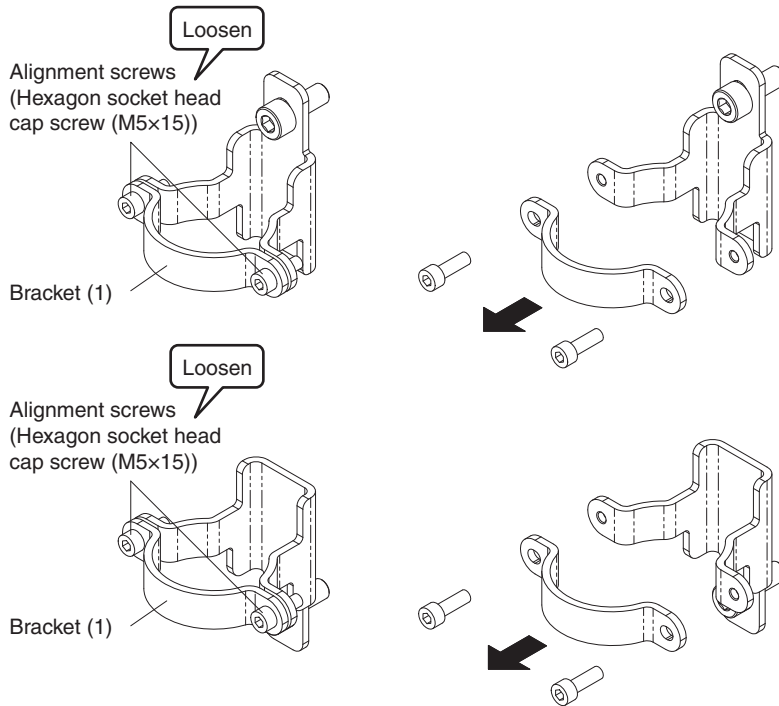

Fig. 2

3. Fit the groove of the sensor's cap to the bracket (2), mount the bracket (1), and tighten the alignment screws until the sensor no longer drops (Fig. 3).

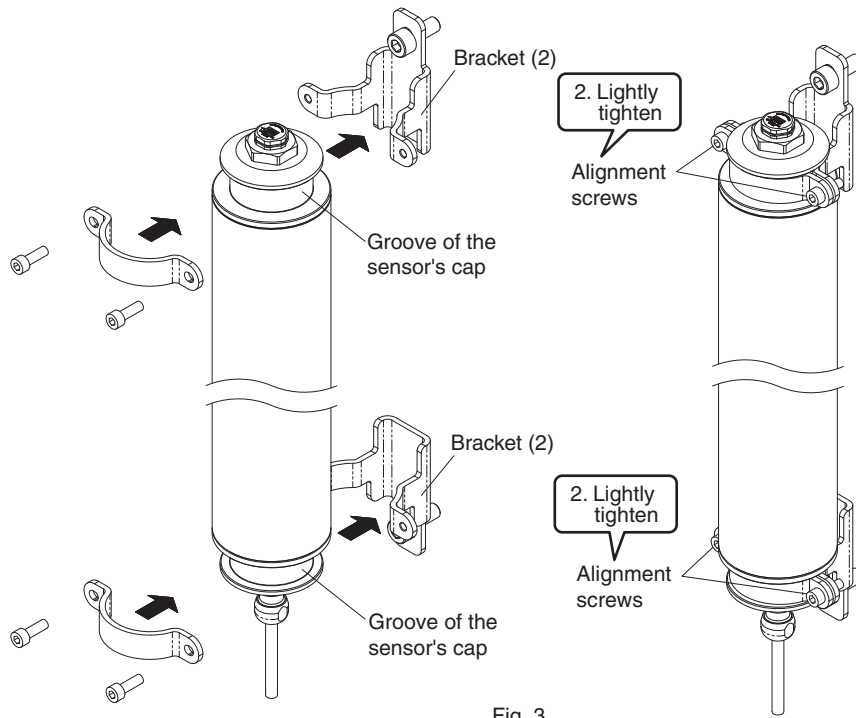

Fig. 3

4. Power the emitter and receiver on to perform beam alignment (Fig. 4).
For more information on the beam alignment procedure, refer to 5-3-5. *Beam Alignment Procedure*.

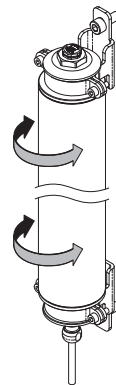

Fig. 4



- There is no restriction in the angle adjustment range.
- For the way to distinguish the emitter from the receiver or distinguish the emitter/receiver from the passive mirror, refer to Procedure 4 of 5-3-4-2. *Mounting with Adjustable Side-Mount Brackets (Intermediate Brackets) (F39-LSGA)*.

- Securely tighten the beam alignment screws to fix the sensor housing. The recommended torque to tighten these screws is 3.0 N•m (Fig. 5).

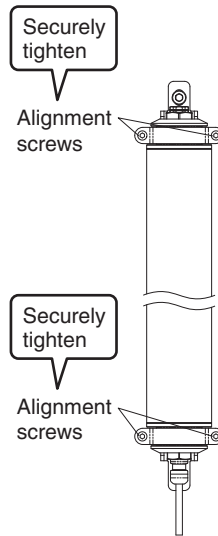

Fig. 5



Tightening screws with a torque that considerably exceeds the recommended torque may cause failure.

5-3-5. Beam Alignment Procedure



The Adjustable Side-Mount Bracket (Intermediate Bracket) (F39-LSGA) and Adjustable Top/Bottom Bracket (F3SJ, F3SN Adapter) (F39-LSGTB-SJ) allow beam alignment after fixing the brackets to a wall surface. The Side-Mount Bracket (Intermediate Bracket) (F39-LSGF) does not allow beam alignment.

1. Verify the following points:
 - The optical surface of the sensor is clean.
 - There is no interrupting object in the detection zone of the sensor.

2. Align the beams of the sensor.

Move the emitter and receiver, the emitter/receiver, and the passive mirror, from side to side to check the state of the beams with the ABI indicators or the TOP and BTM indicators. When the stable unblocked state is established, the TOP and BTM indicators turns blue and the ABI indicators change the color at every second from green -> orange -> green -> orange -> green, indicating that the beam alignment is complete.

Adjust the angle of the sensor to bring the beams in the stable unblocked state.



1-4. LED Indicators on F3SG-SR/PG









- The ABI indicators are for F3SG-SRA and F3SG-PG. The TOP and BTM indicators are for the F3SG-SRB only.
- The ABI indicators of the emitter are illuminated only in the case the Wired Synchronization is enabled and are off in the case the Optical Synchronization is enabled.
- Perform beam alignment to the primary sensor first, when using the F3SG-SR in a cascade connection.
- It is recommended to use the Light Level Monitoring with the SD Manager 3 for beam alignment. Refer to Chapter 4 Setting with SD Manager 3 for more information.
- The ABI indicators (green) will not be illuminated if the blanking function is used and there is a blocking object in the detection zone. Perform beam alignment again to illuminate the ABI indicators (green) after setting the blanking function.
- If any of the ABI indicators (green) or either TOP or BTM indicator is not illuminated, check if the emitter and receiver are mounted parallel and at the same height.

3. When the Start Interlock is disabled, the safety outputs are turned to the ON state simultaneously with the establishment of the stable unblocked state. Confirm that the ABI indicators are illuminated in green and the TOP and BTM indicators are illuminated in blue when the safety outputs are in the ON state.

When the Start Interlock is enabled, the ABI or TOP/BTM indicators are turned off simultaneously with the establishment of the stable unblocked state. Confirm that the ABI indicators are illuminated in green and TOP and BTM indicators are illuminated in blue when the Start Interlock is released (and the safety outputs are in the ON state) by turning the RESET input in the ON state.

5-4. Wiring

5-4-1. Wiring Precautions

⚠ WARNING	
Double or reinforced insulation from hazardous voltage must be applied to all input and output lines. Failure to do so may result in electric shock.	
When using the PNP output, connect the load between the output and 0 V line. When using the NPN output, connect the load between the output and +24 VDC line. Connecting the load between the output and a different power supply line from the above line will result in a dangerous condition because the operation mode of safety outputs are reversed to "Dark-ON".	
When using the PNP output, do not ground +24 VDC line. When using the NPN output, do not ground 0 V line. Otherwise, a ground fault may turn the safety outputs ON, resulting in a failure of stopping the machine.	
Configure the system by using the optimal number of safety outputs that satisfy the requirements of the necessary safety category.	
Do not connect each line of the F3SG-SR/PG to a DC power supply of higher than 24 VDC+20%. Also, do not connect it to an AC power supply. Failure to do so may result in electric shock.	
Make sure to perform wiring while the power supply is OFF.	

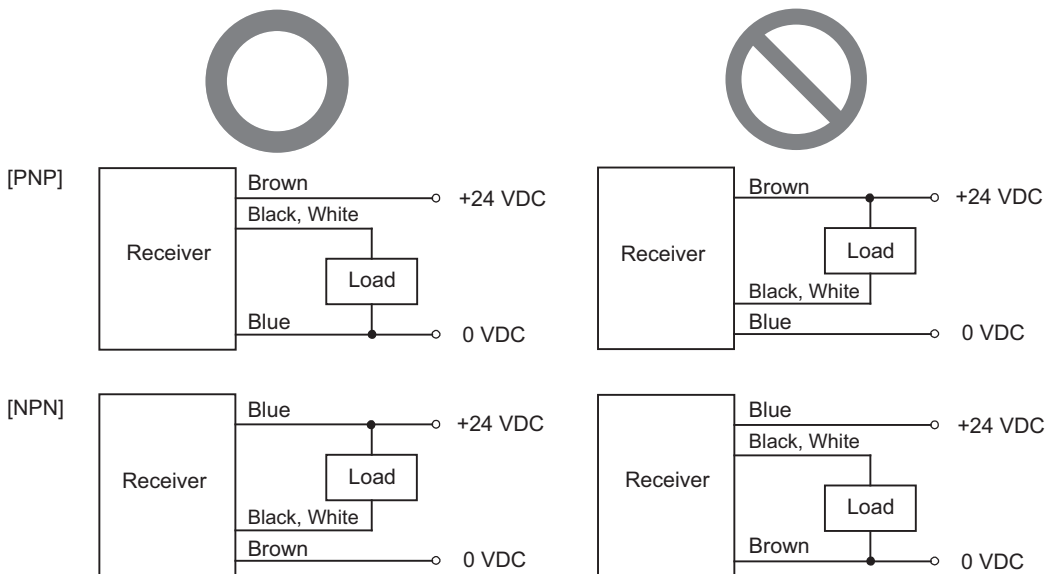

5-4-2. Power Supply Unit

WARNING

For the F3SG-SR/PG to comply with IEC 61496-1 and UL 508, the DC power supply unit must satisfy all of the following conditions:



- The DC power supply operates within the rated power voltage (24 VDC \pm 20%).
- The DC power supply has tolerance against the total rated current of devices if it is connected to multiple devices.
- The DC power supply complies with EMC directives (industrial environment).
- Double or reinforced insulation is applied between the primary and secondary circuits.
- The DC power supply has an automatic recovery type of overcurrent protection characteristics.
- Output holding time is 20 ms or longer.
- The DC power supply satisfies output characteristic requirements for class 2 circuit or limited voltage current circuit defined by UL 508. (Refer to Note below.)
- The DC power supply complies with laws and regulations, regarding EMC and electrical equipment safety, of the country or region where the F3SG-SR/PG is used. (For example, in EU, the power supply must comply with the EMC Directive and the Low Voltage Directive.)

Note:

To prevent a fire, the secondary circuit of the power supply must satisfy either of the following conditions in accordance with UL 508:

- As with secondary winding of isolation transformer, there must be a limited current voltage circuit to which isolated power supply provides power, and the "current is limited to 8 A max. (including short-circuit)" or "circuit protection such as a fuse is used to limit the current, which has a rating of 4.2A max." (24 VDC power supply).

Recommended power supply: OMRON S8VK-S (30 W or 60 W)

These products are UL-Listed (UL 508, class 2 power supply), CE marking compatible (EMC/Low Voltage Directive).

- Class 2 power supply unit complying with UL 1310, or a circuit using 2 transformers complying with UL 1585 as a power supply.



Sharing the power supply with other devices may cause the F3SG-SR/PG to be affected by noise or voltage drop. It is recommended that the F3SG-SR/PG use a dedicated power supply, not shared with other devices.

5-4-3. Cable Connections

WARNING

Extension of the cable must be within a specified length. If it isn't, safety functions may not work properly, resulting in danger.



For the restrictions on the cable extension, refer to 1-5. *Ratings and Specifications*.

Perform wiring according to the following procedure.

- 1.** Connect a gray Root-Straight Cable for the emitter (F39-JG□C-L, sold separately) or Root-Plug Cable for extension for emitter (F39-JGR3K-L, sold separately) to the emitter of F3SG-SR or F3SG-PGA-A/L.
- 2.** When extending the cable length, connect a gray Extended Plug-Socket Cable for Emitter and/or Extended Socket-Straight Cable for Emitter (F39-JG□□-L, sold separately) to the emitter-side Root-Plug Cable for Extended.
- 3.** Connect a black Root-Straight Cable for Receiver (F39-JG□C-D, sold separately) or Root-Plug Cable for Extended for Receiver (F39-JGR3K-D, sold separately) to the receiver of F3SG-SR or F3SG-PGA-A/L or the emitter/receiver of F3SG-PGA-C.

- When extending the cable length, connect a black Extended Plug-Socket Cable for Receiver and/or Extended Socket-Straight Cable for Receiver (F39-JG□□-D, sold separately) to the receiver-side Root-Plug Cable for Extended.

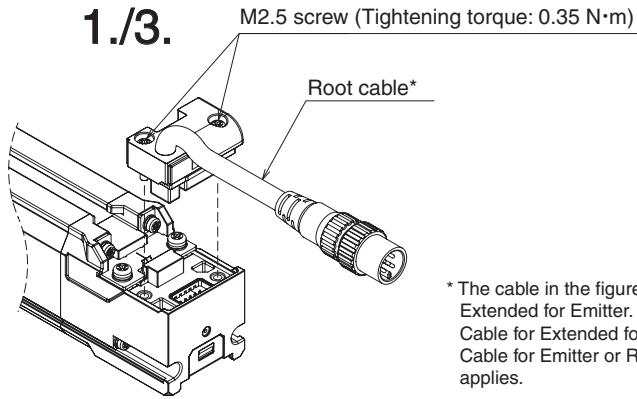

* The cable in the figure is a Root-Plug Cable for Extended for Emitter. For connecting a Root-Plug Cable for Extended for Receiver and Root-Straight Cable for Emitter or Receiver, the same method applies.

Marking on the side (Emitter)

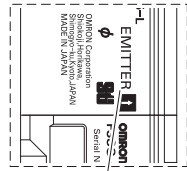

"EMITTER" mark

Marking on the side (Receiver)

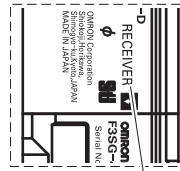

"RECEIVER" mark

Root-Plug Cable for Extended for Emitter
F39-JGR3K-L



Root-Plug Cable for Extended for Receiver
F39-JGR3K-D



Extended Plug-Socket Cable for Emitter
F39-JG□B-L

2.



Extended Plug-Socket Cable for Receiver
F39-JG□B-D

4.



- No wiring is needed for the passive mirror of F3SG-PGA-C.
- Connect the cable for the receiver with the emitter/receiver.
- For F3SG-SR-K, use the open-ended type.

5-4-3-1. Root-Straight Cable

■ Root-Straight Cable for Emitter (F39-JG□C-L, sold separately)

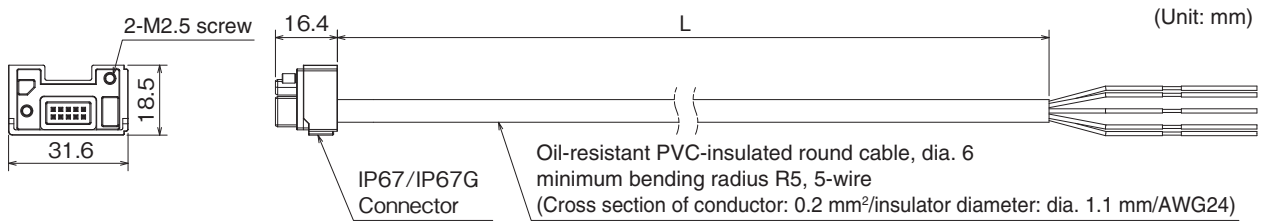

<Internal wiring diagram>

Brown	24V/0V
Black	TEST
Blue	0V/24V
White	COM(+)
Yellow	OPERATING RANGE SELECT INPUT/COM(-)

■ Root-Straight Cable for Receiver (F39-JG□C-D, sold separately)

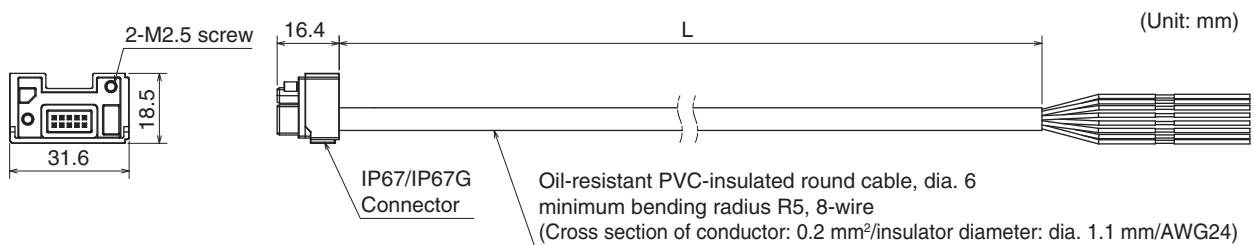

<Internal wiring diagram>

Yellow	RESET/EDM
Brown	24V/0V
Gray	MUTE A/PRE-RESET/PSDI/COM(+)
Pink	MUTE B/COM(-)
Black	OSSD 1
White	OSSD 2
Blue	0V/24V
Red	AUX

Emitter cable (Gray)	Receiver cable (Black)	Length (L)
F39-JG3C-L	F39-JG3C-D	3 m
F39-JG7C-L	F39-JG7C-D	7 m
F39-JG10C-L	F39-JG10C-D	10 m

5-4-3-2. Root-Plug Cable for Extended

■ Root-Plug Cable for Extended for Emitter (F39-JGR□K-L, sold separately)

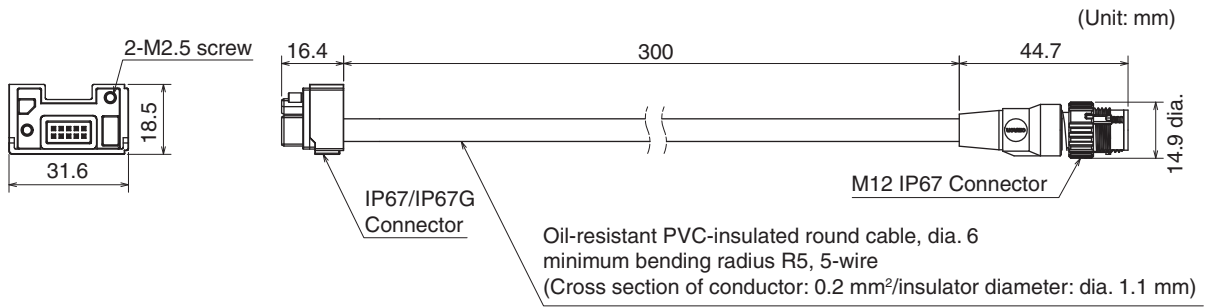

<Internal wiring diagram>

1	Brown	24V/0V
2	Black	TEST
3	Blue	0V/24V
4	White	COM(+)
5	Yellow	OPERATING RANGE SELECT INPUT/COM(-)



■ Root-Plug Cable for Extended for Receiver (F39-JGR□K-D, sold separately)

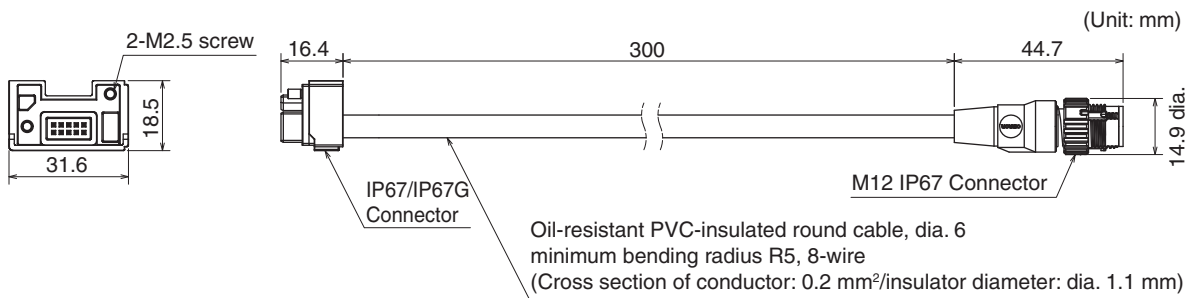

<Internal wiring diagram>

1	Yellow	RESET/EDM
2	Brown	24V/0V
3	Gray	MUTE A/PRE-RESET/PSDI/COM(+)
4	Pink	MUTE B/COM(-)
5	Black	OSSD 1
6	White	OSSD 2
7	Blue	0V/24V
8	Red	AUX



Emitter cable (Gray)	Receiver cable (Black)	Length
F39-JGR3K-L	F39-JGR3K-D	0.3 m

5-4-3-3. Extended Socket-Straight Cable

Extended Socket-Straight Cable for Emitter (F39-JG□A-L, sold separately)

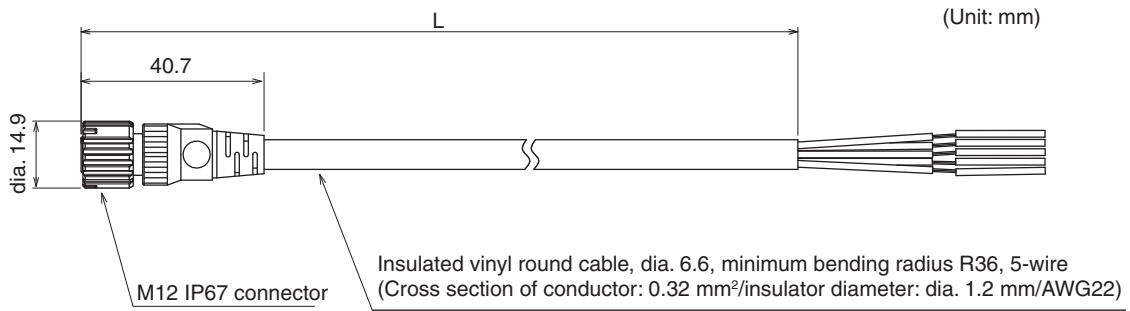

<Internal wiring diagram>

Connected to root cable or
Extended Plug-Socket Cable

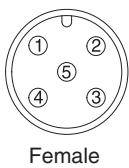

1	Brown	24V/0V
2	Black	TEST
3	Blue	0V/24V
4	White	COM(+)
5	Yellow	OPERATING RANGE SELECT INPUT/COM(-)

Extended Socket-Straight Cable for Receiver (F39-JG□A-D, sold separately)

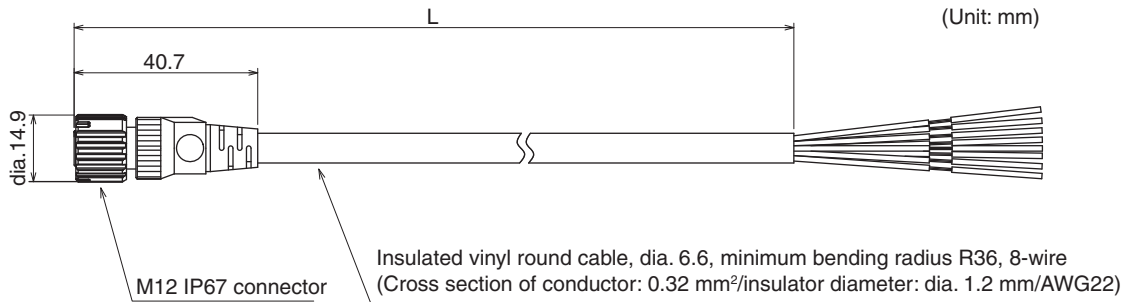

<Internal wiring diagram>

Connected to root cable or
Extended Plug-Socket Cable

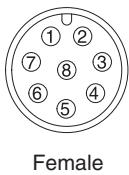

1	Yellow	RESET/EDM
2	Brown	24V/0V
3	Gray	MUTE A/PRE-RESET/PSDI/COM(+)
4	Pink	MUTE B/COM(-)
5	Black	OSSD 1
6	White	OSSD 2
7	Blue	0V/24V
8	Red	AUX

Emitter cable (Gray)	Receiver cable (Black)	Length (L)
F39-JG3A-L	F39-JG3A-D	3 m
F39-JG7A-L	F39-JG7A-D	7 m
F39-JG10A-L	F39-JG10A-D	10 m
F39-JG15A-L	F39-JG15A-D	15 m
F39-JG20A-L	F39-JG20A-D	20 m

5-4-3-4. Extended Plug-Socket Cable

- Extended Plug-Socket Cable for Emitter: Cable for extension (F39-JG□B-L, sold separately)

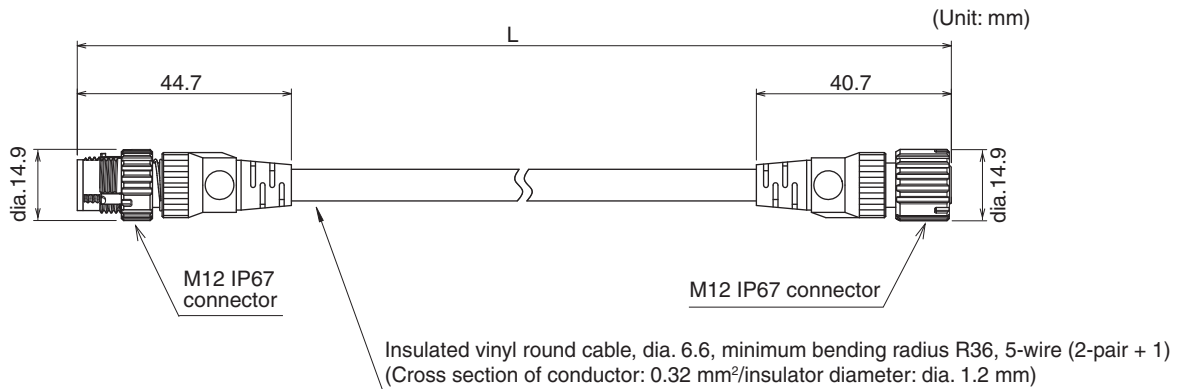

<Internal wiring diagram>

Connected to root cable or
Extended Plug-Socket Cable

Connected to Extended Socket-Straight
Cable or Extended Plug-Socket Cable

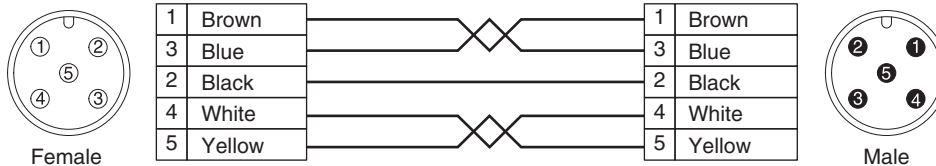

Twisted pair wires are brown and blue, and white and yellow.

- Extended Plug-Socket Cable for Receiver: Cable for extension (F39-JG□B-D, sold separately)

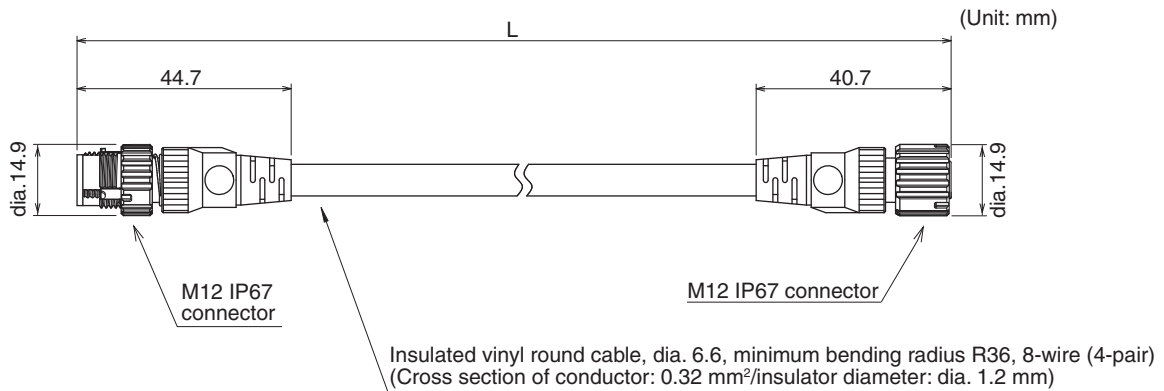

<Internal wiring diagram>

Connected to root cable or
Extended Plug-Socket Cable

Connected to Extended Socket-Straight
Cable or Extended Plug-Socket Cable

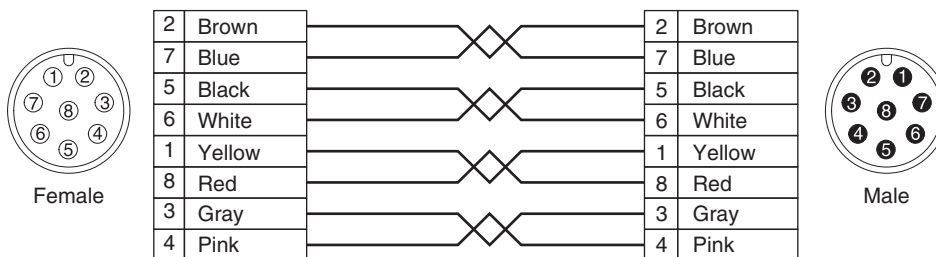

Twisted pair wires are brown and blue, black and white, yellow and red, and gray and pink.

Emitter cable (Gray)	Receiver cable (Black)	Length (L)
F39-JGR5B-L	F39-JGR5B-D	0.5 m
F39-JG1B-L	F39-JG1B-D	1 m
F39-JG3B-L	F39-JG3B-D	3 m
F39-JG5B-L	F39-JG5B-D	5 m
F39-JG7B-L	F39-JG7B-D	7 m
F39-JG10B-L	F39-JG10B-D	10 m
F39-JG15B-L	F39-JG15B-D	15 m
F39-JG20B-L	F39-JG20B-D	20 m

If the length of the F39-JG□A Single-Ended Cable is insufficient, use 1 or more F39-JG□B Extended Plug-Socket Cables to extend the length, as required. The total cable extension length of the root cable must be 100 m max. (When the Intelligent Tap (F39-SGIT-IL3) is connected to the sensor, this applies in the case of the rated power supply of 24 VDC or higher.)

<Connection example>

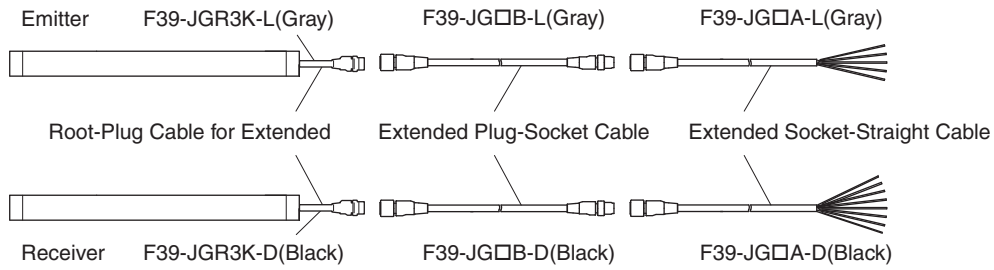

5-4-3-5. Cascading Cable for Extended

- Cascading Cable for Extended (F39-JGR3W, sold separately) (two cables per set, one for emitter and one for receiver)
- Emitter Cascading Cable for Extended

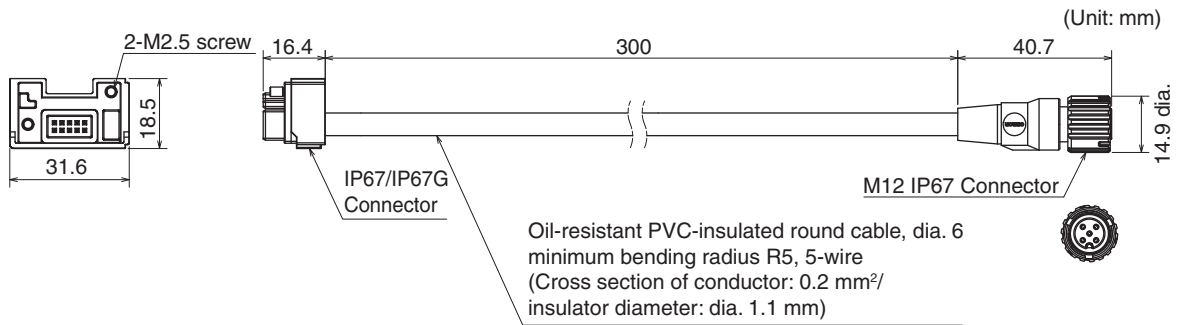

- Receiver Cascading Cable for Extended

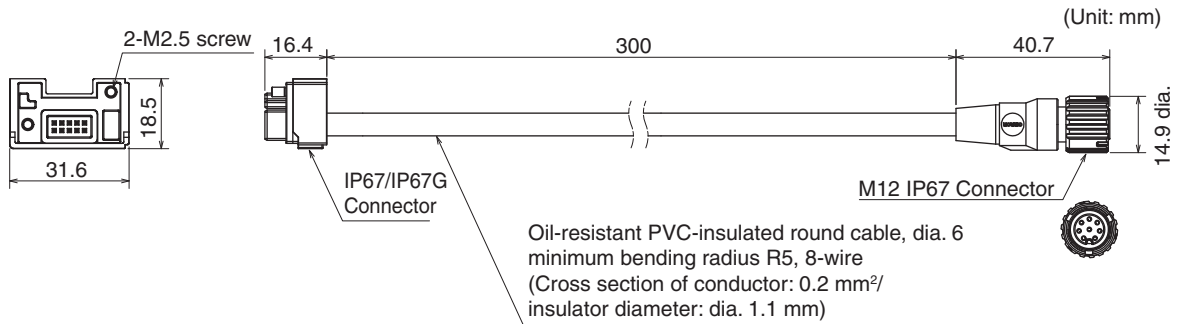

Set model name	Emitter cable (Gray)	Receiver cable (Black)	Length
F39-JGR3W	F39-JGR3W-L	F39-JGR3W-D	0.3 m

If the length of the cascading cable is insufficient, connect the F39-JG□B-□ Extended Plug-Socket Cable (sold separately) between the cascading cable and the F39-JGR3K root cable of the secondary sensor, as required. (Extension cable between sensors: 10 m max. (not including Cascading Cable for Extended*1 and Root Cable*2.))

*1. F39-JGR3W

*2. F39-JGR3K

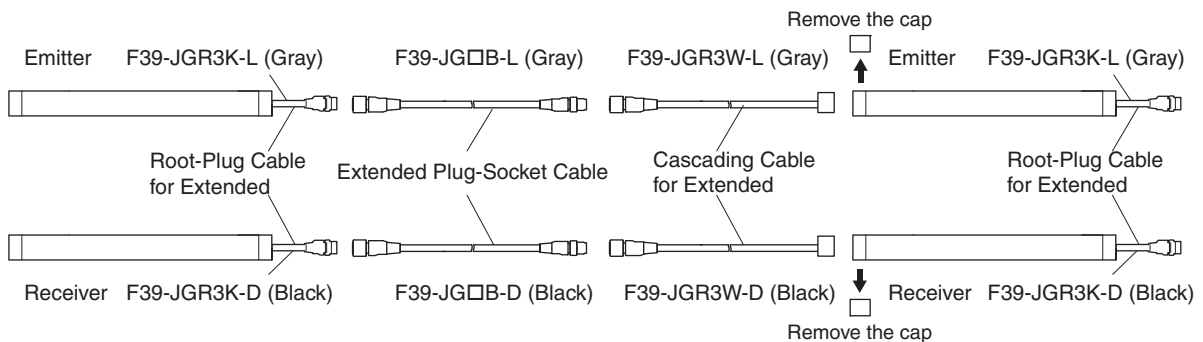

5-4-3-6. Side-by-side Cascading Cable

- Side-by-side Cascading Cable (F39-JGR12L , sold separately) (two cables per set, one for emitter and one for receiver)
- Side-by-side Cascading Cable for Emitter

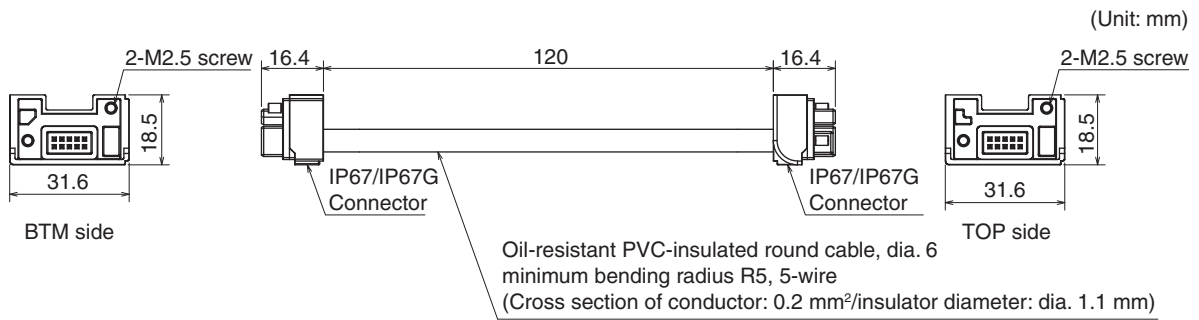

- Side-by-side Cascading Cable for Receiver

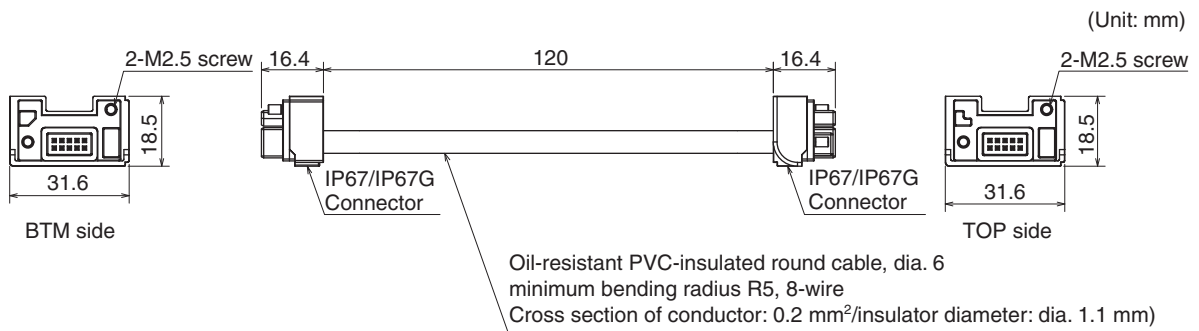

Set model name	Emitter cable (Gray)	Receiver cable (Black)	Length
F39-JGR12L	F39-JGR12L-L	F39-JGR12L-D	12 cm

To extend the cable length to more than 12 cm, add the F39-JGR3W Cascading Cable for Extended.

5-4-3-7. F3SJ-A/B Conversion Cable

Used to convert the wiring for F3SJ-A/B, F3SR-B or F3SN Safety Light Curtain to that for the F3SG-SR.



Do not connect the Conversion Cable for the following purposes. Failure to do so may result in failure.

1. Connecting with the F39-SGIT-IL3, F39-GCNY2 or F39-GCNY3
2. Connecting between the F3SG-SR's



Conversion Cables are only for PNP connection. To use for NPN, connect the 24 VDC line and the 0 VDC line in reverse.



There are the restrictions on the functions related to wiring when using Conversion Cables.

■ F3SJ-A/B Conversion Cable for Emitter (F39-JGR3K-SJ-L, sold separately)

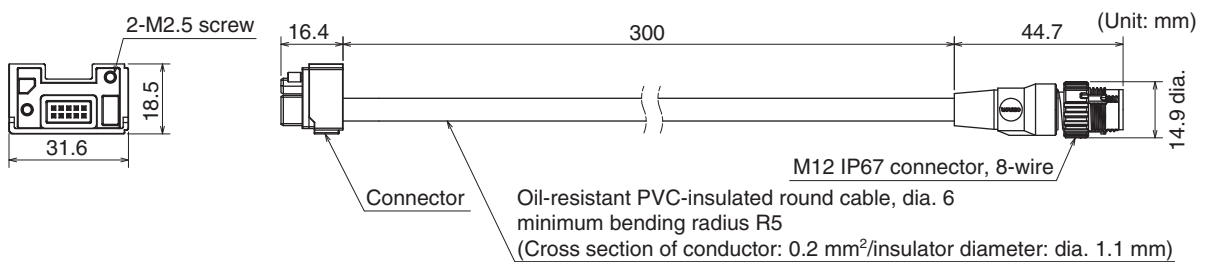

<Internal wiring diagram>

Connected to connector of F3SJ-A/B, F3SR-B or F3SN emitter cable

	F3SJ-A/B	F3SR-B	F3SN
1	Not used	Not used	Not used
2	+24 VDC	+24 VDC	+24 VDC
3	Test input	Test input	Test input
4	Not used	Not used	Not used
5	Communication line (+)	Communication line (+)	RS-485(A)
6	Communication line (-)	Communication line (-)	RS-485(B)
7	0 VDC	0 VDC	0 VDC
8	Not used	Not used	Not used



■ F3SJ-A/B Conversion Cable for Receiver (F39-JGR3K-SJ-D, sold separately)

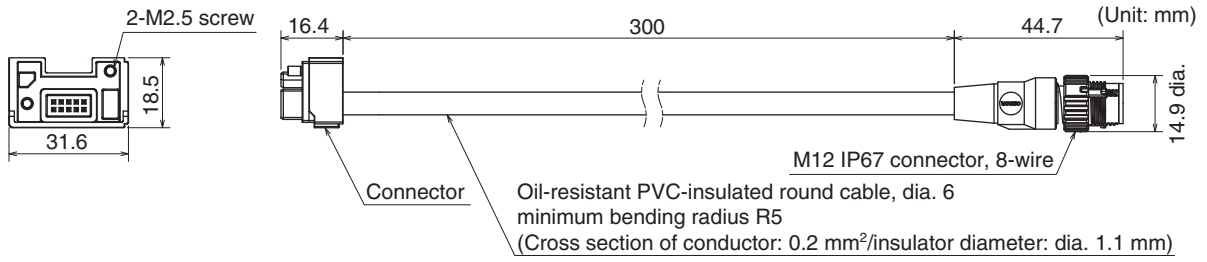

<Internal wiring diagram>

Connected to connector of F3SJ-A/B, F3SR-B or F3SN receiver cable

	F3SJ-A/B	F3SR-B	F3SN
1	Safety output 2	Safety output 2	OSSD2
2	+24 VDC	+24 VDC	+24 VDC
3	Safety output 1	Safety output 1	OSSD1
4	Auxiliary output 1	Operating range select input	Auxiliary output
5	Communication line (+)	Communication line (+)	RS-485(A)
6	Communication line (-)	Communication line (-)	RS-485(B)
7	0 VDC	0 VDC	0 VDC
8	External device monitoring input	External device monitoring input	EDM input



Emitter cable (Gray)	Receiver cable (Black)	Length
F39-JGR3K-SJ-L	F39-JGR3K-SJ-D	0.3 m

5-4-3-8. F3SG-RE Conversion Cable

Used to convert the wiring for F3SG-RE Safety Light Curtain to that for the F3SG-SR.



Do not connect the Conversion Cable for the following purposes. Failure to do so may result in failure.

1. Connecting with the F39-SGIT-IL3, F39-GCNY2 or F39-GCNY3
2. Connecting between the F3SG-SR's



Conversion Cables are only for PNP connection. To use for NPN, connect the 24 VDC line and the 0 VDC line in reverse.



There are the restrictions on the functions related to wiring when using Conversion Cables.

■ F3SG-RE Conversion Cable for Emitter (F39-JGR3K-RE-L, sold separately)

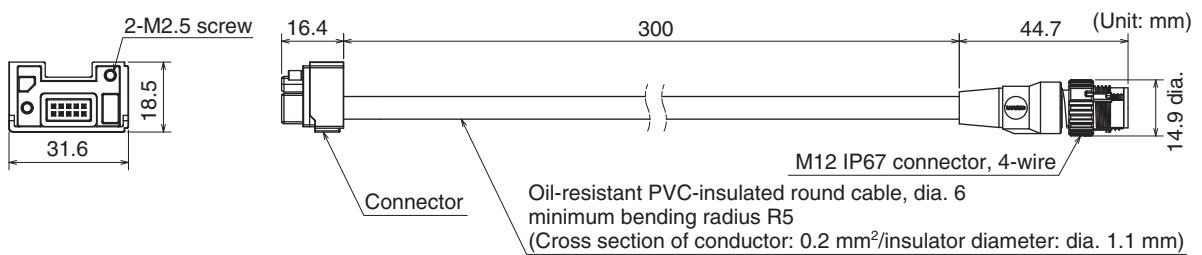

<Internal wiring diagram>

Connected to connector of F3SG-RE emitter cable

F3SG-RE	
1	+24 VDC
2	Operating Range Select Input
3	0 VDC
4	Not used



■ F3SG-RE Conversion Cable for Receiver (F39-JGR3K-RE-D, sold separately)

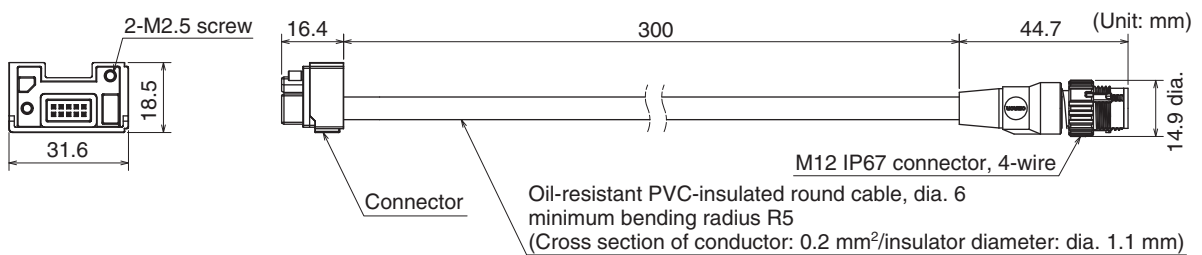

<Internal wiring diagram>

Connected to connector of F3SG-RE receiver cable

F3SG-RE	
1	+24 VDC
2	OSSD 2
3	0 VDC
4	OSSD 1



Emitter cable (Gray)	Receiver cable (Black)	Length
F39-JGR3K-RE-L	F39-JGR3K-RE-D	0.3 m

5-4-3-9. MS48 Conversion Cable

Used to convert the wiring for MS4800 Safety Light Curtain to that for the F3SG-SR.



Do not connect the Conversion Cable for the following purposes. Failure to do so may result in failure.

1. Connecting with the F39-SGIT-IL3, F39-GCNY2 or F39-GCNY3
2. Connecting between the F3SG-SR's



Conversion Cables are only for PNP connection. To use for NPN, connect the 24 VDC line and the 0 VDC line in reverse.



There are the restrictions on the functions related to wiring when using Conversion Cables.

■ MS48 Conversion Cable for Emitter (F39-JGR3K-MS-L, sold separately)

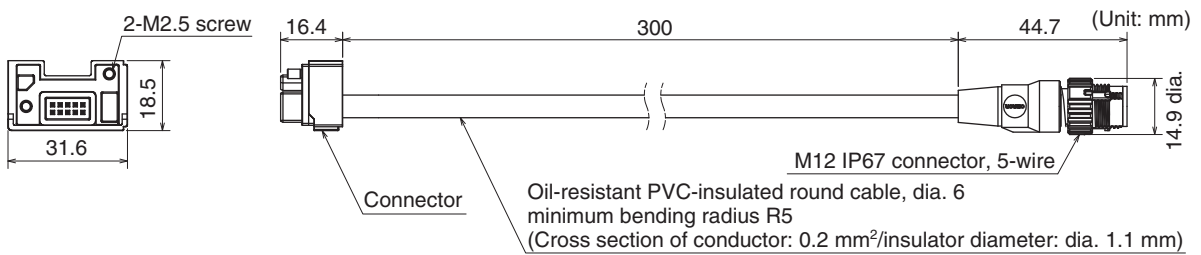

<Internal wiring diagram>

Connected to connector of MS4800 transmitter cable

MS4800	
1	0 VDC
2	+24 VDC
3	Not used
4	Not used
5	Not used



■ MS48 Conversion Cable for Receiver (F39-JGR3K-MS-D, sold separately)

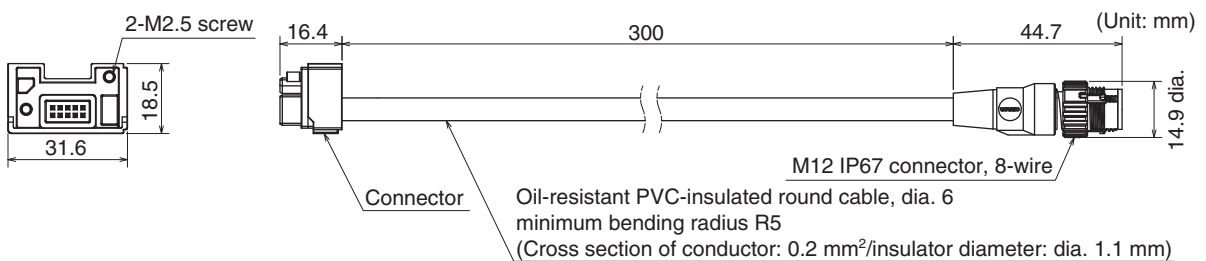

<Internal wiring diagram>

Connected to connector of MS4800 receiver cable

MS4800	
1	+24 VDC
2	0 VDC
3	Not used
4	OSSD 2
5	Start or EDM (Mode Select)
6	EDM
7	Auxiliary Out
8	OSSD 1



Emitter cable (Gray)	Receiver cable (Black)	Length
F39-JGR3K-MS-L	F39-JGR3K-MS-D	0.3 m

5-4-3-10. F3SJ-A/B-TS/T, F3SG-RA-TS Conversion Cable

Used to convert the wiring for F3SJ-A/B-TS/T or F3SG-RA-TS Safety Light Curtain to that for the F3SG-SR.



CHECK!

- Do not connect the Conversion Cable for the following purposes. Failure to do so may result in failure.
1. Connecting with the F39-SGIT-IL3, F39-GCNY2 or F39-GCNY3
 2. Connecting between the F3SG-SR's



CHECK!

Conversion Cables are only for PNP connection. To use for NPN, connect the 24 VDC line and the 0 VDC line in reverse.



CHECK!

There are the restrictions on the functions related to wiring when using Conversion Cables.

■ F3SJ-A/B-TS/T, F3SG-RA-TS Conversion Cable for Emitter (F39-JGR3K-SW-L, sold separately)

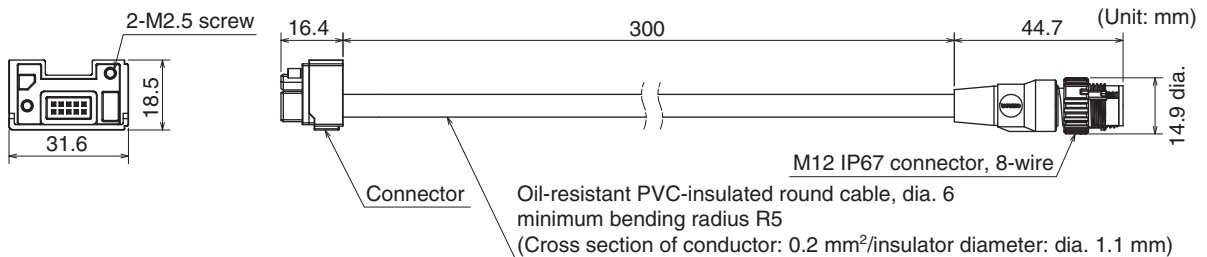

<Internal wiring diagram>

Connected to connector of F3SJ-A/B-TS/T or F3SG-RA-TS emitter cable

	F3SJ-A/B-TS/T	F3SG-RA-TS
1	Not used	Not used
2	+24 VDC	+24 VDC
3	Not used	Not used
4	Not used	Not used
5	Communication line (+)	Communication line (+)
6	Communication line (-)	Communication line (-)
7	0 VDC	0 VDC
8	Not used	Not used



Male

■ F3SJ-A/B-TS/T, F3SG-RA-TS Conversion Cable for Receiver
(F39-JGR3K-SJ-D, sold separately)

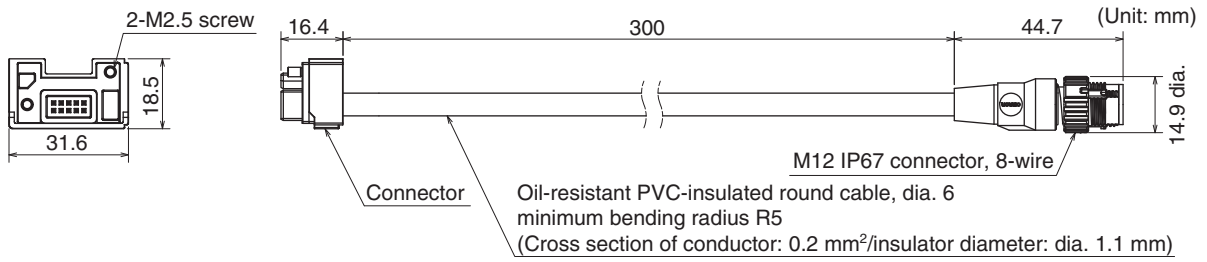

<Internal wiring diagram>

Connected to connector of F3SJ-A/B-TS/T or F3SG-RA-TS receiver cable

	F3SJ-A/B-TS/T	F3SG-RA-TS
1	Safety output 2	Safety output 2
2	+24 VDC	+24 VDC
3	Safety output 1	Safety output 1
4	Auxiliary output 1	Operating range select input
5	Communication line (+)	Communication line (+)
6	Communication line (-)	Communication line (-)
7	0 VDC	0 VDC
8	External device monitoring input	External device monitoring input



Emitter cable (Gray)	Receiver cable (Black)	Length
F39-JGR3K-SW-L	F39-JGR3K-SJ-D	0.3 m

5-4-3-11. Extending Cable Length with Commercially Available Cable

When you need to use a cable that is not specified by OMRON, use a cable that satisfies the following specifications.

1. Emitter: 5-wire Receiver: 8-wire
2. 0.2 mm² or larger, conductor resistance 0.058 ohms/m max.
3. Mute A and Mute B lines, and 24V/0V and 0V/24V lines must be used as twisted-pair lines.

When using, for the Intelligent Tap, cables with a connector other than a straight type such as the L-shaped, the cables may interfere with another cable or device or a mounting surface. Take notches or shapes of the connectors into account in installing them.

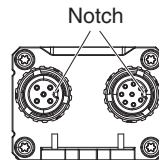

Do not use cables in the same conduit as high voltage or electric power lines.

CHECK!

5-4-3-12. Reduced Wiring Connector System with Y-Joint Plug/Socket Connector

Reduced wiring can be achieved by using a Y-Joint Plug/Socket Connector (F39-GCNY2, sold separately).



CHECK!

When using the Y-Joint Plug/Socket Connector, the External Test, Operating Range Selection and Wired Synchronization cannot be used.

■ Y-Joint Plug/Socket Connector (F39-GCNY2, sold separately)

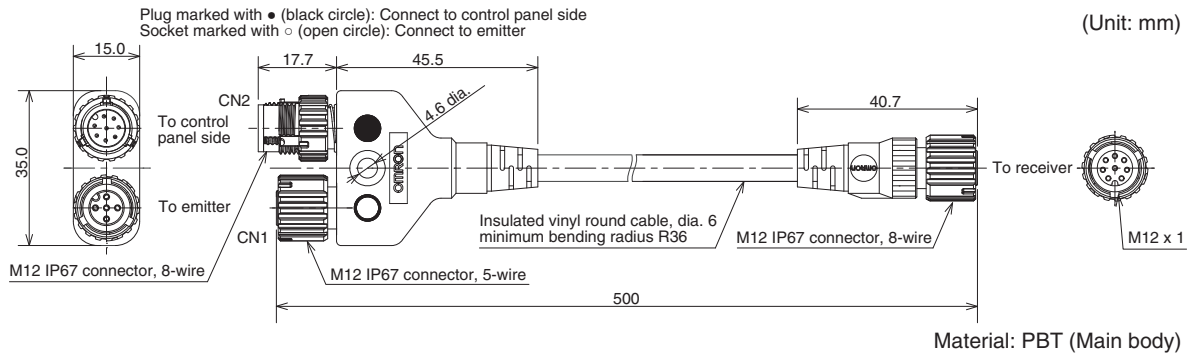

<Internal wiring diagram>

Connected to Extended Socket-Straight Cable or Extended Plug-Socket Cable of receiver

Connected to root cable or Extended Plug-Socket Cable of receiver

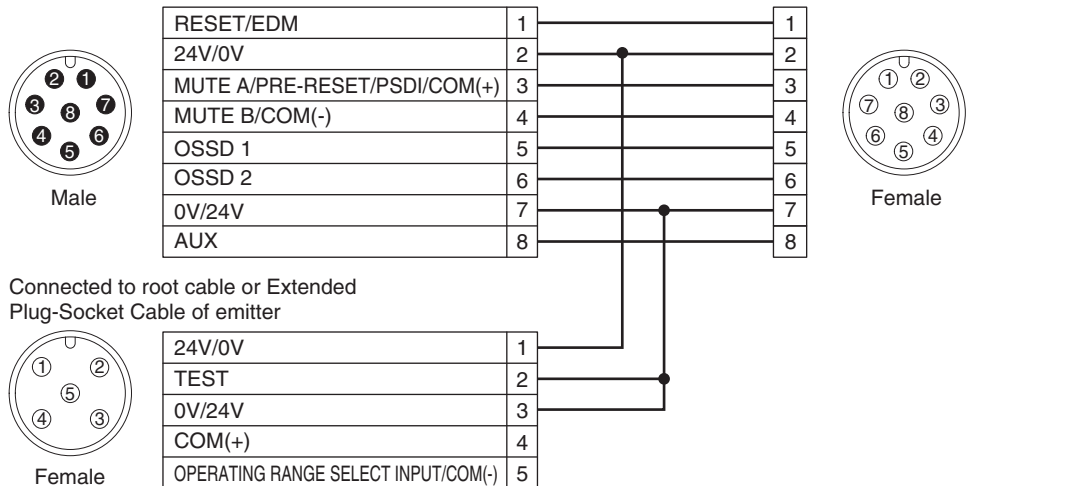

Model	Length
F39-GCNY2	0.5 m

5-4-3-13. Easy Wiring Connector System with Reset Switch Connector

When arranging reset switch near F3SG-SR/PG, easy wiring can be achieved by using a Reset Switch Connector (F39-GCNY3, sold separately).



When using the Reset Switch Connector, the External Device Monitoring (EDM) cannot be used.

Reset Switch Connector (F39-GCNY3, sold separately)

Plug marked with ● (black circle): Connect to control panel side
 Plug marked with ○ (open circle): Connect to reset switch side

(Unit: mm)

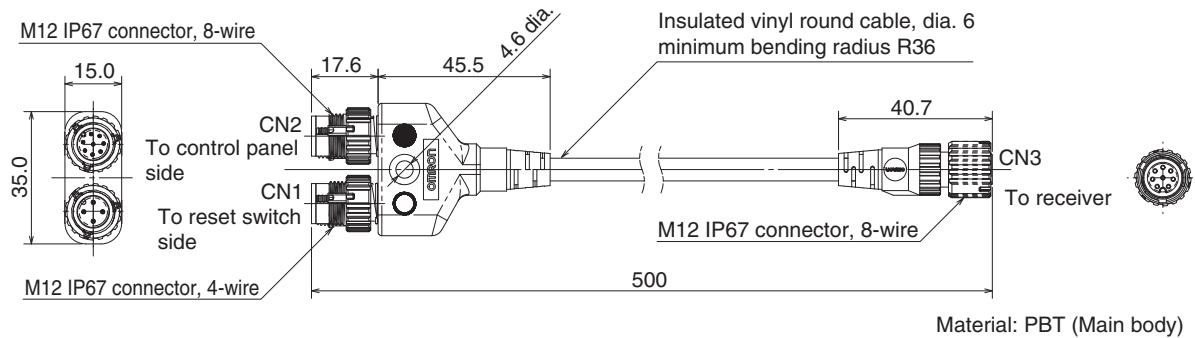

<Internal wiring diagram>

Connected to Extended Socket-Straight Cable or Extended Plug-Socket Cable of receiver

Connected to root cable or Extended Plug-Socket Cable of receiver

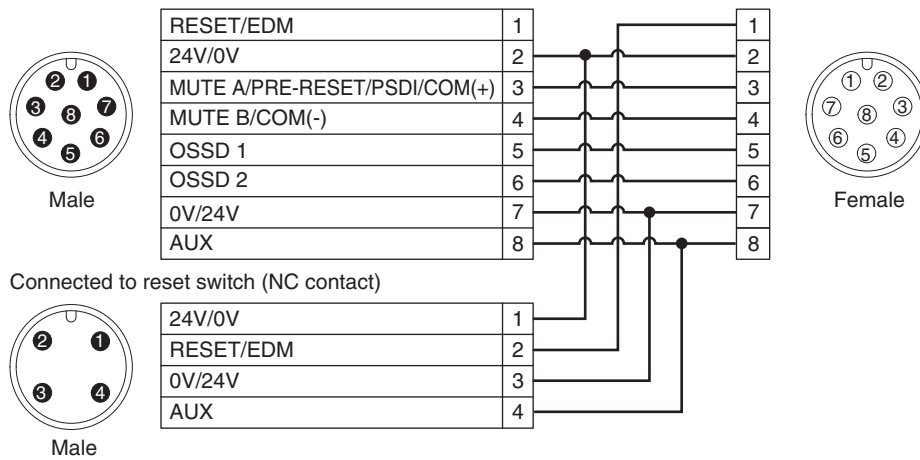

Model	Length
F39-GCNY3	0.5 m

■ Connector Connected to Cable, Socket on One Cable End (XS5F-D421-□80-F, sold separately)

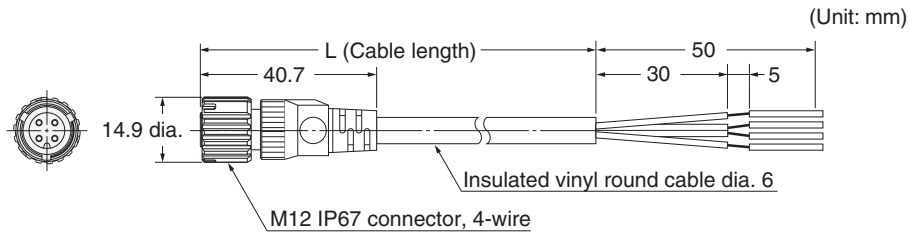

<Internal wiring diagram>

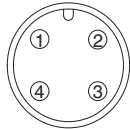

Female

1	Brown	24V/0V
2	White	RESET
3	Blue	0V/24V
4	Black	AUX

Model	Length
XS5F-D421-C80-F	1 m
XS5F-D421-D80-F	2 m
XS5F-D421-E80-F	3 m
XS5F-D421-G80-F	5 m
XS5F-D421-J80-F	10 m
XS5F-D421-L80-F	20 m

5-4-3-14. Reduced Wiring System with Muting Connector Box

Reduced wiring can be achieved by using a Muting Connector Box (F39-GCN5, sold separately).

■ Muting Connector Box (F39-GCN5, sold separately)

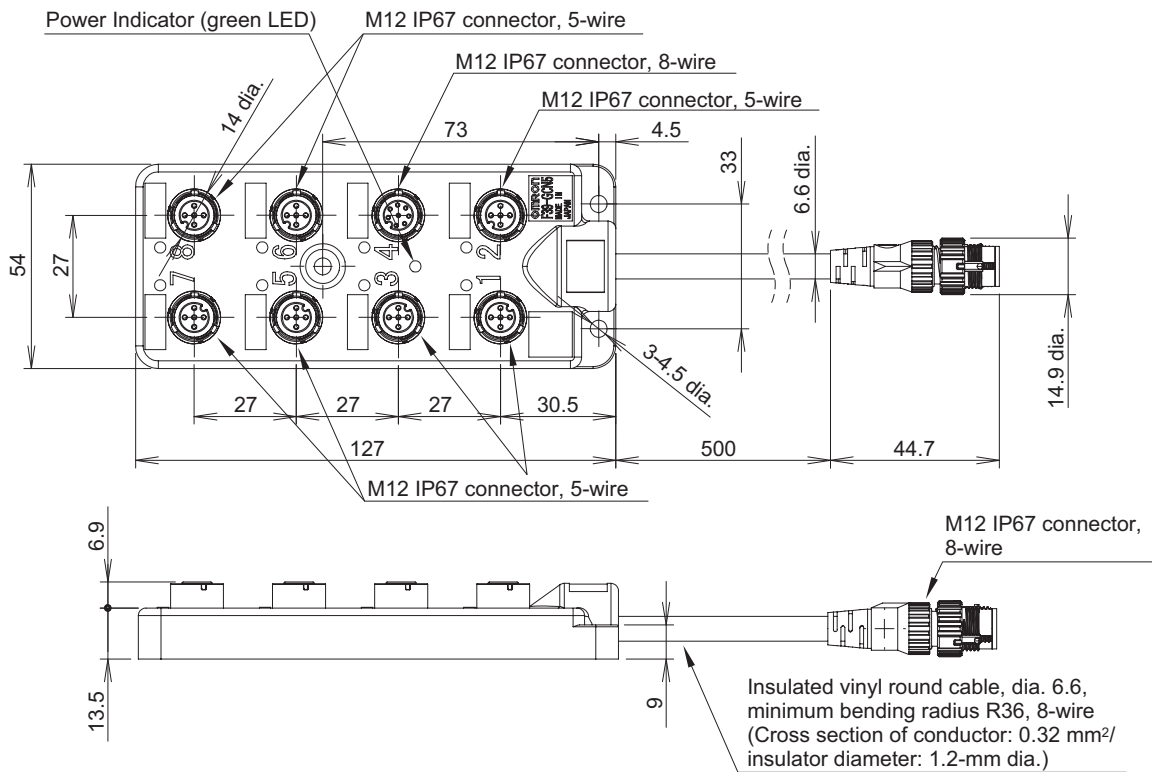

<Internal wiring diagram>

Connected to the extension cable for emitter (Extended Socket-Straight Cable or Extended Plug-Socket Cable)



1	24V/0V (connected with CN0's ②)
2	Auxiliary output (connected with CN0's ⑧)
3	0V/24V (connected with CN0's ⑦)
4	Test input
5	Not used

Connected to the extension cable for receiver (Extended Socket-Straight Cable or Extended Plug-Socket Cable)

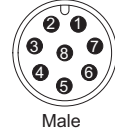

1	Connected with CN1's ①
2	24V/0V
3	Not used
4	Not used
5	OSSD1
6	OSSD2
7	0V/24V
8	Auxiliary output

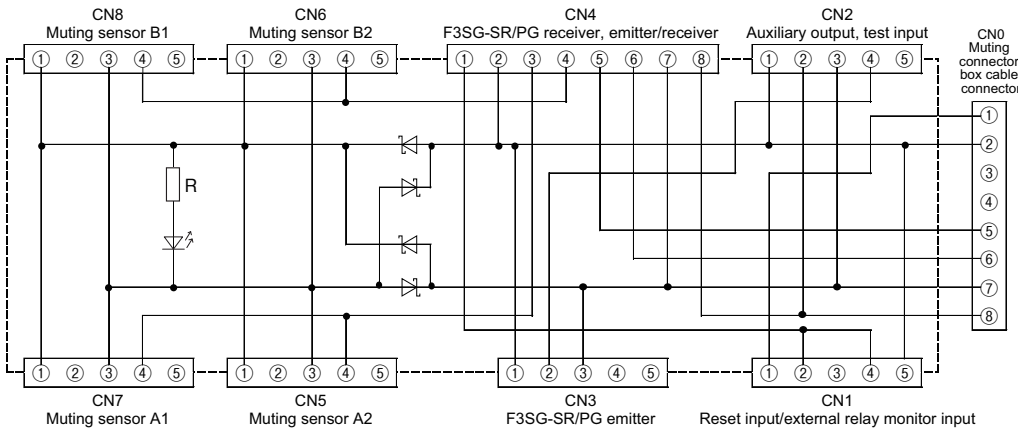

Connected to the extension cable for emitter (Extended Socket-Straight Cable or Extended Plug-Socket Cable)



1	Connected with CN0's ①
2	Reset input/external relay monitor input *1
3	Not used
4	Reset input/external relay monitor input *1
5	24V/0V (connected with CN0's ②)

*1. One input is usable as the reset input/external relay monitor input and the other input as the override cancel input.

<Wiring example: EDM enabled>

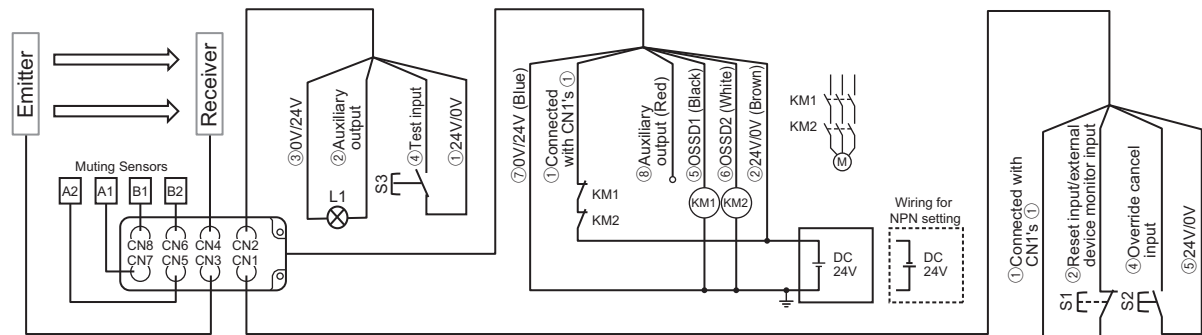

S1: Lock out/interlock reset/override switch
 S2: Override cancel switch
 S3: Test switch
 KM1, KM2: External relay
 L1: Lamp

Model	Length
F39-GCN5	0.5 m

5-4-3-15. Wiring of IP69K Model

No dedicated cable is used for F3SG-SR-K. To extend the cable, use a cable satisfying the specification below.

1. Emitter: 5-wire, receiver: 8-wire
2. 0.2mm² or larger, conductor resistance 0.058 ohms/m max.



Do not use cables in the same conduit as high voltage or electric power lines.

<Emitter>

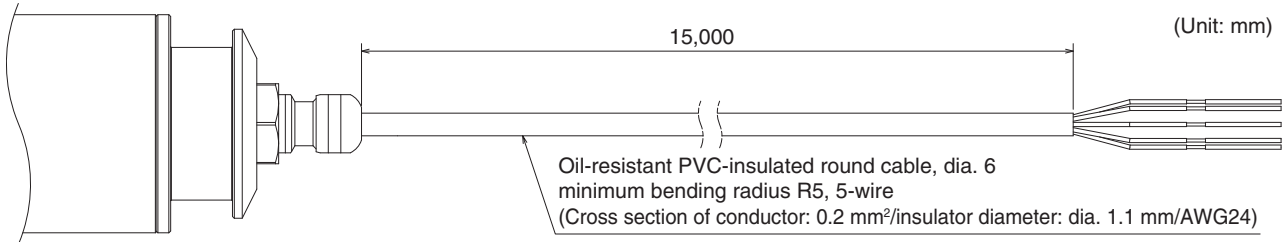

Brown	24V/0V
Black	TEST
Blue	0V/24V
White	COM(+)
Yellow	OPERATING RANGE SELECT INPUT/COM(-)

<Receiver>

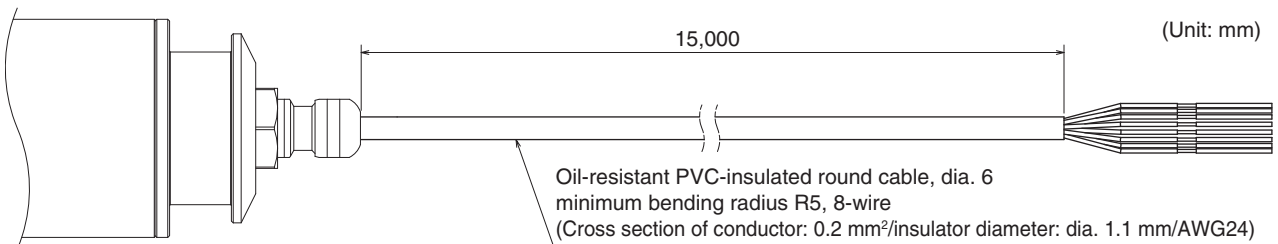

Yellow	RESET/EDM
Brown	24V/0V
Gray	MUTE A/PRE-RESET/PSDI/COM(+)
Pink	MUTE B/COM(-)
Black	OSSD 1
White	OSSD 2
Blue	0V/24V
Red	AUX

5-4-3-16. Intelligent Tap-to-IO-Link Master Cable

- Intelligent Tap-to-IO-Link Master Cable (Single ended cable)
(XS5F-D521-DJ0-IL, sold separately)

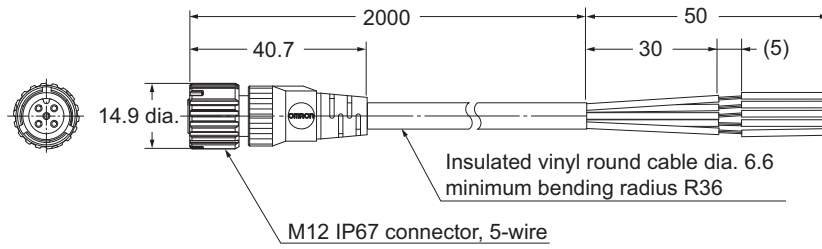

<Internal wiring diagram>

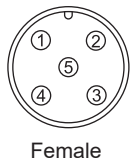

1	Brown	L+
2	White	DO
3	Blue	L-
4	Black	C/Q
5	Yellow	Not used

Model	Length
XS5F-D521-DJ0-IL	2 m

5-4-4. Functional Earth Connection

The F3SG-SR/PG operates properly without functional earth connection in a general industrial environment. If the F3SG-SR/PG fails due to electrical noise, connecting the F3SG-SR/PG to the functional earth may work to prevent the noise. It is recommended the functional earth terminal of the F3SG-SR/PG be connected to functional earth cables. Connection with protective earth cables may cause the F3SG-SR/PG to fail due to a noise level of the environment.

When you connect the F3SG-SR/PG with the functional earth, connect an earth cable to the functional earth terminals, as shown below.

The size of the screws of the terminals is M3. Make sure to use crimp terminals that fits the size.

The earth cable must have a cross section of 1 mm² or more with conductor resistance of 0.058 ohms/m or less and a length of 20 m or less.

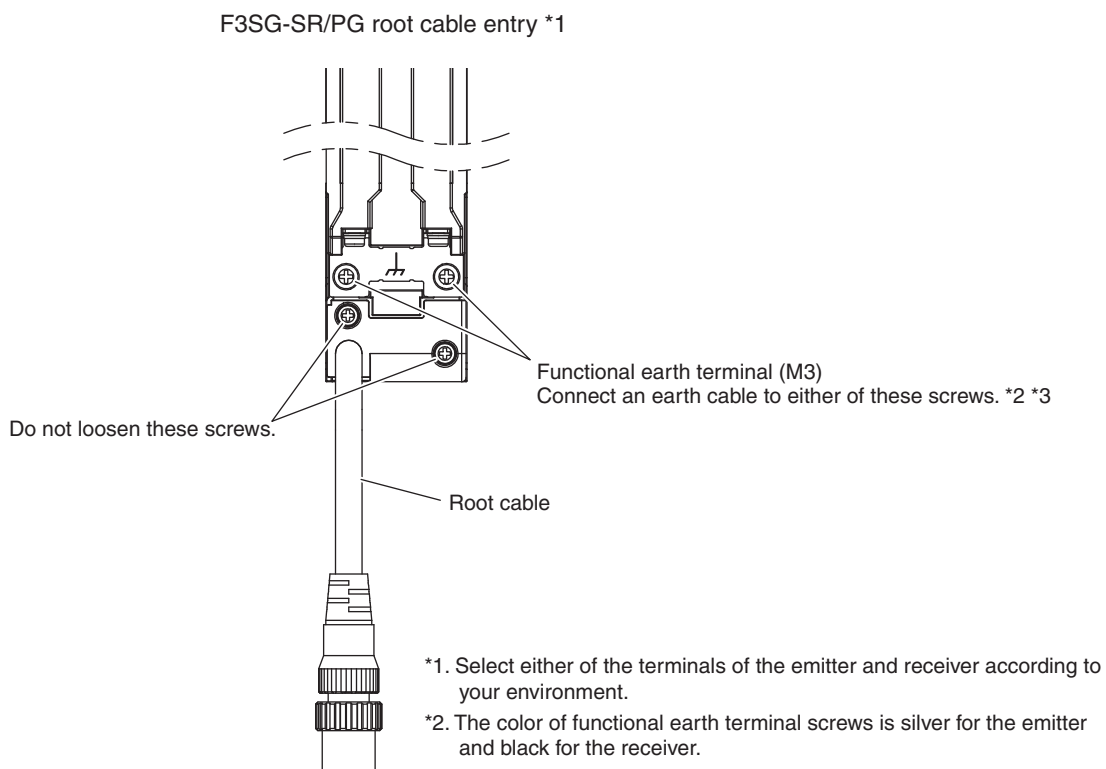

5-5. Cascade Connection

F3SG-SRA	Yes
F3SG-SRB	Yes
F3SG-PG	No
F3SG-SR-K	No

5-5-1. Overview

Up to 3 sets of F3SG-SR can be series-connected. Cascade connection allows them to be used as a safety light curtain, requiring only 1 set to be wired to a controller and preventing mutual interference. If any 1 set of series-connected F3SG-SR is blocked, both of the safety outputs turn OFF.

- Number of connections: Up to 3 sets
- Total number of beams: Up to 255 beams
- Response time: Varies according to the number of beams of cascaded F3SG-SR segments.



CHECK!

Combination of different models (Type2 and Type4 or SRA and SRB) are not allowed.



1-6-3. Calculation of Response Time of Cascaded Segments

- Cable length between sensors: 10 m max. (not including cascading cable (F39-JGR3W) and root cable (F39-JGR3K or F39-JG□C))

Example: Configuring an U-shaped detection zone

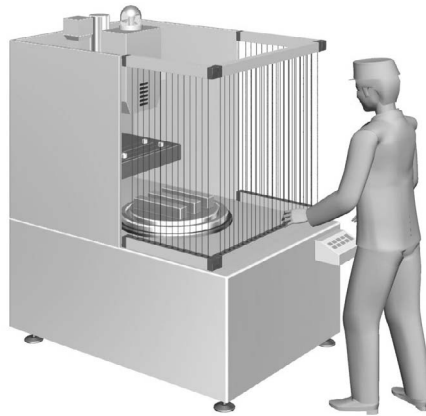

The sensor segments in a cascade connection are called as follows:

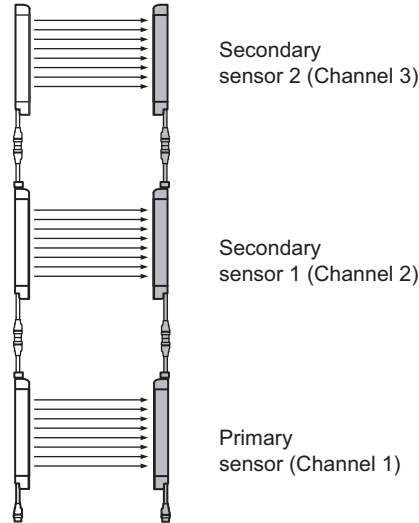

Properly connect an emitter to another emitter, and a receiver to another receiver, as shown below.

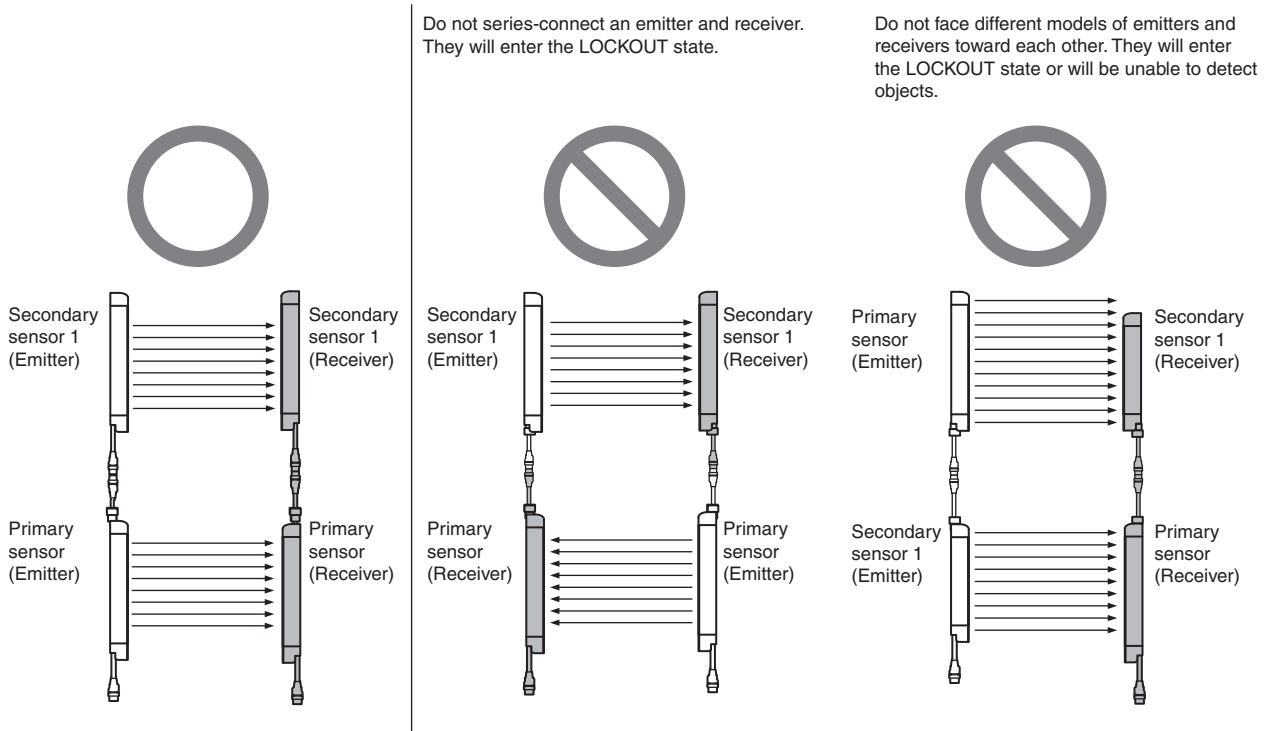

 If caps and Cascading Cables are not connected properly, the F3SG-SR enters lockout (when power is turned ON).
CHECK!

5-5-2. Connection Procedure

■ When Using the F39-JGR3W Cascading Cable for Extended (sold separately)

1. Remove the caps from the primary sensor. Loosen the screw (M2.5 cross-head) to remove the cap.
2. Connect the primary sensor and the secondary sensor with the F39-JGR3W Cascading Cable (sold separately).
3. If the length of the cascading cable is insufficient, connect the F39-JG□B-□ Extended Plug-Socket Cable (sold separately) between the cascading cable and the F39-JGR3K root cable of the secondary sensor, as required. (Cable length between sensors: 10 m max. (not including cascading cable (F39-JGR3W) and root cable (F39-JGR3K or F39-JG□C).)

Do not connect the F3SG-SR upside down. In the figure below, the side with the mark "BTM" on the plastic part of the F3SG-SR must come to the down side.

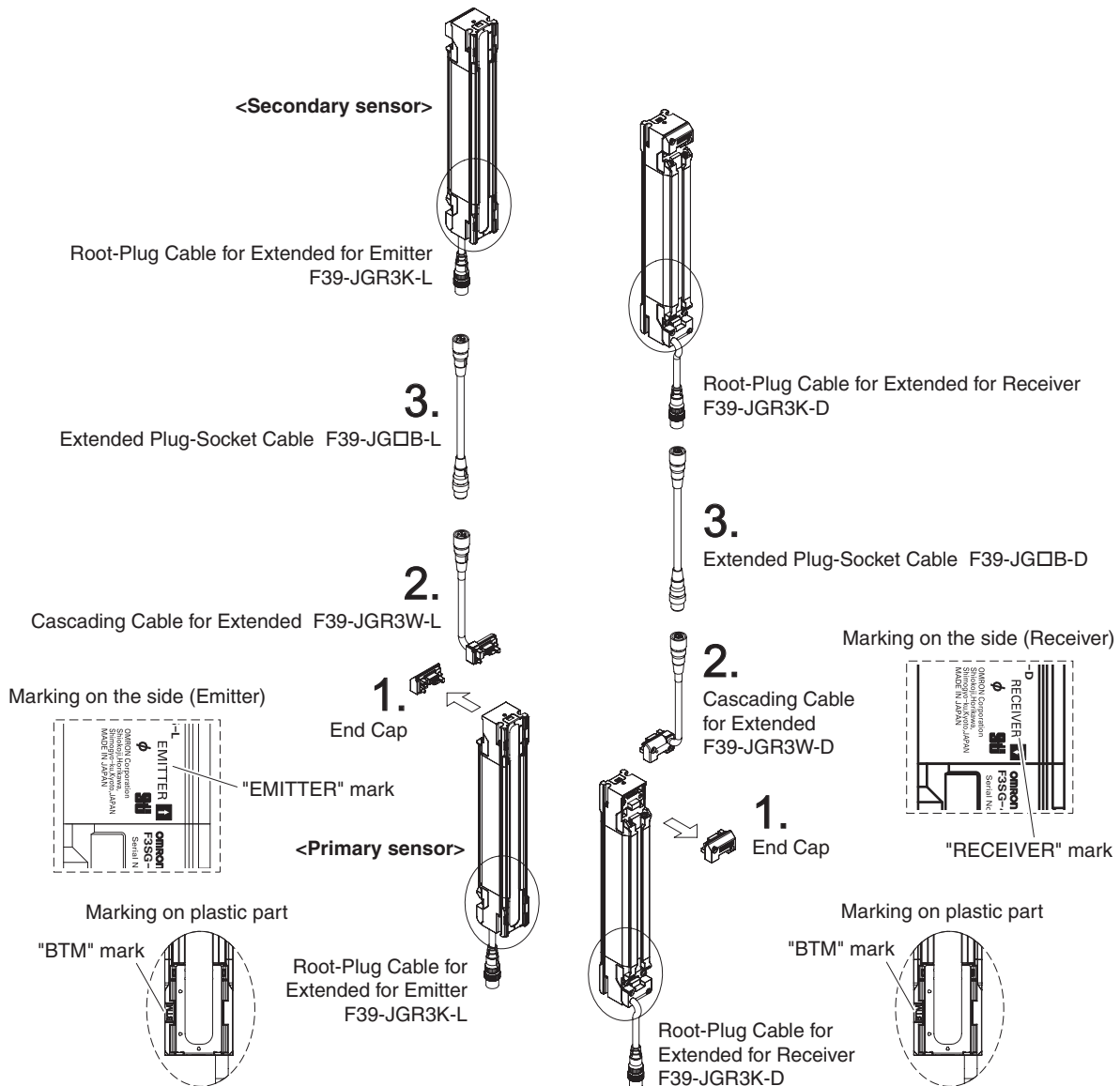

- When attaching a cable or cap, securely fasten the screws (M2.5, recommended torque: 0.35 N·m). Failure to do so may cause the cable/cap to come loose, leading to deterioration of the protective functions.
- Attaching/detaching of the cap and the Cascading Cable may cause misalignment of rubber grommet in the connector assembly. Press the grommet to the bottom of the connector and attach the connector to the sensor again.

■ When Using the F39-JGR12L Side-by-side Cascading Cable (sold separately)

1. Remove the caps from the primary sensor. Loosen the screw (M2.5 cross-head) to remove the cap.
2. Connect the primary sensor and the secondary sensor with the F39-JGR12L Side-by-side Cascading Cable (sold separately). Do not connect the F3SG-SR upside down. In the figure below, the side with the mark "BTM" on the plastic part of the F3SG-SR must come to the down side.

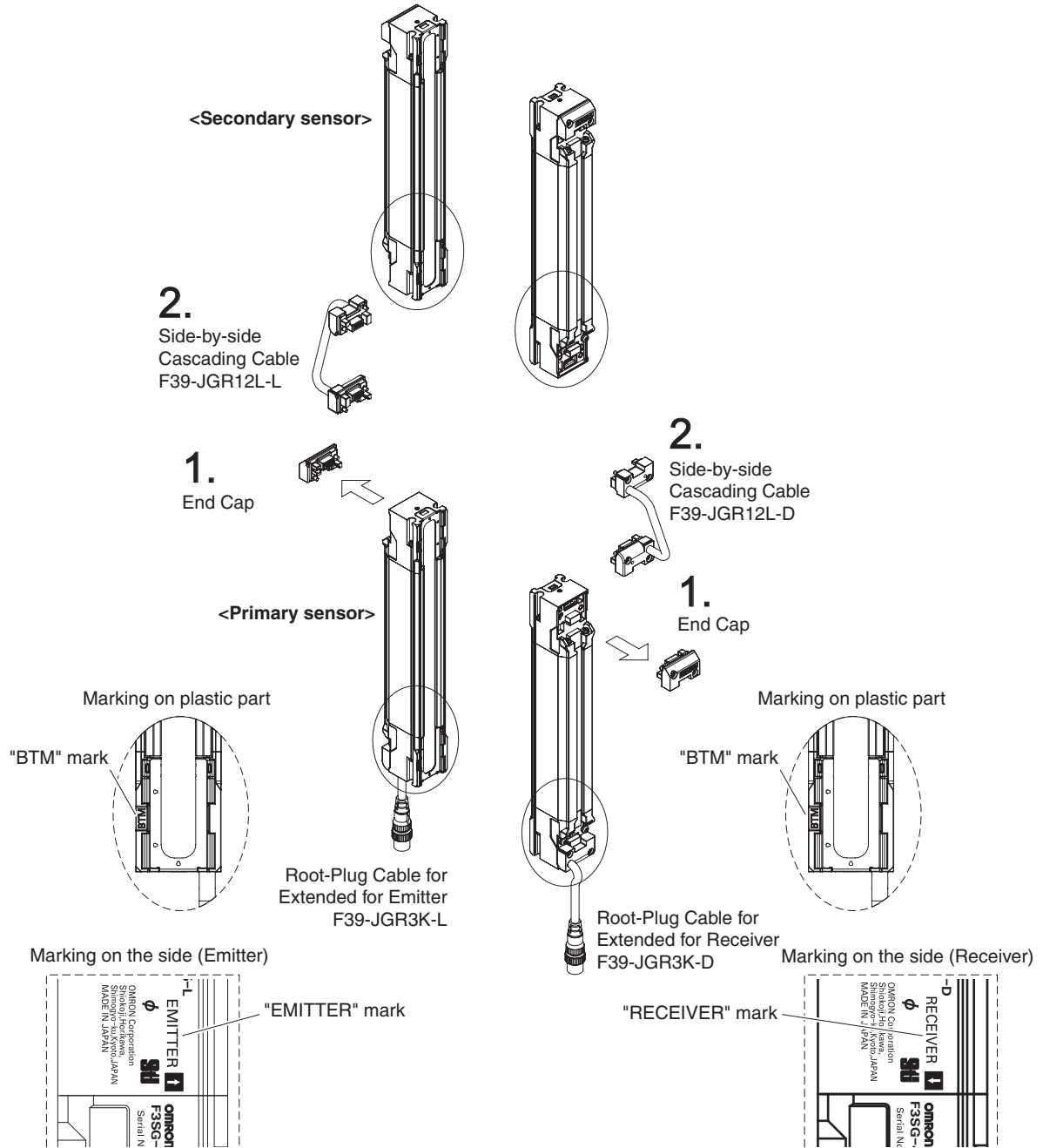

- When attaching a cable or cap, securely fasten the screws (M2.5, recommended torque: 0.35 N•m). Failure to do so may cause the cable/cap to come loose, leading to deterioration of the protective functions.

CHECK!

- Attaching/detaching of the cap and the Cascading Cable may cause misalignment of rubber grommet in the connector assembly. Press the grommet to the bottom of the connector and attach the connector to the sensor again.

Chapter 6 Input/Output Circuit and Applications

6-1. Input/Output Circuit	398
6-1-1. Entire Circuit Diagram	398
6-1-2. Input Circuit Diagram by Function	400
6-2. Wiring Examples (for F3SG-SR/PG)	401
6-2-1. Non-Muting System Wiring Examples	401
6-2-1-1. Auto Reset Mode with Optical Synchronization and EDM Unused	401
6-2-1-2. Auto Reset Mode with Wired Synchronization and EDM Unused	403
6-2-1-3. Auto Reset Mode with Optical Synchronization and EDM Used	404
6-2-1-4. Manual Reset Mode with EDM	405
6-2-1-5. Manual Reset Mode with EDM and Y-Joint Plug/Socket Connector	406
6-2-1-6. Manual Reset Mode with Intelligent Tap	407
6-2-1-7. Manual Reset Mode with Reset Switch Connector	408
6-2-1-8. Pre-Reset Mode with EDM Unused	409
6-2-1-9. Pre-Reset Mode with Reset Switch Connector	410
6-2-1-10. Single Break with EDM and Intelligent Tap	411
6-2-1-11. Double Break with EDM	412
6-2-2. Muting System Wiring Examples	413
6-2-2-1. Standard Muting Mode/Exit-Only Muting Mode	413
6-2-2-2. Standard Muting Mode/Exit-Only Muting Mode with Y-Joint Plug	414
6-2-2-3. Standard Muting Mode/Exit-Only Muting Mode with Intelligent Tap	415
6-2-2-4. Standard Muting Mode/Exit-Only Muting Mode with Reset Switch Connector	416
6-3. Connectable Safety Controllers	417

6-1. Input/Output Circuit

6-1-1. Entire Circuit Diagram

The entire circuit diagrams of the F3SG-SR/PG are shown below.
The numbers in the circles indicate the connector's pin numbers.

6-1-1-1. F3SG-SR and F3SG-PGA-A/-L

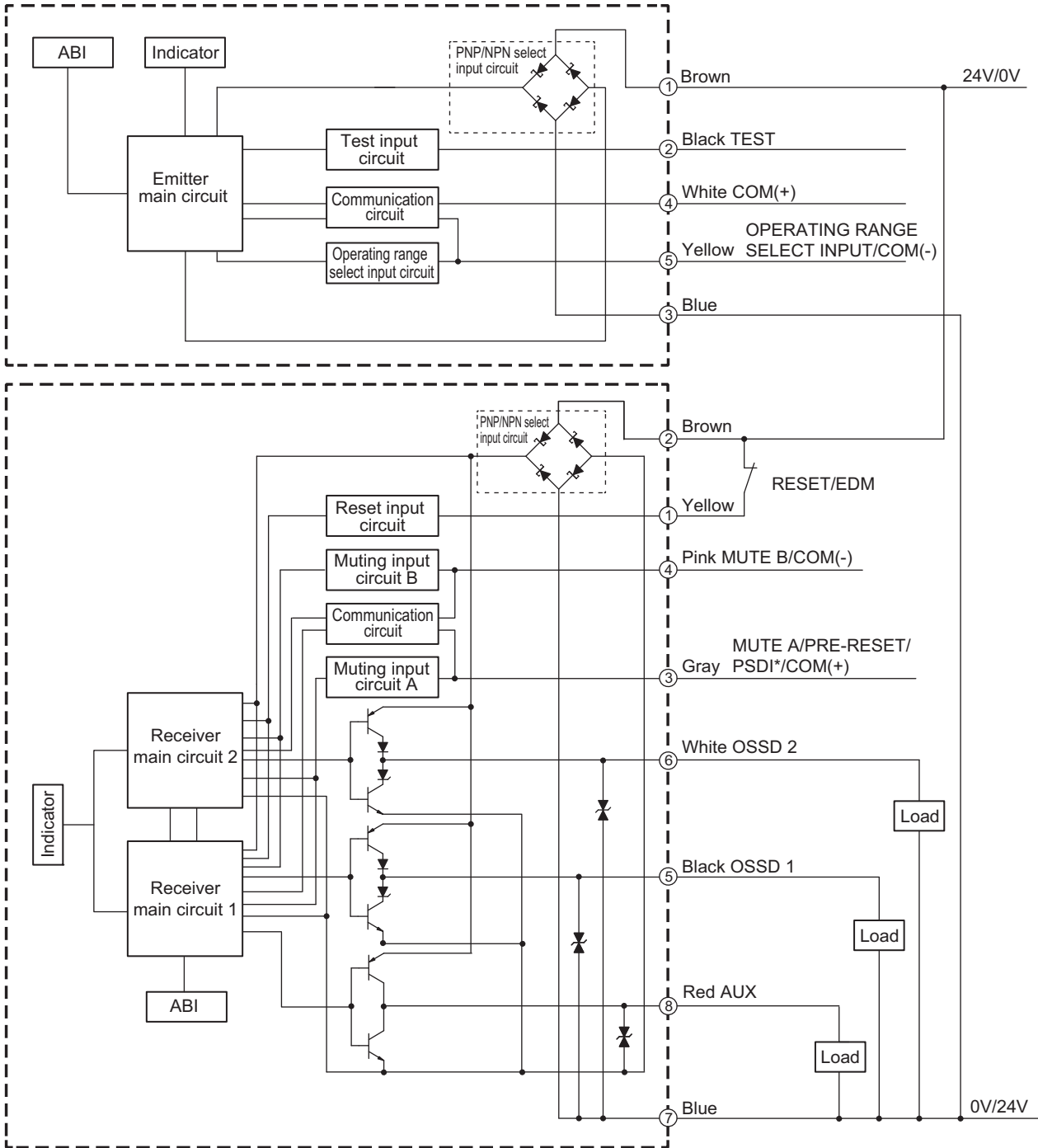

* The function is not supported by F3SG-PG.

6-1-1-2. F3SG-PGA-C

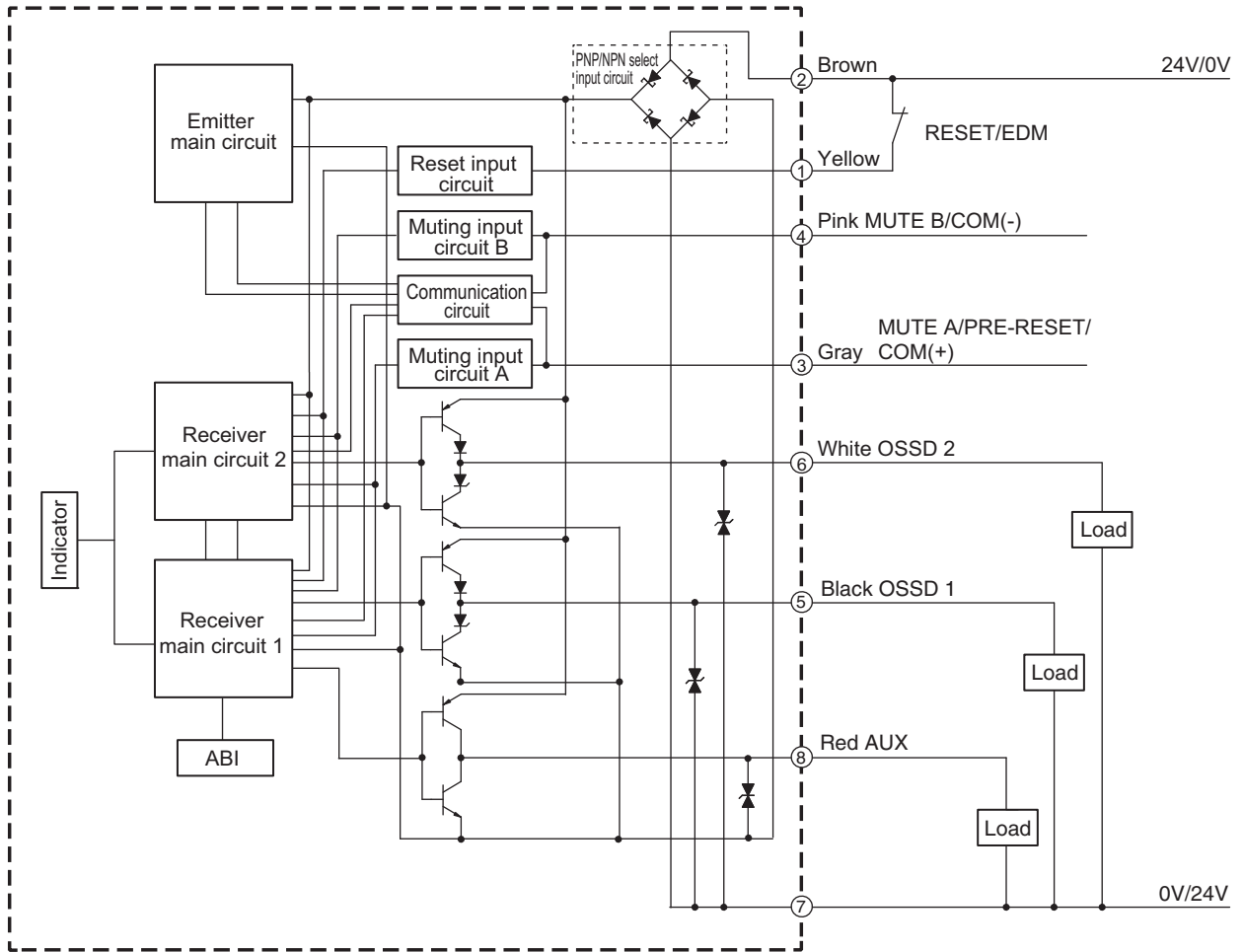

6-1-2. Input Circuit Diagram by Function

The input circuit diagrams of by function are shown below.

■ Test Input*1

<Light emission stops when connected to 24 VDC>

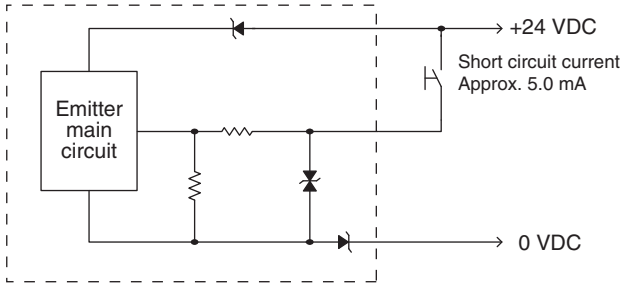

<Light emission stops when connected to 0 V>

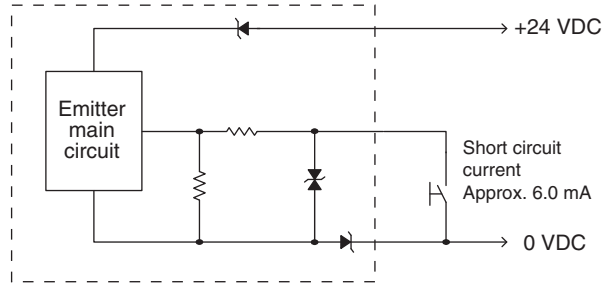

*1 F3SG-PGA-C has no test input function.

■ Test Input, Operating Range Select Input*1

<Long>

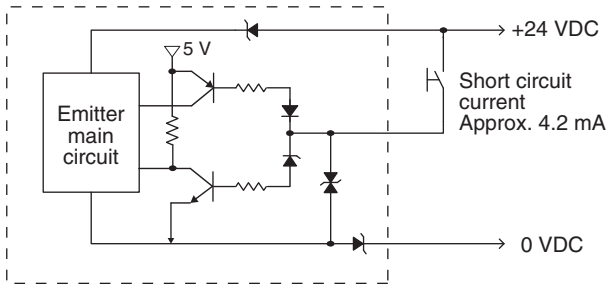

<Short>

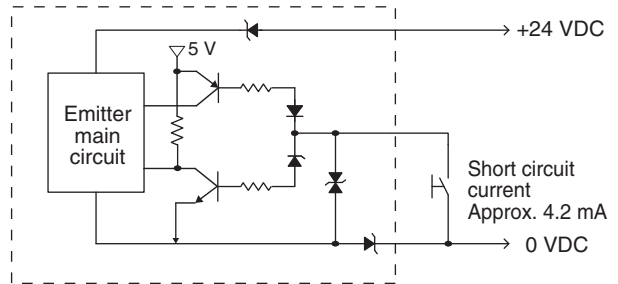

*1 F3SG-PGA-A/-C has no operation range select input function.

■ RESET/EDM, MUTE A/B

<PNP>

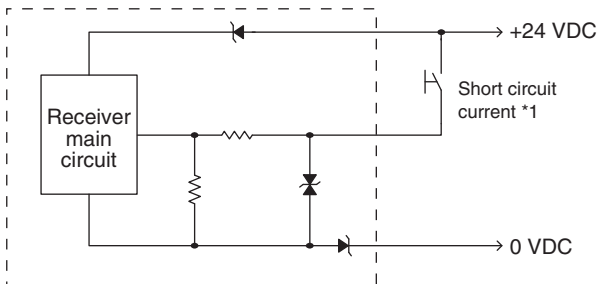

<NPN>

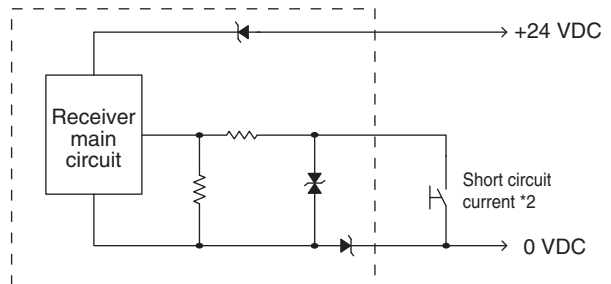

*1. Short circuit current: approx. 9.5 mA (RESET/EDM), approx. 4.5 mA (MUTE A/B)

*2. Short circuit current: approx. 13.0 mA (RESET/EDM), approx. 7.0 mA (MUTE A/B)

6-2. Wiring Examples (for F3SG-SR/PG)

Examples of a motor control system using the F3SG-SR/PG are shown below. This chapter shows examples equivalent to up to PLe, Category 4 (ISO 13849-1). This does NOT mean that the combination of a system can always achieve the performance levels and categories under all the similar conditions and situations. Conformity to the performance levels and categories must be assessed as a whole system. When using F3SG-SR/PG for performance levels and safety categories, perform the installation, inspection, and maintenance properly, and be sure to confirm the conformity as a whole system.

6-2-1. Non-Muting System Wiring Examples

6-2-1-1. Auto Reset Mode with Optical Synchronization and EDM Unused

F3SG-SRA	✓	F3SG-PGA-A/-L	✓
F3SG-SRB	✓	F3SG-PGA-C	✓

[Wiring Example (F3SG-SR and F3SG-PGA-A/-L)]

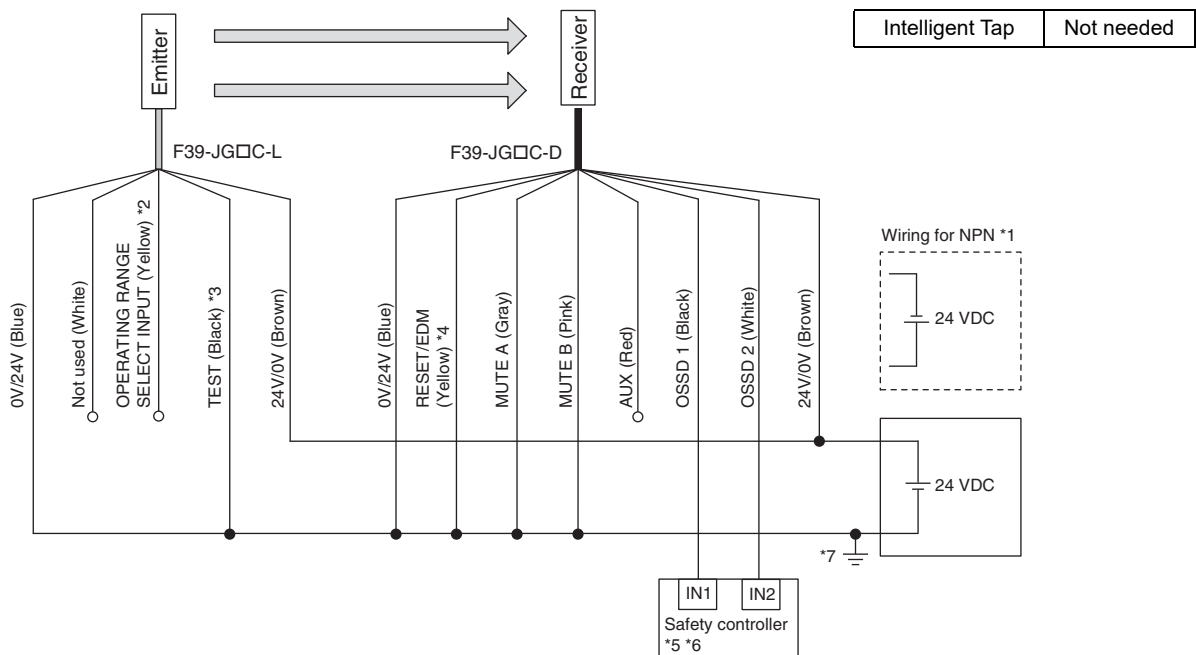

[Wiring Example (F3SG-PGA-C)]

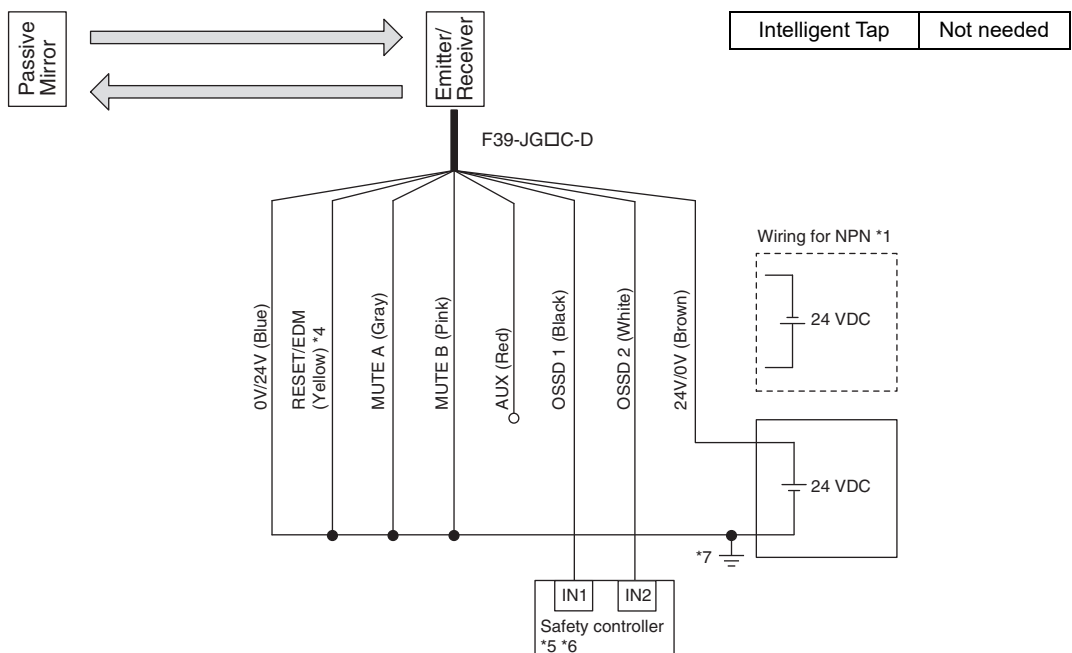

Function	Setting
EDM	EDM Disabled (factory default setting)
Interlock	Auto Reset (factory default setting)
Operating Range Selection	Long : Open the OPERATING RANGE SELECT INPUT line of the emitter or connect the line to 24 VDC.
Non-Muting system	Perform wiring according to the wiring diagram.
External Test not used	Connect the TEST line of the emitter to 0V/24V of the emitter.
Optical Synchronization	Do not connect the COM(+) and COM(-) lines of the of emitter and receiver with each other. *8

Timing chart

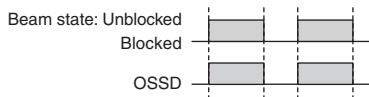

- *1. Reverse the polarity of the power supply when using in the NPN system. Select a safety controller of PNP or NPN type according to the system of your application.
- *2. Connect the line to 0 VDC if F3SG-SR or F3SG-PGA-L is used in Short Mode. F3SG-PGA-A/-C does not support the Operating Range Selection function.
- *3. Refer to 2-6. *External Test* for more information if External Test is used.
- *4. Connect the line to 24V/0V (brown) of the receiver via a lockout reset switch (NC contact) if Lockout Reset is used.
- *5. Refer to 6-3. *Connectable Safety Controllers* for more information.
- *6. The safety controller and the F3SG-SR/PG must share the power supply or be connected to the common terminal of the power supply.
- *7. This is the case for a PELV circuit.
- *8. If the Intelligent Tap is not connected to emitter/receiver of F3SG-PGA-C, the setting becomes the optical synchronization.



- Functional earth connection to the F3SG-SR/PG housing is unnecessary when you use the F3SG-SR/PG in a general industrial environment where noise control or stable power supply is considered. However, when you use the F3SG-SR/PG in an environment where there may be excessive noise from surroundings or stable power supply may be interfered, it is recommended the F3SG-SR/PG be connected to functional earth.
- The wiring examples in later pages do not indicate functional earth. To use functional earth, wire an earth cable according to the example above. Refer to 5-4-4. *Functional Earth Connection* for more information.

6-2-1-2. Auto Reset Mode with Wired Synchronization and EDM Unused

F3SG-SRA	✓	F3SG-PGA-A/L	✓
F3SG-SRB	✓	F3SG-PGA-C	

[Wiring Example (F3SG-SR and F3SG-PGA-A/L)]

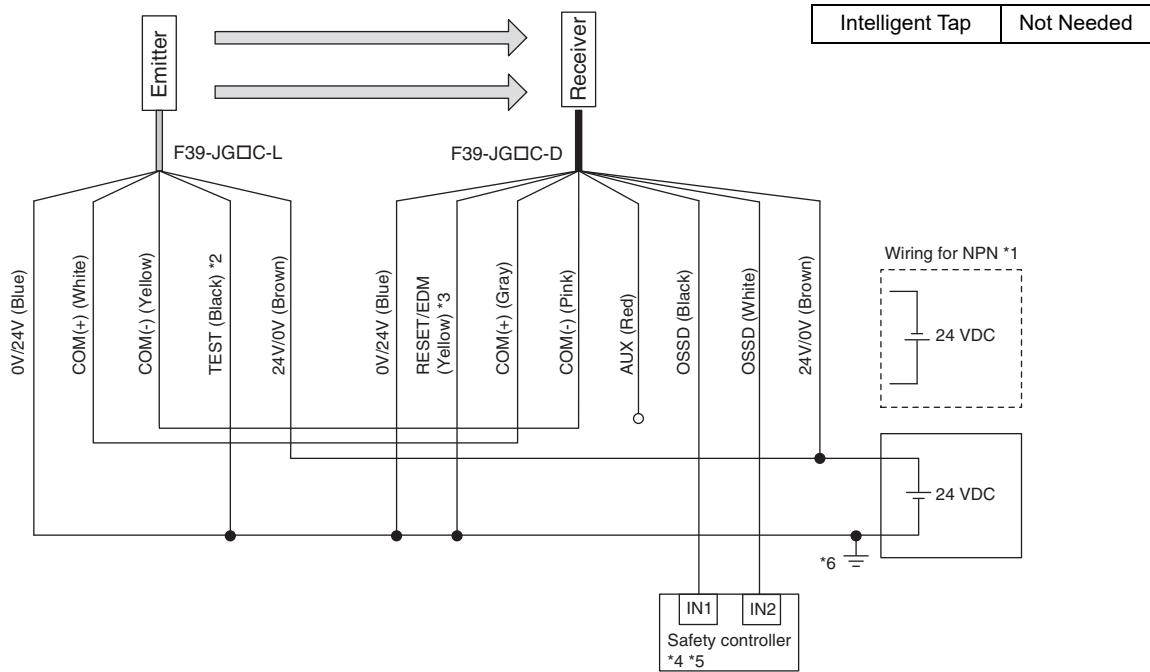

Function	Setting
EDM	EDM Disabled (factory default setting)
Interlock	Auto Reset (factory default setting)
Operating Range Selection	Long (factory default setting)
Non-Muting system	Perform wiring according to the wiring diagram.
External Test not used	Connect the TEST line of the emitter to 0V/24V of the emitter.
Optical Synchronization	Connect the COM(+) and COM(-) line of the emitter and receiver with each other.

Timing chart



- *1. Reverse the polarity of the power supply when using in the NPN system. Select a safety controller of PNP or NPN type according to the system of your application.
- *2. Refer to 2-6. *External Test* for more information if External Test is used.
- *3. Connect the line to 24V/0V (brown) of the receiver via a lockout reset switch (NC contact) if Lockout Reset is used.
- *4. Refer to 6-3. *Connectable Safety Controllers* for more information.*6
- *5. The safety controller and the F3SG-SR/PG must share the power supply or be connected to the common terminal of the power supply.
- *6. This is the case for a PELV circuit.



• When a functional earth is necessary, wire an earth cable according to the example in 6-2-1-1. *Auto Reset Mode with Optical Synchronization and EDM Unused*. Also refer to 5-4-4. *Functional Earth Connection* for more information.

6-2-1-3. Auto Reset Mode with Optical Synchronization and EDM Used

F3SG-SRA	✓	F3SG-PGA-A/-L	✓
F3SG-SRB	✓	F3SG-PGA-C	✓*6

[Wiring Example (F3SG-SR and F3SG-PGA-A/-L*6)]

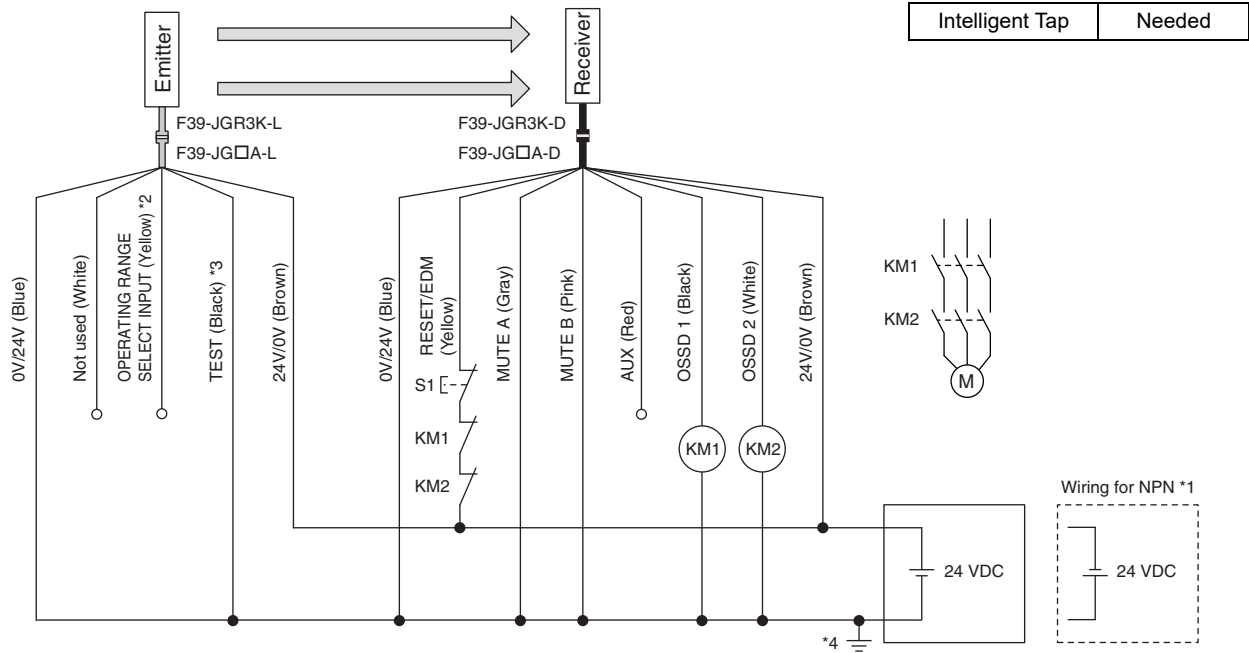

□: Indicates a switch position.

Function	Setting	
	DIP switch	SD Manager 3
EDM *5	EDM Enabled 3 <input checked="" type="checkbox"/> ON	[External device monitoring] : Enable
Interlock	Auto Reset (factory default setting)	
Operating Range Selection	Long : Open the OPERATING RANGE SELECT INPUT line of the emitter or connect the line to 24 VDC.	
Non-Muting system	Perform wiring according to the wiring diagram.	
	N/A	[Muting] : Disable
External Test not used	Connect the TEST line of the emitter to 0V/24V of the emitter.	
Optical Synchronization	Do not connect the COM(+) and COM(-) lines of the of emitter and receiver with each other.	

Timing chart

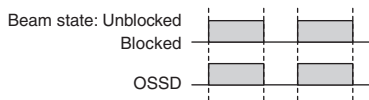

S1: Lockout reset switch

KM1, KM2: Safety relay with forcibly guided contacts (G7SA) or magnetic contactor
M: Motor

- *1. Reverse the polarity of the power supply when using in the NPN system.
- *2. Connect the line to 0 VDC if F3SG-SR or F3SG-PGA-L is used in Short Mode. F3SG-PGA-A/-C does not support the Operating Range Selection function.
- *3. Refer to 2-6. *External Test* for more information if External Test is used.
- *4. This is the case for a PELV circuit.
- *5. Set the function with the DIP Switches on the Intelligent Tap or the SD Manager 3, restore the settings to the F3SG-SR/PG, and perform wiring according to the wiring diagram.
- *6. To use F3SG-PGA-C, wire the receiver side of the emitter/receiver of F3SG-PGA-C as shown in the above figure. Wiring of the emitter side is not needed.



CHECK!

When a functional earth is necessary, wire an earth cable according to the example in 6-2-1-1. *Auto Reset Mode with Optical Synchronization and EDM Unused*. Also refer to 5-4-4. *Functional Earth Connection* for more information.

6-2-1-4. Manual Reset Mode with EDM

F3SG-SRA	✓	F3SG-PGA-A/L	✓
F3SG-SRB	✓	F3SG-PGA-C	✓*6

[Wiring Example (F3SG-SR and F3SG-PGA-A/L*6)]

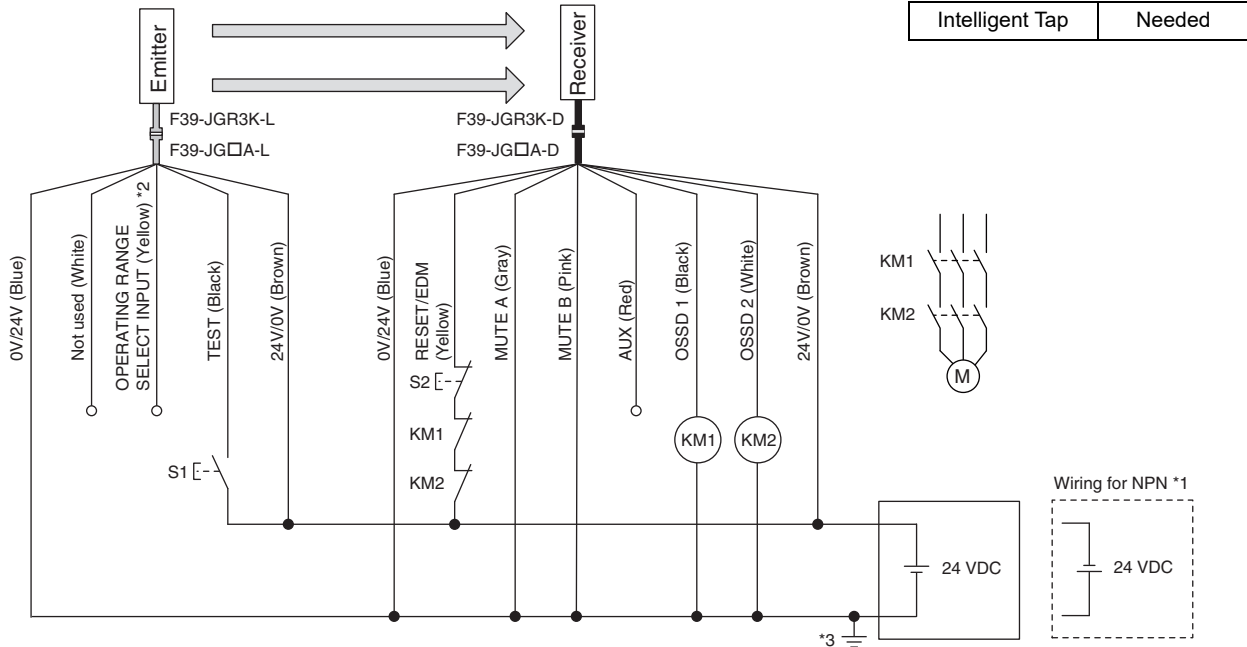

□: Indicates a switch position.

Function	Setting	
	DIP switch	SD Manager 3
EDM *4	EDM Enabled 3 <input type="checkbox"/> ON	[External device monitoring] : Enable
Interlock *4	Manual Reset 4 <input type="checkbox"/> ON 5 <input type="checkbox"/> ON	[Start interlock] : Enable [Restart interlock] : Enable
Operating Range Selection	Long : Open the OPERATING RANGE SELECT INPUT line of the emitter or connect the line to 24 VDC.	
Non-Muting system	Perform wiring according to the wiring diagram. N/A [Muting] : Disable *4	
External Test used *7	Connect the TEST line of the emitter to 24V/0V of the emitter via a test switch (NO contact). *5 N/A [External test signal inversion] : Disable	
Optical Synchronization	Perform wiring according to the wiring diagram.	

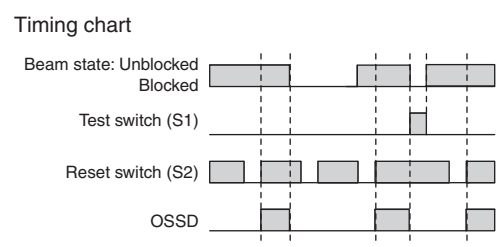

- S1: Test switch
- S2: Lockout/interlock reset switch
- KM1, KM2: Safety relay with forcibly guided contacts (G7SA) or magnetic contactor
- M: Motor
- *1. Reverse the polarity of the power supply when using in the NPN system.
- *2. Connect the line to 0 VDC if Operating Range Selection is used in Short Mode on F3SG-SR and F3SG-PGA-L.
- *3. This is the case for a PELV circuit.
- *4. Set the function with the DIP Switches on the Intelligent Tap or the SD Manager 3, restore the settings to the F3SG-SR/PG, and perform wiring according to the wiring diagram.
- *5. This wiring example shows light emission stop when connected to 24 VDC with PNP setting, and light emission stop when connected to 0 VDC with NPN setting. If TEST switch is not needed, refer to 2-6. External Test.
- *6. To use F3SG-PGA-C, wire the receiver side of the emitter/receiver of F3SG-PGA-C as shown in the above figure. Wiring of the emitter side is not needed.
- *7. F3SG-PGA-C does not support the External Test function.

CHECK! When a functional earth is necessary, wire an earth cable according to the example in 6-2-1-1. Auto Reset Mode with Optical Synchronization and EDM Unused. Also refer to 5-4-4. Functional Earth Connection for more information.

6-2-1-5. Manual Reset Mode with EDM and Y-Joint Plug/Socket Connector

F3SG-SRA	✓	F3SG-PGA-A/-L	✓
F3SG-SRB	✓	F3SG-PGA-C	

[Wiring Example (F3SG-SR and F3SG-PGA-A/-L)]

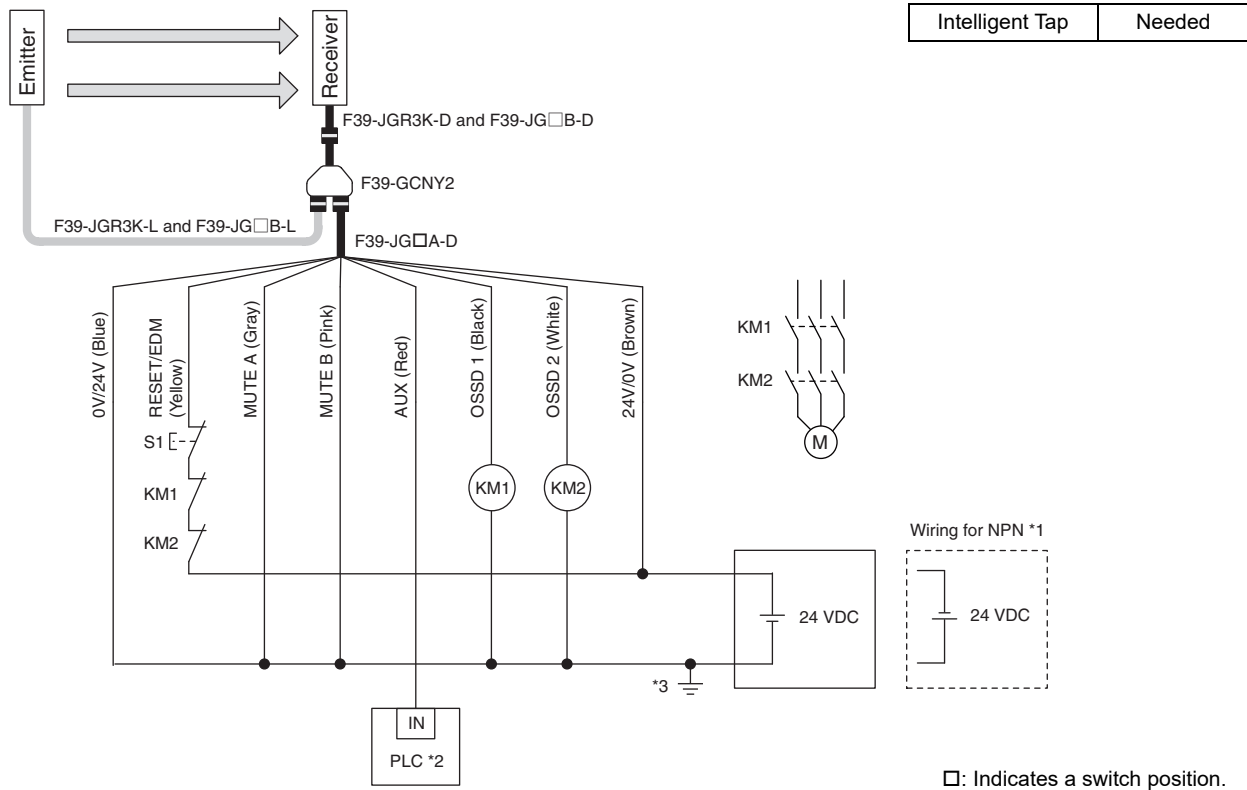

Function	Setting	
	DIP switch	SD Manager 3
EDM *4	EDM Enabled 3 <input type="checkbox"/> ON	[External device monitoring] : Enable
Interlock *4	Manual Reset 4 <input type="checkbox"/> ON	[Start interlock] : Enable
	5 <input type="checkbox"/> ON	[Restart interlock] : Enable
Operating Range Selection	Long	
Non-Muting system	Perform wiring according to the wiring diagram.	
	N/A	[Muting] : Disable *4
External Test not used	N/A	
Optical Synchronization	Connect the wires according to the diagram above.	

Timing chart

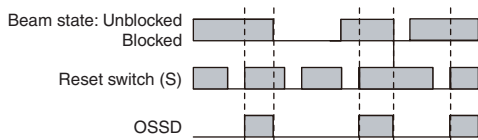

- S1: Lockout/interlock reset switch
- KM1, KM2: Safety relay with forcibly guided contacts (G7SA) or magnetic contactor
- M: Motor
- PLC: Programmable logic controller (Used for monitoring only. NOT related to safety system.)
- *1. Reverse the polarity of the power supply when using in the NPN system. Select a PLC of PNP or NPN type according to the system of your application.
- *2. When connecting to the PLC, the output mode must be changed with the SD Manager 3 according to your application. Refer to *Chapter 4 Setting with SD Manager 3* for more information on setting this function by the SD Manager 3.
- *3. This is the case for a PELV circuit.
- *4. Set the function with the DIP Switches on the Intelligent Tap or the SD Manager 3, restore the settings to the F3SG-SR, and perform wiring according to the wiring diagram.



- When using the Y-Joint Plug/Socket Connector (F39-GCNY2), the following functions are not available.
 - External Test
 - Operating Range Selection
 - Wired Synchronization
- When a functional earth is necessary, wire an earth cable according to the example in 6-2-1-1. *Auto Reset Mode with Optical Synchronization and EDM Unused*. Also refer to 5-4-4. *Functional Earth Connection* for more information.

6-2-1-6. Manual Reset Mode with Intelligent Tap

F3SG-SRA	✓	F3SG-PGA-A/-L	✓
F3SG-SRB	✓	F3SG-PGA-C	✓*7

[Wiring Example (F3SG-SR and F3SG-PGA-A/-L *7)]

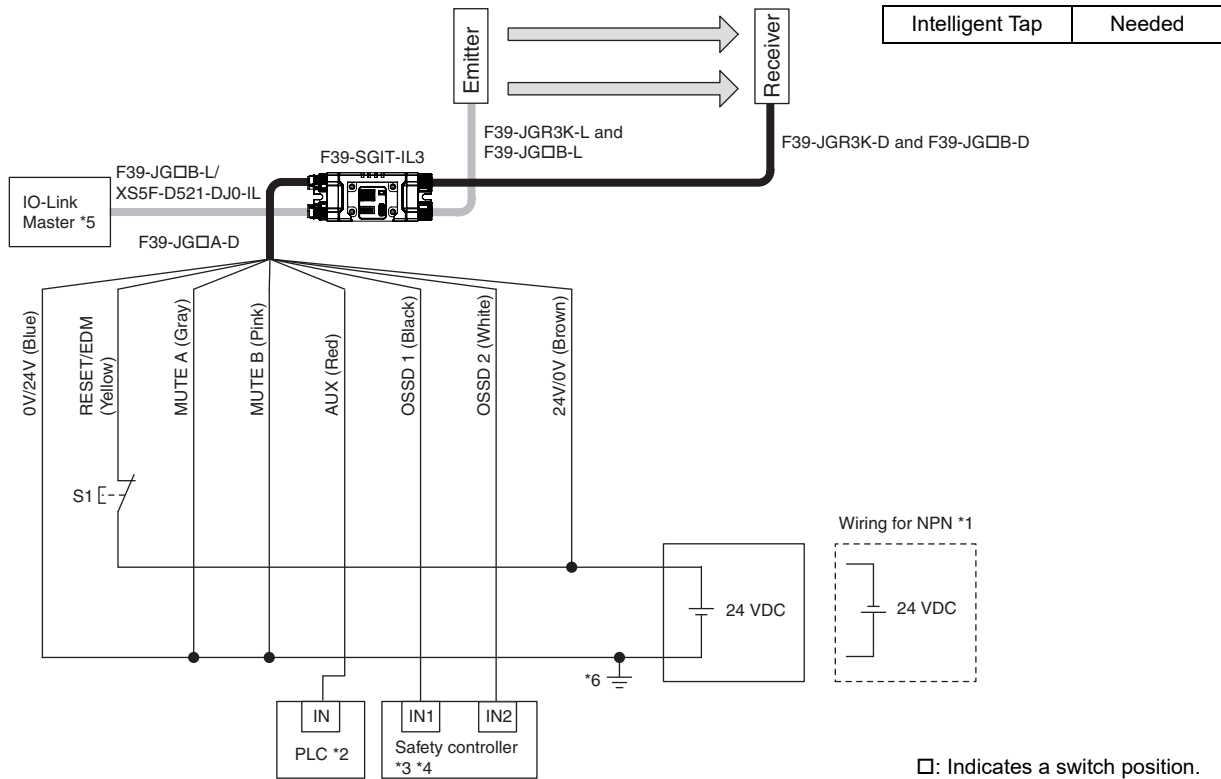

Function	Setting	
	DIP switch	SD Manager 3
EDM *8	EDM Disabled 3 <input type="checkbox"/> ON	[External device monitoring] : Disable
Interlock *8	Manual Reset 4 <input type="checkbox"/> ON	[Start interlock] : Enable
	5 <input type="checkbox"/> ON	[Restart interlock] : Enable
Operating Range Selection *9	Long 8 <input type="checkbox"/> ON	[Operating Range Selection] : Long mode
Non-Muting system	Perform wiring according to the wiring diagram.	
	N/A	[Muting] : Disable
Test Input	N/A	
Wired Synchronization	Connect the emitter and receiver with the Intelligent Tap.	

Timing chart

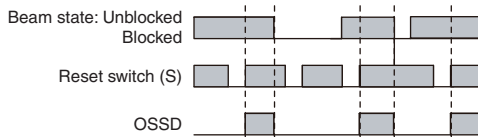

S1: Lockout/interlock reset switch
 PLC: Programmable logic controller (Used for monitoring only, NOT related to safety system.)

- Reverse the polarity of the power supply when using in the NPN system. Select a PLC and a safety controller of PNP or NPN type according to the system of your application.
- When connecting to the PLC, the output mode must be changed with the SD Manager 3 according to your application. Refer to *Chapter 4 Setting with SD Manager 3* for more information on setting this function by the SD Manager 3.
- Refer to 6-3. *Connectable Safety Controllers* for more information.
- The safety controller and the F3SG-SR/PG must share the power supply or be connected to the common terminal of the power supply.
- For connecting with the IO-Link Master unit, refer to an instruction manual of the IO-Link Master unit you use.
- This is the case for a PELV circuit.
- To use F3SG-PGA-C, wire the receiver side of the emitter/receiver of F3SG-PGA-C as shown in the above figure. Wiring of the emitter side is not needed.
- Make settings using the DIP Switch of the intelligent tap or SD Manager 3.
- To use F3SG-SR and F3SG-PGA-L in Short Mode, make settings using the DIP Switch of the intelligent tap or SD Manager 3, restore to F3SG-SR/PG, and wire according to the wiring diagram. F3SG-PGA-A/-C does not support the Operating Range Selection function.



- When using the Intelligent Tap (F39-SGIT-IL3) with the emitter and receiver connected, the following functions are not available.
 - External Test
 - Operating Range Selection by wiring
 - Optical Synchronization
- When a functional earth is necessary, wire an earth cable according to the example in 6-2-1-1. *Auto Reset Mode with Optical Synchronization and EDM Unused*. Also refer to 5-4-4. *Functional Earth Connection* for more information.

6-2-1-7. Manual Reset Mode with Reset Switch Connector

F3SG-SRA	✓	F3SG-PGA-A/-L	✓
F3SG-SRB	✓	F3SG-PGA-C	✓*8

[Wiring Example (F3SG-SR and F3SG-PGA-A/-L*8)]

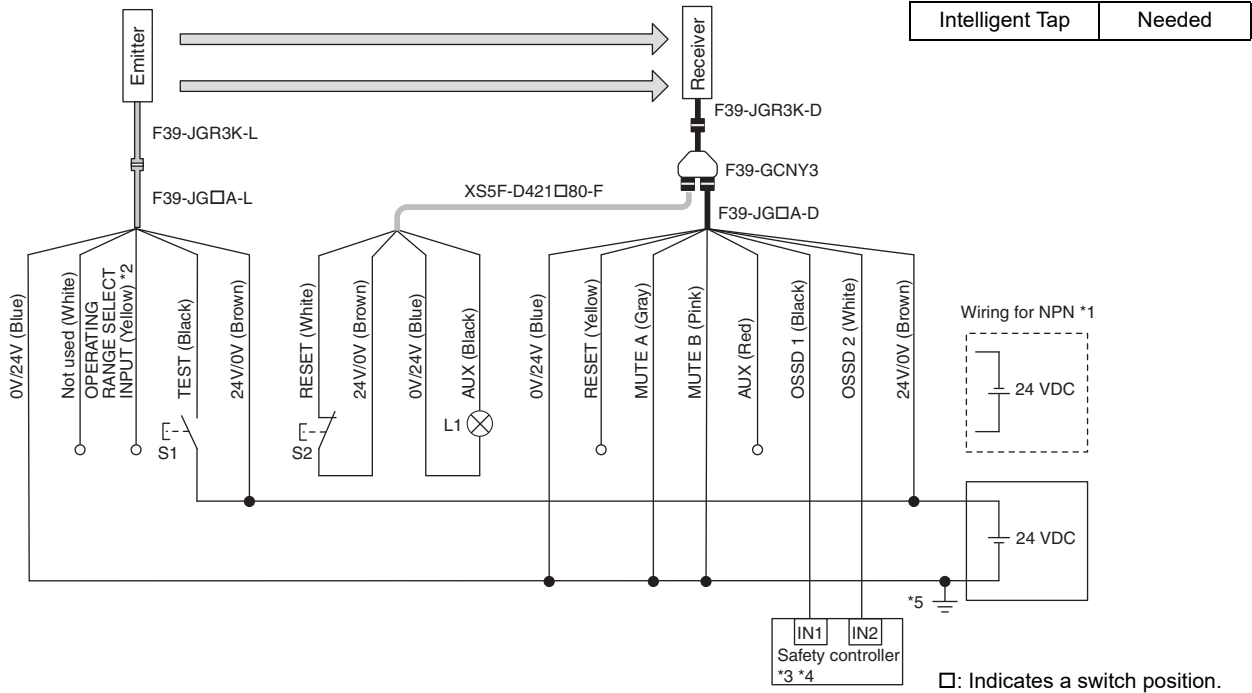

Function	Setting	
	DIP switch	SD Manager 3
EDM	EDM Disabled (factory default setting)	[EDM]: Disabled
Interlock *6	Manual Reset 4 <input checked="" type="checkbox"/> ON 5 <input checked="" type="checkbox"/> ON	[Start interlock]: Enable [Restart interlock]: Enable
Operating Range Selection	Long : Open the OPERATING RANGE SELECT INPUT line of the emitter or connect the line to 24 VDC.	
Non-Muting system	Perform wiring according to the wiring diagram.	
	N/A	[Muting]: Disable *6
External Test used *9	Connect the TEST line of the emitter to 24V/0V of the emitter via a test switch (NO contact). *7	
	N/A	[External test signal inversion]: Disable
Optical Synchronization	Open the COM(+) and COM(-) lines of the emitter.	

S1: Test switch
S2: Lockout/interlock reset switch
L1: Lamp

Timing chart



- Reverse the polarity of the power supply when using in the NPN system. Select a safety controller of PNP or NPN type according to the system of your application.
- Connect the line to 0 VDC if F3SG-SR or F3SG-PGA-L is used in Short Mode. F3SG-PGA-A/-C does not support the Operating Range Selection function.
- Refer to 6-3. *Connectable Safety Controllers* for more information.
- The safety controller and the F3SG-SR/PG must share the power supply or be connected to the common terminal of the power supply.
- This is the case for a PELV circuit.
- Set the function with the DIP Switches on the Intelligent Tap or the SD Manager 3, restore the settings to the F3SG-SR/PG, and perform wiring according to the wiring diagram.
- This wiring example shows light emission stop when connected to 24 VDC with PNP setting, and light emission stop when connected to 0 VDC with NPN setting. If TEST switch is not needed, refer to 2-6. *External Test*.
- To use F3SG-PGA-C, wire the receiver side of the emitter/receiver of F3SG-PGA-C as shown in the above figure. Wiring of the emitter side is not needed.
- F3SG-PGA-C does not support the External Test function.



- When using the Reset Switch Connector (F39-GCNY3), the following functions are not available.
 - External Device Monitoring (EDM)
- When a functional earth is necessary, wire an earth cable according to the example in 6-2-1-1. *Auto Reset Mode with Optical Synchronization and EDM Unused*. Also refer to 5-4-4. *Functional Earth Connection* for more information.

6-2-1-8. Pre-Reset Mode with EDM Unused

F3SG-SRA	✓	F3SG-PGA-A/L	✓
F3SG-SRB	✓	F3SG-PGA-C	✓*8

[Wiring Example (F3SG-SR and F3SG-PGA-A/L*8)]

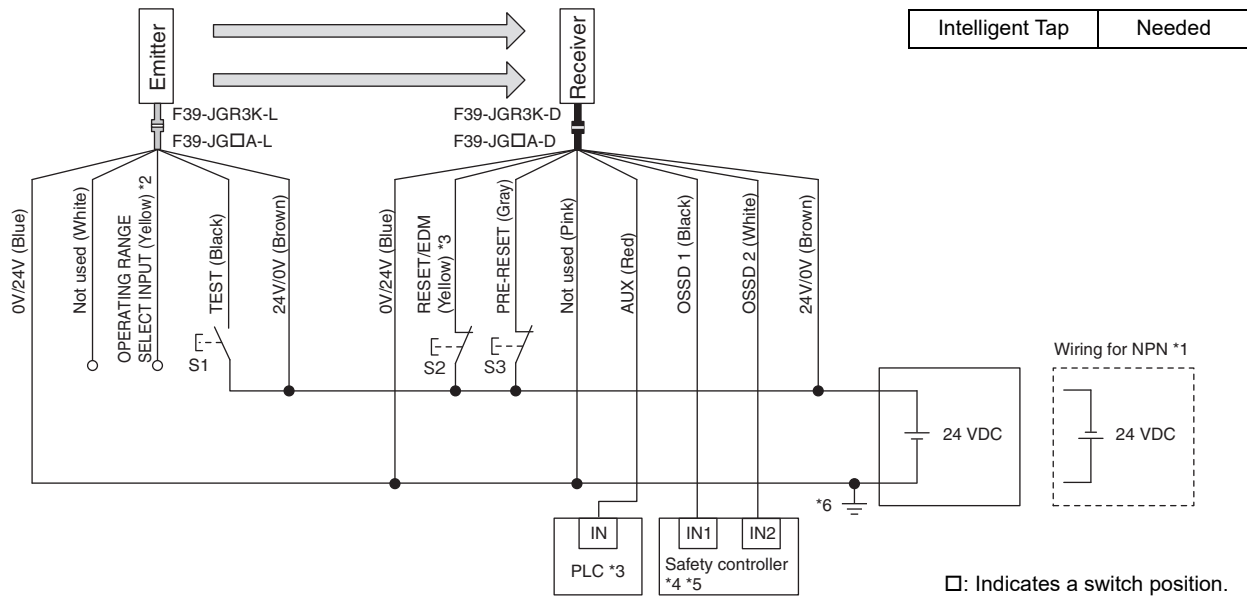

Function	Setting	
	DIP switch	SD Manager 3
EDM *7	EDM Disabled (factory default setting)	
	EDM Disabled 3 <input type="checkbox"/> ON	[External device monitoring] : Disable
Pre-Reset *7	Pre-Reset 4 <input type="checkbox"/> ON	[Pre-Reset] : Enable
	5 <input type="checkbox"/> ON	
Operating Range Selection	Long : Open the OPERATING RANGE SELECT INPUT line of the emitter or connect the line to 24 VDC.	
Non-Muting system	Perform wiring according to the wiring diagram.	
External Test used *9	Connect the TEST line of the emitter to 24V/0V of the emitter via a test switch (NO contact).	
Optical Synchronization	Do not connect the COM(+) and COM(-) lines of the of emitter and receiver with each other.	

- S1: Test switch
- S2: Lockout/interlock reset switch
- S3: Pre-reset switch
- PLC: Programmable logic controller (Used for monitoring only, NOT related to safety system.)
- *1. Reverse the polarity of the power supply when using in the NPN system. Select a PLC and a safety controller of PNP or NPN type according to the system of your application.
- *2. Connect the line to 0 VDC if F3SG-SR or F3SG-PGA-L is used in Short Mode. F3SG-PGA-A/C does not support the Operating Range Selection function.
- *3. When connecting to the PLC, the output mode must be changed with the SD Manager 3 according to your application. Refer to *Chapter 4 Setting with SD Manager 3* for more information on setting this function by the SD Manager 3.
- *4. Refer to 6-3. *Connectable Safety Controllers* for more information.
- *5. The safety controller and the F3SG-SR/PG must share the power supply or be connected to the common terminal of the power supply.
- *6 This is the case for a PELV circuit.
- *7 Set the function with the DIP Switches on the Intelligent Tap or the SD Manager 3, restore the settings to the F3SG-SR/PG, and perform wiring according to the wiring diagram.
- *8. To use F3SG-PGA-C, wire the receiver side of the emitter/receiver of F3SG-PGA-C as shown in the above figure. Wiring of the emitter side is not needed.
- *9. F3SG-PGA-C does not support the External Test function.

Timing chart

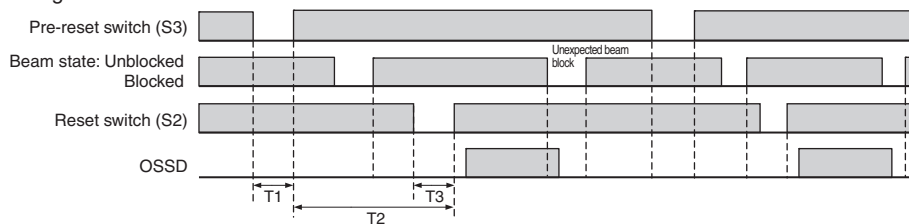

T1: Minimum pressing time of pre-reset switch. Configurable from 100 to 500 ms in 100-ms increments.
 T2: Maximum permissible time from input of PRE-RESET signal to input of RESET signal. Configurable from 1 to 60 s in 1-s increments.
 T3: Minimum pressing time of reset switch. Configurable from 100 to 500 ms in 100-ms increments.



When a functional earth is necessary, wire an earth cable according to the example in 6-2-1-1. *Auto Reset Mode with Optical Synchronization and EDM Unused*. Also refer to 5-4-4. *Functional Earth Connection* for more information.

6-2-1-9. Pre-Reset Mode with Reset Switch Connector

F3SG-SRA	✓	F3SG-PGA-A/-L	✓
F3SG-SRB	✓	F3SG-PGA-C	✓*8

[Wiring Example (F3SG-SR and F3SG-PGA-A/-L*8)]

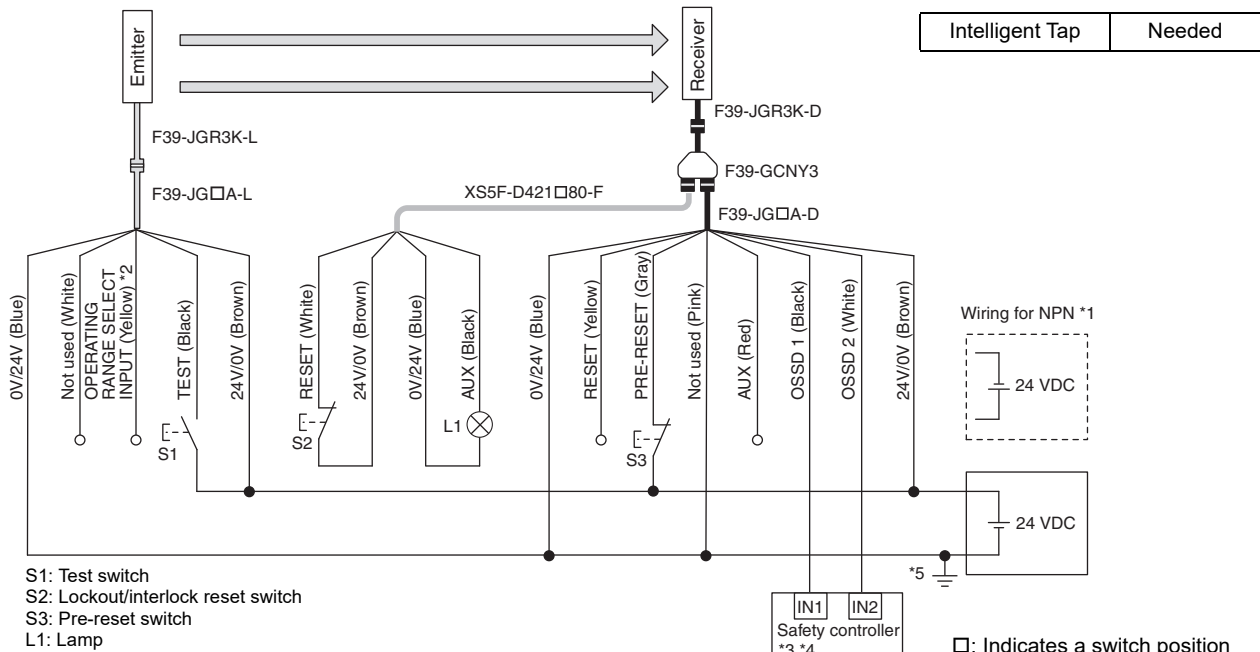

S1: Test switch
 S2: Lockout/interlock reset switch
 S3: Pre-reset switch
 L1: Lamp

Function	Setting	
	DIP switch	SD Manager 3
EDM	N/A	
Pre-Reset *6	Pre-Reset 4 <input type="checkbox"/> ON 5 <input type="checkbox"/> ON	[Pre-Reset] : Enable
Non-Muting system	Perform wiring according to the wiring diagram.	
	N/A	[Muting] : Disable *6
Operating Range Selection	Long : Open the OPERATING RANGE SELECT INPUT line of the emitter or connect the line to 24 VDC.	
External Test used *9	Connect the TEST line of the emitter to 24V/0V via a test switch (NO contact). *7	
	N/A	[External test signal inversion] : Disable
Optical Synchronization	Do not connect the COM(+) and COM(-) lines of the of emitter and receiver with each other.	

- *1. Reverse the polarity of the power supply when using in the NPN system. Select a safety controller of PNP or NPN type according to the system of your application.
- *2. Connect the line to 0 VDC if F3SG-SR or F3SG-PGA-L is used in Short Mode. F3SG-PGA-A/-C does not support the Operating Range Selection function.
- *3. Refer to 6-3. *Connectable Safety Controllers* for more information.
- *4. The safety controller and the F3SG-SR/PG must share the power supply or be connected to the common terminal of the power supply.
- *5. This is the case for a PELV circuit.
- *6. Set the function with the DIP Switches on the Intelligent Tap or the SD Manager 3, restore the settings to the F3SG-SR/PG, and perform wiring according to the wiring diagram.
- *7. This is the example for the PNP system to stop emission when the line is connected to 24 VDC and for the NPN to stop emission when the line is connected to 0 VDC. If TEST switch is not needed, refer to 2-6. *External Test*.
- *8. To use F3SG-PGA-C, wire the receiver side of the emitter/receiver of F3SG-PGA-C as shown in the above figure. Wiring of the emitter side is not needed.
- *9. F3SG-PGA-C does not support the External Test function.

Timing chart

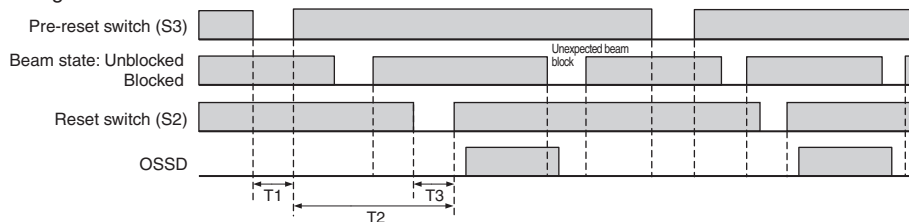

T1: Minimum pressing time of pre-reset switch. Configurable from 100 to 500 ms in 100-ms increments.
 T2: Maximum permissible time from input of PRE-RESET signal to input of RESET signal. Configurable from 1 to 60 s in 1-s increments.
 T3: Minimum pressing time of reset switch. Configurable from 100 to 500 ms in 100-ms increments.



- When using the Reset Switch Connector (F39-GCNY3), the following functions are not available.
 - External Device Monitoring (EDM)
- When a functional earth is necessary, wire an earth cable according to the example in 6-2-1-1. *Auto Reset Mode with Optical Synchronization and EDM Unused*. Also refer to 5-4-4. *Functional Earth Connection* for more information.

6-2-1-10. Single Break with EDM and Intelligent Tap

F3SG-SRA	✓	F3SG-PGA-A/L	
F3SG-SRB	✓	F3SG-PGA-C	

[Wiring Example (F3SG-SR)]

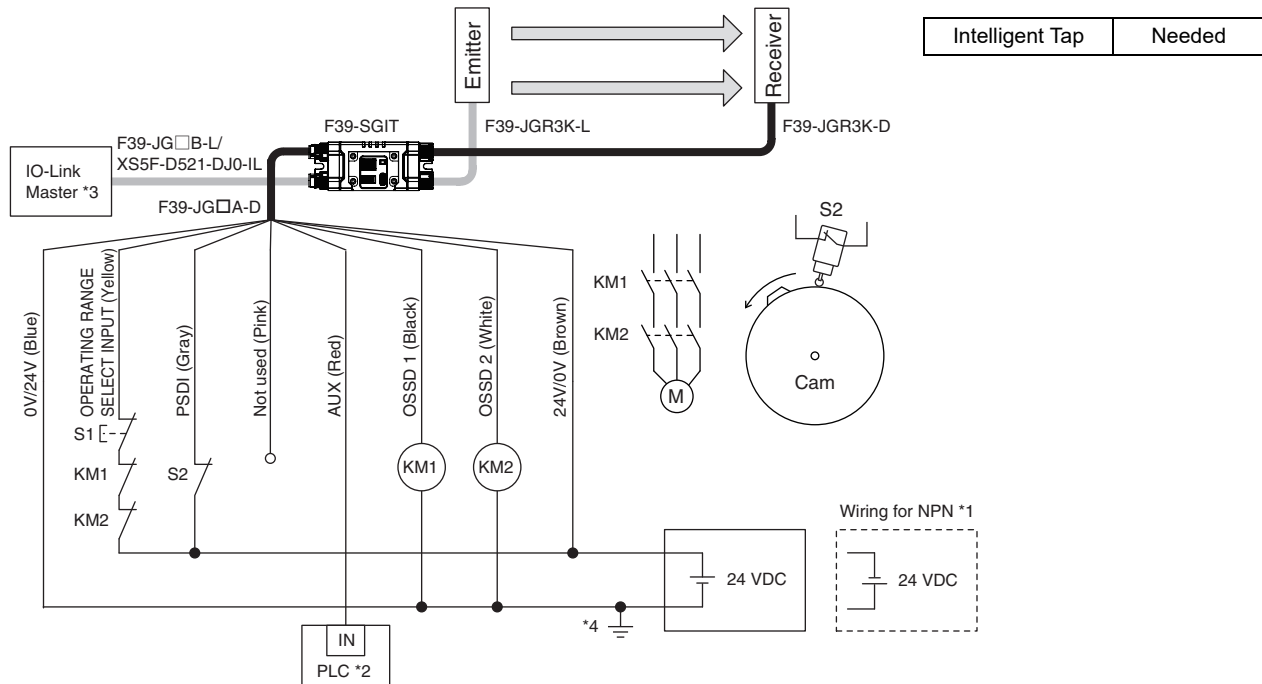

Function	Setting	
	DIP switch *6	SD Manager 3
EDM	-	[External device monitoring] : Enable
Operating Range Selection *5	-	[Operating Range Selection] : Long mode
	-	[Operating Range Selection] : Short mode
PSDI	N/A	[PSDI] : Single break
Non-Muting system	Perform wiring according to the wiring diagram.	
	N/A	[Muting] : Disable
External Test not used	N/A	
Wired Synchronization	Connect the emitter and receiver with the Intelligent Tap.	

- S1: Reset switch
- S2: Press position switch
- KM1, KM2: Safety relay with forcibly guided contacts (G7SA) or magnetic contactor
- PLC: Programmable logic controller (Used for monitoring only. NOT related to safety system.)
- M: Motor

- Reverse the polarity of the power supply when using in the NPN system. Select a PLC of PNP or NPN type according to the system of your application.
- When connecting to the PLC, the output mode must be changed with the SD Manager 3 according to your application. Refer to *Chapter 4 Setting with SD Manager 3* for more information on setting the functions by the SD Manager 3.
- For connecting with the IO-Link Master unit, refer to an instruction manual of the IO-Link Master unit you use.
- This is the case for a PELV circuit.
- F3SG-SR and F3SG-PGA-L can be set up in both Long Mode and Short Mode. F3SG-PGA-A/C does not support the Operating Range Selection function.
- The PSDI is only configurable by the SD Manager 3, not by the DIP Switch.

Timing chart

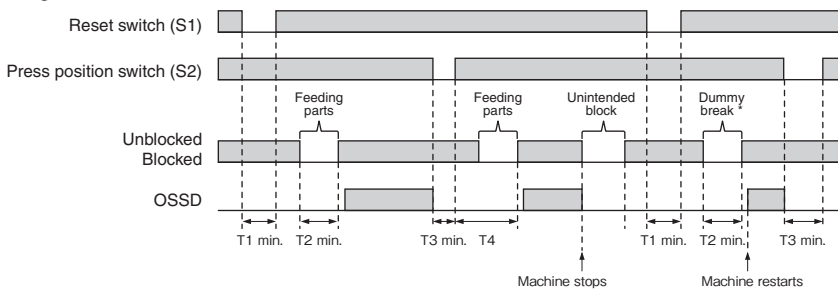

- T1: Minimum pressing time of reset switch. Configurable from 100 to 500 ms in 100-ms increments by SD Manager 3.
- T2: Minimum break time (300 ms)
- T3: Minimum pressing time of press position switch. T3 = T1
- T4: Wait time until single break is complete (30 s or less)

* When the machine is stopped by unintended block in the middle of pressing of parts, operation of the switch (S1) and then a single dummy break are needed for reinitiation of the machine cycle.



- When using the Intelligent Tap (F39-SGIT-IL3) with the emitter and receiver connected, the following functions are not available.
 - External Test
 - Operating Range Selection by wiring
 - Optical Synchronization
- When a functional earth is necessary, wire an earth cable according to the example in 6-2-1-1. *Auto Reset Mode with Optical Synchronization and EDM Unused*. Also refer to 5-4-4. *Functional Earth Connection* for more information.

6-2-1-11. Double Break with EDM

F3SG-SRA	✓	F3SG-PGA-A/-L	
F3SG-SRB	✓	F3SG-PGA-C	

[Wiring Example (F3SG-SR)]

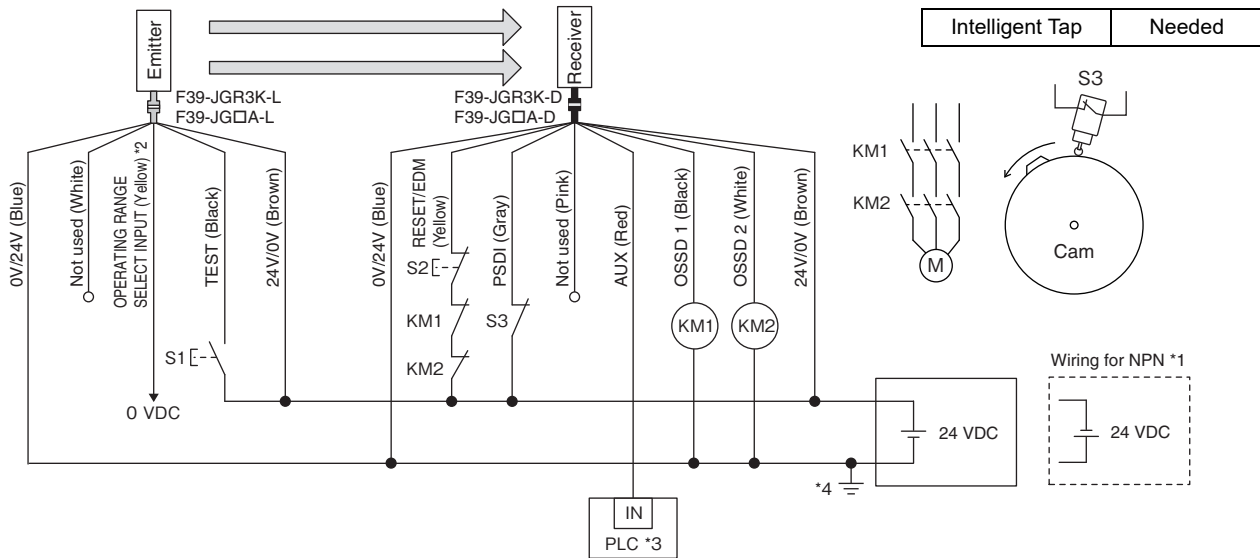

Function	Setting	
	DIP switch	SD Manager 3
EDM	-	[External device monitoring] : Enable *5
Operating Range Selection	Short : Connect the OPERATING RANGE SELECT INPUT line of the emitter to 0 VDC.	
PSDI	N/A	[PSDI] : Double break *5
Non-Muting system	Perform wiring according to the wiring diagram.	
	N/A	[Muting] : Disable *5
External Test used	Connect the TEST line of the emitter to 24V/0V of the emitter via a test switch (NO contact). *6	
	N/A	[External test signal inversion] : Disable
Optical Synchronization	Do not connect the COM(+) and COM(-) lines of the of emitter and receiver with each other.	

S1: Test switch
 S2: Reset switch
 S3: Press position switch
 KM1, KM2: Safety relay with forcibly guided contacts (G7SA) or magnetic contactor
 PLC: Programmable logic controller (Used for monitoring only. NOT related to safety system.)
 M: Motor

- Reverse the polarity of the power supply when using in the NPN system. Select a PLC of PNP or NPN type according to the system of your application.
- Open or connect the line to 24 VDC if Operating Range Selection is used in Long Mode.
- When connecting to the PLC, the output mode must be changed with the SD Manager 3 according to your application. Refer to *Chapter 4 Setting with SD Manager 3* for more information on setting the functions by the SD Manager 3.
- This is the case for a PELV circuit.
- Set the function with the SD Manager 3, restore the settings to the F3SG-SR, and perform wiring according to the wiring diagram.
- This wiring example shows light emission stop when connected to 24 VDC with PNP setting, and light emission stop when connected to 0 VDC with NPN setting. If TEST switch is not needed, refer to 2-6. *External Test*.

Timing chart

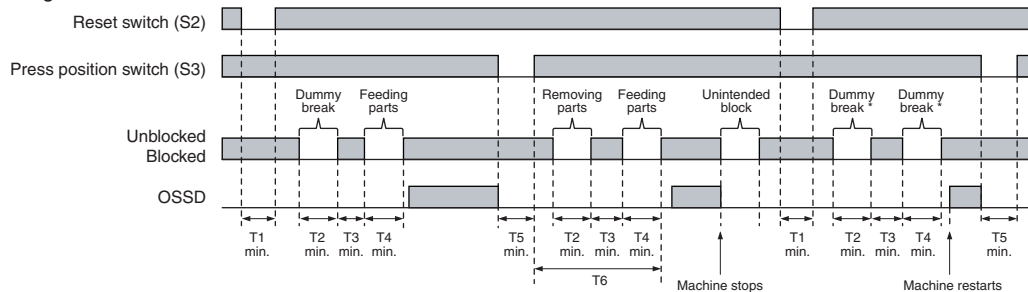

T1: Minimum pressing time of reset switch. Configurable from 100 to 500 ms in 100-ms increments by SD Manager 3.
 T2: Minimum break time (300 ms)
 T3: Minimum unblocked time during the time from removing to feeding parts. T3 = T1
 T4: Minimum break time (300 ms)
 T5: Minimum pressing time of press position switch. T5 = T1
 T6: Wait time until double break is complete (30 s or less)

* When the machine is stopped by unintended block in the middle of pressing of parts, operation of the reset switch (S1) and then double dummy break are needed for reinitiation of the machine cycle.



When a functional earth is necessary, wire an earth cable according to the example in 6-2-1-1. *Auto Reset Mode with Optical Synchronization and EDM Unused*. Also refer to 5-4-4. *Functional Earth Connection* for more information.

6-2-2. Muting System Wiring Examples

6-2-2-1. Standard Muting Mode/Exit-Only Muting Mode

F3SG-SRA	✓	F3SG-PGA-A/-L	✓
F3SG-SRB	✓	F3SG-PGA-C	✓*11

[Wiring Example (F3SG-SR and F3SG-PGA-A/-L*11)]

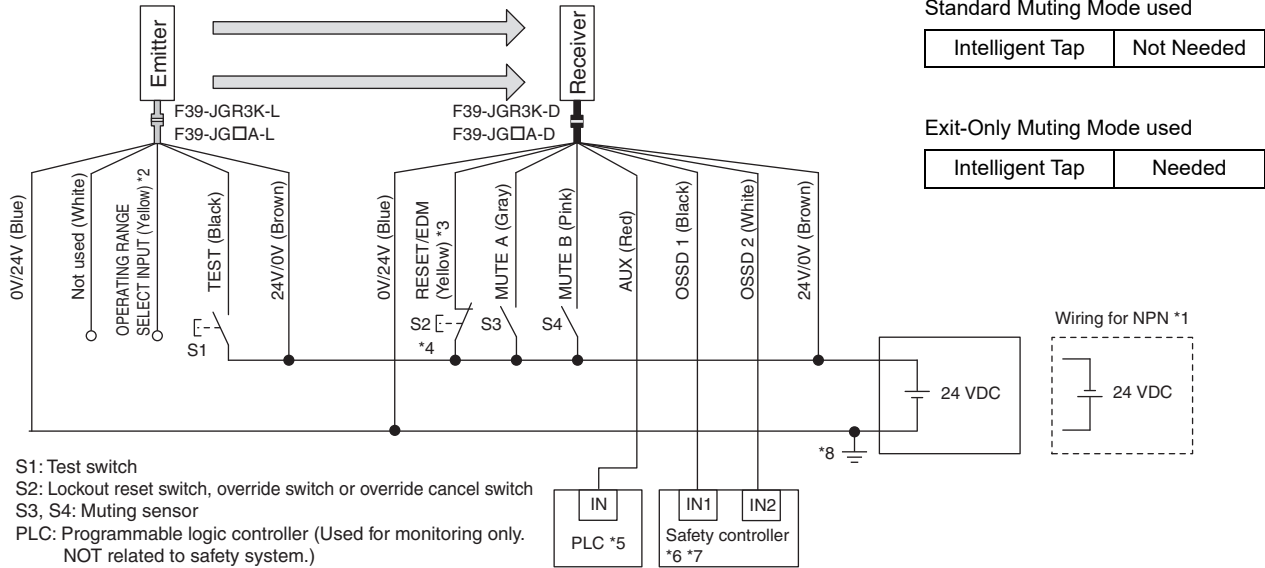

Function	Setting	
	DIP switch	SD Manager 3
EDM	EDM Disabled (factory default setting)	[External device monitoring] : Disable *9
Interlock	Auto Reset (factory default setting)	[Start interlock] : Disable [Restart interlock] : Disable *9
Operating Range Selection	Long : Open the OPERATING RANGE SELECT INPUT line of the emitter or connect the line to 24 VDC.	
Standard Muting Mode	When not using the Intelligent Tap or the SD Manager 3, perform wiring according to the wiring diagram. (factory default setting)	[Muting] : Enable [Muting mode] : Standard Muting (Installation Example 1/2) *9
Exit-Only Muting Mode	N/A	[Muting] : Enable [Muting mode] : Exit-Only Muting *9
External Test used*12	Connect the TEST line of the emitter to 24V/0V of the emitter via a test switch (NO contact). *10	[External test signal inversion] : Disable
Optical Synchronization	Do not connect the communication lines of the emitter and receiver with each other.	

Timing chart

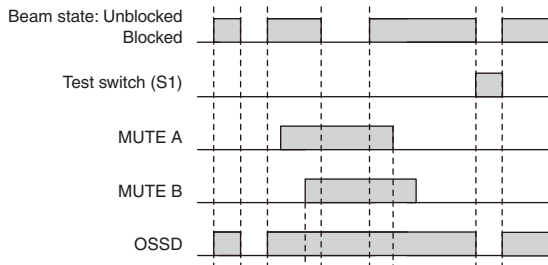

- *1. Reverse the polarity of the power supply when using in the NPN system. Select a PLC and a safety controller of PNP or NPN type according to the system of your application.
- *2. Connect the line to 0 VDC if F3SG-SR or F3SG-PGA-L is used in Short Mode. F3SG-PGA-A/-C does not support the Operating Range Selection function.
- *3. Also used as OVERRIDE INPUT line.
- *4. Make sure to connect an override cancel switch to the RESET line when using the override function. Otherwise the override state may not be released by the override cancel switch, resulting in serious injury.
- *5. When connecting to the PLC, the output mode must be changed with the SD Manager 3 according to your application. Refer to *Chapter 4 Setting with SD Manager 3* for more information on setting this function by the SD Manager 3.
- *6. Refer to 6-3. *Connectable Safety Controllers* for more information.
- *7. The safety controller and the F3SG-SR/PG must share the power supply or be connected to the common terminal of the power supply.
- *8. This is the case for a PELV circuit.
- *9. Set the function with the SD Manager 3, restore the settings to the F3SG-SR/PG, and perform wiring according to the wiring diagram.
- *10. This wiring example shows light emission stop when connected to 24 VDC with PNP setting, and light emission stop when connected to 0 VDC with NPN setting. If TEST switch is not needed, refer to 2-6. *External Test*.
- *11. To use F3SG-PGA-C, wire the receiver side of the emitter/receiver of F3SG-PGA-C as shown in the above figure. Wiring of the emitter side is not needed.
- *12. F3SG-PGA-C does not support the External Test function.



- When a functional earth is necessary, wire an earth cable according to the example in 6-2-1-1. *Auto Reset Mode with Optical Synchronization and EDM Unused*. Also refer to 5-4-4. *Functional Earth Connection* for more information.

6-2-2-2. Standard Muting Mode/Exit-Only Muting Mode with Y-Joint Plug

F3SG-SRA	✓	F3SG-PGA-A/-L	✓
F3SG-SRB	✓	F3SG-PGA-C	

[Wiring Example (F3SG-SR and F3SG-PGA-A/-L)]

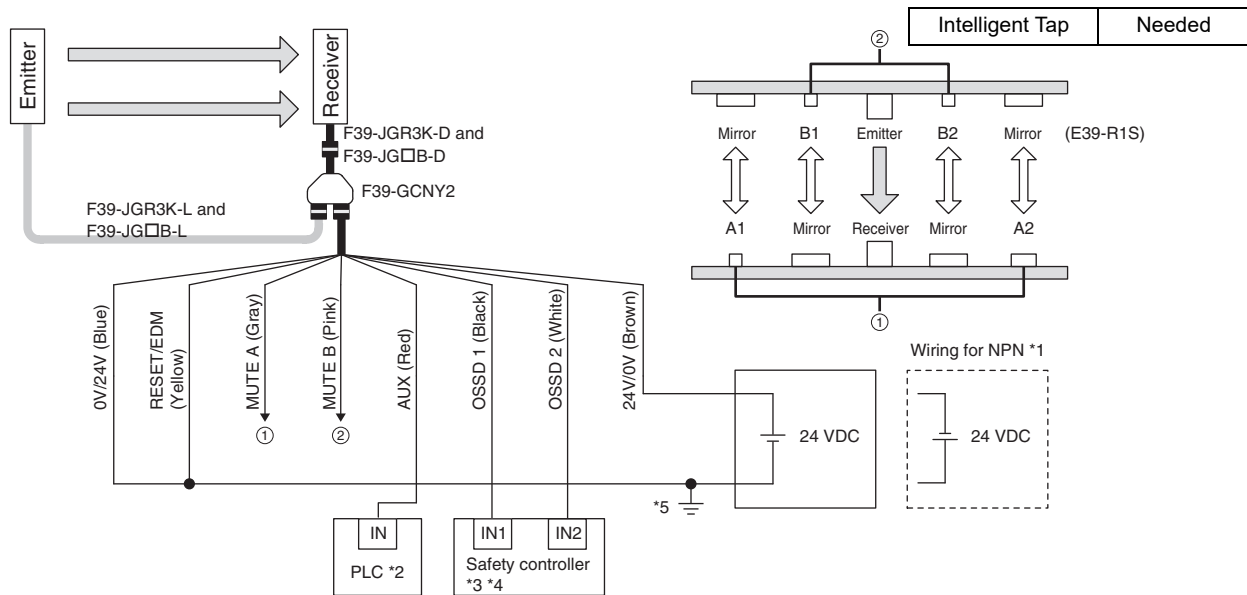

PLC: Programmable logic controller (Used for monitoring only. NOT related to safety system.)
 A1, A2, B1, B2: Muting sensor (E3Z-R□6)

Function	Setting	
	DIP switch	SD Manager 3
EDM	EDM Disabled (factory default setting)	[External device monitoring] : Disable *6
Interlock	Auto Reset (factory default setting)	[Start interlock] : Disable [Restart interlock] : Disable *6
Operating Range Selection	Long (factory default setting)	
Standard Muting Mode	When not using the Intelligent Tap or the SD Manager 3, perform wiring according to the wiring diagram. N/A	[Muting] : Enable [Muting mode] : Standard Muting (Installation Example1/2) *6
Exit-Only Muting Mode	N/A	[Muting] : Enable [Muting mode] : Exit-Only Muting *6
External Test not used	N/A	
Optical Synchronization	Connect the wires according to the diagram above.	

Timing chart

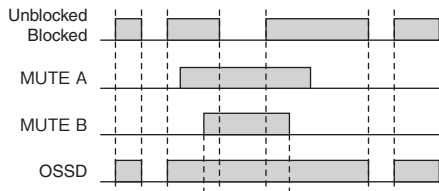

- *1. Reverse the polarity of the power supply when using in the NPN system. Select a PLC and a safety controller of PNP or NPN type according to the system of your application.
- *2. When connecting to the PLC, the output mode must be changed with the SD Manager 3 according to your application. Refer to *Chapter 4 Setting with SD Manager 3* for more information on setting this function by the SD Manager 3.
- *3. Refer to 6-3. *Connectable Safety Controllers* for more information.
- *4. The safety controller and the F3SG-SR/PG must share the power supply or be connected to the common terminal of the power supply.
- *5. This is the case for a PELV circuit.
- *6. When using the Exit-Only Muting, set the function with the SD Manager 3, restore the settings to the F3SG-SR, and perform wiring according to the wiring diagram.



- When using the Y-Joint Plug/Socket Connector (F39-GCNY2), the following functions are not available.
 - External Test
 - Operating Range Selection
 - Wired Synchronization
- When a functional earth is necessary, wire an earth cable according to the example in 6-2-1-1. *Auto Reset Mode with Optical Synchronization and EDM Unused*. Also refer to 5-4-4. *Functional Earth Connection* for more information.

6-2-2-4. Standard Muting Mode/Exit-Only Muting Mode with Reset Switch Connector

F3SG-SRA	✓	F3SG-PGA-A/-L	✓
F3SG-SRB	✓	F3SG-PGA-C	✓*8

[Wiring Example (F3SG-SR and F3SG-PGA-A/-L *8)]

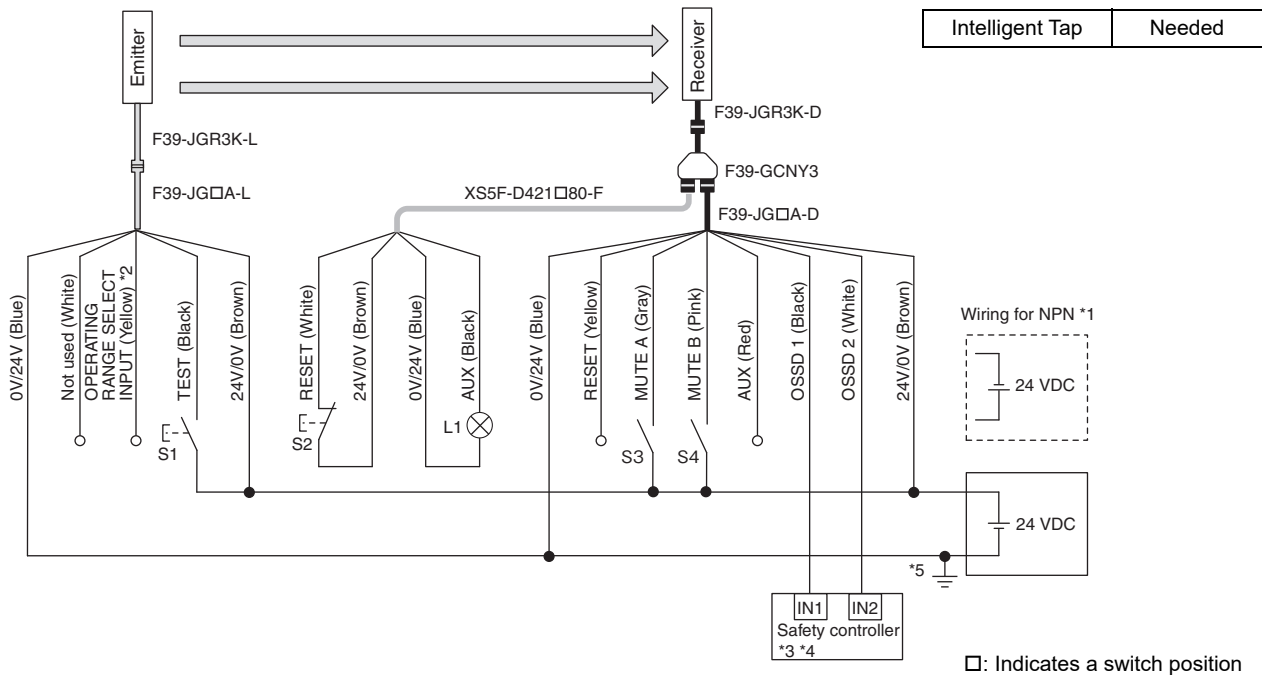

Function	Setting	
	DIP switch	SD Manager 3
EDM	EDM Disabled (factory default setting)	
Interlock *6	Manual Reset 4 <input checked="" type="checkbox"/> ON 5 <input checked="" type="checkbox"/> ON	[Start interlock] : Enable [Restart interlock] : Enable
Operating Range Selection	Long : Open the OPERATING RANGE SELECT INPUT line of the emitter or connect the line to 24 VDC.	
Standard Muting Mode	N/A	[Muting] : Enable [Muting mode] : Standard Muting (Installation Example 1/2) *6
Exit-Only Muting Mode *6	N/A	[Muting] : Enable [Muting mode] : Exit-Only Muting *6
External Test used *9	Connect the TEST line of the emitter to 24V/0V via a test switch (NO contact). *7	
	N/A	[External test signal inversion] : Disable
Optical Synchronization	Open the COM(+) and COM(-) lines of the emitter.	

- S1: Test switch
- S2: Lockout/interlock reset switch
- S3: S4: Muting sensor
- L1: Lamp

Timing chart

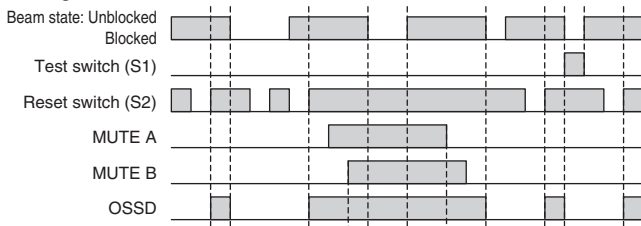

- *1. Reverse the polarity of the power supply when using in the NPN system. Select a safety controller of PNP or NPN type according to the system of your application.
- *2. Connect the line to 0 VDC if F3SG-SR or F3SG-PGA-L is used in Short Mode. F3SG-PGA-A/-C does not support the Operating Range Selection function.
- *3. Refer to 6-3. *Connectable Safety Controllers* for more information.
- *4. The safety controller and the F3SG-SR/PG must share the power supply or be connected to the common terminal of the power supply. This is the case for a PELV circuit.
- *5. This is the case for a PELV circuit.
- *6. Set the function with the DIP Switches on the Intelligent Tap or the SD Manager 3, restore the settings to the F3SG-SR, and perform wiring according to the wiring diagram.
- *7. This is the example for the PNP system to stop emission when the line is connected to 24 VDC and for the NPN to stop emission when the line is connected to 0 VDC. If TEST switch is not needed, refer to 2-6. *External Test*.
- *8. To use F3SG-PGA-C, wire the receiver side of the emitter/receiver of F3SG-PGA-C as shown in the above figure. Wiring of the emitter side is not needed.
- *9. F3SG-PGA-C does not support the External Test function.



- When using the Reset Switch Connector (F39-GCNY3), the following functions are not available.
- External Device Monitoring (EDM)
- When a functional earth is necessary, wire an earth cable according to the example in 6-2-1-1. *Auto Reset Mode with Optical Synchronization and EDM Unused*. Also refer to 5-4-4. *Functional Earth Connection* for more information.

6-3. Connectable Safety Controllers

The F3SG-SR/PG in the PNP system can be connected to the safety controllers listed in the table below.

Connectable safety controllers (PNP output)		
G9SA-301	G9SX-AD322-T	G9SP-N10S
G9SA-321-T□	G9SX-ADA222-T	G9SP-N10D
G9SA-501	G9SX-BC202	G9SP-N20S
G9SB-200-B	G9SX-GS226-T15	NE0A-SCPU01
G9SB-200-D		NE1A-SCPU01
G9SB-301-B		NE1A-SCPU02
G9SB-301-D		DST1-ID12SL-1
G9SE-201		DST1-MD16SL-1
G9SE-401		DST1-MRD08SL-1
G9SE-221-T□		NX-SIH400
F3SP-T01		NX-SID800
		GI-SMD1624
		GI-SID1224

The F3SG-SR/PG in the NPN system can be connected to the safety controller listed in the table below.

Connectable safety controller (NPN output)
G9SA-301-P

For the connection to IO-Link with the Intelligent Tap, the F3SG-SR/PG can be connected to the IO-Link Master unit listed in the table below.

Connectable IO-Link Master units*
NX-ILM400
GX-ILM08C

* Connectable to units supporting IO-Link Version 1.1.

Chapter 7 Checklists

7-1. Pre-Operation Checklists	420
<hr/>	
7-1-1. Checklists	420
<hr/>	
7-1-1-1. Installation Condition Check	420
7-1-1-2. Wiring Check Before Power Is Turned ON	420
7-1-1-3. Operation Check While the Machine Is Stopped	421
7-1-1-4. Checking that Hazardous Parts Stop While the Machine Operates	422
7-2. Maintenance Checklists	423
<hr/>	
7-2-1. Checklists	423
<hr/>	
7-2-1-1. Inspection at Startup and When Changing Operators	423
7-2-1-2. Checking that Hazardous Parts Stop While the Machine Operates	424
7-2-1-3. Items to Inspect Every 6 Months or When Machine Settings Are Changed	424

7-1. Pre-Operation Checklists

WARNING

Make sure Responsible Person tests the operation of the F3SG-SR/PG and F39-SGIT-IL3 after installation to verify that the F3SG-SR/PG and F39-SGIT-IL3 operate as intended. Make sure to stop the machine until the test is complete. Unintended installation, wiring or function settings may cause a person to go undetected, resulting in serious injury.



After installation, the highest level administrator must use the following checklist to verify the operation, placing a check mark in each of the boxes.

7-1-1. Checklists

7-1-1-1. Installation Condition Check

- The machine itself does not prevent the operation of safety functions such as stopping.
- The hazardous part of a machine cannot be reached without passing through the detection zone of the F3SG-SR/PG.
- The system is configured so that the F3SG-SR/PG can always detect a worker who is working in the hazardous zone.
- The interlock reset switch is installed in a location that provides a clear view of the entire hazardous zone and it cannot be activated from within the hazardous zone.
- The pre-reset switch is installed in a location inside the hazardous zone and where it cannot be operated from outside the hazardous zone.
- Safety distance has been calculated. Calculated distance: $S = (\quad)\text{mm}$
- Safety distance has been calculated with larger object resolution when the Floating Blanking or Reduced Resolution function is used.
Calculated distance: $S = (\quad)\text{mm}$
- The actual distance is equal to or greater than the calculated distance. Actual distance = $(\quad)\text{mm}$
- Reflective surfaces are not installed in prohibited zones.
- Not installed in a retro-reflective configuration.
- When the Muting function is used, a muting sensor must be installed so that MUTING state should not occur when a human body enters a detection zone of the F3SG-SR/PG by mistake.
- When the Muting function is used, a muting sensor must be installed so that MUTING state should not occur when a human body enters a hazardous zone of a machine.
- When the Muting function is used, MUTING state can be checked from where a worker operates or adjust the machine.
- A muting sensor consists of two independent devices.
- It is not used in flammable or explosive atmosphere.

7-1-1-2. Wiring Check Before Power Is Turned ON

- When the power supply unit is connected to multiple devices, the power supply unit must have tolerance against total rated current of the devices.
- The power supply unit is a 24 VDC unit that conforms to the EMC Directive, Low-voltage Directive, and output holding time specifications.
- The power supply lines are wired with a proper polarity according to the wiring specifications of the PNP or NPN setting.
- Emitter/receiver cables are properly connected to the respective emitters/receivers.
- Double insulation is used between I/O lines and the hazard potential (commercial power supplies, etc.).

- When using PNP output, the outputs are not short-circuited to +24 VDC line. When using NPN output, the outputs are not short-circuited to 0 VDC line.
- When using PNP output, loads are not connected to +24 VDC line. When using NPN output, loads are not connected to 0 VDC line.
- All lines are not connected to commercial power source.
- When using the F3SG-SR, the root cable must not be attached to the connector for the Cascading Cable and vice versa.
- Model of emitter and receiver must be the same.
- When two or more F3SG-SR systems are used, they are in cascade connection or prevented from mutual interference with each other.
- On a secondary sensor farthest from its power supply, the following part is attached:
 - End Cap
- Neither connector, cap, or bracket must be loose.
- Auxiliary output must not be used as safety output.
- When using PNP output, +24 VDC line of the power supply must not be grounded. When using NPN output, 0 VDC line of the power supply must not be grounded.
- Wiring must not be bent, cracked, nor damaged.

7-1-1-3. Operation Check While the Machine Is Stopped

- The test rod is not deformed.
The object resolution may vary depending on the models of the F3SG-SR and settings of the Floating Blanking function or Reduced Resolution function. Use a test rod with an appropriate diameter for inspection. A test rod is not included in the F3SG-SR product package. The model name of test rod is as follows.

Model name	Diameter *
F39-TRD14	Dia. 14 mm
F39-TRD25	Dia. 25 mm
F39-TRD30	Dia. 30 mm

* The customer needs to prepare a test rod larger than 30-mm dia.

- The F3SG-SR must detect a test rod wherever it is in the detection zone. In other words, when a test rod is inserted into the detection zone, the OSSD indicator turns red.
The F3SG-PG detects the test rod when the test rod is moved on the optical axis. That is, when the test rod is moved from the sensor end to the sensor end, the OSSD indicator light turns red only by the number of optical axes.
When the Fixed Blanking function is used, you must ensure that all blanked zones in the detection zone are covered by a hard barrier guard and there must be no zone in the detection zone where the test rod goes undetected.

To check detection, move the test rod as shown in the diagram below.

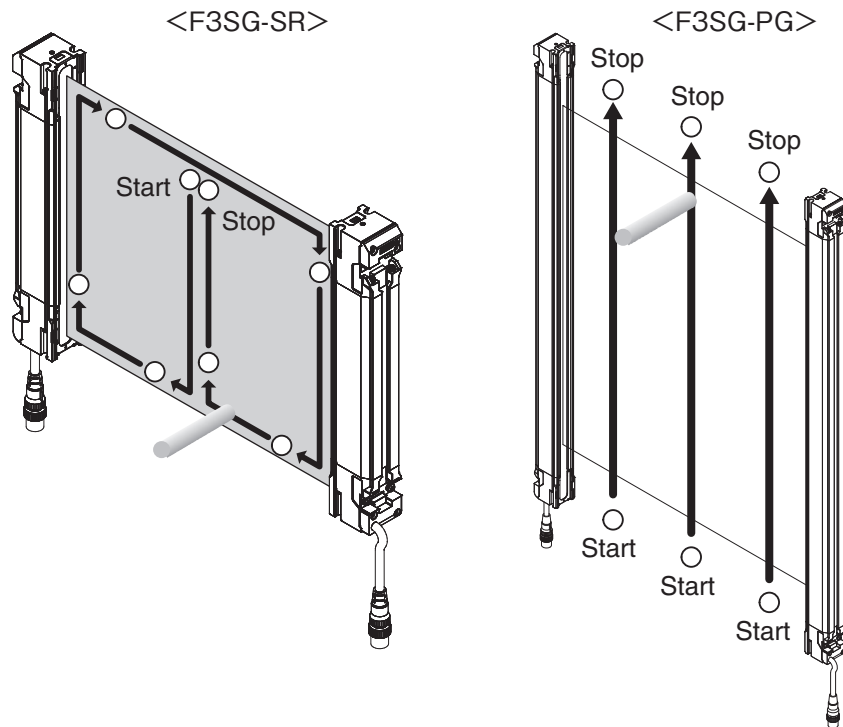

- When the External Test function is used:
When PNP is selected, the OSSD indicator turns red when the TEST line is short-circuited to 9 V to Vs.
When NPN is selected, the OSSD indicator turns red when the TEST line is short-circuited to 0 to 3 V.
- When the External Device Monitoring function is used:
When the RESET line is open the OSSD indicator remains red regardless of the beam state of the F3SG-SR/PG.
- When the Start Interlock function is used:
When the F3SG-SR/PG is turned ON and the F3SG-SR/PG is unblocked, the OSSD indicator remains red. The reset input turns the OSSD indicator to green.
- When the Restart Interlock function is used:
When the OSSD indicator is green and the F3SG-SR/PG is blocked and then returned to unblocked state, the OSSD indicator remains red. The reset input turns the OSSD indicator to green.
- When the Muting function is used, minimum muting time limit required must be set.
- When the Muting function's operation mode is Exit-Only Muting mode, minimum muting end wait time required must be set.
- Under the MUTING state, a signal that indicates the MUTING state must be given from the AUX line.
- When the Override function is used, the minimum override time limit required must be set.
- Under the OVERRIDE state, a signal that indicates the OVERRIDE state must be given from the AUX line.

7-1-1-4. Checking that Hazardous Parts Stop While the Machine Operates

- The hazardous parts stop immediately when a test rod is inserted into the detection zone at 3 positions: "directly in front of the emitter", "directly in front of the receiver", and "between the emitter and receiver". (Use the appropriate test rod.)
- The hazardous parts remain stopped as long as the test rod is in the detection zone.
- The hazardous parts stop when the power of the F3SG-SR/PG is turned OFF.
- The actual response time of the whole machine is equal to or less than the calculated value.
- The setting of operating range is as intended.

7-2. Maintenance Checklists

WARNING

Perform daily and 6-month inspections for all F3SG-SR/PG. When using the F3SG-SR/PG in cascade connection, perform inspections for every connected F3SG-SR/PG. Otherwise, the system may fail to work properly, resulting in serious injury.



Do not try to disassemble, repair, or modify the product. Doing so may cause the safety functions to stop working properly.



To ensure safety, keep a record of the inspection results.

When the user is a different person from those who installed or designed the system, he/she must be properly trained for maintenance.

7-2-1. Checklists

7-2-1-1. Inspection at Startup and When Changing Operators

- There is no approach route other than through the detection zone of the F3SG-SR/PG.
- Part of the operator's body always remains in the detection zone of the F3SG-SR/PG when working around the machine's hazardous part.
- The actual safety distance is equal to or greater than the calculated value.
- There must be no dirt on or damage to the front window or Spatter Protection Cover (F39-HSG, sold separately) of the F3SG-SR/PG.
- When PNP is selected, the OSSD indicator turns red when the TEST line is short-circuited to 9 V to Vs. When NPN is selected, the OSSD indicator turns red when the TEST line is short-circuited to 0 to 3 V.
- When muting lamp is used, a muting lamp must be clear and free of dirt or degradation.
- The test rod is not deformed.
- When the Start Interlock function is used:
When the F3SG-SR/PG is turned ON and the F3SG-SR/PG is unblocked, the OSSD indicator remains red. The reset input turns the OSSD indicator to green.
- When the Restart Interlock function is used:
When the OSSD indicator is green and the F3SG-SR/PG is blocked and then returned to unblocked state, the OSSD indicator remains red. The reset input turns the OSSD indicator to green.
- When the power of the F3SG-SR/PG is turned ON while nothing is in the detection zone, it must operate as follows:
If Start Interlock is not used: The OSSD indicator turns green within 3 s after the F3SG-SR/PG is turned ON.
If Start Interlock is used: The SEQ indicator turns yellow and the OSSD indicator turns red within 3 s after the F3SG-SR/PG is turned ON.
- Nothing should exist in the detection zone and the OSSD indicator must turn ON (red or green) at power on.

- The test rod is detected when it is moved around in the detection zone as shown in the diagram below. In other words, when a test rod is inserted into the detection zone, the OSSD indicator turns red. The F3SG-PG detects the test rod when the test rod is moved on the optical axis pitch. That is, when the test rod is moved from the sensor end to the sensor end, the OSSD indicator light turns red only by the number of optical axes.
- When the Fixed Blanking function is used, you must ensure that all blanked zones in the detection zone are covered by a hard barrier guard and there must be no zone in the detection zone where the test rod goes undetected.
- The object resolution may vary depending on the models of the F3SG-SR and settings of the Floating Blanking function or Reduced Resolution function. Use a test rod with an appropriate diameter for inspection. A test rod is not included in the F3SG-SR product package.

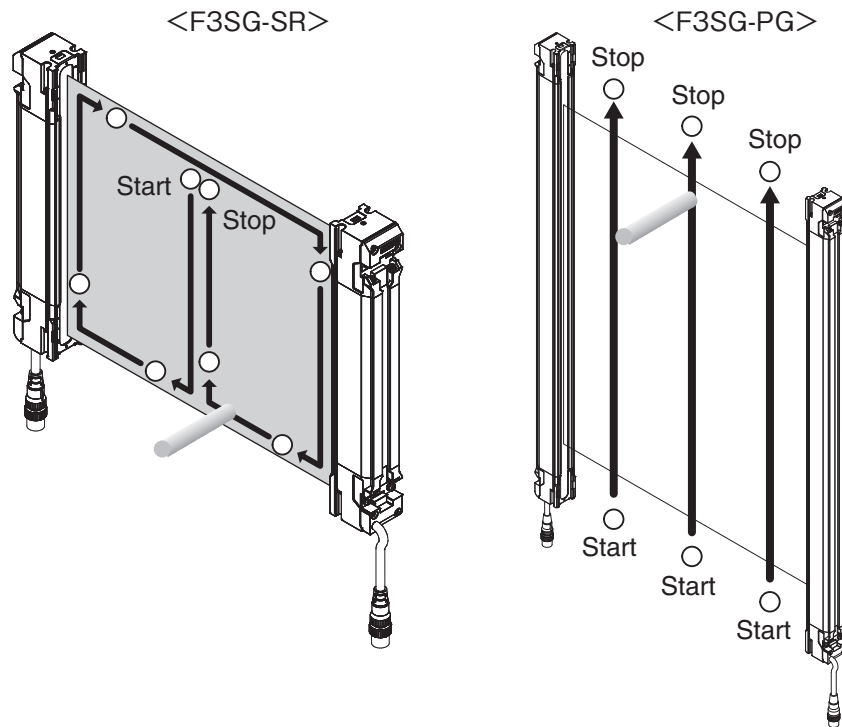

- When the Muting function is used, installation condition of muting sensor must not be changed.
- When the Muting function is used, the MUTING state can be checked from where a worker operates or adjust the machine.
- Neither connector, cap, or bracket must be loose.

7-2-1-2. Checking that Hazardous Parts Stop While the Machine Operates

- The hazardous parts are movable when nothing is in the detection zone.
- The hazardous parts stop immediately when a test rod is inserted into the detection zone at 3 positions: "directly in front of the emitter", "directly in front of the receiver", and "between the emitter and receiver". (Use the appropriate test rod.)
- The hazardous parts remain stopped as long as the test rod is in the detection zone.
- The hazardous parts stop when the power of the F3SG-SR/PG is turned OFF while nothing is in the detection zone.

7-2-1-3. Items to Inspect Every 6 Months or When Machine Settings Are Changed

In addition to inspection item at operation start, following items must also be verified.

- The outputs of the F3SG-SR/PG and the machine are properly wired.
- The total number of times that the control relays/contactors have switched is significantly lower than their design lives.
- There is no ambient light.

- Safety distance has been calculated with changed object resolution when the setting of the Floating Blanking or Reduced Resolution function is changed.
Calculated distance: $S = (\quad)\text{mm}$
- When the Muting function setting is changed, a muting sensor must be installed so that the MUTING state should not occur when a human body enters a detection zone of F3SG-SR/PG by mistake.
- When the Muting function setting is changed, a muting sensor must be installed so that the MUTING state should not occur when a human body enters a hazardous zone of a machine.
- When the Muting function setting is changed, a muting sensor must consist of 2 independent devices.
- When the configuration of the cascade connection is changed, the following part is attached on a secondary sensor farthest from its power supply:
 - End Cap
- When using PNP output, +24 VDC line of the power supply must not be grounded. When using NPN output, 0 VDC line of the power supply must not be grounded.
- Wiring must not be bent, cracked, nor damaged.

Chapter 8 Appendix

8-1. Troubleshooting	428
8-1-1. LED Indicators	428
8-1-2. LOCKOUT State	430
8-1-2-1. Description	430
8-1-2-2. Troubleshooting	431
8-1-3. Warning	437
8-1-3-1. Description	437
8-1-3-2. Troubleshooting	431
8-1-3-3. Muting Sequence Error Indication	438
8-1-3-4. Interlock Sequence Error Indication	439
8-1-3-5. PSDI Sequence Error Indication	440
8-1-4. Troubleshooting for Intelligent Tap	441
8-1-5. Troubleshooting for Bluetooth® Communication Unit	444
8-2. Optional Accessories (Sold Separately)	445
8-3. Glossary	457
8-4. Revision History	461

8-1. Troubleshooting

8-1-1. LED Indicators

■ F3SG-SR Series

<Emitter>

F3SG-□SR□□□□□□-14

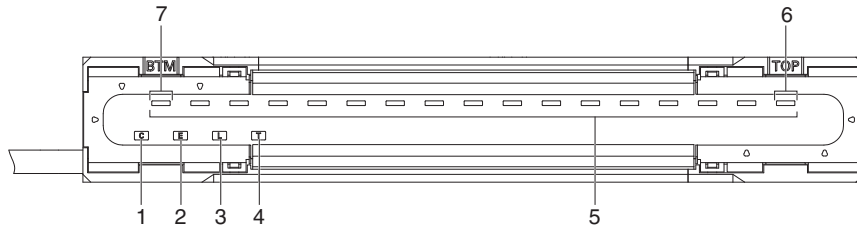

F3SG-□SR□□□□□□-25/-45/-85

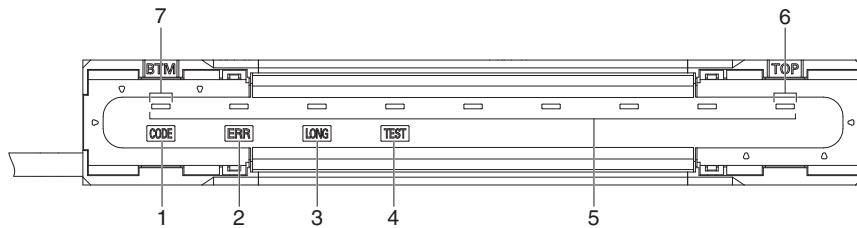

1	Scan code
2	Lockout
3	Operating range
4	Test
5	Area Beam Indicator (ABI) *1
6	Top-beam-state *2
7	Bottom-beam-state *2

<Receiver>

F3SG-□SR□□□□□□-14

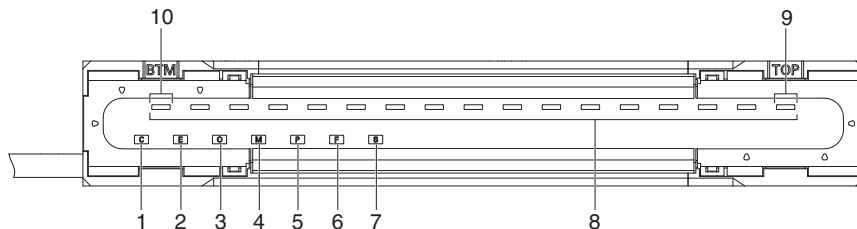

F3SG-□SR□□□□□□-25/-45/-85

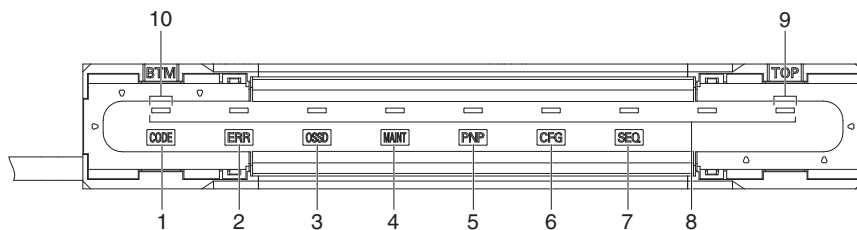

1	Scan code
2	Lockout
3	ON/OFF
4	Maintenance
5	PNP/NPN mode
6	Configuration
7	Sequence
8	Area Beam Indicator (ABI) *1
9	Top-beam-state *2
10	Bottom-beam-state *2

*1. For the F3SG-□SRA only.

*2. For the F3SG-□SRB only.

■ F3SG-PGA-A/-L Series

<Emitter>

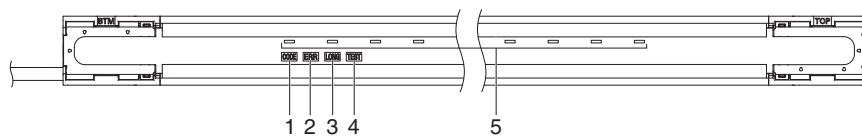

1	Scan code
2	Lockout
3	Operating range
4	Test
5	Area Beam Indicator (ABI)

<Receiver>

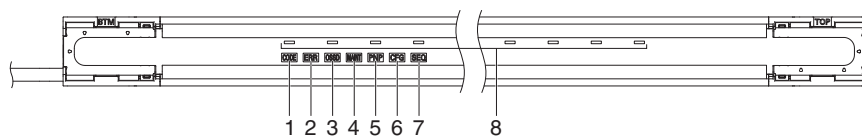

1	Scan code
2	Lockout
3	ON/OFF
4	Maintenance
5	PNP/NPN mode
6	Configuration
7	Sequence
8	Area Beam Indicator (ABI)

■ F3SG-PGA-C Series

<Emitter/Receiver>

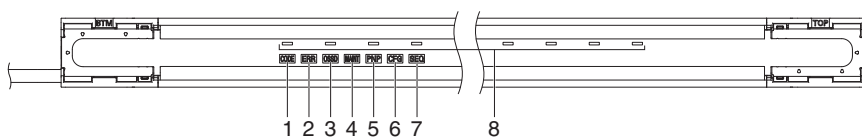

1	Scan code
2	Lockout
3	ON/OFF
4	Maintenance
5	PNP/NPN mode
6	Configuration
7	Sequence
8	Area Beam Indicator (ABI)

LED Blinking Pattern:

The timing chart below shows the blinking frequency of the LED blinking patterns (blinking once through seven times) described in the following pages.

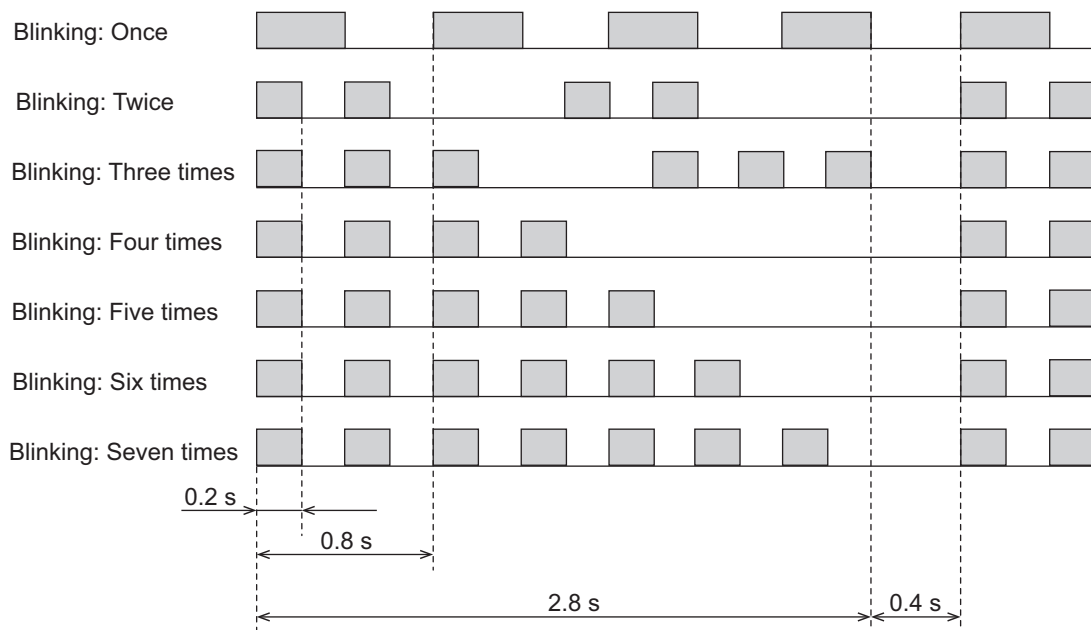

You can check error and warning logs by the Maintenance Information function using the SD Manager 3 or the SD Manager 3 Mobile APP.

 Refer to *Chapter 4 Setting with SD Manager 3* for more information on checking error and warning logs by the SD Manager 3 or the SD Manager 3 Mobile APP.

8-1-2. LOCKOUT State

8-1-2-1. Description

If the F3SG-SR/PG detects any failure, it keeps the safety outputs in the OFF state and transitions to the LOCKOUT state. Under the LOCKOUT state, the ERR indicator blinks and other indicators blink based on the failure. Solve the problems based on the table below.

Eliminate the cause of the problem. Then turn the power ON again or reset the LOCKOUT state by providing a reset input to restart the F3SG-SR/PG.

8-1-2-2. Troubleshooting

Identify an error according to the combination of the indicators when the error occurs. See the following troubleshooting tables to take measures.

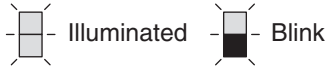

<Indicator status at lockout: Receiver and Emitter/Receiver>

Combination of indicators and error description

ERR indicator	MAINT indicator	Other indicators	Error description
 Blinking once	 [Error description] Recoverable error Red blinking : Replacement-recommended error	 Safety Output error	
		 Error due to change of PNP/NPN polarity during operation	
		 Blanking monitoring error Configuration error Parameter error	
		TOP *1 Cap error Other sensor error	
		BTM *2 DIP Switch setting error	
 Blinking twice		 Safety output error due to power supply voltage or noise	
 Blinking once		— Communication error External device monitoring error Error other than those above	
—	 Orange blinking	—	Intelligent Tap error
 Illuminated	— *3	— *3	Lockout of some other sensor is detected.*4

*1. For F3SG-SRA and F3SG-PG, the Area Beam Indicator closer to the "TOP" mark on the F3SG-SR/PG blinks.





*2. For F3SG-SRA and F3SG-PG, the Area Beam Indicator closer to the "BTM" mark on the F3SG-SR/PG blinks.

*3. May be turned ON or blink depending on the sensor's state.

*4. If the sensor is F3SG-SR or F3SG-PGA-L/A, some other connected sensor is in lockout state. Check the other connected sensors to confirm the combination of the indicators of the sensor whose ERR indicator is blinking. For F3SG-PGA-C, use SD Manager 3 to confirm the error code.

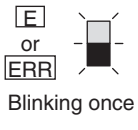
<Indicator status at lockout: Emitter>

Combination of indicators and error description

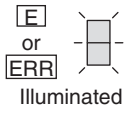

ERR indicator	Other indicators	Error description
 Blinking once		Operating range selection setting error
	TOP *1 	Cap error Other sensor error
	BTM *2 	DIP Switch setting error
	—	Communication error Error other than those above
 Illuminated	— *3	Lockout of some other sensor is detected.*4

- *1. For F3SG-SRA and F3SG-PGA-A/-L, the Area Beam Indicator closer to the "TOP" mark on the F3SG-SR/PG blinks.
- *2. For F3SG-SRA and F3SG-PGA-A/-L, the Area Beam Indicator closer to the "BTM" mark on the F3SG-SR/PG blinks.
- *3. May be turned ON or blink depending on the sensor's state.
- *4. If the sensor is F3SG-SR or F3SG-PGA-L/-A, some other connected sensor is in lockout state. Check the other connected sensors to confirm the combination of the indicators of the sensor whose ERR indicator is blinking. For F3SG-PGA-C, use SD Manager 3 to confirm the error code.

Description	Checking by		Error code (hex)*1	Cause and measures
	Indicator	SD Manager 3/ SD Manager 3 Mobile APP		
Safety output error	X	X	60, 6B, 6C	The OSSD lines may be short-circuited to each other or another signal line may be short-circuited to the OSSD line. Wire the OSSD lines properly.  Chapter 5 Wiring and Installation
			56	The polarity does not match between the power supply and the OSSD lines. Check if a correct polarity is selected for the PNP/NPN setting according to your application. Also check: • if the power supply (0 VDC or 24 VDC) of the Intelligent Tap and F3SG-SR/PG is wired as intended. • if the OSSD lines are properly wired.
Recoverable error	X	-	-	The error may occur due to a temporary cause. Identify the cause by the status of the other LED indicator and take measures.
Replacement-recommended error				The error may occur due to a product failure. If the measure according to the status of the other LED indicator does not work, it is recommended to replace the F3SG-SR/PG.
Intelligent Tap error	X	- *2	- *2	An error due to noise may have occurred in the internal circuit of the Intelligent Tap. Check the noise level in the environment.
				The internal circuit of the Intelligent Tap may be defective. Replace the Intelligent Tap.
Error due to change of PNP/NPN polarity during operation	X	X	E7	An error due to noise may have occurred in the internal circuit. Check the noise level in the environment.
				The internal circuit may be defective. Replace the F3SG-SR/PG.
Blanking monitoring error	X	X	EC	An error is detected by the Fixed Blanking Monitoring function or the Floating Blanking Monitoring function. See Chapter 2 "Fixed Blanking" or "Floating Blanking" to solve the problem.  2-15. Fixed Blanking  2-16. Floating Blanking
Configuration error	X	X	39, 3A, 3B	The cascading cable may be short-circuited, broken, or disconnected. Check that the cascading cable should be tightly connected. If the cascading cable is broken, replace it. The number of connected sensors or beams may have exceeded the maximum value due to cascading. Check the configuration.
			3C, 3E, 3F	A model name does not match between emitter and receiver. Check that the emitter and receiver are the same model.

Description	Checking by		Error code (hex)*1	Cause and measures
	Indicator	SD Manager 3/ SD Manager 3 Mobile APP		
Configuration error	X	X	34	<p>An error may have occurred to the internal information of the model name of the F3SG-SR/PG due to effect of noise.</p> <p>If other devices using the same power supply generate noise, do not share the same power supply with other devices, and use a separate power supply exclusively for the safety components.</p> <p>The inductive noise tends to be induced especially if the power supply line of the machine guarded and the power supply line of the Intelligent Tap are arranged in parallel. Arrange the exclusive power supply near the Intelligent Tap or lay the power supply line of the Intelligent Tap away from the power supply line of the machine guarded.</p> <p>If the power supply for the Intelligent Tap is located near the power supply of the machine guarded and it shares the same grounding wire, it is subject to the influence of common mode noise.</p> <p>Separate the grounding point or use it as the exclusive ground.</p> <p> 5-4-4. Functional Earth Connection</p>
				<p>An error may have occurred in the internal circuit. Replace the F3SG-SR/PG.</p>
Parameter error	X	X	F1	The settings do not match between the Intelligent Tap and F3SG-SR/PG. Perform the Backup.
			40	The settings of the F3SG-SR/PG may be faulty. Check if the settings are correct.
Cap error	X	X	4F	A cap may be detached. Attach the cap properly.
Other sensor error	X	X	38	Other sensor being cascaded caused an error. Check the indicator of the sensor.
DIP Switch setting error	X	X	E7, E8	<p>A DIP Switch on the Intelligent Tap setting may have been changed during operation. Check if a DIP Switch setting was changed or not.</p>
				<p>The internal circuit of the Intelligent Tap may be defective. Replace the Intelligent Tap.</p>
Communication error	-	X	30, 32	<p>The communication lines or other lines may be short-circuited or broken.</p> <p>Check if the cascading or extension cables. If the cascading cable or extension cables is broken, replace it.</p>
				31
			<p>An error may have occurred in the internal circuit. Replace the F3SG-SR/PG.</p>	

Description	Checking by		Error code (hex)*1	Cause and measures
	Indicator	SD Manager 3/ SD Manager 3 Mobile APP		
Safety output error due to power supply voltage or noise	X	X	19	<p>The power supply voltage may have dropped temporarily when the F3SG-SR/PG is in operation. Check for temporary power supply voltage drop (by about 12 VDC) by the influence of the inductive load, etc. If the exclusive power supply is not used, check the power consumption of other connected devices for enough capacity.</p> <p>Power supply voltage may be outside the rated range. Connect the F3SG-SR/PG to a 24 VDC±20% power supply voltage.</p> <p>Voltage fluctuation may have occurred due to insufficient power supply capacity. Replace the power supply with one that has a larger capacity.</p> <p>Instantaneous break or instantaneous stop may have occurred due to power sharing with other devices. Do not share the power supply with other devices. Connect the F3SG-SR/PG to a power supply that is dedicated to electro-sensitive protective devices for electro-sensitive protective equipment such as the F3SG-SR/PG, safety controller, etc.</p>
			1A	<p>Effect of noise may be excessive. If other devices using the same power supply generate noise, do not share the same power supply with other devices, and use a separate power supply exclusively for the safety components.</p> <p>The inductive noise tends to be induced especially if the power supply line of the machine guarded and the power supply line of the F3SG-SR/PG are arranged in parallel. Arrange the exclusive power supply near the F3SG-SR/PG or lay the power supply line of the F3SG-SR/PG away from the power supply line of the machine guarded.</p> <p>If the power supply for the F3SG-SR/PG is located near the power supply of the machine guarded and it shares the same grounding wire, it is subject to the influence of common mode noise. Separate the grounding point or use it as the exclusive ground.</p> <p> 5-4-4. <i>Functional Earth Connection</i></p>
Operating range selection setting error	X	X	EB	<p>The setting of the operating range selection may be incorrect.</p> <ul style="list-style-type: none"> • When the Intelligent Tap is connected, check if the Operating Range Selection of the DIP Switch is properly set. • When the Intelligent Tap is not connected, check if the Operating Range Select Input line is properly wired. <p> 2-20. <i>Operating Range Selection</i></p> <p> Chapter 3 <i>Setting with Intelligent Tap</i></p> <p> 5-4-3-12. <i>Reduced Wiring Connector System with Y-Joint Plug/Socket Connector</i></p>

Description	Checking by		Error code (hex)*1	Cause and measures
	Indicator	SD Manager 3/ SD Manager 3 Mobile APP		
External device monitoring error	- *3	X	52	Relay may be welded. Replace the relay.
				The relay and the RESET line may not be properly wired. Check the wiring with the relay.  2-11. External Device Monitoring (EDM)
				The relay response time may be exceeding the allowable delay time. Change the allowable delay time or replace the relay with one that has an appropriate response time.  2-11. External Device Monitoring (EDM)  4-3-2-1. Interlock/External Device Monitoring (EDM)/PSDI
Error other than those above	- *3	X	Error code other than those above	An error may have occurred in the internal circuit. Replace the F3SG-SR/PG.

*1. You can check the error codes by SD Manager 3 or SD Manager 3 Mobile APP.

*2. For more information on the error, refer to 8-1-4. *Troubleshooting for Intelligent Tap*.

*3. Other indicators than the ERR and MAINT indicators are not illuminated. For details of the error, refer to [Code] and [Error description] displayed in [Error Log] in the SD Manager 3.

8-1-3. Warning

8-1-3-1. Description

If an error is detected that prevents the F3SG-SR/PG to continue normal operation, the SEQ indicator or Area Beam Indicator (ABI) blinks to notify warning information according to the error. The F3SG-SR/PG continues normal operation. In the Auto Reset mode, the F3SG-SR/PG automatically recovers from the warning status when the cause of the error is solved. In the Manual Reset mode, the F3SG-SR/PG keeps the safety outputs in the OFF state. A reset signal is required to release the INTERLOCK state in this mode.

8-1-3-2. Troubleshooting

Identify an error according to the combination of the indicators when the error occurs. See the following troubleshooting tables to take measures.



<Indicator status at warning: Receiver and Emitter/Receiver *1>



Combination of indicators and error description

ERR indicator	MAINT indicator	Other indicators	Error description
		or	Teach-in error
		*2	Muting sequence error, Interlock sequence error or PSDI sequence error
		Area Beam Indicator Green	Malfuction due to ambient light or vibration
		Area Beam Indicator Orange →	Low incident light level (Factory default setting)

*1. In the case of warning, the emitter's indicator does not be turned ON or blink as warning error.

*2. There are several illumination patterns to identify a faulty sequence.

Description	Checking by		Warning code (hex)*1	Cause and measures
	Indicator	SD Manager 3/ SD Manager 3 Mobile APP		
Teach-in error	X	X	ED	Teach-in failed. Perform the Teach-in again. 3-7. Teach-in (Fix Blanking / Floating Blanking)
Muting sequence error	X	X	2C, 2D, 2F	Muting input may have been applied in the incorrect order. Check the pattern of illumination of the LED indicator to identify the cause. 8-1-3-3. Muting Sequence Error Indication
Interlock sequence error	X	-	-	When using the Pre-reset function, the reset signals for interlock may be input in the wrong order. Check the pattern of illumination of the LED indicator to identify the cause. 8-1-3-4. Interlock Sequence Error Indication

Description	Checking by		Warning code (hex)*1	Cause and measures
	Indicator	SD Manager 3/ SD Manager 3 Mobile APP		
PSDI sequence error	X	X	2A, 2B	PSDI input may have been applied in the correct order. Check if the pattern of illumination of the LED indicator to identify the cause.  8-1-3-5. PSDI Sequence Error Indication
Malfunction due to ambient light or vibration	-	X (SD Manager 3 Mobile APP is not applicable) *2	-	Malfunction may have occurred due to ambient light or instantaneous beam misalignment from vibration. Check the installation condition. Take necessary measures against mutual interference according to 5-1-4. Mutual Interference Prevention.  5-1-4. Mutual Interference Prevention
Low incident light level	X	X	12	The incident light level may be low due to dirty front window or misaligned beams caused by vibration. Clean the front window and check the alignment of the beams. Take necessary measures for this according to 5-3-5. Beam Alignment Procedure.  5-3-5. Beam Alignment Procedure
Low communications quality	- *3	X	F0	Retries of communications may have been generated due to noise. Check the noise level in the proximity of the communication lines.
				Retries of communications may have been generated due to short-circuit of the communication lines. Check the cables connected.

*1. You can check the error codes by SD Manager 3 or SD Manager 3 Mobile APP.



*2. You can check by instantaneous block detection logs in [Instantaneous Block Detection Information].





 2-29. Instantaneous Block Detection and 4-4-3-5. Instantaneous Block Detection Information.

*3. The indicators are not illuminated. For details of the warning, refer to [Code] and [Warning description] displayed in [Warning Log] in the SD Manager 3.

8-1-3-3. Muting Sequence Error Indication

The following table is applied only when the muting function is being enabled.







SEQ indicator	Cause and measures
 Blinking: Once	Power supply may have been turned ON with muting input A or B being ON. Check the condition of the muting sensors and the F3SG-SR.
	Muting input B may have been turned ON before muting input A was turned ON. Check the condition of the muting sensors.
	Muting input A and B may have been turned ON at the same time. <ul style="list-style-type: none"> • Check the arrangement of the muting sensors. • Check if the wiring of muting input A and B is short-circuited.
	Either muting input A or B may have been turned ON with the F3SG-SR/PG being blocked or INTERLOCK State. Check the condition of the F3SG-SR/PG.
 Blinking: Twice	Muting input B may have been turned ON within T1min (muting input time limit value (minimum)) (= 0.1 s*1) after muting input A was turned ON. <ul style="list-style-type: none"> • Check that if the muting sensors are installed too close each other. • Check that if the speed of the workpiece is too fast.
	It may have taken T1max (muting input time limit value (maximum)) (= 4 s*1) or longer for muting input B to be turned ON after muting input A was turned ON. <ul style="list-style-type: none"> • Check that if the muting sensors are installed too far each other. • Check that if the speed of the workpiece is too slow.
	The F3SG-SR/PG may have been blocked after muting input A was turned ON but before muting input B was turned ON. Check the condition of the F3SG-SR/PG.

SEQ indicator	Cause and measures
 Blinking: Four times	<p>The F3SG-SR/PG may have been blocked within 0.08 s after muting input A and B were normally turned ON.</p> <ul style="list-style-type: none"> • Check that if the muting sensor and the F3SG-SR/PG are installed too close each other. • Check that if the speed of the workpiece is too fast.
 Blinking: Five times	<p>Muting may have been released after the F3SG-SR/PG entered the MUTING state but before a workpiece blocked the F3SG-SR/PG.</p> <ul style="list-style-type: none"> • Check that the workpiece still remains. • Check that the speed of the workpiece is too slow.
 Blinking: Six times	<p>The F3SG-SR/PG entered the MUTING state, but muting may have then been released while a workpiece passes through the F3SG-SR/PG.</p> <ul style="list-style-type: none"> • Check that the workpiece still remains. • Check that if the speed of the workpiece is too slow. • Check that the muting sensors have been installed upstream and downstream of the F3SG-SR/PG with the size of workpieces taken into account. (Using four muting sensors)
 Blinking: Seven times	<p>Muting may have been released with muting input A and B remained ON after a workpiece passed through the F3SG-SR/PG.</p> <ul style="list-style-type: none"> • Check that the workpiece still remains. • Check that the speed of the workpiece is too slow.
 Blinking: Seven times	<p>The next muting sequence may have started after muting was released but before the initial muting condition was established.</p> <ul style="list-style-type: none"> • Check that if a next workpiece has not entered before the current workpiece passes through the F3SG-SR/PG. • Check that if the interval between workpieces are too narrow.

*1 Factory default setting





8-1-3-4. Interlock Sequence Error Indication

The following table is applied only when the pre-reset function is being enabled.

SEQ indicator	Cause and measures
 Blinking: Once	<p>The reset or pre-reset switch may have been pressed before the F3SG-SR/PG receives light.</p> <p>Check the wiring of the reset and pre-reset signals.</p>
 Blinking: Twice	<p>The F3SG-SR/PG may have been blocked or the pre-reset switch may have been pressed before the pre-reset switch is pressed.</p> <p>Check the status of the F3SG-SR/PG and the wiring of the pre-reset signal.</p>
 Blinking: Three times	<p>After the pre-reset switch was pressed, the pre-reset or reset switch may have been pressed before the F3SG-SR/PG is blocked.</p> <p>Check the installation environment of the F3SG-SR/PG.</p>
 Blinking: Three times	<p>After the pre-reset switch was pressed and the F3SG-SR/PG was blocked, the pre-reset switch may have been pressed before the reset switch is pressed.</p> <p>Check the wiring of the pre-reset signal.</p>
 Blinking: Three times	<p>After the pre-reset switch was pressed, a time period from the block of the F3SG-SR/PG to the press of the reset switch may have exceeded the allowable time.</p> <p>Check the installation environment of the F3SG-SR/PG as well as pre-reset and reset switches.</p>
 Blinking: Three times	<p>The number of blocks of the F3SG-SR/PG may have exceeded the allowable value after the pre-reset switch was pressed and before the reset switch is pressed.</p> <p>Check the installation environment of the F3SG-SR/PG.</p>

8-1-3-5. PSDI Sequence Error Indication

The following table is applied only when the PSDI function is being enabled.

SEQ indicator	Error condition	Cause and measures
 Blinking: Once	●	Power supply may have been turned ON with PSDI input being OFF. Check the condition of the light curtains and PSDI input wiring.
	●	Power supply may have been turned ON with the light curtain blocked. Check the condition of the light curtains and PSDI input wiring.
	●	Power supply may have been turned ON with RESET input being OFF. Check the condition of the light curtains and RESET input wiring.
	●	PSDI input may have been turned OFF before RESET input was turned OFF. Check the PSDI input wiring.
	●	The light curtain may have been blocked before RESET input was turned ON. Check the condition of the light curtains and RESET input wiring.
	●	The PSDI input may have turned OFF while the RESET input is OFF. Check the condition of the light curtains and PSDI input wiring.
	●	The light curtain may have been blocked before RESET input was turned ON. Check the condition of the light curtains and RESET input wiring.
 Blinking: Twice	●	After RESET input, the light curtain may not be blocked longer than T2 (minimum break time) and the PSDI input may have turned OFF. Check the condition of the light curtains and RESET input wiring.
	●	The PSDI input may have turned OFF with the light curtain blocked. Check the condition of the light curtains and PSDI input wiring.
	○	PSDI input may have turned OFF before the light curtain blocked twice. Check the condition of the light curtains and PSDI input wiring.
 Blinking: Three times	●	The light curtain was blocked before the PSDI input turned OFF. Check the condition of the light curtains and PSDI input wiring.
	●	The light curtain was blocked while the PSDI input turned OFF. Check the condition of the light curtains and PSDI input wiring.
 Blinking: Four times	●	PSDI input may have turned OFF during the period from when the PSDI state is cancelled until the light curtain blocked. Check the condition of the light curtains and PSDI input wiring.
	●	The PSDI input may have turned OFF with the light curtain blocked. Check the condition of the light curtains and PSDI input wiring.
	○	T4 (waiting time for break end of one time) after the PSDI state is released until the break is released might have exceeded 30 s. Check the condition of the light curtains and PSDI input wiring.
	○	T6 (muting end waiting time) after the PSDI state is released until the break is released might have exceeded 30 s. Check the condition of the light curtains and PSDI input wiring.
	○	The PSDI input may have turned OFF again before the light curtain blocked. Check the condition of the light curtains and PSDI input wiring.
	○	After PSDI is input, if the light curtain is blocked twice, the time elapsing until the second blocking ends must be within T6 (30 s). So, T6 (muting end waiting time) might have elapsed. Check the condition of the light curtains and PSDI input wiring.
	○	PSDI input may have turned OFF before the light curtain blocked again. Check the light curtain status and PSDI input wiring.

Notations

- ...Single Break
- ...Double Break
- ...Common

8-1-4. Troubleshooting for Intelligent Tap

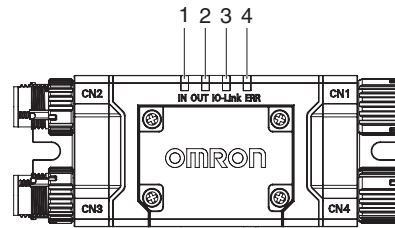

1	IN
2	OUT
3	IO-Link
4	ERR

If the Intelligent Tap detects any failure, it transitions to the LOCKOUT state. Under the LOCKOUT state, the ERR indicator is turned ON. Identify an error according to the combination of the indicators when the error occurs. See the following troubleshooting tables to take measures.







Combination of indicators and error description

ERR (Red)	IN (Yellow)	OUT (Green/Red)	IO-Link (Green)	Error description
	—	—	—	Communication error DIP Switch circuit error at startup
			—	Communication error in Backup
		Green	—	Communication error in Restoration
		Red	—	Communication error between the F3SG-SR/PG and the Intelligent Tap
		Green	—	Restoration failed
		Red	—	LOCKOUT state of the F3SG-SR/PG
	—	—		IO-Link circuit error
	—	—	—	Power supply voltage error, or other errors

- CHECK!**
- The signals output to IO-Link or IN and OUT indicators show the statuses of the F3SG-SR/PG or Intelligent Tap except their LOCKOUT state.
 - The muting inputs A and B are kept in the OFF state when the LOCKOUT state occurs due to the power supply voltage error.

Description	Checking by		Error code (hex)*	Cause and measures
	Indicator	SD Manager 3		
Communication error	X	X	1D	The communication lines or other lines may be short-circuited or broken. Check the cables for cascading or extension cables. If the wiring is extended with cables other than specified, the cables used for extension may not have performance equivalent or greater than the specified cables. Use cables with the same performance or more than the specified cables.

Description	Checking by		Error code (hex)*	Cause and measures
	Indicator	SD Manager 3		
Communication error in Backup	X	X	1E	<p>The communication lines or other lines may be short-circuited or broken.</p> <p>Check the cables for cascading or extension cables. If the wiring is extended with cables other than specified, the cables used for extension may not have performance equivalent or greater than the specified cables. Use cables with the same performance or more than the specified cables.</p> <p>Effect of noise may be excessive.</p> <p>If other devices using the same power supply generate noise, do not share the same power supply with other devices, and use a separate power supply exclusively for the safety components.</p> <p>The inductive noise tends to be induced especially if the power supply line of the machine guarded and the power supply line of the Intelligent Tap are arranged in parallel. Arrange the exclusive power supply near the Intelligent Tap or lay the power supply line of the Intelligent Tap away from the power supply line of the machine guarded.</p> <p>If the power supply for the Intelligent Tap is located near the power supply of the machine guarded and it shares the same grounding wire, it is subject to the influence of common mode noise. Separate the grounding point or use it as the exclusive ground.</p> <p> 5-4-4. Functional Earth Connection</p> <p>The internal circuit of the Intelligent Tap may be defective. Replace the Intelligent Tap.</p>
Communication error in Restoration	X	X	1F	<p>The communication lines or other lines may be short-circuited or broken.</p> <p>Check the cables for cascading or extension cables. If the wiring is extended with cables other than specified, the cables used for extension may not have performance equivalent or greater than the specified cables. Use cables with the same performance or more than the specified cables.</p> <p>Effect of noise may be excessive.</p> <p>If other devices using the same power supply generate noise, do not share the same power supply with other devices, and use a separate power supply exclusively for the safety components.</p> <p>The inductive noise tends to be induced especially if the power supply line of the machine guarded and the power supply line of the Intelligent Tap are arranged in parallel. Arrange the exclusive power supply near the Intelligent Tap or lay the power supply line of the Intelligent Tap away from the power supply line of the machine guarded.</p> <p>If the power supply for the Intelligent Tap is located near the power supply of the machine guarded and it shares the same grounding wire, it is subject to the influence of common mode noise. Separate the grounding point or use it as the exclusive ground.</p> <p> 5-4-4. Functional Earth Connection</p> <p>The internal circuit of the Intelligent Tap may be defective. Replace the Intelligent Tap.</p>
Communication error between the F3SG-SR/PG and the Intelligent Tap	X	-	-	<p>The F3SG-SR/PG may be disconnected from the Intelligent Tap, the communication line of the F3SG-SR/PG may be broken, or the internal circuit of the Intelligent Tap may be defective. Check the connection and cable wiring between the Intelligent Tap and the F3SG-SR/PG. In the case of defective internal circuit, replace the Intelligent Tap.</p>

Description	Checking by		Error code (hex)*	Cause and measures
	Indicator	SD Manager 3		
F3SG-SR/PG LOCKOUT state	X	-	-	The F3SG-SR/PG is in the LOCKOUT state. For details of the error of the F3SG-SR/PG, check the indicator status or error code of the F3SG-SR/PG.  8-1-2. LOCKOUT State
Restoration failed	X	-	-	The sensor configuration (sensor model, connection configuration, etc.) stored in the Intelligent Tap by the Backup process does not match the sensor configuration of the connected F3SG-SR/PG. Connect the F3SG-SR/PG with the same sensor configuration as the backed-up sensor configuration, or perform the Backup process of the connected F3SG-SR / PG. Error codes are not recorded. Refer to 3-6. Backup/Restoration for more information on the Backup and Restoration procedures.  3-6. Backup/Restoration
Power supply voltage error, or other errors	X	X	A3	The muting inputs A and B are kept in the OFF state when the LOCKOUT state occurs due to the power supply voltage error. The power supply voltage may have dropped temporarily when the F3SG-SR/PG is in operation. Check for temporary power supply voltage drop (by about 12 VDC) by the influence of the inductive load, etc. If the exclusive power supply is not used, check the power consumption of other connected devices for enough capacity. Power supply voltage may be outside the rated range. Connect the F3SG-SR/PG to a 24 VDC±20% power supply voltage. Voltage fluctuation may have occurred due to insufficient power supply capacity. Replace the power supply with one that has a larger capacity. Instantaneous break or instantaneous stop may have occurred due to power sharing with other devices. Do not share the power supply with other devices. Connect the F3SG-SR/PG to a power supply that is dedicated to electro-sensitive protective devices for electro-sensitive protective equipment such as the F3SG-SR/PG, safety controller, etc.
DIP Switch circuit error at startup	X	X	BC	The internal circuit may be defective. Replace the Intelligent Tap.
IO-Link circuit error	X	X	BD	The internal circuit may be defective. Replace the Intelligent Tap.
Internal error	X	X	Others	The internal circuit may be defective. Replace the Intelligent Tap.

* You can check the error codes by SD Manager 3 or SD Manager 3 Mobile APP.

8-1-5. Troubleshooting for Bluetooth® Communication Unit

See the following troubleshooting table to take measures if any of the phenomena in the table occurs when in the connection with the Bluetooth® Communication Unit.

Status	Measures
Communications cannot be established	Check if Bluetooth® Communication Unit is properly mounted.
	Check if Bluetooth® function is enabled on the device you use for SD Manager 3.
	Check if Bluetooth® Communication Unit is not being paired with another device.
	Check if Bluetooth® Communication Unit and the device you use for SD Manager 3 are properly paired (or the connection is verified). *
	Check if Bluetooth® function of the device you use for SD Manager 3 supports SPP (Serial Port Profile).
	Check if a COM port is properly configured.
	Check the noise level in the environment.
	Check if there is any device that uses 2.4 GHz band.
	Check if there is any obstruction between Bluetooth® Communication Unit and the device you use for SD Manager 3. The maximum permissible line-of-sight distance is approximately 10 m.
	The F3SG-SR/PG is under the SETTING state. Turn OFF and ON the power of the F3SG-SR/PG.
Files cannot be read from the outside while the sensor is connected	The sensor model in the saved file does not match the sensor model in the file that you are about to read in. Check the sensor model.
	If a file is saved by SD Manager 3 of a newer version than your SD Manager 3, the file is not usable on your SD Manager 3. Check the SD Manager 3 version.
F3SG-SR/PG does not go back to normal state after terminating SD Manager 3	Restart F3SG-SR/PG. If SD Manager 3 does not operate normally even after restarted, use the setup recovery function to restore to the factory default settings again.

* The procedure depends on the device you use for SD Manager 3. Refer to instruction manuals of the device.

8-2. Optional Accessories (Sold Separately)

Side-Mount Bracket (Intermediate Bracket)

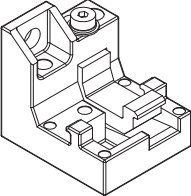
Appearance	Model	Application	Remarks
	F39-LSGF	Bracket to mount F3SG-SR/PG. Side mounting and backside mounting are available. Beam cannot be adjusted after F3SG-SR/PG is mounted.	A set of 2 brackets.

Adjustable Side-Mount Bracket (Intermediate Bracket)

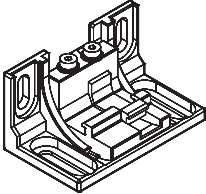
Appearance	Model	Application	Remarks
	F39-LSGA	Bracket to mount the F3SG-SR/PG. Beam alignment after mounting possible. The angle adjustment range is $\pm 15^\circ$. Side mounting and backside mounting possible.	A set of 2 brackets.

Adjustable Top/Bottom Bracket (F3SJ, F3SN Adapter)

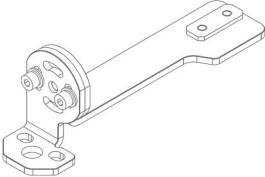
Appearance	Model	Application	Remarks
	F39-LSGTB-SJ	Bracket to mount the F3SG-SR/PG. Use this bracket at the top and bottom positions of the F3SG-SR/PG. Beam alignment after mounting possible. The angle adjustment range is $\pm 22.5^\circ$. Side mounting and backside mounting possible. Use this bracket when replacing an existing F3SJ or F3SN Safety Light Curtain with F3SG-SR.	A set of 2 brackets.

Adjustable Top/Bottom Bracket (F3SG-RA/RE Adapter)

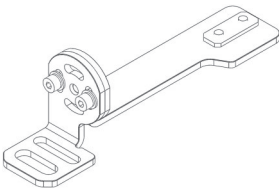
Appearance	Model	Application	Remarks
	F39-LSGTB-RE	Bracket to mount the F3SG-SR/PG. Use this bracket at the top and bottom positions of the F3SG-SR/PG. Beam alignment after mounting possible. The angle adjustment range is $\pm 22.5^\circ$. Side mounting and backside mounting possible. Use this bracket when replacing an existing F3SG-RA/RE Safety Light Curtain with F3SG-SR.	A set of 2 brackets.

Adjustable Top/Bottom Bracket (MS4800, F3SR Adapter)

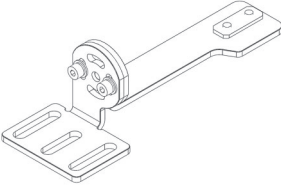
Appearance	Model	Application	Remarks
	F39-LSGTB-MS	Bracket to mount the F3SG-SR/PG. Use this bracket at the top and bottom positions of the F3SG-SR/PG. Beam alignment after mounting possible. The angle adjustment range is $\pm 22.5^\circ$. Side mounting and backside mounting possible. Use this bracket when replacing an existing MS4800 or F3SR-B Safety Light Curtain with F3SG-SR.	A set of 2 brackets.

IP69K Model Mounting Bracket

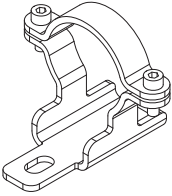
Appearance	Model	Application	Remarks
	F39-LSGTB-K	Bracket to mount F3SG-SR-K. A 360-degree mounting including side mounting and backside mounting is available.	A set of 2 brackets.

Root-Straight Cable for Emitter

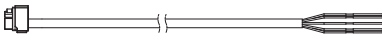
Appearance	Model	Cable length	Remarks
	F39-JG3C-L	3 m	To sensor: dedicated connector, To external: open-ended type 5 wires
	F39-JG7C-L	7 m	
	F39-JG10C-L	10 m	

Root-Straight Cable for Receiver or Emitter/Receiver

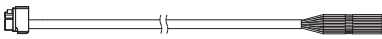
Appearance	Model	Cable length	Remarks
	F39-JG3C-D	3 m	To sensor: dedicated connector, To external: open-ended type 8 wires
	F39-JG7C-D	7 m	
	F39-JG10C-D	10 m	

Root-Plug Cable for Extended for Emitter

Appearance	Model	Cable length	Remarks
	F39-JGR3K-L	0.3 m	To sensor: dedicated connector, To external: M12 connector type (8-pin)

Root-Plug Cable for Extended for Receiver or Emitter/Receiver

Appearance	Model	Cable length	Remarks
	F39-JGR3K-D	0.3 m	To sensor: dedicated connector, To external: M12 connector type (8-pin)

Extended Socket-Straight Cable for Emitter

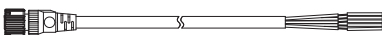
Appearance	Model	Cable length	Remarks
	F39-JG3A-L	3 m	M12 connector (5-pin), 5 wires
	F39-JG7A-L	7 m	
	F39-JG10A-L	10 m	
	F39-JG15A-L	15 m	
	F39-JG20A-L	20 m	

Extended Socket-Straight Cable for Receiver or Emitter/Receiver

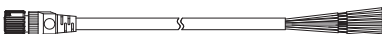
Appearance	Model	Cable length	Remarks
	F39-JG3A-D	3 m	M12 connector (8-pin), 8 wires
	F39-JG7A-D	7 m	
	F39-JG10A-D	10 m	
	F39-JG15A-D	15 m	
	F39-JG20A-D	20 m	

Extended Plug-Socket Cable for Emitter

Appearance	Model	Cable length	Remarks
	F39-JGR5B-L	0.5 m	M12 connector (5-pin) on both ends
	F39-JG1B-L	1 m	
	F39-JG3B-L	3 m	
	F39-JG5B-L	5 m	
	F39-JG7B-L	7 m	
	F39-JG10B-L	10 m	
	F39-JG15B-L	15 m	
	F39-JG20B-L	20 m	

Extended Plug-Socket Cable for Receiver or Emitter/Receiver

Appearance	Model	Cable length	Remarks
	F39-JGR5B-D	0.5 m	M12 connector (8-pin) on both ends
	F39-JG1B-D	1 m	
	F39-JG3B-D	3 m	
	F39-JG5B-D	5 m	
	F39-JG7B-D	7 m	
	F39-JG10B-D	10 m	
	F39-JG15B-D	15 m	
	F39-JG20B-D	20 m	

Cascading Cable for Extended (Two cables per set, one for emitter and one for receiver)

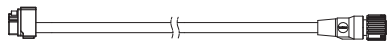
Appearance	Model	Cable length	Remarks
	F39-JGR3W	0.3 m	<p>For emitter To sensor: dedicated connector, To cascading sensor: M12 connector type (5 pin)</p> <p>For receiver To sensor: dedicated connector, To cascading sensor: M12 connector type (8 pin)</p>

Side-by-side Cascading Cable (Two cables per set, one for emitter and one for receiver)

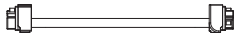
Appearance	Model	Cable length	Remarks
	F39-JGR12L	12 cm	<p>For emitter To sensor: dedicated connector 1, To cascading sensor: dedicated connector 2</p> <p>For receiver To sensor: dedicated connector 1, To cascading sensor: dedicated connector 2</p>

F3SJ-A/B Conversion Cable

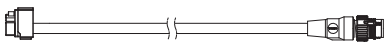
Appearance	Model	Cable length	Remarks
	F39-JGR3K-SJ-L	0.3 m	<p>For emitter (F39-JGR3K-SJ-L) To sensor: dedicated connector 1, To wires for F3SJ-A/B: M12 connector type (8 pin)</p> <p>For receiver (F39-JGR3K-SJ-D) To sensor: dedicated connector 1, To wires for F3SJ-A/B: M12 connector type (8 pin) Used to convert the wiring for F3SJ-A/B, F3SR-B or F3SN Safety Light Curtain to that for the F3SG-SR/PG.</p>
	F39-JGR3K-SJ-D		

F3SG-RE Conversion Cable

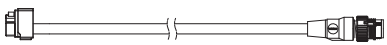
Appearance	Model	Cable length	Remarks
	F39-JGR3K-RE-L	0.3 m	<p>For emitter (F39-JGR3K-RE-L) To sensor: dedicated connector 1, To wires for F3SG-RE: M12 connector type (4 pin)</p> <p>For receiver (F39-JGR3K-RE-D) To sensor: dedicated connector 1, To wires for F3SG-RE: M12 connector type (4 pin) Used to convert the wiring for F3SG-RE Safety Light Curtain to that for the F3SG-SR/PG.</p>
	F39-JGR3K-RE-D		

MS48 Conversion Cable

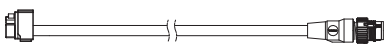
Appearance	Model	Cable length	Remarks
	F39-JGR3K-MS-L	0.3 m	<p>For emitter (F39-JGR3K-MS-L) To sensor: dedicated connector 1, To wires for MS4800: M12 connector type (5 pin)</p> <p>For receiver (F39-JGR3K-MS-D) To sensor: dedicated connector 1, To wires for MS4800: M12 connector type (8 pin) Used to convert the wiring for MS4800 Safety Light Curtain to that for the F3SG-SR/PG.</p>
	F39-JGR3K-MS-D		

F3SJ-A/B-TS/T, F3SG-RA-TS Conversion Cable

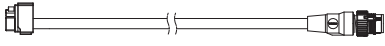
Appearance	Model	Cable length	Remarks
	F39-JGR3K-SW-L	0.3 m	For emitter (F39-JGR3K-SW-L) To sensor: dedicated connector 1, To wires for F3SJ-A/B-TS/T: M12 connector type (8 pin) For receiver (F39-JGR3K-SJ-D) To sensor: dedicated connector 1, To wires for F3SJ-A/B-TS/T: M12 connector type (8 pin) Used to convert the wiring for F3SJ-A/B-TS/T or F3SG-RA-TS Safety Light Curtain to that for the F3SG-SR/PG.
	F39-JGR3K-SJ-D		

Intelligent Tap

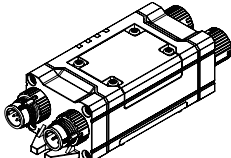
Appearance	Model	Application	Remarks
	F39-SGIT-IL3	Used to configure the F3SG-SR/PG and connect external devices via IO-Link.	Material: PBT resin (Body parts)

Intelligent Tap Bracket

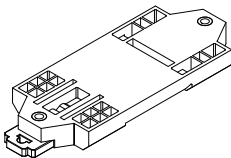
Appearance	Model	Application	Remarks
	F39-LITF1	Bracket to mount the Intelligent Tap on a DIN track.	Material: PBT resin (Body parts)

Root-Straight Cable for IO-Link

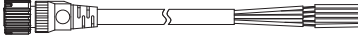
Appearance	Model	Application	Remarks
	XS5F-D521-DJ0-IL	2 m	M12 connector (5-pin), 5 wires. Used to connect an Intelligent Tap to an IO-Link Master unit of Push-in Terminal Block type.

Bluetooth® Communication Unit

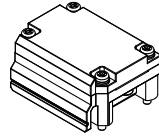
Appearance	Model	Application	Remarks
	F39-SGBT	Mounted to the Intelligent Tap to connect with the SD Manager 3 via Bluetooth.	Material: PBT resin (Body parts)

Y-Joint Plug/Socket Connector

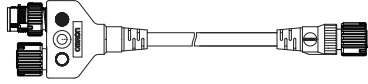
Appearance	Model	Application	Remarks
	F39-GCNY2	0.5 m	M12 connectors Used for reduced wiring.

Reset Switch Connector

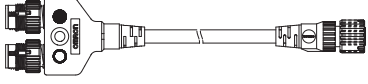
Appearance	Model	Application	Remarks
	F39-GCNY3	3 m	M12 connectors. Used for reduced wiring when connecting to a reset switch.

Connector Connected to Cable, Socket on One Cable End

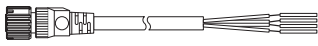
Appearance	Model	Application	Remarks
	XS5F-D421-C80-F	1 m	M12 connector (4-pin), 4 wires. Used to connect a reset switch connector to a reset switch.
	XS5F-D421-D80-F	2 m	
	XS5F-D421-E80-F	3 m	
	XS5F-D421-G80-F	5 m	
	XS5F-D421-J80-F	10 m	
	XS5F-D421-L80-F	20 m	

Muting Sensor

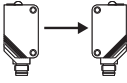
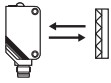
Appearance	Model	Sensing method / output type	Sensing distance
	E3Z-T66A	Through-beam/NPN output	10 m
	E3Z-T86A	Through-beam/PNP output	10 m
	E3Z-R66	Retroreflective/NPN output	2 m
	E3Z-R86	Retroreflective/PNP output	2 m
	E39-R1S	Retroreflective/Reflectors	2 m

Muting Sensor Arm Mounter (Two mounters per set, for emitter and receiver)

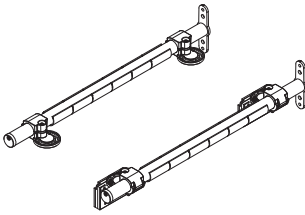
Appearance	Model	Length	Remarks
	F39-FMA150T	150mm	A through-beam muting sensor can be mounted easily.
	F39-FMA400T	400mm	
	F39-FMA150R	150mm	A retroreflective muting sensor can be mounted easily.
	F39-FMA400R	400mm	

* 2 sets are required when using Standard Muting Mode, and 1 set is required when using Exit-Only Muting Mode.

Muting Sensor Arm Mounter Bracket for SLC

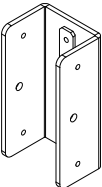
Appearance	Model	Remarks
	F39-LMAF1	For emitter and receiver, one piece each or one set each Common use for F3SG-SR/PG * The muting sensor stand bracket (F39-LMAF1) cannot be used for the F3SG-SR/PG with a product length smaller than 280 mm.

Muting Sensor Connector Box

Appearance	Model	Application	Remarks
	F39-GCN5	0.5 m	Main unit: M12 connector (5-pin) x 7, M12 connector (8-pin) x 1 Cable: M12 connector (8-pin) x 1 Man-hours to wire the muting sensor can be reduced.
	XS3W-M42C-4C2-A	0.2 m	M8 connector/M12 Plug-Socket Cable (4-pin) Connection cable between the muting sensor (E3Z) and muting sensor connector box (F39-GCN5)
	XS3W-M421-401-R	1 m	M8 connector/M8 plug socket cable (4-pin) straight type If you need more than 0.5m between the muting sensor (E3Z) and muting sensor connector box (F39GCN), use XS3W-M42C-4C2-A to extend the cable.
	XS3W-M421-402-R	2 m	
	XS3W-M421-405-R	5 m	
	XS3W-M421-410-R	10 m	
	XS3W-M424-402-R	2 m	M8 connector (L type)/M8 plug socket (straight type) cable (4-pin) If the connector block gap of the muting sensor (E3Z) is from 40 to 80 mm, use XS3W-M42C-4C2-A in combination.
	XS3W-M424-405-R	5 m	

Laser Alignment Kit

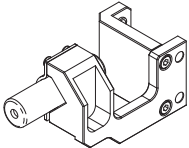
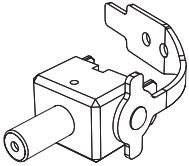
Appearance	Model	Application	Remarks
	F39-PTS	You can attach this to F3SG-SR/PG. The laser light assists coarse beam alignment.	<ul style="list-style-type: none"> Mountable from the front. This can be easily mounted and removed to/from the main unit, even as a set with the F39-ST. Red semiconductor laser (wavelength 650 nm, 1 mW max., JIS Class 2, IEC Class 2, FDA Class II)
	F39-PTG		<ul style="list-style-type: none"> This can be mounted even from above the Spatter Protection Cover. Red semiconductor laser (wavelength 650 nm, 1 mW max., JIS Class 2, IEC Class 2, FDA Class II)

Test Rod

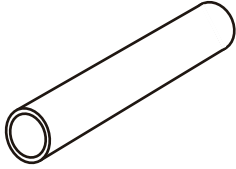
Appearance	Model	Diameter
	F39-TRD14 F39-TRD25 F39-TRD30	14 mm dia. 25 mm dia. 30 mm dia.



To check operation before use, purchase and use the test rod.

CHECK!

Spatter Protection Cover (Two pieces per set, one for emitter and one for receiver)

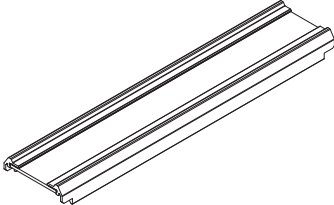
Appearance	Model	Remarks
	F39-HSG□□□□	Two pieces per set, common for emitter/receiver. For the F3SG-SR of the protective height of 2,000 mm or longer, use two Spatter Protection Covers of different lengths. Please note the following: • The operating range of the F3SG-SR attached with the Spatter Protection Cover is 10% shorter than the rating. Material: PC resin (Transparent cover), ABS resin (Side wall)

Lamp

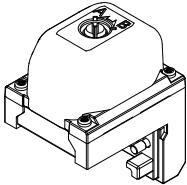
Appearance	Model	Remarks
	F39-SGLP	Attached to the emitter, receiver, or emitter/receiver and shows the operating state of F3SG-SR/PG by the indicator state.

Floor Mounting Column

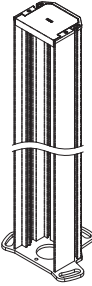
Appearance	Model	Column Height	Remarks
	F39-ST0990	990mm	Sensors with a product length of 880 mm or less can be mounted.
	F39-ST1310	1,310mm	Sensors with a product length of 1,220 mm or less can be mounted.
	F39-ST1630	1,630mm	Sensors with a product length of 1,520 mm or less can be mounted.
	F39-ST1950	1,950mm	Sensors with a product length of 1,840 mm or less can be mounted.
	F39-ST2270	2,270mm	Sensors with a product length of 2,080 mm or less can be mounted.

* When using the floor-standing stand, the intermediate fitting of F3SG-SR/PG is not required.

Mirror Column (for Safety Light Curtain F3SG-SR and Safety Multi-Light Beam F3SG-PGA-A/L)

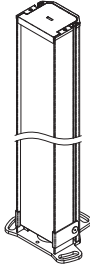
Appearance	Model	Column Height	Remarks
	F39-SML0990	990mm	Sensors with a product length of 880 mm or less can be mounted.
	F39-SML1310	1,310mm	Sensors with a product length of 1,200 mm or less can be mounted.
	F39-SML1630	1,630mm	Sensors with a product length of 1,520 mm or less can be mounted.
	F39-SML1950	1,950mm	Sensors with a product length of 1,840 mm or less can be mounted.

Mirror Column (for Safety Multi-Light Beam F3SG-PGA-A/L)

Appearance	Model	Column Height	Remarks
	F39-PML0990-2	990mm	Usable for F3SG-4PGA0670-2A/-2L.
	F39-PML1310-3	1,310mm	Usable for F3SG-4PGA0970-3A/-3L.
	F39-PML1310-4		Usable for F3SG-4PGA1070-4A/-4L.
	F39-PML1630-4	1,630mm	Usable for F3SG-4PGA1370-4A/-4L.

Mount-Column Adjustable Base

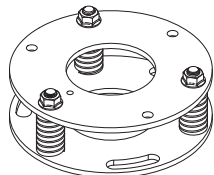
Appearance	Model	Remarks
	F39-STB	Used as mounted on the floor mounting column or the mirror column. Column's angle and height can be adjusted.

Safety Relay Units

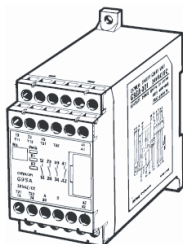
Appearance	Model	Output	Remarks
	G9SA-301 G9SA-321-T075 G9SA-321-T15 G9SA-321-T30	Safety output (relay): NO contact x 3 Auxiliary output (relay): NC contact x 1	<ul style="list-style-type: none"> An F39-JG□C Root-Straight Cable or the combination of an F39-JGR3K Root-Plug Cable for Extended and an F39-JG□A Single-Ended Cable is required. An F3SG-SR/PG in PNP system can be connected.
	G9SA-501	Safety output (relay): NO contact x 5 Auxiliary output (relay): NC contact x 1	

Safety Relay Units

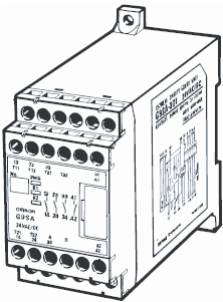
Appearance	Model	Output	Remarks
	G9SA-301-P	Safety output (relay): NO contact x 3 Auxiliary output (relay): NC contact x 1	<ul style="list-style-type: none"> An F39-JG□C Root-Straight Cable or the combination of an F39-JGR3K Root-Plug Cable for Extended and an F39-J□GA Single-Ended Cable is required. An F3SG-SR/PG in NPN system can be connected.

Safety Relay Units

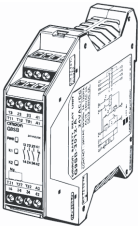
Appearance	Model	Output	Remarks
	G9SB-301-B	Safety output (relay): NO contact x 3 Auxiliary output (relay): NC contact x 1 Auto reset	<ul style="list-style-type: none"> An F39-JG□C Root-Straight Cable or the combination of an F39-JGR3K Root-Plug Cable for Extended and an F39-JG□A Single-Ended Cable is required. An F3SG-SR/PG in PNP system can be connected.
	G9SB-301-D	Safety output (relay): NO contact x 3 Auxiliary output (relay): NC contact x 1 Manual reset	
	G9SB-200-B	Safety output (relay): NO contact x 2 Auto reset	
	G9SB-200-D	Safety output (relay): NO contact x 2 Manual reset	

Flexible Safety Units

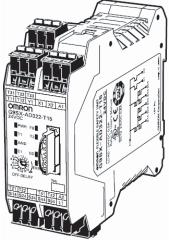
Appearance	Model	Output	Remarks
	G9SX-AD322-T15	Safety output (solid-state): source output (PNP) x 3 (instantaneous), source output (PNP) x 2 (OFF-delayed) Auxiliary output (solid-state): source output (PNP) x 2	<ul style="list-style-type: none"> An F39-JG□C Root-Straight Cable or the combination of an F39-JGR3K Root-Plug Cable for Extended and an F39-JG□A Single-Ended Cable is required. An F3SG-SR/PG in PNP system can be connected. 16 patterns of OFF-delayed output for up to 15 s can be set. The OFF-delayed output can be used as instantaneous output by setting it to 0 s. Can be configured for partial control and total control. Can be extended to connect a relay unit.

Safety Controllers

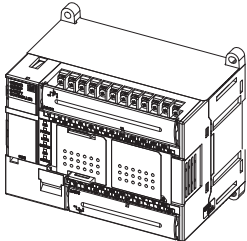
Appearance	Model	Output	Remarks
	G9SP-N10S	Safety output (solid-state): source output (PNP) x 4 Test output (solid-state): source output (PNP) x 4 Standard output (solid-state): source output (PNP) x 4	<ul style="list-style-type: none"> An F39-JG□C Root-Straight Cable or the combination of an F39-JGR3K Root-Plug Cable for Extended and an F39-JG□A Single-Ended Cable is required. An F3SG-SR/PG in PNP system can be connected.
	G9SP-N10D	Safety output (solid-state): source output (PNP) x 16 Test output (solid-state): source output (PNP) x 6	
	G9SP-N20S	Safety output (solid-state): source output (PNP) x 8 Test output (solid-state): source output (PNP) x 6	

Safety Input Units

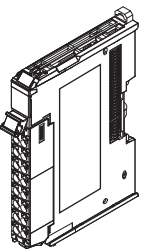
Appearance	Model	Application	Specifications
	NX-SIH400	Safety input (solid-state): sink input (PNP) x 4 Test output (solid-state): source output (PNP) x 2	<ul style="list-style-type: none"> An F39-JG□C Root-Straight Cable or the combination of an F39-JGR3K Root-Plug Cable for Extended and an F39-JG□A Single-Ended Cable is required. An F3SG-SR/PG in PNP system can be connected.
	NX-SID800	Safety input (solid-state): sink input (PNP) x 8 Test output (solid-state): source output (PNP) x 2	

Safety Relay Units

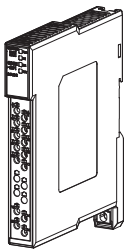
Appearance	Model	Application	Specifications
	G9SE-201	Safety output (relay): NO contact x 2 (instantaneous) Auxiliary output (solid-state): source output (PNP) x 1	<ul style="list-style-type: none"> An F39-JG□C Root-Straight Cable or the combination of an F39-JGR3K Root-Plug Cable for Extended and an F39-JG□A Single-Ended Cable is required. An F3SG-SR/PG in PNP system can be connected. For G9SE-221-T□, 16 patterns of OFF-delayed output for up to 5 or 30 s can be set.
	G9SE-401	Safety output (relay): NO contact x 4 (instantaneous) Auxiliary output (solid-state): source output (PNP) x 1	
	G9SE-221-T□	Safety output (relay): NO contact x 2 (instantaneous), NO contact x 2 (OFF-delayed) Auxiliary output (solid-state): source output (PNP) x 1	

Safety I/O Terminals

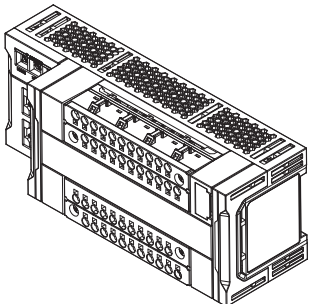
Appearance	Model	Output	Remarks
	GI-SMD1624	Safety output (solid-state): source output (PNP) x 4 Test output (solid-state): source output (PNP) x 12	<ul style="list-style-type: none"> An F39-JG□C Root-Straight Cable or the combination of an F39-JGR3K Root-Plug Cable for Extended or an F39-JG□A Single-Ended Cable is required. An F3SG-SR/PG in PNP system can be connected.
	GI-SID1224	No safety output Test output (solid-state): source output (PNP) x 12	

IO-Link Master Unit

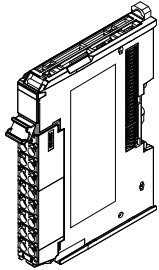
Appearance	Model	Number of IO-Link ports	Remarks
	NX-ILM400	4	<ul style="list-style-type: none"> I/O connection terminals: screwless clamping terminal block An F39-JG□C Root-Straight Cable or the combination of an F39-JGR3K Root-Plug Cable for Extended and an XS5F-D521-DJ0-IL Single-Ended Cable is required. An F39-SGIT-IL3 Intelligent Tap is required to connect to IO-Link.

IO-Link Master Unit

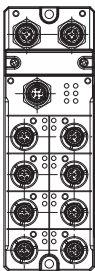
Appearance	Model	Number of IO-Link ports	Remarks
	GX-ILM08C	8	<ul style="list-style-type: none"> I/O connection terminals: M12 connector (A-cording, female) An F39-JGR3K Root-Plug Cable for Extended and an F39-JG□B-L Double-Ended Cable are required. An F39-SGIT-IL3 Intelligent Tap is required to connect to IO-Link.

8-3. Glossary

	Term	Description
A	Accumulated load switching frequency	Total number of operations of a load to be connected to the F3SG-SR, from when the F3SG-SR is first energized until the present time.
	Allowable Beams	Dynamic Muting: Area(s) (or beam(s)) to be added in a Dynamic Muting zone, in order to prevent an accidental interruption of the F3SG-SR due to vibration.
		Fixed/Floating Blanking: Beam(s) in a Blanking zone, that are not monitored by the Blanking Monitoring function.
	Allowable delay time	The allowable amount of time difference from when the state of the Safety outputs changes until the state of an external relay changes. The F3SG-SR enters the LOCKOUT state if this time is exceeded.
	Auto reset mode	Mode that disables Start Interlock and Restart Interlock. The Safety outputs are turned ON when no object is detected in the detection zone.
	Auxiliary output	Function to give output signal according to the settings. This must not be used for safety applications.
B	Blanking zone	Area in the detection zone of the F3SG-SR, where the Fixed Blanking or the Floating Blanking is enabled.
C	Configuration Tool	Setting tool that allows the user to make settings to the F3SG-SR with a PC.
D	Designated beam output	Function to signal the state of user-designated beam(s) to the Auxiliary output or Lamp. To use the function, target beam(s) must be designated.
	Designated beam output information	Information on the beam state of user-designated beam(s) to be signaled to the Auxiliary output or Lamp. To signal the information, the Designated beam output information must be assigned to an output destination.
	Dynamic muting	Function to configure a new muting zone after muting is enabled based on a result measuring a workpiece height for a certain period of time.
E	Effective aperture angle (EAA)	Range of angles in which the F3SG-SR can operate.
	Excess power-on time information	Information to be signaled to the Auxiliary output or Lamp when the power-on time exceeds the power-on time threshold value. To signal the information, the Power-On Time information must be assigned to an output destination.
	Exit-only muting delay time	Time difference from when the signal of Muting input A or B is turned OFF until the Muting state is cancelled.
	Exit-only muting mode	Muting mode to be used for such an application where objects move from the inside to the outside of the hazardous zone.
	External device monitoring function (EDM)	Function to monitor the operation of an N.C. contacts of external relays (or contactors) that control the hazardous zone of a machine, for any malfunctions such as welding.
	External test	Function that stops emission at a specified time to check that the Safety outputs are being properly turned OFF.
F	Fixed blanking	Function to disable part of the detection zone of the F3SG-SR and keep the Safety outputs in the ON state even if an object blocks the disabled detection zone.
	Fixed blanking monitoring function	Function to bring the F3SG-SR in the LOCKOUT state when part of the Fixed Blanking zone is unblocked.
	Floating blanking	Function to disable a specified number of beams in the detection zone of the F3SG-SR, and keep the Safety outputs in the ON state even if an object smaller than the dimension of the specified number of beams blocks the F3SG-SR.
	Floating blanking monitoring function	Function to bring the F3SG-SR in the LOCKOUT state if the number of blocked beams is smaller than specified.
I	Interlock	Information to be signaled to the Auxiliary output or Lamp when the F3SG-SR is in the Interlock is state. To signal the information, the Interlock information must be assigned to an output destination.
	Interlock Information	Provides output through auxiliary output if interlock input is ON. Note that interlock information must be assigned to the destination.

	Term	Description
	Interlock reset	Cancels the INTERLOCK state.
	Inverted signal output mode	In this mode, the logic of the Auxiliary output signal is reversed.
L	Light level diagnosis information	Information to be signaled to the Auxiliary output or Lamp when the Safety output is in the ON state and when the incident light level is from 100% to 170% of the ON-threshold value for 10 seconds or more. To signal the information, the Light Level Diagnosis information must be assigned to an output destination.
	Light level monitoring	Function to read out the light level of incident light or ambient light on the F3SG-SR.
	Load switching frequency	Function to display the number of operations of a load to be connected to the F3SG-SR. The number is counted from when the number was last reset until the present time.
	Lockout	Function to keep the Safety outputs in the OFF state when an error is detected by the F3SG-SR.
	Lockout information	Information to be signaled to the Auxiliary output or Lamp when an error or lockout occurs. To signal the information, the Lockout information must be assigned to an output destination.
	Lower beam(s)	Beams located toward the Power Cable of the F3SG-SR.
M	Maintenance information	Function to read the maintenance information of the F3SG-SR and view it on a PC screen, with the Configuration Tool.
	Manual reset mode	Function to enable the Start Interlock and Restart Interlock. The Safety outputs are turned ON by applying a reset signal when there is no object in the detection zone.
	Maximum allowable muting signal interruption	Maximum duration of a signal interruption allowed in Muting inputs A and B.
	Muting	Function to temporarily disable the safety function of the F3SG-SR and keep the Safety outputs in the ON state even if the F3SG-SR is blocked.
	Muting end wait time	Time difference from when the F3SG-SR is unblocked until the Muting state is cancelled.
	Muting input time limit value (maximum)	Maximum time difference between Muting inputs A and B.
	Muting input time limit value (minimum)	Minimum time difference between Muting inputs A and B.
	Muting key cap	Connector to be attached to the end cap of an emitter or receiver to use the Muting function.
	Muting sensor	Input device, such as photoelectric sensor or proximity sensor, to give an input signal for notifying the start and end of the Muting function.
	Muting sequence error	An error that occurs when muting signal is not received in the correct order. The Safety outputs keep in the ON state unless the F3SG-SR is blocked.
	Muting time limit	The duration time of the Muting function. The Muting state is cancelled if it continues for longer than this time limit.
N	Number of floating beams	Number of beams to be configured in the Floating Blanking zone, for which the F3SG-SR does not transition to the LOCKOUT state or Machine Stop state (Safety output OFF) even when blocked.
O	Object resolution (Detection capability)	According to IEC 61496-2; For the F3SG-SR, minimum size of an object that can be detected in the protective height. For the F3SG-PG, minimum size of an object that can be detected on the any optical axes.
	Operating range selection	Function to change the operating range by changing the emission light level of the F3SG-SR.
	Operating status monitoring	Function to read out the I/O data and status of functions of the F3SG-SR.
	Output operation mode	Information to be signaled to an output part (Safety output, Auxiliary output).
	Override	Function that forcibly turns the Safety outputs ON when the Muting is not working.
	Override input time limit (maximum)	Input time limit (maximum value) of the special sequence to activate the Override function.
	Override time limit	The duration time of the Override function. The Override state is cancelled if it continues for longer than this time limit.

	Term	Description
P	PELV	Protected Extra Low Voltage. A grounded circuit separated by double insulation or equivalent from hazardous voltage. It does not generate voltage that exceeds ELV under normal conditions and under single-fault conditions. Normally, protection against direct contact is required.
	PNP/NPN Selection	Function to select the safety output type between PNP and NPN.
	Position detection muting mode	Mode that enables the Muting function according to the position of a hazardous source such as a robot arm, using heterogeneous redundant inputs.
	Power-on time	Function to display the period of time when the F3SG-SR is energized, starting from when the power-on time was last reset until the present time.
	Power-on time reset	Function to reset the power-on time of the F3SG-SR to 0. In the case of cascade connection, the power-on time can be reset for each cascaded segment of the F3SG-SR.
	Power-on time threshold value	When the power-on time exceeds this value, an output is signaled to the Auxiliary output or Lamp. To signal the information, the Power-On Time information must be assigned to an output destination.
	Pre-Reset	One of the INTERLOCK reset functions. Interlock state can be released only in the sequence that the operator operates the Pre-reset switch installed in the hazardous zone and leave the hazardous zone, and then operates the Reset switch outside the hazardous zone.
	Pre-Reset state	The F3SG-SR under this state is allowed to be blocked after the input of the Pre-Reset signal is ensured. When the number of times the F3SG-SR is blocked is set to infinite, the F3SG-SR stays in this state until the Reset input signal is received.
	Primary sensor	Name used for the F3SG-SR to be connected nearest the power supply, when in cascade connection.
R	Reduced resolution	Function to change the size of the object resolution so that an object of the size between 1 and 3 beams has no effect.
	Reset	Function to release the INTERLOCK state or LOCKOUT state.
	Response time adjustment	Function to change the response time so that the Safety outputs can hardly be turned OFF due to accidental interruption by an environmental factor.
	Response time from ON to OFF	Period of time from when the F3SG-SR is blocked until the Safety outputs are turned from ON to OFF.
	Restart interlock	Function to turn the Safety outputs to the OFF state when the F3SG-SR is blocked and keep this state until a reset signal is received.
S	Safety output (OSSD)	Output to be turned to the ON state when safety is ensured. This can be used for safety applications.
	Safety output information	Information to be signaled to the Auxiliary output or Lamp when the Safety outputs are in the ON state. To signal the information, the Safety output information must be assigned to an output destination.
	SD Manager 3	Setting software that is used as the Configuration Tool for the F3SG-SR. It allows the user to make settings to or monitor the operation of the F3SG-SR when the F3SG-SR is connected to the PC via the Intelligent Tap or Bluetooth® Communication Unit.
	Secondary sensor	Name used for other segments of F3SG-SR's than the primary sensor, when in cascade connection.
	SELV	Safety Extra Low Voltage. An ungrounded circuit separated by double insulation or equivalent from hazardous voltage. It does not generate voltage that exceeds ELV under normal conditions and under single-fault conditions. If the nominal voltage exceeds 25 VAC or 60 VDC, protection against direct contact is required.
	SETTING recovery	Function to restore the factory settings of the F3SG-SR.
	SETTING state	Status of the F3SG-SR when settings are being performed with the Configuration Tool. In this state, the Safety outputs are in the OFF state.
	Standard muting mode	Muting mode to be used for such an application where a muting sensor is positioned on both sides of the F3SG-SR. The factory default setting is this mode.
	Start interlock	Function to turn the Safety outputs to the OFF state at power-on or recovery from power failure and keep this state until a reset signal is received.

	Term	Description
T	Teach-in	Function to configure target beams of the following functions by blocking the beams. - Fixed Blanking - Floating Blanking
	Troubleshooting support signal	Information to be signaled to the Auxiliary output or Lamp when any one of a Muting Sequence Error, Interference/Vibration Information and Light Level Diagnosis Information signals is in the ON state. To signal the information, the Troubleshooting Support signal must be assigned to an output destination.
U	Upper beam(s)	Beams located toward the terminal of the F3SG-SR.
V	Vs	Power supply voltage value in your usage environment.
W	Warning zone function	Function to configure part of the detection zone, in which the Safety outputs are not affected by the beam state. The blocked state of the Warning zone can be signaled to the Auxiliary output. This function must not be used for safety applications.
	Warning zone information	Information to be signaled to the Auxiliary output or Lamp when the Warning zone is blocked. To signal the information, the Warning Zone information must be assigned to an output destination.

8-4. Revision History

A manual revision code appears as a suffix to the manual number at the bottom of the front and back covers of this manual.

Z405-E1-10



Revision No.

Revision symbol	Revision date	Revisions
01	May 2019	First edition
02	November 2019	Added conditions to ■ <i>Restrictions on cable extension in 1-5. Ratings and Specifications.</i>
03	June 2020	Complete revision associated with addition of the Safety Multi-Light Beam and accessories
04	September 2022	Changed the content of "Terms and Conditions Agreement" Corrected the erroneous description.
05	December 2022	Added ■ <i>Considerations for replacing F3SG-SR/PG with the settings changed of 2-1. Combination of Functions.</i> Added 4-6. <i>SD Manager 3 Application Example.</i> Revision associated with adding accessory.
06	February 2023	Corrected the erroneous description.
07	September, 2023	- Added precaution to <i>Safety Precautions.</i> - Change in quantity of accessories (Instruction sheet, Quick installation manual). - Deleted unnecessary compliance condition table and statements based on revision of GB/T 4584. - Changed Vibration and Shock resistance specifications based on revision of EN 61496-1.
08	November 2024	Added a description regarding the toggle function for the Backup/Restoration operation settings and revise the related sections. Added a description to '4-1-2-1. PC Environment' to accommodate Windows 11 support. Implemented comprehensive corrections and additions throughout the document.
10	June 2026	Changed the mark color for F39-GCNY2 and F39-GCNY3.

OMRON Corporation Industrial Automation Company

Kyoto, JAPAN

Contact : www.ia.omron.com

Regional Headquarters

OMRON EUROPE B.V.

Wegalaan 67-69, 2132 JD Hoofddorp
The Netherlands
Tel: (31) 2356-81-300 Fax: (31) 2356-81-388

OMRON ASIA PACIFIC PTE. LTD.

438B Alexandra Road, #08-01/02 Alexandra
Technopark, Singapore 119968
Tel: (65) 6835-3011 Fax: (65) 6835-3011

OMRON ELECTRONICS LLC

2895 Greenspoint Parkway, Suite 200
Hoffman Estates, IL 60169 U.S.A.
Tel: (1) 847-843-7900 Fax: (1) 847-843-7787

OMRON (CHINA) CO., LTD.

Room 2211, Bank of China Tower,
200 Yin Cheng Zhong Road,
PuDong New Area, Shanghai, 200120, China
Tel: (86) 21-6023-0333 Fax: (86) 21-5037-2388

Authorized Distributor:

©OMRON Corporation 2019-2026 All Rights Reserved.
In the interest of product improvement,
specifications are subject to change without notice.

Cat. No. Z405-E1-10 0626 (0519)